

AUGUST 1, 1957

# electronics

A MCGRAW-HILL PUBLICATION • PRICE ONE DOLLAR

NEW TUBE BOOSTS  
RADAR'S RANGE

BUTLER  
OSC



See pg 240!

VIDEO  
RECORDING...page 138

Magnetic Computer .....page 156

Measuring Transistor Parameters .....274





# DO-TS

## Deci-Ouncer Transformers

### REVOLUTIONARY TRANSISTOR TRANSFORMERS

of unequalled power handling capacity and reliability

Hermetically Sealed to MIL-T-27A Specs.

#### TYPICAL DO-T PERFORMANCE CURVES

Power curves based on setting output power at 1 KC, then maintaining same input level over frequency range.

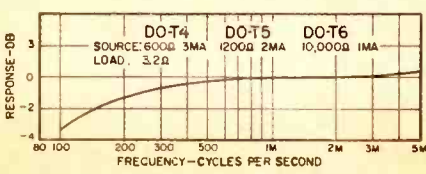
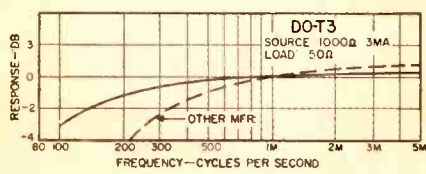
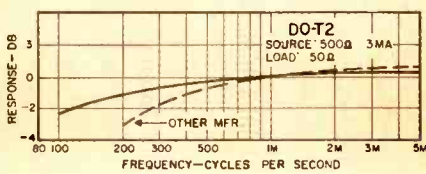
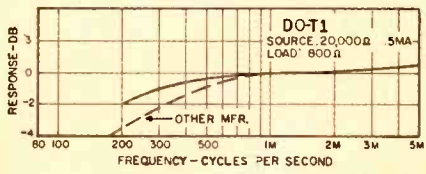
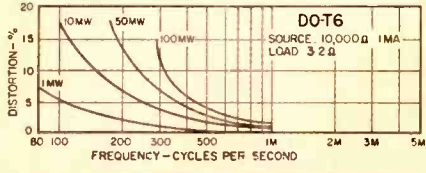
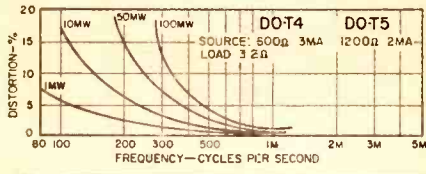
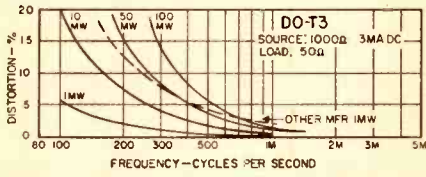
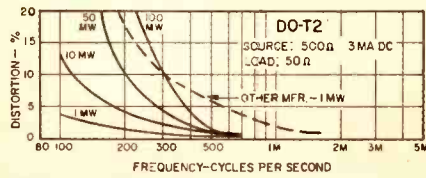
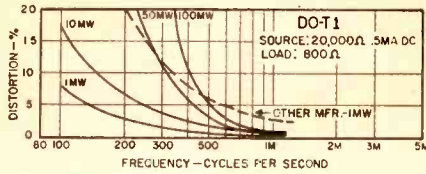

Conventional miniaturized transistor transformers have inherently poor electrical characteristics, perform with insufficient reliability and are woefully inadequate for many applications. The radical design of the new UTC DO-T transistor transformers\*\* provides unprecedented power handling capacity and reliability, coupled with extremely small size. Twenty-five stock types cover virtually every transistor application\*. Special types can be made to order.

High Power Rating . . . up to 100 times greater.

Excellent Response . . . twice as good at low end.

Low Distortion . . . reduced 80%.

High Efficiency . . . up to 30% better.

Moisture Proof . . . hermetically sealed to MIL-T-27A.

Rugged . . . completely cased.

Anchored Leads . . . will withstand 10 pound pull test.

Printed Circuit Use . . . (solder melting) plastic insulated leads.

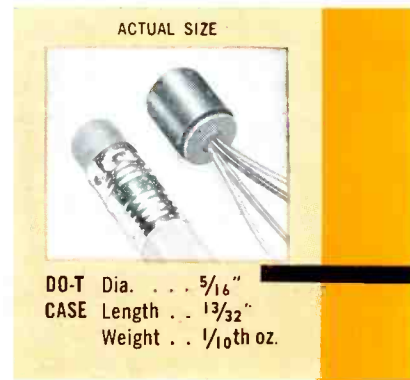

Type No.	MIL Type	Application	Pri. Imp.	D.C. Ma.± in Pri.	Sec. Imp.	Pri. Res.	Level Mw.
DO-T1	TF4RX13YY	Interstage	20,000 30,000	.5 .5	800 1200	850	50
DO-T2	TF4RX17YY	Output	500 600	3 3	50 60	60	100
DO-T3	TF4RX13YY	Output	1000 1200	3 3	50 60	115	100
DO-T4	TF4RX17YY	Output	600	3	3.2	60	100
DO-T5	TF4RX13YY	Output	1200	2	3.2	115	100
DO-T6	TF4RX13YY	Output	10,000	1	3.2	1000	100
DO-T7	TF4RX16YY	Input	200,000	0	1000	8500	25
DO-T8	TF4RX20YY	Reactor 3.5 Hys. @ 2 Ma. DC				630	
DO-T9	TF4RX13YY	Output or driver	10,000 12,500	1 1	500 CT 600 CT	800	100
DO-T10	TF4RX13YY	Driver	10,000 12,500	1 1	1200 CT 1500 CT	800	100
DO-T11	TF4RX13YY	Driver	10,000 12,000	1 1	2000 CT 2500 CT	800	100
DO-T12	TF4RX17YY	Single or PP output	150 CT 200 CT	10 10	12 16	11	500
DO-T13	TF4RX17YY	Single or PP output	300 CT 400 CT	7 7	12 16	20	500
DO-T14	TF4RX17YY	Single or PP output	600 CT 800 CT	5 5	12 16	43	500
DO-T15	TF4RX17YY	Single or PP output	800 CT 1070 CT	4 4	12 16	51	500
DO-T16	TF4RX13YY	Single or PP output	1000 CT 1330 CT	3.5 3.5	12 16	71	500
DO-T17	TF4RX13YY	Single or PP output	1500 CT 2000 CT	3 3	12 16	108	500
DO-T18	TF4RX13YY	Single or PP output	7500 CT 10,000 CT	1 1	12 16	505	200
DO-T19	TF4RX17YY	Output to line	300 CT	7	600	19	500
DO-T20	TF4RX17YY	Output or matching to line	500 CT	5.5	600	31	500
DO-T21	TF4RX17YY	Output to line	900 CT	4	600	53	500
DO-T22	TF4RX13YY	Output to line	1500 CT	3	600	86	500
DO-T23	TF4RX13YY	Interstage	20,000 CT 30,000 CT	.5 .5	800 CT 1200 CT	850	100
DO-T24	TF4RX16YY	Input (usable for chopper service)	200,000 CT	0	1000 CT	8500	25
DO-T25	TF4RX13YY	Interstage	10,000 CT 12,000 CT	1 1	1500 CT 1800 CT	800	100

±DCMA shown is for single ended useage (under 5% distortion—100MW—1KC) . . . for push pull, DCMA can be any balanced value taken by .5W transistors (under 5% distortion—500MW—1KC)

## UNITED TRANSFORMER CORP.

150 Varick Street, New York 13, N. Y.

PACIFIC MFG. DIVISION: 4008 W. JEFFERSON BLVD., LOS ANGELES 16, CALIF.

EXPORT DIVISION: 13 EAST 40th STREET, NEW YORK 16, N. Y.

CABLES: "ARLAB"

\*DO-T units have been designed for transistor application only . . . not for vacuum tube service. \*\*Pats. Pending



## A MCGRAW-HILL PUBLICATION

H. W. MATEER, *Publisher*

W. W. MacDONALD, *Editor*

*Managing Editors*  
VIN ZELUFF  
JOHN M. CARROLL

*Feature Editor*  
JOHN MARKUS

*Associate Editors*  
JOHN M. KINN, Jr.  
FRANK LEARY  
MICHAEL F. TOMAINO  
HOWARD K. JANIS  
SYLVESTER P. CARTER  
DAVID A. FINDLAY  
HAIG A. MANOOGIAN

*Assistant Editors*  
WILLIAM P. O'BRIEN  
GEORGE SIDERIS  
LAWRENCE KAMARCK  
EDWARD DeJONGH  
JOHN F. MASON

*Pacific Coast Editor (Los Angeles)*  
HAROLD C. HOOD

*Midwestern Editor (Chicago)*  
HAROLD HARRIS

*New England Editor (Boston)*  
ROLAND J. CHAREST

HARRY PHILLIPS, *Art Director*  
ROY THOMPSEN  
BARBARA ELLWOOD  
JOHN C. WRIGHT, Jr., *Production*  
JEAN L. MATIN

*Editorial Assistants*  
GLORIA J. FILIPPONE  
ARLENE SCHILP  
BERNICE DUFFY  
BARBARA HEARST  
NOREEN HENNESSY  
PHYLIS A. CRONIN  
BARBARA M. SHAW

**JAMES GIRDWOOD**, *Adv. Sales Mgr.*  
R. S. QUINT, *Assistant Adv. Sales Mgr. and  
Buyers' Guide Mgr.*  
FREDERIC STEWART, *Promotion Mgr.*  
FRANK H. WARD, *Business Mgr.*  
G. E. POMEROY, *Classified Mgr.*  
JEAN W. HEIGES, *Research*  
WALLACE B. BLOOD, *Market Consultant*

*New York*  
DONALD H. MILLER  
HENRY M. SHAW  
MARTIN J. GALLAY

*Boston*  
WM. S. HODGKINSON

*Philadelphia*  
JAMES T. HAUPTLI

*Chicago*  
BRUCE WINNER  
WALTER M. LUCE

*Cleveland*  
WARREN H. GARDNER

*San Francisco*  
T. H. CARMODY  
R. C. ALCORN

*Los Angeles*  
CARL W. DYSINGER  
RUSSELL H. ANTLES

*Atlanta*  
M. MILLER

*Dallas*  
GORDON L. JONES

*London*  
HERBERT LAGLER

KEITH HENNY, *Consultant*

**BOOSTS RADAR'S RANGE**—Cross-field Platinotron developed by Raytheon can be used as high-power broadband microwave amplifier for scanning without moving reflector, for boosting power of existing sets or serving as frequency-stabilized oscillator (see p 164)..... **COVER**

SHOPTALK ..... **2**

FIGURES OF THE MONTH ..... **6**

INDUSTRY REPORT ..... **7**

Passive Radar Technique.....	7	Bank Teller-Vision.....	20
Sign Flashes Speed Warning.....	8	Hawaii Cable Ready Soon.....	20
New England Outlook Bright.....	8	FCC Actions.....	22
Spacistor Looks Promising.....	10	Mobile Patrols Turnpikes.....	22
Hotels Are Big Market.....	12	Solid State Gains Amplifier.....	24
Business Briefs.....	12	Computer Design Checked.....	26
Microwaves Freeze-Dry Foods.....	14	World Radios Surveyed.....	26
Navy Unveils Talos Missile.....	14	TV Guards Turnstiles.....	26
VHF Controls Power Plants.....	14	Financial Roundup.....	28
Computers Get Smarter.....	16	Transistor Gaseous-Process.....	28
Military Electronics.....	16	Meetings Ahead.....	28
Rack Cuts Test Time.....	20	Industry Shorts.....	28

CROSSTALK ..... **137**

## FEATURES

<b>Video Tape Recorder Uses Revolving Heads</b> .....	<b>138</b>
By Ross H. Snyder	
<b>Pulsed Light Tests Minority-Carrier Life</b> .....	<b>145</b>
By H. L. Armstrong	
<b>Rural Carrier System Uses Transistors</b> .....	<b>146</b>
By B. R. Stachiewicz	
<b>Core Tester Simplifies Amplifier Design</b> .....	<b>150</b>
By R. W. Roberts and C. C. Horstman	
<b>Video Scanner Matches Photo Patterns</b> .....	<b>154</b>
By E. J. Oelbermann	
<b>Magnetic Computer Has High Speed</b> .....	<b>156</b>
B. T. H. Bonn	
<b>Transistor Amplifier for Medical Recording</b> .....	<b>161</b>
By D. W. R. McKinley and R. S. Richards	
<b>Platinotron Increases Search Radar Range</b> .....	<b>164</b>
By William C. Brown	
<b>Transistorized Lab Relay</b> .....	<b>169</b>
By Harry A. Gill	

CONTINUED ON NEXT PAGE



Sync Generator for Dot-Interlace TV.....	170
By Francis T. Thompson	
Measuring Parameters of Junction Transistors.....	174
By Roy W. Hendrick, Jr.	
Three Oscillator Designs Standardize Circuitry.....	177
By H. E. Gruen	
Motion Minimizes Image Orthicon Burn-in.....	180
By John T. Wilner	
Automatic Data Plotter for F-M/F-M Telemetry.....	182
By H. B. Riblet	
Amplifier Selectivity Curves (Reference Sheet).....	188
By Ronald L. Quandt and Jack Sanders	

## ELECTRONS AT WORK..... 192

Radio Link Uses Meteor Trails.....	192	Low-Mu Triodes Control Power.....	204
Magnetic-Optical Recording.....	192	By John Degelman	
Reflex Transistor Radio.....	192	Electro-optical Amplifier.....	210
Spot Wobble Cuts TV Lines.....	194	Transistor Beta Tester.....	212
Magnetic Core Circuits.....	194	By John D. Harmer	
By A. L. Reedman		Pulse Attenuators for CRO.....	218
Silicon Logarithmic Elements.....	196	By H. Bruce McFarlane	
By Y. Golahny		Ultrasonic Surgery.....	228
Galactic Noise in TV Receivers.....	198	Grounded Grid Operation.....	230
Preamplifier for Pickups.....	200	By Frank Agresti	
By William Newitt		Large Shielded Enclosure.....	236
Simple Sweep Generator.....	202	By Richard J. Costello and Bryce D. McMichael	
By H. L. Armstrong			

## PRODUCTION TECHNIQUES..... 240

Juke-Box Transistor Tester.....	240	Turntable Speeds Assembly.....	246
Wrapping Hurts Soldered Joints.....	240	Solder Wave for Printed Circuits.....	248
Design of the Month: Noise Tube.....	242	Coated-Filler Resin for Potting.....	258
Conductive Wax for Connections.....	244	By R. Herr and J. S. Casement	
Magnetic Rings Hold Parts.....	246	Rat Trap Holds Plugs.....	268

## NEW PRODUCTS..... 270

## LITERATURE..... 342

## PLANTS AND PEOPLE..... 350

## NEW BOOKS..... 373

## THUMBNAIL REVIEWS..... 380

## BACKTALK..... 386

## INDEX TO ADVERTISERS..... 425

# SHOP

### ► ULTIMATE MANUSCRIPT . . .

The editors are constantly trying to determine which articles are the most popular with the readers of **ELECTRONICS**. This is done by mail surveys and through personal conversations with engineers in the field.

Certain subjects are always popular, and we have noticed in recent years that any article with the word "transistor" in the title has a high readership.

In looking for the impossible, an article that would attract every reader, one of the editors has suggested a title that we believe is sure to get 100-percent readership.

The title is "Transistorized Hi-Fi Audio Amplifier Receives, Controls and Transmits Signals for Automatic Production of Printed Circuits for Guided Missiles."

Anybody want to take a crack at writing it?

► **HIGH STANDARDS** . . . We have been sincerely flattered. Recently, one of the largest communication equipment manufacturers, going through the throes of organizing an internal electronics engineering publication, called on us for help.

Staffers of the new venture needed to codify various aspects of style and handling of manuscripts. After studying the problem, and numerous publications, they decided to be guided by our methods. We were called to furnish material and reference sheets suitable for the purpose.

# electronics

AUGUST 1, 1957 Vol. 30, No. 8



Member ABC and ABP



# TALK

We await with interest the first issue.

► **CONSTANT READERS** . . . Some time ago we wrote about a graduate class in missile guidance principles using **ELECTRONICS** articles as reference reading.

We have since learned from A. E. Nashman of the Guided Missile Laboratory of Federal Telephone Labs (ITT) and coordinator of the course that all members of the class are working engineers in electronics with two to nine years experience and 50-percent of them read our magazine regularly.

► **HO-HUM** . . . Some of the news periodicals recently carried a short story about a certain tape recorder, said to be the "world's smallest." Announced that it would be put on the market soon.

Surprised us a bit, since the technical details and complete circuit were published a year ago in **ELECTRONICS**, July 1956.

► **THE LEAD FEATURE** . . . It all started when Ampex first announced its video tape recorder.

Contacting the company for the technical story, associate editor Haig Manoogian was told by the author, Ross Snyder;

"While the demand for technical articles on the new VR-1000 Videotape Recorder would easily exhaust the ability of every engineer we have to write, even if we were to put them to work at nothing else for



**ELECTRONICS** congratulates Ampex Corp. for the Emmy Award the company received for its video tape recorder development from the Academy of Television Arts and Sciences. The two-inch tape travels at a speed of 15 inches per second while the recording heads revolve

months to come, we certainly consider **ELECTRONICS** of such importance to the entire electronic engineering profession that we feel an obligation to provide you with an article which is satisfactory to you and to your readership."

We can't think of a nicer way for an author to accept a bid. We particularly appreciate his comment on our magazine, because we found out he has been reading it since he was 14 years old.

Follow-up in the normal business of publishing and handling of details involved sixteen letters, three telegrams, four coast-to-coast phone

calls, two to Chicago and a couple of lunches.

The article starts on page 138 of this issue. We bylined it with Ross' name to give it a specific reference source, although he feels the credit belongs to many.

"Because I have drawn so freely on the laboratory notes of our Video Laboratory Staff in writing the article, the article really should be published under the byline of the Staff, rather than by me. While I will have assembled the words, it is certainly the combined effort of the staff which produced the information, and all should be credited."

Published three times a month, with an additional issue in June, by McGraw-Hill Publishing Company, Inc., James H. McGraw (1860-1948), Founder, Executive, Editorial, Circulation and Advertising Offices: McGraw-Hill Building, 330 W. 42 St., New York 36, N. Y. Longacre 4-3000. Publication Office 99-129 North Broadway, Albany 1, N. Y. See panel below for directions regarding subscription or change of address. Donald C. McGraw, President; L. Keith Goodrich, Vice President and Treasurer; John J. Cooke, Secretary; Nelson Bond, Executive Vice President, Publications Division; Ralph B. Smith, Vice President and Editorial Director; Joseph H. Allen, Vice President and Director of Advertising Sales; A. R. Venezian, Vice President and Circulation Coordinator.

Single copies \$1.00 for Technical Edition and 50¢ for Business Edition in United States and possessions, and Canada; \$2.00 and \$1.00 for all other foreign countries. Buyers' Guide \$3.00. Subscription rates—United States and possessions, \$8.00 a year; \$9.00 for two years. Canada, \$10.00 a year, \$16 for two years. All other countries \$20.00 a year, \$30.00 for two years. Three-year rates accepted on renewals only, are double the one-year rate. Entered as second-class matter August 29, 1938, at the Post Office at Albany, N. Y., under act of Mar. 3, 1879. Printed in U.S.A. Copyright 1957 by McGraw-Hill Publishing Co., Inc.—All Rights Reserved. Title registered in U. S. Patent Office. BRANCH OFFICES: 520 North Michigan Avenue, Chicago 11; 68 Post Street,

San Francisco 4; McGraw-Hill House, London E. C. 4; National Press Bldg., Washington, D. C. 4; Architects Bldg. 17th & Sanson Sts., Philadelphia 3; 1111 Henry W. Oliver Bldg., Pittsburgh 22; 1510 Hanna Bldg., Cleveland 15; 856 Penobscot Bldg., Detroit 26; 3615 Olive St., St. Louis 8; 350 Park Square Bldg., Boston 16; 1321 Rhodes Haverly Bldg., Atlanta 3; 1125 West Sixth St., Los Angeles 17. **ELECTRONICS** is indexed regularly in The Engineering Index.

Subscriptions: Address correspondence to Subscription Manager, Electronics, 330 W. 42nd St., New York 36, N. Y. Allow one month for changes of address, stating old as well as new address. Subscriptions are solicited only from persons engaged in theory, research, design, production, maintenance and use of electronic and industrial control components, parts and products. Position and company connection must be indicated on subscription orders.

Postmaster: please send form 3579 to Electronics, 330 W. 42 St., New York 36, N. Y.



# transistor power supplies

## NEWLY DESIGNED FOR TRANSISTOR VOLTAGES

- 3 RANGES—FINE RESOLUTION • TUBELESS
- LOW COST • CONTINUOUSLY VARIABLE

These new T-Nobatrons are the perfect solution to the problem of providing well-regulated voltages for the development and testing of transistor circuits. They provide stable DC output voltages in three ranges, with fine resolution. Excellent transient response for line and load pulses. Simple tubeless construction means greater reliability, lower cost. Also ideal for many other applications in these voltage ranges, such as relay testing and computer circuitry development.

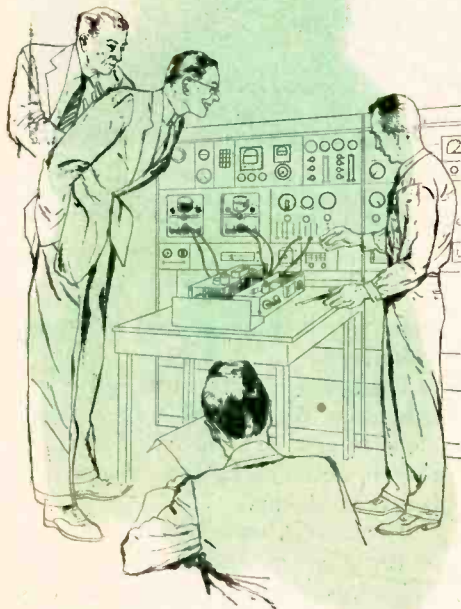

### ELECTRICAL CHARACTERISTICS

	Model T50-1.5	T60-5	T120-2.5
AC Input (60 ~, 1 $\phi$ )	95-130	95-130	95-130
DC Output Voltage (three ranges)	0-10 0-25 0-50	0-10 0-25 0-60	0-25 0-50 0-120
Output Current (amps.)	0-1.5	0-5	0-2.5
Regulation, line: 105-125 V	$\pm 1\%$	$\pm 0.5\%$	$\pm 0.5\%$
For wider input	$\pm 2\%$	$\pm 1.0\%$	$\pm 1\%$
Internal Resistance, typical (ohms)			
low-voltage range	1.2	0.35	1.3
middle range	2.1	0.55	2.0
high range	4.5	1.0	4.0
Ripple (mv)	50 max.	50 max.	50 max.
Time Constant (line)	0.08 sec.	0.08 sec.	0.08 sec.
(load)	0.15 sec.	0.15 sec.	0.15 sec.

### • DUAL RACK INSTALLATION

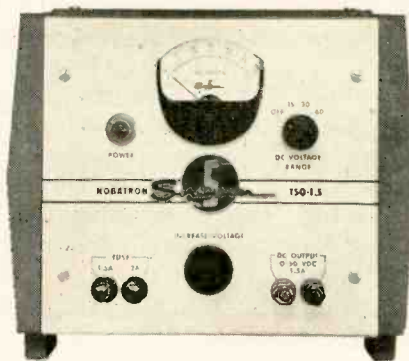

MODEL T50-1.5



See us at  
WESCON  
Booths  
1520-1521

SORENSEN & COMPANY, INC.



SO. NORWALK • CONN.

In Europe, contact Sorensen-Ardag, Eichstrasse 29, Zurich, Switzerland, for all products including 50 cycle, 220 volt equipment.



*Used throughout  
the U.S.A. -*

*(AND THE REST OF THE WORLD)*

**FOR ACCURATE MEASUREMENT OF L, C & R**

**UNIVERSAL BRIDGE Type 868/1**

Inductance from 1  $\mu$ H to 100 H, Capacitance from 1  $\mu$ F to 100  $\mu$ F, and Resistance from 0.1  $\Omega$  to 10 M $\Omega$ . Single direct-reading LCR dial — no multiplying factors involved. Continuously variable a.c. bridge voltage and automatic detector sensitivity control.

**L**  
at 1 or  
10 kc



**C**  
at 1 or  
10 kc

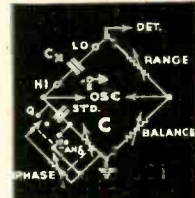

**R**  
at d.c.



**MARCONI  
INSTRUMENTS**

*Marconi-since 1897*

44 NEW STREET · NEW YORK 4

CANADIAN MARCONI COMPANY,  
6035, COTE DE LIESSE,  
MONTREAL 9, CANADA.

HEAD OFFICE: MARCONI INSTRUMENTS LTD · ST. ALBANS · HERTS · ENGLAND



## FIGURES OF THE MONTH

	Latest Month	Previous Month	Year Ago		Latest Month	Previous Month	Year Ago
<b>RECEIVER PRODUCTION</b>				<b>BROADCAST STATIONS</b>			
(Source: RETMA)	May '57	April '57	May '56	(Source: FCC)	April '57	Mar. '57	April '56
Television sets, total	342,386	361,246	467,913	TV stations on air	515	515	489
With UHF	41,596	42,374	58,116	TV stations CPs—not on air	126	126	114
Color sets	nr	nr	nr	TV stations—new requests	72	60	29
Radio sets, total	1,023,771	1,115,813	1,060,165	A-M stations on air	3,049	3,040	2,872
Auto sets	396,151	380,452	282,611	A-M stations CPs—not on air	154	145	118
				A-M stations—new requests	306	308	275
				F-M stations on air	529	526	534
				F-M stations CPs—not on air	22	23	13
				F-M stations—new requests	22	17	6
<b>RECEIVER SALES</b>				<b>COMMUNICATION AUTHORIZATIONS</b>			
(Source: RETMA)	May '57	April '57	May '56	(Source: FCC)	Mar. '57	Feb. '57	Mar. '56
Television sets, units	399,757	337,965	392,080	Aeronautical	50,940	50,859	45,488
Radio sets (except auto)	547,480	543,092	566,357	Marine	61,818	61,246	55,175
				Police, fire, etc.	22,625	22,500	20,216
				Industrial	34,316	33,879	28,454
				Land transportation	9,505	9,484	8,849
				Amateur	159,896	158,232	146,699
				Citizens radio	24,782	23,888	16,262
				Disaster	343	343	327
				Experimental	765	735	666
				Common carrier	2,696	2,666	2,185
<b>RECEIVING TUBE SALES</b>				<b>EMPLOYMENT AND PAYROLLS</b>			
(Source: RETMA)	May '57	April '57	May '56	(Source: Bur. Labor Statistics)	April '57	March '57	April '56
Receiv. tubes, total units	32,836,000	27,970,000	33,015,000	Prod. workers, comm. equip.	380,600-p	386,500-r	379,300
Receiv. tubes, value	\$28,955,000	\$25,384,000	\$27,145,000	Av. wkly. earnings, comm.	\$79.19 -p	79.59 -r	75.33
Picture tubes, total units	758,328	629,838	906,737	Av. wkly. earnings, radio	\$76.61 -p	76.80 -r	72.00
Picture tubes, value	\$14,031,519	\$11,394,043	\$16,123,625	Av. wkly. hours, comm.	40.2 -p	40.4 -r	40.5
				Av. wkly. hours, radio	39.9 -p	40.0	40.0
<b>INDUSTRIAL TUBE SALES</b>				<b>SEMICONDUCTOR SALES ESTIMATES</b>			
(Source: NEMA)	Quarterly Figures						
	Latest Quarter	Previous Quarter	Year Ago				
	1st '57	4th '56	1st '56				
Vacuum	\$11,224,707	\$12,408,371	\$8,754,054				
Gas or vapor	\$3,332,357	\$3,223,612	\$3,394,059				
Magnetrons and velocity modulation tubes	\$15,359,108	\$15,890,681	\$15,136,522				
Gaps and T/R boxes	\$1,409,463	\$1,242,745	\$1,455,558				
<b>MILITARY PROCUREMENT</b>							
(Source: Defense Dept.)	1st '57	4th '56	1st '56				
Army	\$69,381,000	\$56,185,000	\$40,490,000				
Navy	\$21,426,000	\$34,210,000	\$28,700,000				
Air Force	\$159,829,000	\$145,962,000	\$124,828,000				
Total—Electronics	\$250,636,000	\$236,357,000	\$194,018,000				
				<b>STOCK PRICE AVERAGES</b>			
				(Source: Standard and Poor's)	May '57	April '57	May '56
				Radio-tv & electronics	51.69	50.48	60.43
				Radio broadcasters	69.18	68.04	70.87
				p—provisional	r—revised	nr—not reported	

## FIGURES OF THE YEAR

	TOTALS FOR THE FIRST FIVE MONTHS			1956 Total
	1957	1956	Percent Change	
Television set production	2,178,361	2,862,177	-23.9	7,357,029
Radio set production	6,098,951	5,585,390	+ 9.2	13,981,800
Television set sales	2,420,633	2,428,888	- .3	6,804,756
Radio set sales (except auto)	2,909,548	2,551,272	+14.0	8,332,077
Receiving tube sales	185,847,000	188,619,000	- 1.5	464,186,000
Cathode-ray tube sales	3,710,646	4,376,142	-15.2	10,987,021



# INDUSTRY REPORT

electronics—August 1 • 1957

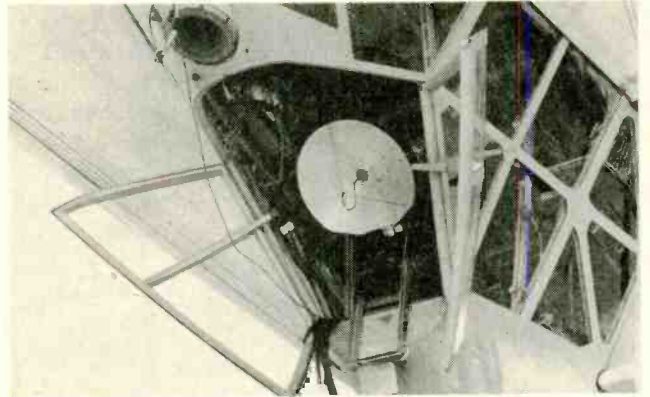
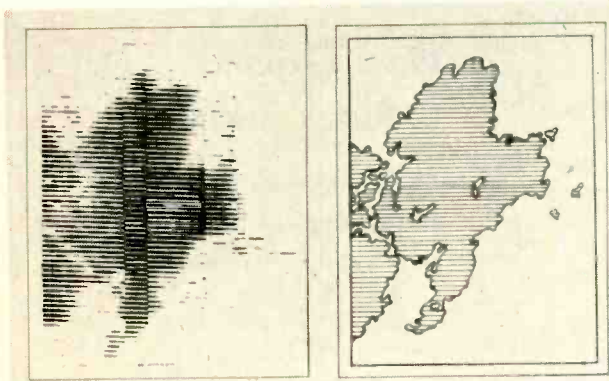

**RADIOMETRIC** map of Cape Ann, compared with chart reproduction, (left) produced by experimental passive radar system installed in Navy blimp (right) shows what results when . . .

## Passive Radar Technique Uses Microwaves

Operating technique similar to infrared except system detects microwave radiation

CHANCE downward deflection of an antenna, during World War II measurements of atmospheric absorption of K-band energy by a group at MIT's Radiation Laboratories, resulted in the discovery that microwave energy is radiated from the ground and its intensity varies with the type of object.

Subsequent work by a group at Air Force Cambridge Research Center propagation laboratory has led to the development of a detection system using this phenomenon. The system is based on radiometric principles and is called passive radar.

► **How It Works**—Microwave energy that the passive radar antenna receives is a form of noise which must be distinguished from the noise generated in the receiver it-

self. Basically, this is done by alternately blocking and passing the noise signal to the receiver, through use of a chopping wheel in the input waveguide section, amplifying this signal and phase detecting it to null out the effects of the receiver's internally generated noise.

The resultant signal is integrated in a low-pass filter and applied to a strip recorder to drive the pen. This produces an apparent temperature profile of the objects scanned. Frequencies used in technique were 1.25, 3.2 and 8 cm.

► **Theory**—Although the bulk of energy radiated from earthly objects is in the infrared range, every object whose temperature exceeds absolute zero radiates electromagnetic energy throughout the spectrum. The system, a form of microwave radiometry, uses the black body (perfect radiator—perfect absorber) as a reference.

Frequently, a non-black body temperature is given in terms of an equivalent black body temperature. The equivalent temperature is the product of its absolute temperature and its emissivity which is defined as the ratio of the object's radiation to that of an equivalent black body at the same temperature. Thus a body of water whose absolute temperature is 400 K and whose microwave emissivity is 55 percent will emit radiation equivalent to a black body at 220 K.

A passive radar antenna aimed at the water would not only pick up this radiation but would also see energy reflected from sky radiation.

► **Detectability** — Two objects at the same temperature can be discriminated owing to their different emissivities. For example, water has an emissivity of 45 percent and a reflectivity of 55 percent while land runs approximately 90 and 10

percent respectively.

Thus the energy radiated from the ground is about 70 percent greater than that radiated from the water providing more than a sufficient difference to discriminate between the two.

Other factors affecting discrimination are: angle between antenna beam and objects, antenna beam-width and polarization and the receiver's minimum detectable signal level, which is primarily a function of bandwidth in this application.

► **Comparison** — Present passive radar techniques do not yield results that are comparable to infrared or radar. One advantage, however, is that the system does not radiate, thus matching infrared in its security from detection. Further advantages accrue through its

being lighter, smaller and less complex than active radars.

Passive radar resolution is inherently inferior to infrared owing to its lower operating frequency, however its ability to discriminate between different types of targets can be as good or better than either infrared or active radar.

► **Future** — Early experimental equipment used at the Air Force Cambridge Research Center employed conventional radar receiver components. Use of traveling-wave tubes and new techniques to obtain wideband receiver operation should provide a significant improvement in response time and ability to discriminate to the point where such systems might compete with present infrared and radar surveillance systems.

Mans race in France were reported hourly from an IBM computing center set up at the auto pits.

Use of the computer was in calculating performance index, which varies with size and motor of the car as well as speed.

Computer input was punched cards containing details on the cars and timekeeper reports. Output was an hourly stencil for officials and press.

## New England Outlook Bright

Electronics industry sparks Yankee tradition of developing new products

PLANT SPACE of New England's electronics industry increased about 23 percent between January 1953 and October 1955 and the section has ambitious plans for future expansion. If the plans are carried out, electronics firms will spend \$67 million for new plant and equipment, expand manufacturing space by 18 per cent and add about 8,000 workers in the next few years.

► **Research** and development activities are playing an important role in developing new products and jobs in New England's electronics industry. The number of companies having research and development programs expanded by over 50 per cent between 1950 and 1954, and annual expenditures for such activities advanced from \$26 million to \$42.6 million. Over half the employees of New England electronics concerns in 1955 were working on products developed by research within the past five years.

The Federal Reserve Bank of Boston conducted its first study of New England's electronics industry in 1953. That study disclosed that employment in the industry increased rapidly between January 1951 and January 1953 and depended heavily on government contracts. To ascertain current plans of electronics manufacturers and

(Continued on page 10)



NEON sign, hooked to radar timer, lights up, driver slows down when . . .

## Sign Flashes Speed Warning

Radar here, computer in France mark auto speed

ELECTRONICS keeps popping up in the automotive world. Two recent reports involve adaptations of old standbys, computer and radar, in speed checking.

► **Speed warning**—A radar timer was hooked into a neon sign by Motor Vehicle Research, Inc., of

New Hampshire. The sign says "Slow Down You Are Speeding" when a passing motorist exceeds a set limit.

The only one in use is set up in front of the Portsmouth, N. H., Air Force Base. Officials report the motorist takes his foot off the gas 9 out of 10 times. Houston police are reported interested.

► **Racing**—Standings of the 50 entrants in the classic 24-hour Le





**HIDDEN TREASURE!**

... the engineering skill in every component by Burnell. Burnell files contain thousands of special designs in regular and subminiature filters.



**TOP OF THE LADDER...**

Burnell products incorporate the highest standards of engineering know-how and precision manufacturing in toroids, filters and related networks.

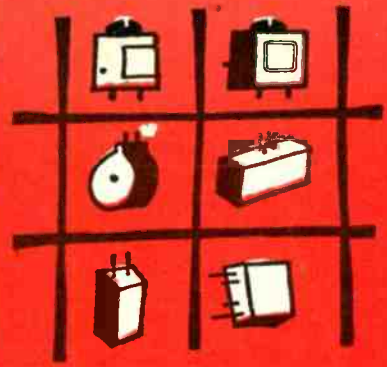

**CROSS-SECTION OF A HUGE SELECTION!**

Burnell has over 8,000 filter designs in stock, including subminiature filters for aircraft and guided missiles, communications filters for receivers, and side-band filters for carriers... in addition to an array of other new, specialized components.

**WHICH AD DO YOU LIKE BEST?**

*they all tell the same basic story*

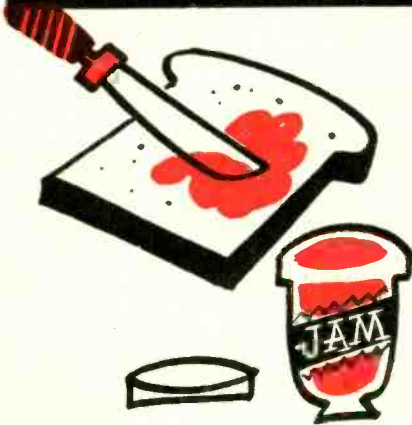

R.J.D.

**WANT JAM ON IT?**

Burnell supplies the **extras** in service, courtesy and sheer engineering value. Your inquiries on toroids, filters and related networks will be handled promptly.



**HOW ABOUT SOME ICING?**

Burnell provides the "top layer" that makes all the difference. Your toroid and filter problems are solved by the most advanced engineering in the field—by Burnell.



**LIKE THE GRAVY TOO?**

Burnell success depends on meeting your exact needs. If the toroidal component you require is not already on our files, we will make it to your exact specifications.



**BEFORE YOUR WIRES GET CROSSED...**

... consult Burnell about your networks problems. Or write for technical information and catalog, without cost or obligation, with details on our toroidal components in regular down to subminiature sizes.



**CREAM COSTS NO EXTRA**

Depend on Burnell for toroids, filters and related networks whether you require standard components, or special, custom-designed equipment.

*Burnell & Co., Inc.*



Dept E87  
10 PELHAM PARKWAY,  
PELHAM MANOR, N. Y.  
TELEPHONE PELHAM 8-5000

PACIFIC DIVISION  
720 MISSION STREET, SOUTH PASADENA, CALIF.  
TELETYPE: PASADENA 7578  
TELEPHONE: RYAN 1-2841

first in toroids, filters and related networks

**"You are cordially invited to visit us at booth number 3101 at the Wescon Show."**



major developments since 1953, a second survey of the electronics industry has been completed.

► **Expansion Plans**—Between January 1953 and October 1955, 115 electronics manufacturers spent \$48.5 million for new plant and equipment in New England. Three-quarters of this amount went for new machinery and equipment. Manufacturing floor space increased from 10,086,771 square feet in January 1953 to 12,431,700 square feet in October 1955.

Capital expenditures of elec-

tronics manufacturers located in Boston area totaled nearly \$28 million during the 33-month period. But only 21 per cent of this was invested in plant facilities. In the rest of New England the ratio was 32 per cent. Smaller manufacturers generally increased their floor space at a more rapid rate than concerns with over 200 employees, although the largest firms accounted for the bulk of new plant construction as well as equipment expenditures.

Ninety-three of the 123 electronics manufacturers surveyed in October 1955 said that they were

planning to expand in New England. Only 13 manufacturers said they were planning to expand their manufacturing facilities outside New England.

► **Encouraging Growth** — Steps suggested most frequently to encourage the growth of the electronics industry in New England involve improved tax treatment, better financing, expanded educational facilities for training engineers and technicians, and industrial development activities to promote New England.

## Spacistor Promises 10,000-mc Amplification

New four-lead semiconductor looks better than tubes and transistors, works up to 500 C

TINY AS the head of a pin is Raytheon's breakthrough in semiconductor amplifiers, operating on a wholly new principle which combines many of the best properties of vacuum tubes and transistors. Utilization of the high field strength at a reverse-biased junction gives acceleration of charge carriers so

their transit time is greatly reduced, leading the way to reliable amplification at frequencies up to 10,000 mc.

► **Temperature Limits** — When made from germanium or silicon, spacistors have the same 200 C temperature limit as present transistors. An important advantage of the new device is its independence of charge-carrier lifetime, making it feasible to use other semiconductor materials. With silicon carbide,

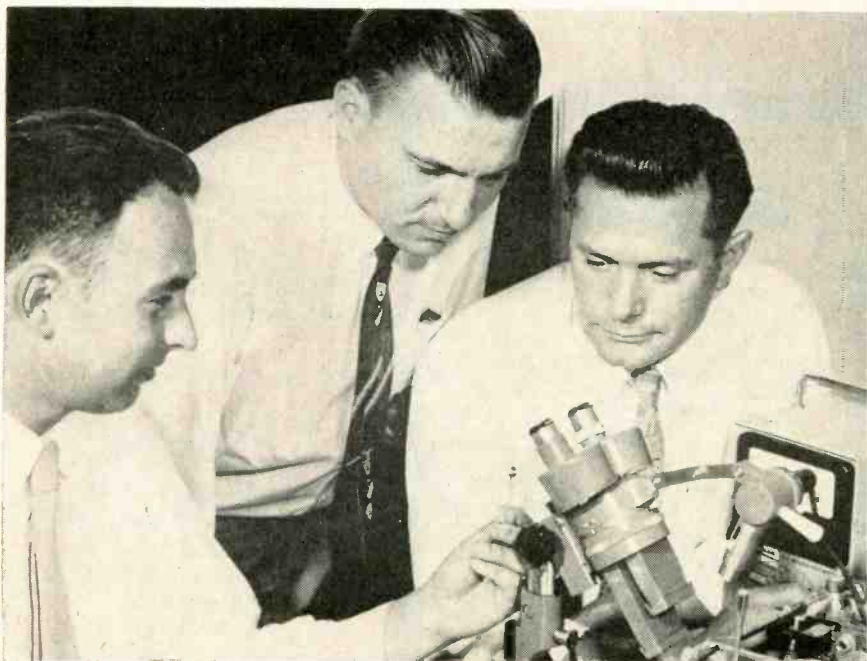

**TEAMWORK** of these three men resulted in the spacistor, being held by Hermann Statz before Robert Pucel (center) and Conrad Lanza

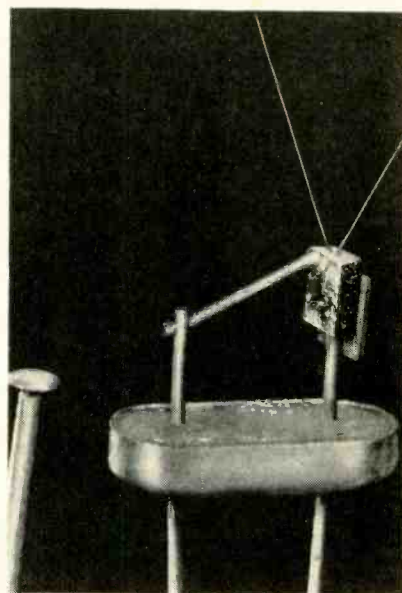

**PINHEAD** and transistor base show size of experimental spacistor assembly. Thin leads are modulator and injector

for example, it should be possible to operate at up to 500 C, to meet requirements for missiles and aircraft of the future.

► **Construction**—The end of a pellet of semiconductor material is soldered to the collector lead. A base connection is made to the other end of the pellet.

In an intermediate space-charge region on the pellet are mounted a tungsten-wire pressure contact serving as injector and a gold-wire

(Continued on page 12)



**2N344/SB101**  
for Medium Gain Amplifiers

	Min.	Typ.	Max.
$h_{fe}$	11	23	83
$f_{max}$	30	45	—



**2N345/SB102**  
for High Gain Amplifiers

	Min.	Typ.	Max.
$h_{fe}$	25	40	110
$f_{max}$	30	45	—

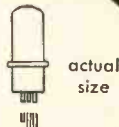
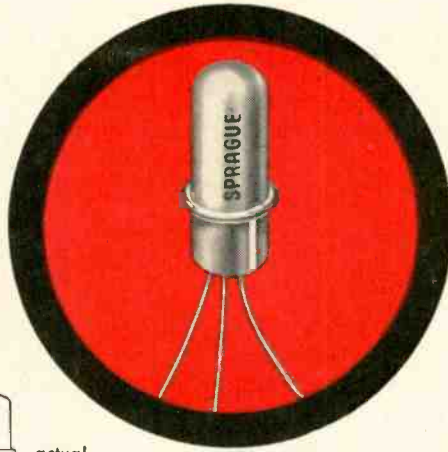

**2N346/SB103**  
for High Frequency Oscillators

	Min.	Typ.	Max.
$h_{fe}$	10	—	—
$f_{max}$	60	90	—

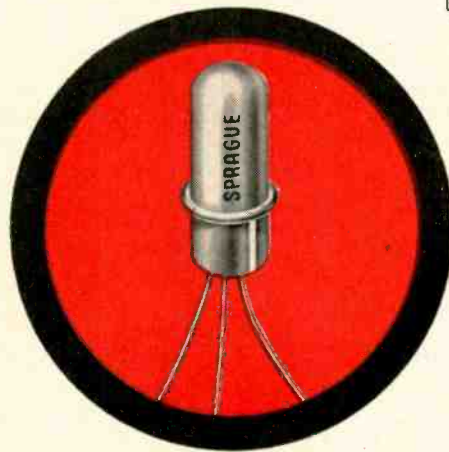

**2N240/SB5122**  
for Computer Switching

	Min.	Max.
$h_{fe}$	16	—
$f_{max}$	30	—
$T_s$	—	80



**IN VOLUME PRODUCTION**

*Now!*

For general high frequency applications, and for high speed computer switching circuits, design around Sprague surface barrier transistors. They are available now in production quantities from a completely new, scrupulously clean plant, built from the ground up especially to make high quality semi-conductor products.

The four transistor types shown are the most popular. Orders for these units are shipped promptly. What's more, surface barrier transistors are reasonably priced. High quality and excellent electrical characteristics make them an economical solution to many difficult circuit requirements.

Sprague surface barrier transistors are fully licensed under Philco patents. All Sprague and Philco transistors having the same type number are manufactured to the same specifications and are fully interchangeable. You have *two* sources of supply when you use surface barrier transistors!



WRITE FOR COMPLETE ENGINEERING DATA SHEETS ON THE TYPES IN WHICH YOU ARE INTERESTED. ADDRESS REQUEST TO THE TECHNICAL LITERATURE SECTION, SPRAGUE ELECTRIC CO., 35 MARSHALL ST., NORTH ADAMS, MASS.

TRANSISTORS • RESISTORS • MAGNETIC COMPONENTS  
CAPACITORS • INTERFERENCE FILTERS • PULSE NETWORKS  
HIGH TEMPERATURE MAGNET WIRE • PRINTED CIRCUITS



alloyed contact containing p-type doping material to serve as modulator. The injector and modulator are input leads, while base and collector provide the output.

► **How It Works**—Three d-c voltage sources make the injector, modulator and collector all positive with respect to the base. The input signal is applied in series with the modulator bias battery, and the corresponding amplified output signal is obtained across the load in series with the collector battery. At low frequencies, the resulting power gain is over 70 db. Voltage gains of 3,000 have already been achieved with the present input impedance of 30 megohms.

► **Status**—Though still in the research stage, the new spacistor shows great promise for important airborne and portable application where both tubes and transistors are today inadequate. For communication systems in the range from 1,000 mc to 10,000 mc it appears particularly attractive, because of its excellent frequency response combined with the small size and low power drain of transistors. Theoretical life is unlimited, both input and output impedances are very high, and multiple-stage circuitry is as simple as for vacuum tubes.

## Hotels Are Big Market For Gear

Fifty-million dollars spent last year on electronic systems

PUTTING electronics into a hotel having more than 1,000 rooms costs the owner \$300,000 to \$500,000. This estimate includes items like tv and radio sets, public address systems, heating and air-conditioning controls, closed-circuit tv.

There are about 100 U. S. hotels with more than 1,000 rooms. Only a handful have been built in the past few years.

► **Market**—There are 14,000 hotels with less than 1,000 rooms in the

U. S., according to the American Hotel Association Red Book director. These contain some 1.4 million rooms, represent a fat market for things like tv sets and electronic controls.

In 1952, 40 percent of guest rooms in U. S. hotels had tv sets an AHA survey showed. Twenty-four percent of public areas (lobbies, cocktail lounges) had sets. Although unwilling to estimate present degree of saturation, AHA notes that in past year rate of installing tv sets has increased sharply.

► **Service**—In some hotels guests

can register from their cars, dealing with clerks over closed-circuit tv. Electronically controlled elevators speed guests to rooms. Maids are routed to rooms when check-outs are reported via special intercom circuits.

Heating, air conditioning, ventilation is becoming electronically controlled. Minneapolis-Honeywell expects to sell \$5-million worth of this equipment annually in ten years.

Hotels spent \$50 million in 1956 for electronic gear, its installation and maintenance, guesses Eli M.

(Continued on page 14)

## Business Briefs

► **Purchase of Fairchild Engine & Airplane's Electrotechnics division by Mid-Continent Manufacturing's Datran Electronics division announced**

► **Merger plans of P. R. Mallory of Indianapolis and Radio Materials of Chicago disclosed. Stockholders of the Chicago concern are to receive 176,488 shares of Mallory common stock for their Radio Material shares: Mallory common closed at 46¼ on date of announcement. At that price the Mallory stock payment would be worth \$8.2 million**

► **Stockholders of Thompson Products meeting this month to vote on proposal to issue \$20 million in convertible subordinated debentures. Proceeds will be used to provide additional working capital and to enable company to take advantage of growth opportunities**

► **Private placement of 100,000 shares of common stock of Consolidated Electrodynamics through Blyth & Co. recently announced. The \$4.3 million realized from the placement will provide working capital needed for company growth**

► **Jointly-owned affiliate formed by Amphenol Electronics of Chicago and Gas Purification and Chemical Co., Ltd. of Great Britain. The new company, Amphenol Great Britain Ltd., will manufacture and sell Amphenol products under an exclusive license in the United Kingdom and Commonwealth nations. Gas Purification and Chemical is an investment company with 17 subsidiary companies intimately connected with the English electronics industry**

► **Merger agreement concluded between Digitronics Corp. and Key Electric Corp., both of Long Island, N. Y. Digitronics Class A stock will be exchanged for all outstanding stock of Key Electric**



Exclusive  
with ARNOLD



## ... SENDUST POWDER CORES

They use NON-STRATEGIC MATERIALS  
... you can avoid alloy shortages

Try  
SENDUST CORES  
in these typical  
applications

- Cores for loading coils
- Cores for filter coils
- Transformer cores for voice and carrier frequencies

Write for a copy of the Sendust Core Bulletin SDC-110, containing data on standard core sizes, electrical and magnetic properties, standard permeabilities, etc.

ADDRESS DEPT. E-78

Arnold sells SENDUST Powder Cores in this country under exclusive license from The Tohoku Metal Industries Co., Ltd., of Japan. They are available in a wide selection of sizes, ranging from .800" O.D. to 3.346" O.D.—and in permeabilities of 10, 13, 25, 30, 50 and 80, although not all sizes are available in all permeabilities.

SENDUST cores possess magnetic properties that are generally superior to iron powder cores, but inferior to Mo-Permalloy powder cores in the audio and carrier frequency range. The eddy current loss for SENDUST

cores is lower than that of Mo-Permalloy powder cores, but the hysteresis loss of SENDUST cores is substantially higher, and they also have higher values of electrical resistivity. In other characteristics of powder cores, the two types are somewhat similar, but SENDUST cores contain no scarce or strategic materials and can offer a core source in times of alloy shortage.

Sample SENDUST cores as well as production quantities are available from stock. For more detailed information, send for technical data sheet SDC-110.

WSW 6320

## THE ARNOLD ENGINEERING COMPANY



Main Office & Plant: Marengo, Illinois

Repech Pacific Division Plant: 641 East 61st Street, Los Angeles, Calif.

District Sales Offices:

Boston: 200 Berkeley St.

Los Angeles: 3450 Wilshire Blvd.

New York: 350 Fifth Ave. Washington, D.C.: 1001-15th St., N.W.

Lurie, president of American Communications Corp. He sees 25-percent increase in 1957.

## Microwave Energy Freeze-Dries Food

Dried foodstuffs can be stored indefinitely without refrigeration

NEW TECHNIQUES for preserving food without refrigeration uses microwave energy for freeze-drying

perishables. Process, still in laboratory stages, was announced to food technologists by Raytheon's food laboratory.

Foodstuffs are held in vacuum at below-freezing temperatures while microwave energy is applied. As food dries, energy bypasses dried portions, follow receding ice volume to center of food.

► **Advantages**—Process requires only 6 hours; conventional procedures take 24-36 hours. Dried products can be held indefinitely at room temperatures. Conventional methods use heat, run risk of damaging food as dried outer parts,

acting as insulator, force drying temperature up.

► **Flavor**—Nutrients are safeguarded in the microwave process and there is no significant alteration in flavor. Dried foodstuffs can be restored to original freshness by being immersed in water, which is soaked up like a blotter.

► **Applications**—Army and Navy are the most likely users of foods prepared this way, since its volume is strikingly reduced (three-quarters of a steak is water) and refrigeration unnecessary. Hospitals may use dried body tissue.

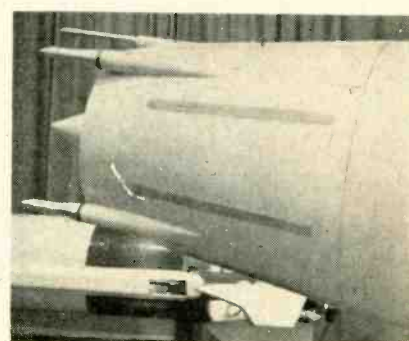

THREE views of missile show antenna types used on beam-rider as . . .

## Navy Unveils Operational Version of Talos Missile

Electronics involved still kept under wraps at military electronics conference

PRODUCTION of the Talos missile, shown publicly for the first time at the national military electronics conference, is proceeding under a \$27-million contract received by Bendix Aviation early this year. Estimates of electronics share in this project were unavailable for security reasons.

Close inspection of the device however gives some idea of the type of electronics employed.

► **Front-end**—Nose of the missile contains eight flush-mounted strip antennas and four probe-type units as shown in the photographs. Fifth probe may possibly be used to sense yaw or angle-of-attack.

The missile switches to a homing system during the final phases of attack, thus it seems reasonable that one set of antennas guides the missile up the ground-based radar beam until switch-over when the other set takes over for the final attack.

► **Packaging**—Missile's flight-sustaining power is obtained by ramjet principle requiring hollow construction (center photo). All electronic equipment must therefore be housed in an annular ring about 4-inches thick. Packaging and temperature requirements for components would appear to be more stringent owing to their inclusion in the shell of such a stovepipe.

► **Reliability**—In a talk to the IRE members, Lt. Gen. C. S. Irvine, USAF, pointed out that during the

next ten years speeds of Mach 10 and altitudes far exceeding anything now known will require electronic devices that are absolutely reliable.

To achieve this end a concerted effort on the part of the entire electronics industry now to improve the reliability of present-day missiles as well as manned aircraft.

### VHF Controls Power Plants

VHF RADIO SIGNALS are now being used to control automatically two hydroelectric generating plants. This is part of an experiment to

(Continued on page 16)



# need semiconductor production equipment?

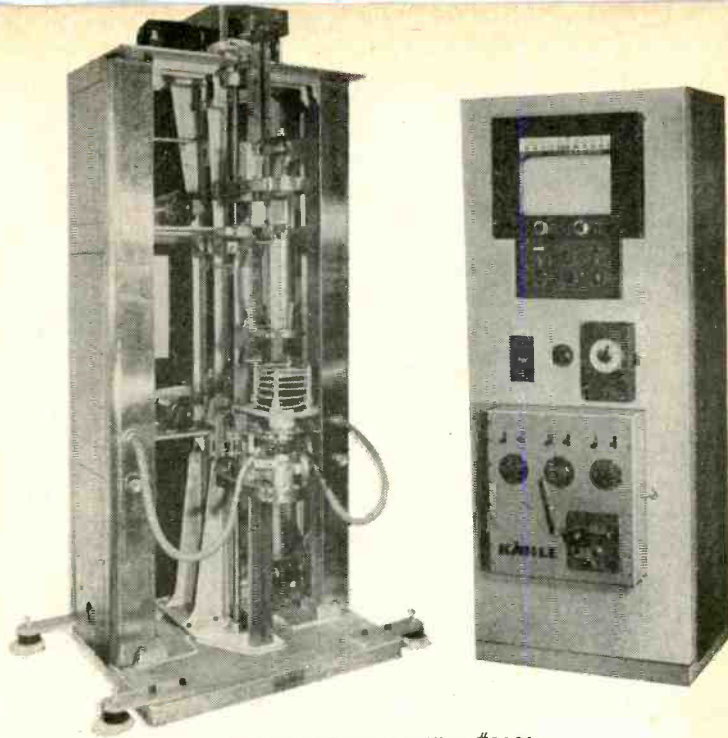

CRYSTAL GROWING MACHINE #2901  
FOR GERMANIUM AND SILICON CRYSTALS

**KAHLE'S  
MACHINE DESIGN,  
DEVELOPMENT AND FABRICATION  
SERVICES  
ARE THE NO-RISK ANSWER**

When you work with Kahle, the end result is assured . . . because all Kahle Machines are tested under *your* actual production conditions before shipment. In addition each machine is the result of Kahle's continuous experience which dates back to the days of the old carbon lamp.

But Kahle is modern, too . . . having *already* manufactured machines for every semiconductor production process. Their outstanding production records achieved for leading companies are available for your inspection.

Economy is another mark of a Kahle machine . . . hundreds of standard models can help solve your problems . . . when required, a special design is quickly and effectively created.

Relieve your engineering staff . . . assign the design, development and fabrication of production machinery and equipment to Kahle.

For an individual analysis of your problem, write outlining details.

## GLASS DIODE PRODUCTION OPERATIONS PERFORMED BY KAHLE MACHINERY:

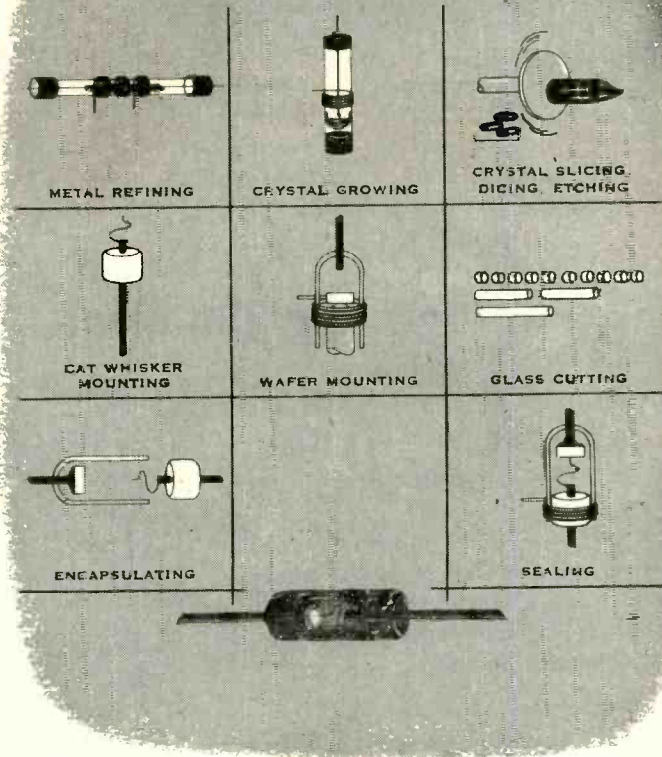

# KAHLE

## ENGINEERING COMPANY

GENERAL OFFICES:  
1357 SEVENTH STREET  
NORTH BERGEN, N. J.

PLANTS:  
SEVENTH STREET, NORTH BERGEN, N. J.  
HUDSON AVE., UNION CITY, N. J.

DESIGNERS AND BUILDERS OF SPECIAL AUTOMATIC AND SEMI-AUTOMATIC EQUIPMENT FOR ALL INDUSTRIAL OPERATIONS

Circle 59 Readers Service Card

see if standard f-m equipment designs will transmit reliably enough for automatic control.

Nova Scotia Light and Power has nine plants, six of which are operated automatically from one control center. They are close enough to control point to be connected by land lines. The seventh will be hooked on shortly.

The remaining two, Nietaux and Paradise, are so distant that the cost of land lines would be excessive. Since only a small number of channels is needed, multichannel microwave was discounted as being wasteful and expensive.

Radio was tried using vhf. Major change required was switching from tone to d-c keying. During the past year the new technique had its bugs worked out. For example, a separate power supply was added so that the receiver would operate during transmissions. The operation is now rated a success. Other Canadian power firms have expressed interest.

There is one drawback to similar operations in the U. S. The part of the spectrum used is in the 152-174 mc band. This is reserved for mobile systems in the U. S.

## Military Electronics

► **Mobile combat computer** for solving military problems ranging from battle strategy and tactics to logistics is being developed by Sylvania under \$1-million plus Army contract.

MOBIDIC (mobile digital computer) will fit into 28-ft. air-conditioned trailer. Special uses are combat surveillance, scientific or analytic computation, air traffic control and artillery target assignment.

► **High-intensity noise-system**, developed by RCA, permits quick, economical pre-flight laboratory tests of electronic components and assemblies used in jet aircraft and guided missiles. Equipment simulates in-flight noises up to 145 db, minimizes costly operation of jet engines to perform environmental component testing.

► **High-speed TRANSAC C-1,100**, Philco's new Transistor Automatic Computer, will go into one of Navy's jet fighters. Occupying less than four cu ft, TRANSAC handles computational problems encountered in flight.

► **Transistorized intercommunications system (ICS)**, first installed in Douglas' A3D Skywarrior over a year ago, will be adapted to all versions of the A3D and the AD-5Q.

► **New series of electronic data processing machines** will go into operation at Hill AFB, Utah this fall.

## Computers Get Smarter, Study Semantics

Cal Tech man teaches one how to translate; another is ready to control plant processes

ADD two more items to computer files. From California come reports of an idiomatic translator and a transistorized process control computer for industry.

► **Linguist**—At a press show arranged by ElectroData, a Cal Tech technician showed how to turn an ordinary \$250,000 computer system into a linguist.

Peter Toma made a Datatron translate excerpts from Russian, French, German and Spanish into English. The computer gaged a bit on German sentence structure but otherwise did fine.

► **Semantics**—Toma's system as-

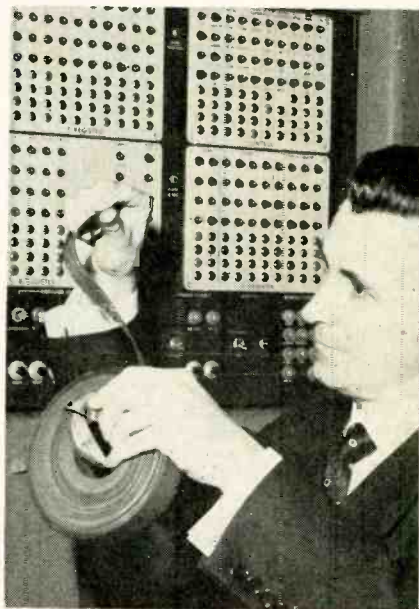

**PUNCHED** paper tape feeds computer that translates Russian, French, German and Spanish into English.

signs semantic codes to sentence units. It is intended to interpret idiomatic meaning rather than give word-for-word translations.

Special 500-word dictionaries are coded on paper tape then fed into the computer's memory. Items to be translated are coded and compared with the dictionary.

► **Future**—In time, Toma hopes to store complete languages in high-capacity magnetic tape memory files. He figures there are no more than two million sentence units in most languages.

► **Processing**—A new transistorized digital computer made by Ramo-Wooldridge is designed for process control in such industries as oil, chemicals, metals and paper, it can also handle scientific com-

(Continued on page 20)



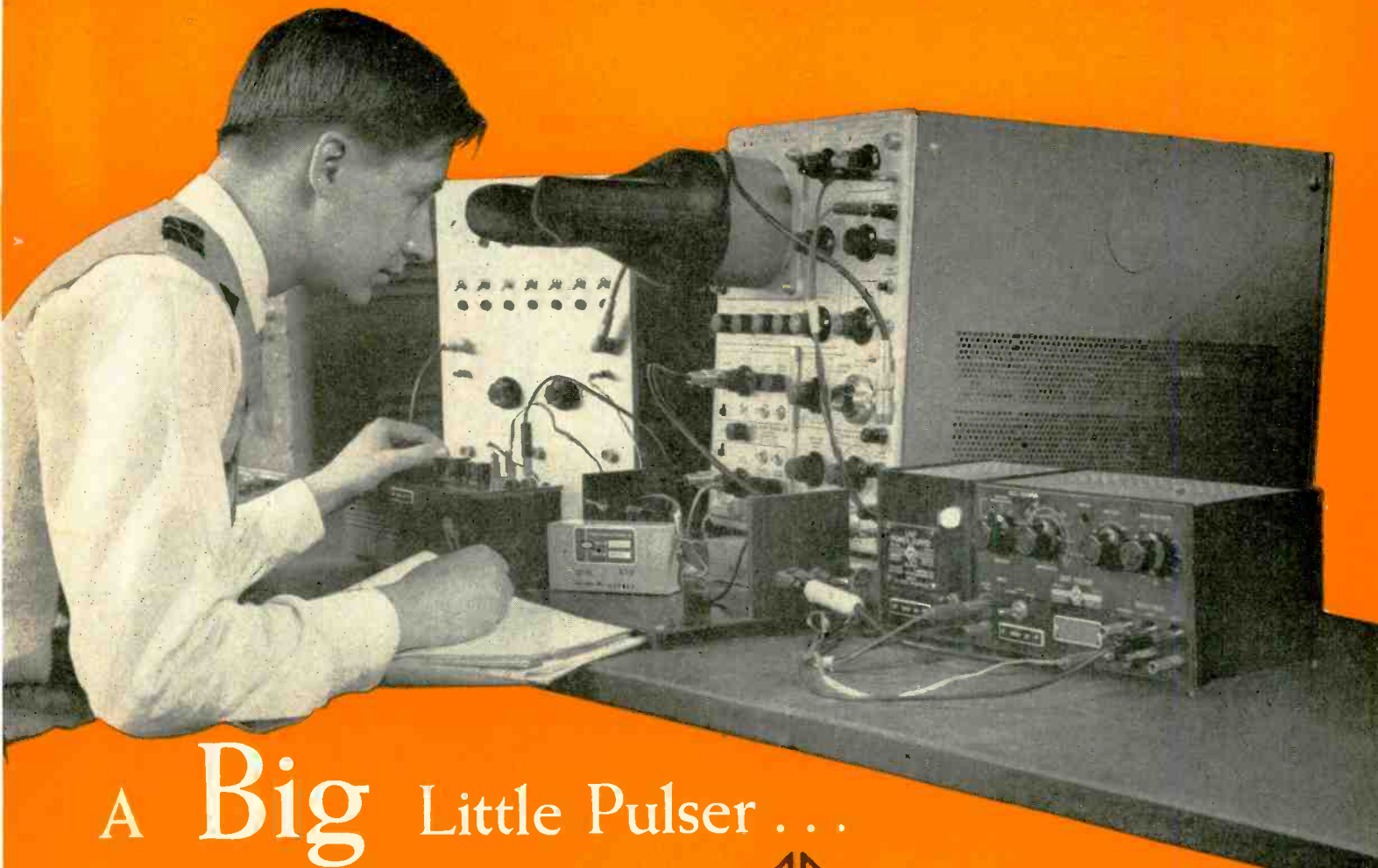

# A Big Little Pulser . . .

**GR** Type 1217-A Unit Pulser, \$235

Photo courtesy Richard D. Brew and Company, Inc.

*Low Cost      Small Size      General Ease of Operation*  
*Wide Range, both in Pulse Width and Repetition Rate*  
*Good Pulse Shape even at short pulse durations*  
*Hard-Tube rather than Gas-Tube operation makes*  
*high repetition rates possible — permits bright*  
*and easily discernable oscilloscope traces at fast sweep speeds*  
*Built-in Time Delay allows the leading edges of pulses*  
*to be visible on most oscilloscopes*  
*Several Unit Pulsers can be easily combined*  
*to form an economical generator of composite signals*

. . . These are but a few of the outstanding features built into the General Radio Unit Pulser to make it one of the most versatile pulse generators available today. In short, the Pulser has been designed to meet the need for a low-cost, general-purpose instrument of laboratory-quality.

Typical of Pulser users is Richard D. Brew and Company, Inc., Concord, New Hampshire, manufacturer of ultrasonic, lumped-constant and distributed-constant delay lines. They use the Pulser both in development and production testing. The varied requirements of these measurements call for flexible test equipment, and Brew, like many others, has discovered that the Unit Pulser's built-in features give "built-in versatility" at no extra cost.

*Write for the Pulse Equipment Bulletin for full information.*

**Repetition Rate:** 30 and 60 cycles; 100c to 100 kc in X1, X2, and X5 steps; 15c to 100 kc continuous with external drive (25v rms is sufficient for locking)

**Pulse Duration:** 0.2  $\mu$ sec to 60,000  $\mu$ sec

**Pulse Shape:** Positive and negative pulses available; rise time 0.05  $\mu$ sec, fall time 0.15  $\mu$ sec; pulse top is flat to within 5% of maximum amplitude; overshoot is adjustable

**Amplitude:** Continuously variable; 20 volts maximum open circuit for either polarity; negative pulse of 50 volts if positive terminal is grounded

**Output Impedance:** 200 ohms, positive pulses; 1500 ohms, negative pulses

**Price:** 1217-A Unit Pulser, \$235

1203-B Unit Power Supply, \$40

**Type 1219-A Unit Pulse Amplifier, \$200:** Provides a maximum of 55 watts peak power at a wide range of impedances; current pulses up to 600 ma, and voltage pulses in excess of 250 volts at pulse durations as small as 0.1  $\mu$ sec and repetition frequencies up to 2 Mc.

## GENERAL RADIO Company

275 Massachusetts Avenue, Cambridge 39, Mass., U.S.A.

Broad Avenue at Linden, Ridgefield, N. J. NEW YORK AREA 1000 N. Seward St. LOS ANGELES 38

8055 13th St. Silver Spring, Md. WASHINGTON, D. C.

1182 Los Altos Ave., Los Altos, Calif. SAN FRANCISCO

1150 York Road, Abington, Pa. PHILADELPHIA

6605 W. North Ave., Oak Park, Ill. CHICAGO



All G-R Products  
are now covered by a

2-Year Warranty

**NEW** in the JETEC 30 package



**PNP  
Fusion-Alloy**

# GERMANIUM TRANSISTORS

0.200" pin circle diameter

Designed for printed circuits and automation

-65°C to +85°C junction operating range

Extreme reliability due to Raytheon's fusion-alloy process

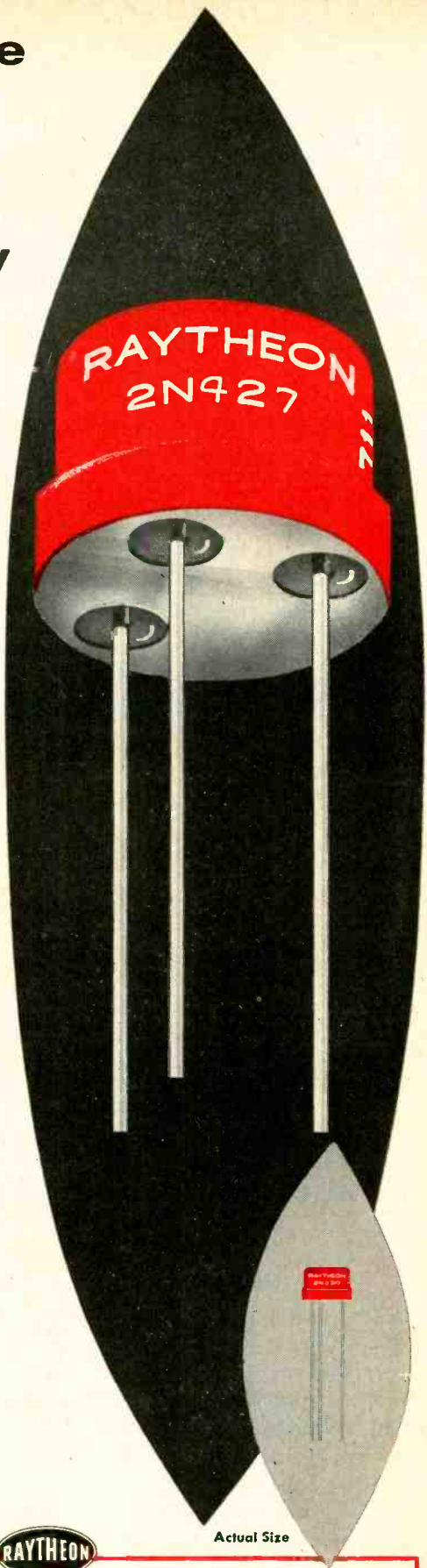

**NEW RAYTHEON TRANSISTORS FOR COMPUTER SERVICE**

Type	V <sub>ce</sub> max. Volts	f <sub>aco</sub> Mc	hfe <sub>1</sub> (I <sub>b</sub> = -1mA)	hfe <sub>2</sub> (I <sub>b</sub> = -10mA)	Grounded Emitter Switching Data at I <sub>c</sub> = 50mA			
					I <sub>b</sub> "on" and "off" mA	Rise Time μs	Storage Time μs	Fall Time μs
2N425	-20	4	30	18	5.0	0.5	0.25	0.3
2N426	-18	6	40	24	3.3	0.5	0.25	0.3
2N427	-15	11	55	30	2.5	0.4	0.25	0.3
2N428	-12	17	80	40	1.7	0.1	0.25	0.3

For above four types ... I<sub>c</sub> = -400mA max.; Z<sub>sat</sub> = 1.5 ohms for I<sub>c</sub> of 100 mA

**RAYTHEON TRANSISTORS FOR SPECIAL PURPOSE RF SERVICE**

Type	Replaces	V <sub>ce</sub> max. Volts	I <sub>c</sub> max. mA	f <sub>aco</sub> Mc	C <sub>c</sub> μμf	Beta		Power Gain at 2Mc db	Extrinsic Base Resistance ohms
						1Kc	1Mc		
2N416	2N113/CK761	-10	-200	10	12	45	10	18	60
2N417	2N114/CK762	-10	-200	20	12	75	20	25	75

**RAYTHEON TRANSISTORS FOR PORTABLE RADIOS**

Type	Replaces	Circuit Usage	V <sub>ce</sub> max. Volts	f <sub>aco</sub> Mc	C <sub>c</sub> μμf	Power Gain at 455Kc db	Conv. Gain db
2N413	2N111/CK759	Oscillator	-15	3	12 av.	—	—
2N413A	2N111A/CK759A	IF Ampl.	-15	3	12 ±2	32	—
2N414	2N112/CK760	Converter	-15	5	12 av.	—	26
2N414A	2N112A/CK760A	IF Ampl.	-15	5	12 ±2	35	—
2N415	2N271/CK766	Converter	-10	10	12 av.	—	30
2N415A	2N271A/CK766A	IF Ampl.	-10	10	12 ±2	39	—

For above six types ... I<sub>c</sub> = -200mA max. "A" types are for IF amplifiers with fixed neutralization

For all types on this page { Dissipation Coefficient = 0.4°C/mw (free air)  
Collector Cut-off Current ≅ 1.0 μA at -20V.

## SEMICONDUCTOR DIVISION

Silicon and Germanium Diodes and Transistors • Silicon Rectifiers



NEWTON, MASS.: 55 Chapel St. • Bigelow 4-7500  
NEW YORK: 589 Fifth Ave. • PLaza 9-3900  
CHICAGO: 9501 Grand Ave., Franklin Park • TUXedo 9-5400  
LOS ANGELES: 5236 Santa Monica Blvd. • NORmandy 5-4221

Visit Raytheon Booths 2921-22, WESCON, San Francisco, August 20-23





# SEMICONDUCTOR DIODES and RECTIFIERS



All illustrations are actual size

## DIFFUSED JUNCTION SILICON RECTIFIERS

A STUD TYPE								B WIRE-IN TYPE			
Type	Peak Inverse Volts	Average Rectified Current Amps. (150°C)	Reverse Current (max.) at PIV $\mu$ A	Type	Peak Inverse Volts	Average Rectified Current Amps. (135°C)	Reverse Current (max.) at PIV $\mu$ A	Type	Peak Inverse Volts	Average Rectified Current Amps. (150°C)	Reverse Current (max.) at PIV $\mu$ A
CK846	100	1.0	2	1N253	95	1.0	10	1N537	100	0.25	2
CK847	200	1.0	2	1N254	190	0.4	10	1N538	200	0.25	2
CK848	300	1.0	2	1N255	380	0.4	10	1N539	300	0.25	2
CK849	400	1.0	2	1N256	570	0.2	20	1N540	400	0.25	2
CK850	500	1.0	2					CK844	500	0.25	2
CK851	600	1.0	2					CK845	600	0.25	2

## SILICON POWER RECTIFIERS

Type	Peak Inverse Volts	Average Rectified Current Amps. (125°C*)	Reverse Current (max.) at PIV mAdc
CK774	25	5	5
CK775	60	5	5
CK775-1	125	5	5
CK776	200	5	5
CK777	325	5	5

\*Case Temperature

## BONDED SILICON DIODES

Type	Peak Inverse Volts	Forward Current (min.) at +1V mAdc	Average Rectified Current mAdc (25°C)	Reverse Current $\mu$ A at V	
1N300	15	15	65	0.001	10
1N300A	15	30	80	0.001	10
1N432	40	10	55	0.005	10
1N432A	40	20	70	0.005	10
1N301	70	5	45	0.05	50
1N301A	70	18	65	0.05	50
1N460	90	5	45	0.1	75
1N460A	90	15	60	0.1	75
1N303	125	3	40	0.1	100
1N303A	125	12	55	0.1	100
1N433	145	3	40	0.1	125
1N433A	145	10	50	0.1	125
1N434	180	2	35	0.1	150
1N434A	180	7	45	0.1	150
1N302	225	1	30	0.2	200
1N302A	225	5	40	0.2	200
CK863	300	1	20	0.3	275
CK863A	300	3	30	0.3	275

## GOLD BONDED GERMANIUM DIODES

Type	Peak Inverse Volts	Average Rectified Current (max.) mAdc	Reverse Current at -10V $\mu$ A
1N305	60	125	2
1N306	15	150	2
1N307	125	50	5

## GENERAL PURPOSE GERMANIUM DIODES

Type	Peak Inverse Volts	Average Rectified Current (max.) mAdc	Reverse Current $\mu$ A at V	
1N66	60	50	800	-50
1N67	80	35	50	-50
1N68	100	35	625	-100
1N294	60	50	800	-50
1N297	80	35	100	-50
1N298	70	50	250	-40
VHF and UHF				
1N295	40	35	200	-10
CK715	40	35		



## SEMICONDUCTOR DIVISION

Silicon and Germanium Diodes and Transistors • Silicon Rectifiers

NEWTON, MASS.: 55 Chapel St. • Btgelow 4-7500  
 NEW YORK: 589 Fifth Ave. • PLaza 9-3900  
 CHICAGO: 9501 Grand Ave., Franklin Park • TUxedo 9-5400  
 LOS ANGELES: 5236 Santa Monica Blvd. • NOrmandy 5-4221

Visit Raytheon Booths 2921-22, WESCON, San Francisco, August 20-23

putation and data logging.

It will automatically read process instruments, compute relationship of readings to process objectives, compute control actions needed and activate process mechanisms or adjust control loops.

The computer, called the RW-300, is comparatively small, 55 by 28 by 36 inches and weighs 400 pounds.

► **New phase** — Ramo-Wooldridge people have been predicting for some time that computers are ready to move into a new phase of development. Most computers operate on descriptions without taking part in the processes described. Industry, they believe, needs take-part computers akin to those in automatic aircraft navigation and weapons control systems.

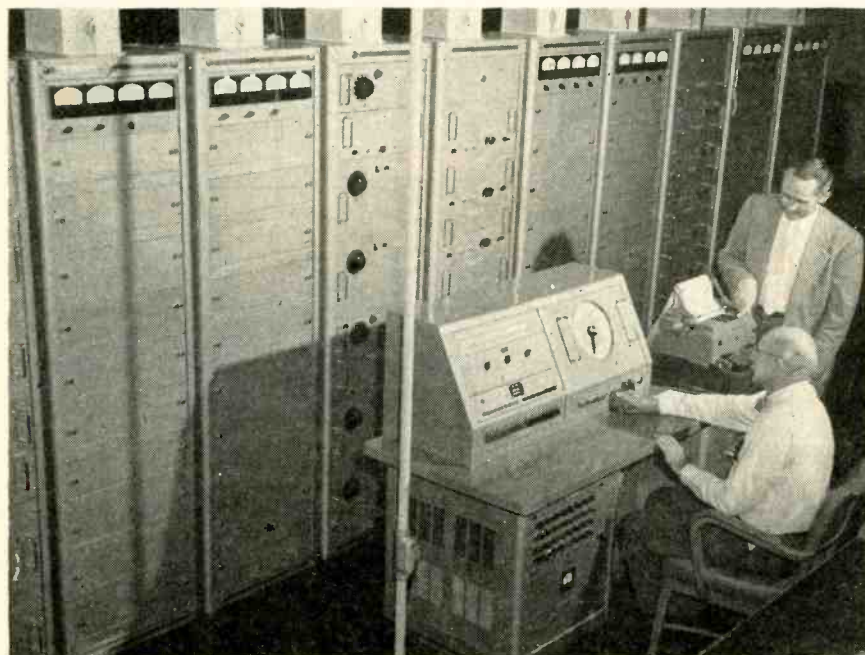

**OPERATOR** at console records four test readings for each of 800 tubes, transistors or crystal diodes as . . .

## Rack Cuts Test Time One-Third

EXPERIMENTAL electronic components are being tested at ARDC's Wright Air Development Center more accurately, with less personnel and in one-third the time by using an automatic testing device developed by Systems Development, Incorporated.

► **Testing**— Electron tubes, transistors and semi-conductors are placed into any of the automatic life test and data recording rack's 800 sockets. Four test points are provided for each socket. Tests, lasting as long as 1,000 hours, are then conducted without further attention by the operator. Results are recorded by electric typewriter.

When set on automatic, the control console gives accurate readings on all 800 specimens at the rate of less than 10 seconds per specimen. When the set is switched to manual operation a reading can be taken on a particular specimen.

Special environmental chambers for heat, vibration and altitude tests are currently being installed. Components will be placed in these chambers with lead wires connected to sockets in the automatic test specimen racks.

Complete environmental and age testing of components will then be possible without removing them from fixtures.

## Bank Teller-Vision Hastens Service



Closed-circuit tv camera, installed in the bookkeeping department of the Bank of Belmont, North Carolina, links the main building with its new Glenway drive-in branch, located 100 feet away. As shown above, requested information from the files is placed under the camera for transmission to RCA portable receiver in branch.

## Hawaii Cable Ready This Fall

36-circuit, \$37-million project will provide operator dialing to phones on Oahu and mainland

FIRST undersea telephone link between Hawaii and the West Coast will go into operation in the fall after laying of two 2,400-mile cables. The \$37-million project will provide for operator dialing of calls over 36 voice circuits.

► **New cable**, which will connect Point Arena, Calif. and Hanauma Bay, Oahu, is 85 percent owned by the AT&T Long Lines Department and 15 percent owned by the Hawaiian Telephone Co. It will provide three times the capacity of the 14 existing radiotelephone circuits which are subject to atmospheric disturbances and fading.

Each of the twin cables contains 57 amplifiers spaced about 43 mi apart. The amplifiers have a life

(Continued on page 22)



# Barry's New "Lo" Mount Meets MIL-C-172B at low cost

— with this extra vibration isolation that adds reliability to your design.

We designed for lower cost — and developed a better mount for MIL-C-172B. Even at 10° inclination, the new Model L44 Mount performs effectively. And its other characteristics, too, far exceed requirements of MIL-C-172B.

The basically simple and versatile construction of this new isolator lets us match characteristics to your specification. Your design now gains added reliability with a mount that more than satisfies MIL-C-172B — and at low cost.

## Extra-low transmissibility and low natural frequency

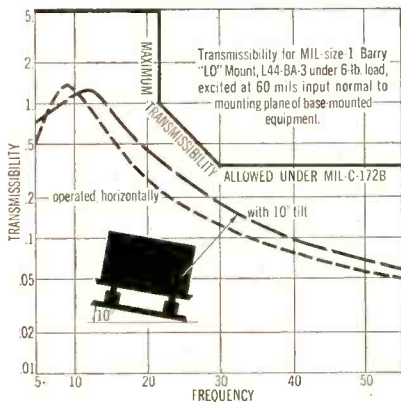

This low transmissibility — below 2 at resonance in all load ranges — is a major advantage of the Model L44 isolator. It accommodates high-amplitude inputs, even at resonance, without snubbing. Typical isolation at 10° inclination is also shown above.

## Very low rocking modes

In base-mounted systems, transmissibility of rocking modes under horizontal vibration is reduced to the point where they are indiscernible. This is due to the combination

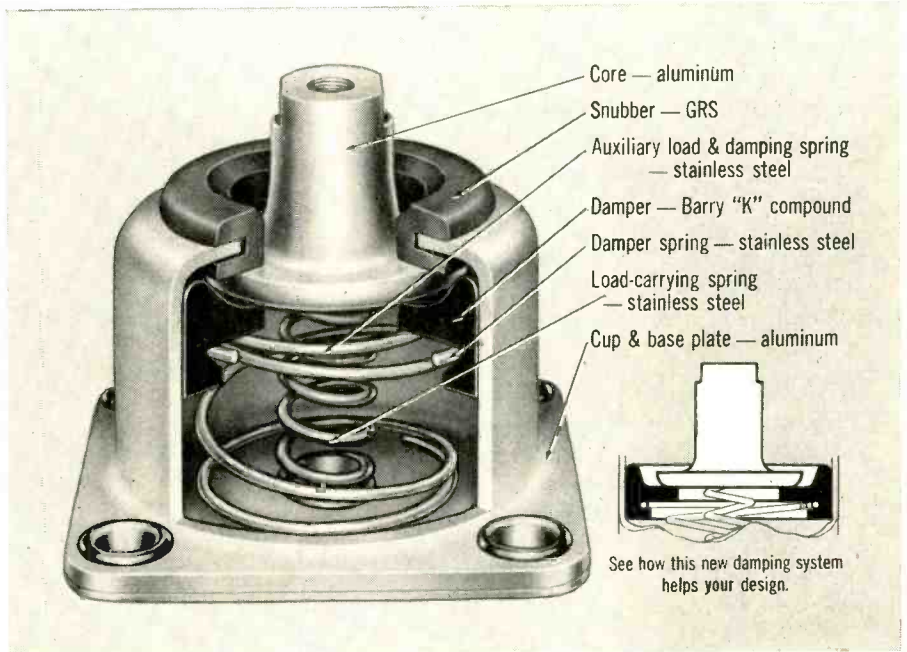

MIL-size 1 "Lo" Mount shown 1½ times actual size

of inherently low ratio of horizontal-to-vertical stiffness plus horizontal self-centering friction damping.

## For center-of-gravity designs

Independent horizontal damping makes the "Lo" mount especially suited for installation in the plane

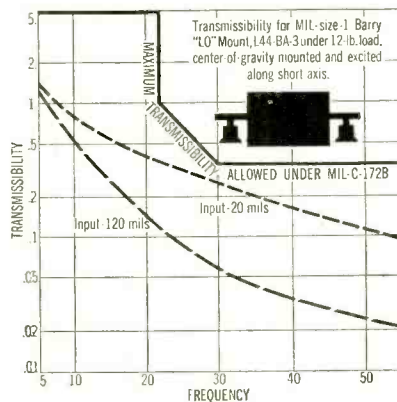

of center-of-gravity of the equipment. The natural frequency of the system shown above is below 5 cps.

## Controllable characteristics

These exceptional characteristics result from the unique Barry spring and friction-damping design pictured above. And these characteristics can be controlled to give high performance with a wide variety of equipment. Horizontal and vertical damping can be controlled independently. Special versions of the "Lo" mount will control transmissibility at resonance for a given input . . . or handle very high-amplitude inputs at resonance without snubbing.

## Physical characteristics

The L44 Mount is dimensionally interchangeable with MIL size 1 isolators. It is available in 7 load ranges from 0.25 to 10 pounds per mount in long- and short-core models. It meets all environmental as well as vibration requirements of Procedure I, MIL-E-5272A. Temperature range is -85F to 250F. Weight is 1½ ounces per mount.

## SEE IT AT WESCON

The new Barry "Lo" Mount will be on display at Wescon, with engineers on hand to tell how you can use it in your design.

Write today for Data Sheet 57-05.

**BARRY**  
**CONTROLS**  
INCORPORATED

WESTERN DIV. BURBANK, CAL.

**BARRY B MOUNT**

SALES REPRESENTATIVES  
IN ALL PRINCIPAL CITIES

707 PLEASANT STREET, WATERTOWN 72, MASSACHUSETTS

expectancy of 20 years and use three vacuum tubes plus 60 other components. They were manufactured at the Hillside, N. J. plant of Western Electric.

► **Teletypewriter** and radio broadcast transmission will also be provided over the new cable system, which is similar in design and construction to the 2,250-mi Atlantic cable system and the 900-mi Port Angeles, Wash. to Ketchikan, Alaska cables. The Hawaiian cable will be in deeper water, striking a depth of three miles at one point.

► **An operator** in Honolulu will be able to dial a number in any one of about 6,500 mainland communities. Similarly, operators in hundreds of mainland cities can dial any subscriber on Oahu, where 95 percent of Hawaii's telephones are located.

About 2,500 volts are required from each end to operate the system.

## FCC Actions

► **Gets a new commissioner.** Upon retirement of chairman George C. McConnaughey, John C. Doerfer succeeded to chairmanship and new commissioner Frederick W. Ford was added. Ford was chief of FCC Broadcast Bureau's hearings division

► **Ceases to issue more f-m broadcast simplexing authorizations.** F-m stations presently engaged in functional music operations on a simplex basis are given six months to switch to multiplex

► **Sets up two committees** to prepare United States proposals for revision of International Telegraph Regulations. Revisions are among the things to be discussed at the Administrative International Telegraph Conference in its fall meeting in Geneva, Switzerland

► **Schedules RETMA witness** W. R. G. Baker as last man to testify in hearings concerning frequencies above 890 mc. Baker will present association's views in September after Commission's recess

► **Grants authority** to the Grace Immanuel Baptist Church, Detroit, Mich., to transmit religious programs from Detroit for broadcast by station CKLW, Windsor, Ontario, Canada



ONE of the forty-six men assigned to a special State Police unit along the Indiana Toll Road works to keep the highways safe as . . .

combination microwave-vhf system provides complete integration of mobile radio units, telephones and teletypewriters located at various points of the road from one end to the other.

► **Network**—The system was engineered by General Electric at a cost of a half-million dollars. In all, the system provides seven microwave stations, 10 vhf base stations, a dozen fixed station units for toll plazas and 65 mobile radios for use in police cars, maintenance vehicles, tow trucks and snow-removal units.

Engineers who designed the system say the police-maintenance microwave hookup is 110 miles long, providing instantaneous communication along all 157 miles of the twin-lane highway.

Each interchange in the system is equipped with a vhf base station for quick communication to five major maintenance buildings housing offices, police personnel, maintenance trucks and road machinery. All five maintenance

(Continued on page 24)

## High-Band Mobile Patrols Turnpikes

**Police-maintenance microwave-vhf hookups provide quick control**

EFFECTIVE communications are provided for law enforcement officers

and maintenance crews by a communication system in operation along the Indiana Northern East-West Toll Road. Extending in both directions from a control center near South Bend, the com-



# new!... printed circuit Continental Connector

Actual Size  
9<sup>27</sup>/<sub>32</sub>" long

LONGEST  
PRECISION MOLDED  
CONNECTOR KNOWN

ONE PIECE  
GLASS REINFORCED  
ALKYD MOLDING

EXTRA  
LONG  
CREEPAGE  
PATH

EXCLUSIVE  
DESIGN  
"BELLOWS"  
CONTACTS

SPRING TEMPER  
PHOSPHOR BRONZE  
GOLD PLATED  
CONTACTS

ANODIZED  
ALUMINUM  
SHIELD FOR  
HEAT DISSIPATION

\*Pat. Pending

designed for use in one of  
the country's largest military  
data processing systems

Again, Continental Connector proves its reliability and engineering know-how with this remarkable new printed circuit connector. Overall length is actually 9<sup>27</sup>/<sub>32</sub>"... the longest, single piece precision molded connector known!

Standard molding compound is high impact reinforced glass Alkyd (other molding materials available on request). 34 contacts have .250" spacing including heavy barriers for extra protection and long creepage path. Patented "Bellows Action" contacts are conservatively rated to accept printed circuit board thickness of .054 to .072", while maintaining low contact resistance and positive spring action grip over entire printed circuit contact area. Maximum board length is 8<sup>3</sup>/<sub>4</sub>". Self-alignment of "Bellows" Contacts\* allows for any residual warpage of printed circuit board. An anodized aluminum shield for dissipating heat is available as an optional accessory when required (see illustration).

Our engineering staff is available for developing other unique design printed circuit connectors that may solve your special connector problems. For complete technical specifications, write to Electronic Sales Division, DeJUR-Amsco Corporation, 45-01 Northern Boulevard, Long Island City 1, New York.

VISIT US AT WESCON SHOW BOOTH 1017

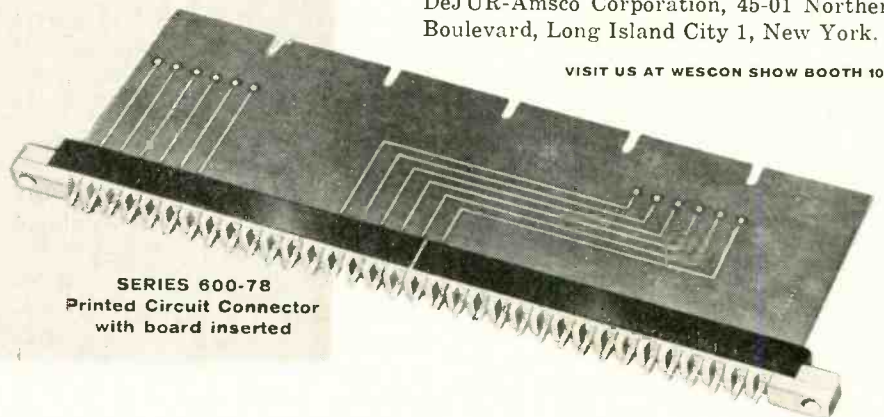

SERIES 600-78  
Printed Circuit Connector  
with board inserted

you're  
always  
sure  
with

# DeJUR

electronic  
components

progress in

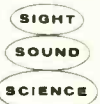

buildings have two identical vhf circuits, one for patrol use and the other for maintenance. Complete duplicate equipment has been installed for standby purposes, permitting automatic transfer to standby devices if some portion of the regular transmission fails.

Handsets and loud speakers are located at various places in each building. Speakers linked to the police radio system are located in the patrol barracks and those containing maintenance messages are installed in maintenance areas. Telephones in each of the maintenance buildings are linked with an automatic switchboard.

By dialing a code number, individuals using telephones in maintenance areas may be connected with the microwave transmission system.

The South Bend control center is operated by police personnel at all times. Lights on the control console indicate whether normal or standby equipment is in use at various points in the system. Light signals also show which base station receivers are in use and whether calls in some buildings are being originated with handsets.

► **Massachusetts**—The first portion of a half-million dollar communications system also installed by GE on the Massachusetts east-west turnpike is now in operation. High-band mobile two-way radio units were placed in service for state police patrolling the road as the new super-highway opened.

When completed, the system will be one of the most modern in the nation. One-hundred mobile radio units for police cars and highway maintenance crews will be controlled from a dispatch center at Chicopee, Mass., where vhf and microwave equipment will be linked to provide communications coverage for approximately 180 miles.

A selective-calling feature included in mobile units will assure privacy between departments using the combined police and highway maintenance facilities.

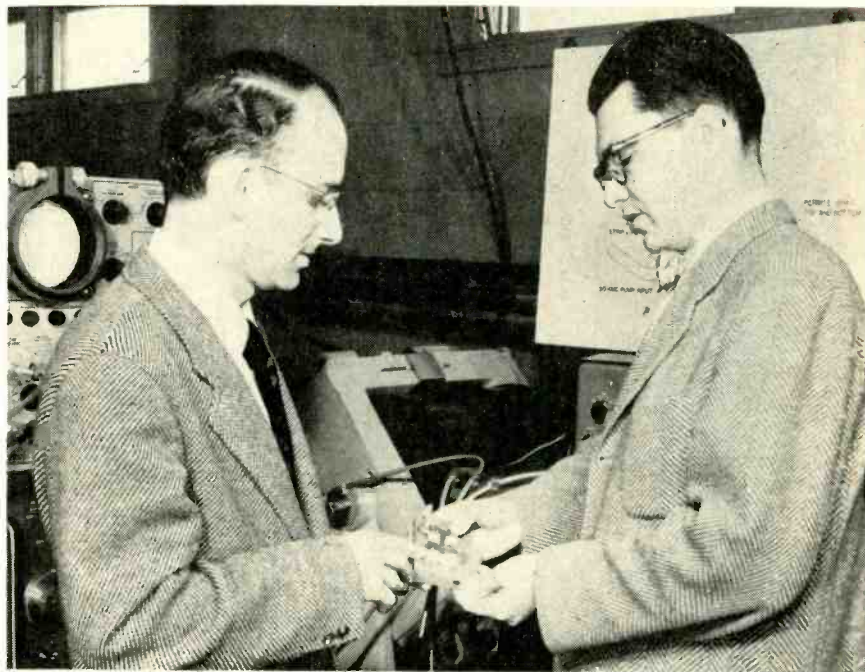

**NEW** experimental amplifier is checked prior to assembling into complete unit (below) for testing as . . .

## Solid State Gains New Amplifier

Experimental ferrite microwave device operates at room temperature

ATTESTING to the continued increasing interest in solid-state devices, the successful operation of a ferromagnetic amplifier in the microwave frequency range by Bell Telephone engineers marks another step forward in this field.

► **Principle**—Operation of the device is based on the fact that nonlinear coupling in a ferrite sample placed in a cavity which is simultaneously resonant at two signal frequencies will produce amplification or oscillation.

Microwave power at a frequency equal to the sum of the two signal frequencies coupled with a properly oriented d-c magnetic field causes gyromagnetic resonance at the sum frequency. Through nonlinear coupling in the ferrite, the lower frequencies can be amplified.

By increasing the sum-frequency power, oscillation at the lower frequencies can be produced. Also, frequency conversions can be made.

► **Tests**—In one experiment, a

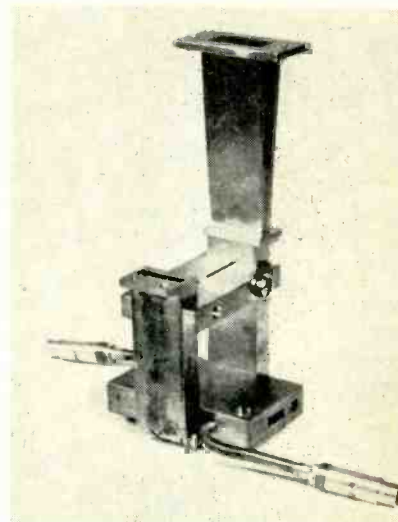

**EXPERIMENTAL** ferrite microwave amplifier

cavity was designed to be resonant at frequencies of 4,000 and 4,800 mc, with the sum-frequency set at 8,800 mc. Oscillations and frequency conversions were observed at both the lower frequencies.

► **Applications**—It appears that these amplifiers can be designed for any portion of the microwave spectrum and preliminary results indi-

(Continued on page 26)



now... **0 TO 32 VOLT,**  
**0 TO 25 AMPERE,** *low cost,*  
*continuously adjustable*

**DC POWER SUPPLY**

by **PERKIN!**

**IMMEDIATE DELIVERY...\$449.00†**

Thousands of electronics laboratories and aircraft firms are presently using the PERKIN Model M60V DC Power Supply as an economical and practical solution to their DC power needs where AC line stabilization and precise load regulation are not required.\*



Conservatively  
Designed

Smooth  
Stepless Voltage  
Control

No Tubes,  
Moving Parts  
or Vibrating  
Contacts.

Filtered

Model  
No. M60V

**SPECIFICATIONS:**

**DC OUTPUT:** 0-32 volts, 0-25 amps.

**REGULATION:** ±1% (a) at 28 Volts D.C. — increases to 2% max. over the range 24-32 V.; does not exceed 2 volts regulation over the range 4-24 volts D.C.; (b) from 1/10 Full Load to Full Load; (c) at a fixed AC Input of 115 volts.

**RIPPLE:** 1% rms @ 32V. and Full

Load — 2% rms max. @ any voltage above 4 volts.

**AC INPUT:** 115 Volts, Single Phase, 60 cps.

**MOUNTING:** Cabinet 20 3/8" wide x 16 1/2" deep x 13 7/8" high or 19" rack panel (19" wide x 14 3/4" deep x 12 1/4" high.)

**WEIGHT:** 130 lbs.

\* If these are required, write for specifications on Model MR 1040-30A (5-40V. @ 30 A) or 28-30 WXM (24-32 V. @ 30 A.), which are stabilized for AC line changes and regulated to ± 1/2%.

When you require a power supply, SPECIFY PERKIN, for a wider range of standard models and immediate delivery from stock. There are over 15,000 Perkin units in operation in industry today.

† For rack panel units without meters. Wire factory collect for prices for units with cabinet and meters.

For a prompt reply on your application,  
write factory on your letterhead.

**PERKIN**

**PERKIN ENGINEERING CORPORATION**  
 345 KANSAS STREET, EL SEGUNDO, CALIFORNIA • OREGON 87215

Immediate delivery on standard models available from factory and:

New York area office: Sales and Warehousing: 1060 Broad St., Newark 2, N.J., Market 3-1454  
 New England area office: 46 Amesbury, Lawrence, Mass., MURdock 3-3252

**SALES OFFICES:** Chicago: PA 56824 • Philadelphia: BR 5-2600 • Seattle: LA 9000 • Minneapolis: MI 6-2621 • Atlanta: TR 6-3020 • Winston-Salem: 4-0750 • Charlotte: ED 2-7356 • Redwood City, Calif.: EM 9-3354 • Albuquerque: 5-9897 • Phoenix: AM 5-0274 • Denver: AL 5-1196 • Euclid, Ohio: RE 2-7444 • Dayton: WA 5426 • Canada: Agincourt, Ontario: AX 3-7011 • Foreign: New York: BR 9-1296.

OTHER  
**PERKIN**  
 STANDARD

**DC POWER SUPPLIES**

**28 Volt Models**

Model	Volts	Amps	Reg.	AC Input (60 cps)	Ripple rms
28-5VFM	0-32 V	5	15-20% (24-32V range)	115 V 1 phase	2%
28-10WX	24-32 V	10	± 1/2%	100-125 V 1 phase	1%
MR532-15A	2-36V	15	± 1/2%	105-125V 1 phase	1%
28-15VFM	0-32 V	15	15-20% (24-32V range)	115 V 1 phase	5%
M60V	0-32V	25	± 1%	115V 1 phase	1%
MR1040-30A	5-40V	30	± 1%	100-130V 1 phase	1%
28-30WXM	24-32V	30	± 1/2%	100-125V 1 phase	1%
28-50WX	24-32 V ±10%	50	± 1/2%	230 V* 3 phase	1%
MR2432-100XA	24-32V	100	± 1/2%	208/230V* 3 phase	1%
MR2432-200	24-32 V	200	± 1/2%	208/230V* 3 phase	1%
MR2432-300	24-32 V	300	± 1/2%	208/230V* 3 phase	1%
MR2432-500	24-32 V	500	± 1/2%	208/230V* 3 phase	1%

\* ± 10%. Also available in 460 V ± 10% AC input. Will be supplied with 230 V input unless otherwise specified.

**6, 12, 115 Volt Models**

Model	Volts	Amps	Reg.	AC Input (60 cps)	Ripple rms
6 Volt	6	5	± 1%	95-130 V 1 phase	1%
	6-5WX ± 10%				
	6-15WX ± 10%				
12 Volt	12	15	± 1%	95-130 V 1 phase	1%
	12-15WX ± 10%				
115 Volt	115	5	± 1/2%	95-130 V 1 phase	1%
	115-5WX ± 10%				
	MR15125-5				
G125-25**	115-125	25	± 1 1/2-4%	230/460 V 3 phase	5%

\*\*Germanium Rectifier Unit ††Increases to 4% @ 15V.  
 †Increases to 2% @ 15V.



cate adequate bandwidth. It is expected to have a much lower noise level than conventional microwave amplifiers making it applicable to the fields of radio astronomy, microwave relaying and radar.



**COMPLETELY** transistorized low-power computer programs logical data when . . .

## Computer Checks Computer Design

SOME 9,000 solid state devices make possible a new easy-to-maintain general-purpose digital computer about the size of a television console.

Developed for the Air Force by Bell Telephone Laboratories, the computer, named Leprechaun, will be used for programming and logical design research on computers for military use.

About 5,000 transistors, no tubes, are used. Circuits are so simple that Leprechaun may be adapted for a variety of jobs; complexity is in the wiring rather than in the changeable components.

Leprechaun is a pure binary computer using an 18-bit word. Arithmetic operations are asynchronous, in parallel, at average speeds of 25,000 additions or 2,500 multiplications a second.

The computer uses direct-coupled transistor circuits, and a 1,024-word magnetic core memory.

## World Radio Sets Gain 20%

Total estimated at 130,498,400 excluding U. S. and Canada, up 20% since 1954

RADIO receivers in all countries except the U.S. and Canada are estimated at 130,498,400 by the U.S. Information Agency.

This is a 20-percent increase over the estimate made from a similar survey in July 1954.

Here's how the total breaks down by areas: Western Europe—64,737,100, Eastern Europe—16,600,000, Yugoslavia—600,000, Arabic countries—2,141,500, Non-Arabic Asia—4,295,600, Non-Arabic Africa—1,158,100, Far East—19,488,000, Latin America—21,478,100.

► **Leaders**—Top five in Western Europe are: West Germany (including West Berlin)—14,475,000; United Kingdom—14,157,000; France—10,205,000; Italy—7 million; and Spain—3 million.

USSR leads Eastern Europe

with 6,100,000; East Germany—3,400,000; Czechoslovakia—2,916,000; Poland—2,034,000; Hungary—1,250,000.

Egypt leads the Arab countries of the Near East with 716,000; the territory comprising the former French Moroccan zone—335,000; Algeria—312,000; Syria—250,000; Iraq—125,000.

Turkey leads non-Arabic Asia with 1,198,400; India—1,129,000; Iran—590,000; Greece—500,000; Israel and Pakistan—each 335,000.

► **East**—Japan tops the Far East with 13,250,000; Australia—2,100,000; Communist China—1,100,000; Indonesia—650,000; New Zealand—517,000.

Brazil is first in Latin America with 6,000,000; Argentina—5,500,000; Mexico—3,200,000; Colombia—1,800,000; Cuba—1,250,000.

Union of South Africa leads non-Arabic Africa—815,000; Madagascar—60,000; French Equatorial Africa—50,000.



**SUBWAY** gate crashers are spotted on tv screen as . . .

## Closed Circuit Tv Guards Turnstiles

NEW YORK CITY'S Transit Authority is considering installing closed-circuit television guards in its subway stations.

A tv system was recently placed in the busy 42nd Street and Eighth Avenue station, near Times Square, by General Precision Laboratories.

► **Prospects**—It was removed after a trial period, but an Authority spokesman says he expects closed tv will be used again in the future.

How many stations would be equipped and at what cost is not known. The city has almost 500 subway stations. The value of the trial installation was \$3,000.

► **No freeloaders**—The camera was trained on an exit gate and connected by coaxial cable to a change booth 175 feet away.

The object was to spot riders attempting to enter the gates without a city employee's pass. Usual procedure is to station policemen at gates during rush hours.

The authority is also considering

(Continued on page 28)



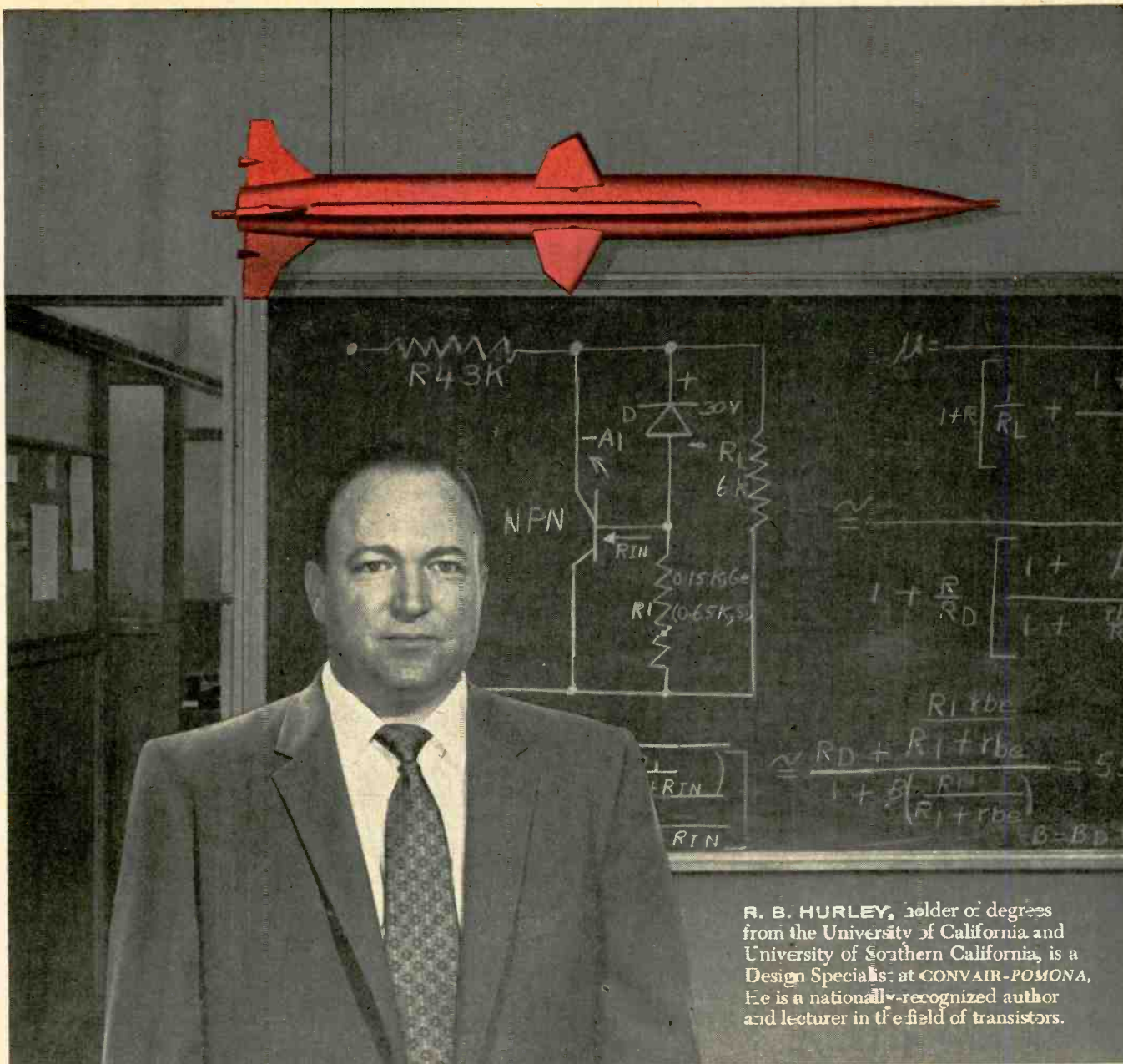

R. B. HURLEY, holder of degrees from the University of California and University of Southern California, is a Design Specialist at CONVAIR-POMONA. He is a nationally-recognized author and lecturer in the field of transistors.

## “Engineers—here’s how we’re taking part in the electronics revolution toward solid state devices”

“Here at CONVAIR-POMONA, we are constantly studying ways to apply the new miniature solid state electronic devices: the diode, rectifier and transistor. So new is this semiconductor infant, and so vast its future—both for the military and industry—that our teams of electronics engineers actually ‘go to school’ under some of the foremost experts in the field.

“As the *first* fully-integrated missile plant in the U.S., CONVAIR-POMONA designs and builds the Navy’s TERRIER supersonic missile. And, realizing the potential value of solid state devices in meeting the critical requirements of such airborne missiles, we initiated a ‘transistor program’ early in 1953. This program has multiplied many times to become one of the most important in the industry.

“You, as an engineer, can appreciate the tremendous expansion that will come in the application of solid state

electronic devices in the next few years. And you can readily understand the advantages of studying and working with these devices, guided by the advanced thinking you will find at CONVAIR-POMONA.

“You’ll like the atmosphere here, where you see and feel accomplishment. And you will enjoy living in Southern California’s beautiful Pomona valley. For greater career opportunity—*for your future’s sake*—send for more information about CONVAIR-POMONA *today!* Write to: Engineering Personnel, Dept. 3-G.”

# CONVAIR

POMONA

POMONA • CALIFORNIA

CONVAIR IS A DIVISION OF GENERAL DYNAMICS CORPORATION

closed-circuit tv to monitor station platforms, particularly at night and in little used stations, as a deterrent to crime.

## Financial Roundup

NINE out of eleven firms which reported earnings last month showed higher net profits in 1957 over comparable 1956 periods.

Annual earnings of Ampex Corp. set a new high in the firm's history.

Greatest net profit growth was registered by Topp Industries whose net profits this year were more than five times that of 1956.

Company	Net Profit	
	1957	1956
American Cable & Radio 3m	\$291,745	\$318,977
Ampex Corp. 12m	1,087,000	311,000
Avco Manufacturing 6m	5,232,621	28,716
Barry Controls 5m	107,000	76,000
Consol Electronics Ind 6m	1,154,803	1,174,441
Daystrom 12m	2,459,000	1,784,000
Dynamics Corp. Am. 3m	308,003	307,322
IT&T 3m	5,900,448	5,514,548
Litton Industries 9m	1,271,000	687,000
Sperry Rand 12m	49,612,352	46,348,878
Topp Industries 12m	466,796	92,062

## Gaseous Diffusion Aids Transistors

High frequency characteristics expected to extend transistor markets

TRANSISTORS, produced by gaseous diffused-junction process, are breaking out of testing and development and into volume production.

► **Last month**, Texas Instruments announced commercial availability of its new diffused silicon diode rectifier. One of T. I.'s major 1957 highlights is the introduction of its new diffused process silicon transistor.

► **By year end** Motorola expects to be producing diffused germanium and silicon transistors in quantity.

Western Electric is manufacturing gaseous diffused transistors for military applications, expects to make extensive use of them in telephone communications.

The gaseous diffused-junction transistor was developed about a

## Meetings Ahead

**Aug. 20-23:** 1957 Western Electronic Show and Convention, IRE, WCEMA, Cow Palace, San Francisco, Calif.

**Aug. 22-Sept. 5:** International Scientific Radio Union, Twelfth General Assembly, Boulder, Colo.

**Aug. 26-Sept. 4:** American Radio Relay League, National Convention, Palmer House, Chicago.

**Aug. 28-Sept. 7:** National Radio and Television Exhibition, Earls Court, London.

**Sept. 4-6:** Special Tech. Conference On Magnetic Amplifiers, Penn Sheraton Hotel, IRE, AIEE, Pittsburgh, Pa.

**Sept. 9-13:** Twelfth Annual Conference Instrument-Automation Conference, Cleveland Auditorium, Cleveland, Ohio.

**Sept. 17-18:** National Technical Meeting on Machine Tool Automation, RETMA, AIA, NEMA, NMTBA, Ambassador Hotel, Los Angeles, Calif.

**Sept. 24-25:** Sixth Annual Conference On Industrial Electronics, IRE, AIEE, Morrison Hotel, Chicago, Ill.

**Oct. 7-9:** National Electronics Conference, IRE, AIEE, RETMA, SMPTE, Hotel Sherman, Chicago.

**Oct. 7-11:** American Institute of Electrical Engineers, Fall general meeting, Chicago, Ill.

**Oct. 9-11:** Fourth Annual Symposium on High Vacuum

Technology, Committee On Vacuum Techniques, Hotel Somerset, Boston, Mass.

**Oct. 9-12:** Audio Engineering Society, 1957 Convention, N. Y. Trade Show Building, N. Y. C.

**Oct. 16-18:** IRE Canadian convention Automotive Building, Exhibition Park, Toronto, Canada.

**Oct. 21-26:** Institution of Radio Engineers Australia, annual convention, IRE, Hotel Australia, Sydney, Australia.

**Oct. 21-26:** International Conference on Ultra High Frequency Circuits and Antennas, Societe Des Radioelectriciens, Paris, France.

**Oct. 31-Nov. 1:** Professional Group on Nuclear Science, fourth annual meeting, Henry Hudson Hotel, New York, N. Y.

**Oct. 31-Nov. 1:** 1957 Electron Devices Meeting, PGED, Shoreham Hotel, Washington, D. C.

**Nov. 2-10:** 1957 International Congress of Measuring Instrumentation and Automation, Interkama, Dusseldorf, Germany.

**Nov. 4-6:** Third Annual Symposium on Aeronautical Communications, PGCS, Hotel Utica, Utica, N. Y.

**Nov. 11-13:** Third Instrument Conference, IRE, PGI, Biltmore Hotel, Atlanta, Ga.

year ago by Bell Telephone Labs. Since then the process has been made available to more than 50 Bell licensees.

High-frequency characteristics result from microscopically thin transistor sandwich layers produced in the process.

## Industry Shorts

► **Ultrasonic drill**, developed by Lockheed, will bore holes as small as five thousandths of an inch in miniature ferrite cores that are impervious to steel drills.

► **Propaganda** expenditures of

Russia and Communist China are variously estimated at from \$1 to \$3 billion annually, roughly 10 to 30 times the amount the United States spends on its program of truth. It is estimated that the Russians alone spend more money to jam our Voice of America broadcasts than we spend on the whole U. S. Information Agency budget.

► **Signals** broadcast by the National Bureau of Standards station at Fort Belvoir, Va., each day at 1600 UT alert IGY scientists throughout the world to coordinate solar-terrestrial observations simultaneously.



**SWEEPING  
OSCILLATORS  
for RADAR and  
TELEMETERING IF's 1-1,200 mc  
by**

**KAY ELECTRIC**

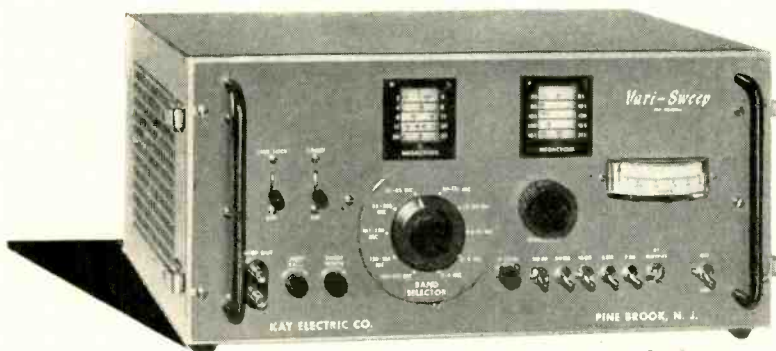

Kay *Vari-Sweep* 860-A

The Kay sweeping oscillators are a line of high level lab and field test instruments designed for the alignment of radar and telemetering IF strips from 1 to 1,200 mc. The line offers a wide choice of precision-built units which are simple to operate, highly stable, and extremely flexible.

- Wide Range, Wide Sweep
- High Output
- Fundamental Frequency
- Constant Output (Fast-Acting AGC)
- Continuously Variable Centers
- Fixed, Crystal-Controlled Markers
- All Electronic Operation

Instrument	Cat. No.	Range	Sweep Width	RF Output	Markers	Price†
<i>Vari-Sweep</i>	860-A	2-220 mc (center)	Contin. Variable to 60% center freq. below 50 mc; 30 mc plus, above 50 mc.	1.0 V rms AGC'd, 70 ohms	None	\$695.
<i>Vari-Sweep</i> Model IF	866*	4-120 mc (center)		1.0 V rms AGC'd, 70 ohms	11 Fixed Crystals 1 Variable. Direct reading dial	\$950.
<i>Vari-Sweep</i> Model Radar	865*	10-145 mc (center)		1.0 V rms AGC'd, 70 ohms	11 Fixed Crystals 1 Variable. Direct reading dial	\$950.
<i>Mega-Sweep</i>	110-A**	50 kc-950 mc	50 kc-40 mc	100 mv at 50 ohms	None	\$495.
<i>Rada-Sweep</i>	380-A*	2 Switched bands 20-40 mc; 50-70 mc	2 Switched bands, Wide 20 mc, Nar. 3 mc	250 mv rms, 70 ohms	9 Fixed Crystals	\$395. (with 4 crystals)
<i>Rada-Sweep Sr.</i>	385*	1-260 (center)	70% of center to 100 mc; 60-70 mc from 100-250 mc	0.5 V rms AGC'd, 70 ohms	Up to 24 Fixed Crystals	\$545. (plus crystals)

\*\*Other Mega-Sweeps to 1200 mc; and with Markers.

\*Wider sweep widths, additional crystal markers available on special order.

† All prices F.O.B. Pine Brook, N. J.

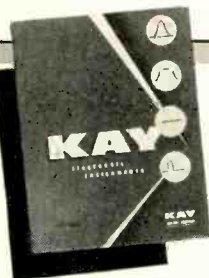

For Literature and Detailed Specifications, Write:

**KAY ELECTRIC COMPANY**

14 Maple Avenue, Pine Brook, N. J.  
Dept. E-8 CALdwell 6-4000

**MARCONI**  
**MILITARY AND CIVIL**  
**airborne**  
**DOPPLER**  
**NAVIGATORS**

**CONTINUOUS AUTOMATIC POSITION  
INDICATION WITHOUT GROUND-BASED  
AIDS, ALL OVER THE WORLD**

POSITION IN LATITUDE AND LONGITUDE  
DISTANCE RUN AND DISTANCE TO GO • WIND VELOCITY  
ESTIMATED TIME OF ARRIVAL • TRACK GUIDANCE

*Write for details to*

**AERONAUTICAL DIVISION**

J. S. V. WALTON, MARCONI'S WIRELESS TELEGRAPH COMPANY LIMITED  
23-25 BEAVER STREET, NEW YORK CITY 4.

MARCONI'S WIRELESS TELEGRAPH COMPANY LIMITED, CHELMSFORD, ENGLAND



# The Lifeline of communication . . .

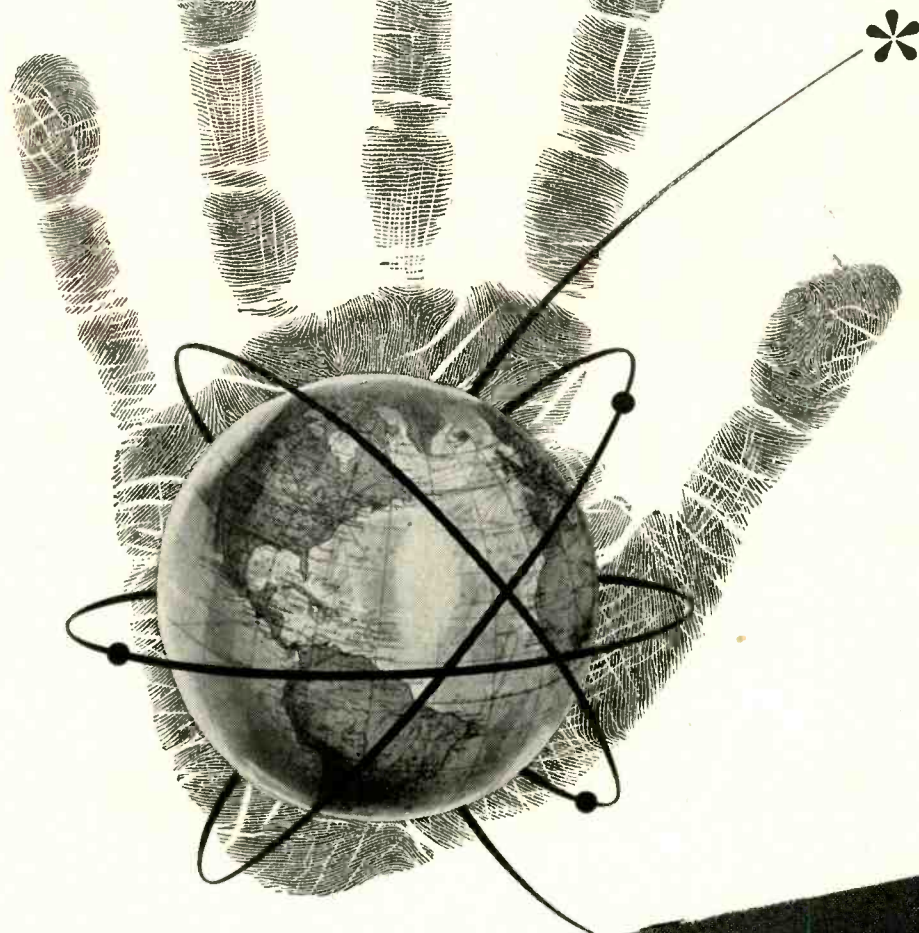

More than eighty countries use Marconi telecommunications equipment. The total telephone channel miles of Marconi radio multi-channel systems would go 15 times round the world.

Marconi's have supplied broadcasting or television equipment to eighty countries. Most of the equipment used by the British Broadcasting Corporation and the British Independent Television Authority and its programme contractors is Marconi's. Marconi's demonstrated 'compatible' colour television in 1954.

Thirty-two airforces rely on Marconi radio, radio navigational aids and radar. For the past two years Marconi's have been in quantity production with Doppler Navigators for British and Commonwealth governments. Many of the world's major airports use Marconi radio communications, beacons and radar.

All the radio beacons round the coasts of the British Isles and Eire and many in other major seaways have been supplied by Marconi's.

These few statements give some idea of the manufacturing achievement of Marconi's, who also maintain larger research facilities devoted to radio electronics than any other European company. Moreover Marconi College was the world's first school for wireless engineers. Courses there are the coveted privilege of the world's most promising radio engineers.

*The inquiries of radio and electronic engineers who wish to keep themselves posted about the latest Marconi equipment and activities are most welcome. Write to:*  
**J. S. V. WALTON, MARCONI'S WIRELESS TELEGRAPH COMPANY, LIMITED,**  
23-25 Beaver Street, New York City 4.

**MARCONI'S WIRELESS TELEGRAPH COMPANY, LIMITED, CHELMSFORD, ESSEX, ENGLAND**

## MARCONI

**SYSTEM PLANNERS,  
ELECTRONIC ENGINEERS,  
DESIGNERS AND MANUFACTURERS  
OF AERONAUTICAL, BROADCASTING,  
COMMUNICATION AND MARITIME  
RADIO EQUIPMENT,  
TELEVISION EQUIPMENT,  
RADAR AND NAVIGATIONAL AIDS**

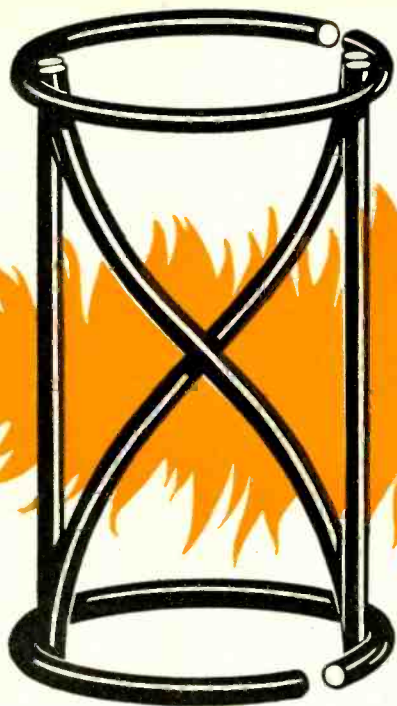

## **MORE HOURS OF HEAT ENDURANCE FROM VINYL-GLASS SLEEVING**

# **BH VINYL-SIL**

**. . . retains rated dielectric and flexibility  
after 2800 continuous hours at 130°C**

Today's insistence on insulation with high heat endurance — higher processing temperatures, wire enamel compatibility, hotter operation — has emphasized the importance of BH Vinyl-Sil.

Available in two types — BH Vinyl-Sil 8000 and BH Vinyl-Sil 105 — both with 8000 volt minimum dielectric breakdown, and meeting all requirements of ASTM, NEMA\* and MIL-I-3190B\* Class B-A-1 specifications. BH Vinyl-Sil 105 offers no capillary attraction to water and is the first vinyl sleeving to be Underwriters' Laboratories recognized for 600 volt, continuous wet or dry operations at 105°C.

BH Vinyl-Sil Sleeveings are specially fabricated of braided glass fibers, then continuously coated by a patented process with a uniquely stabilized vinyl chloride compound. High standards of manufacturing developed in over seven years pioneering experience with vinyl-glass sleeveings is your assurance of reliable operational performance.

Data sheets and testing samples are yours for the asking — just write, giving a few facts about the insulation problems to be encountered — we'll make recommendations and send you appropriate samples.

**BENTLEY, HARRIS**

*Flexible\**  
**SLEEVINGS**

BENTLEY, HARRIS MANUFACTURING COMPANY  
1308 Barclay Street

CONSHOHOCKEN PA. • TELEPHONE: TAYLOR 8-0634

\*New Revised Standards Available on Request.



# OHMITE®

the complete

line of

industry-preferred **COMPONENTS**

Long life and dependability are synonymous with the name Ohmite. When you specify Ohmite components . . . you build reliability into your product. This reliability is backed by Ohmite's continuing research programs which explore new product ideas, improve present products, and develop more efficient manufacturing processes. All this plus the fact that Ohmite is the world's leading specialist in the manufacture of power-type resistance components —high quality rheostats and wire-wound resistors in the most complete range of sizes and types available to industry. Reliability is also characteristic of Ohmite tap switches, precision wire-wound resistors, molded composition resistors and potentiometers, general-purpose relays, subminiature tantalum capacitors, and R. F. chokes. Write on company letterhead for the complete Ohmite Catalog and Engineering Manual.

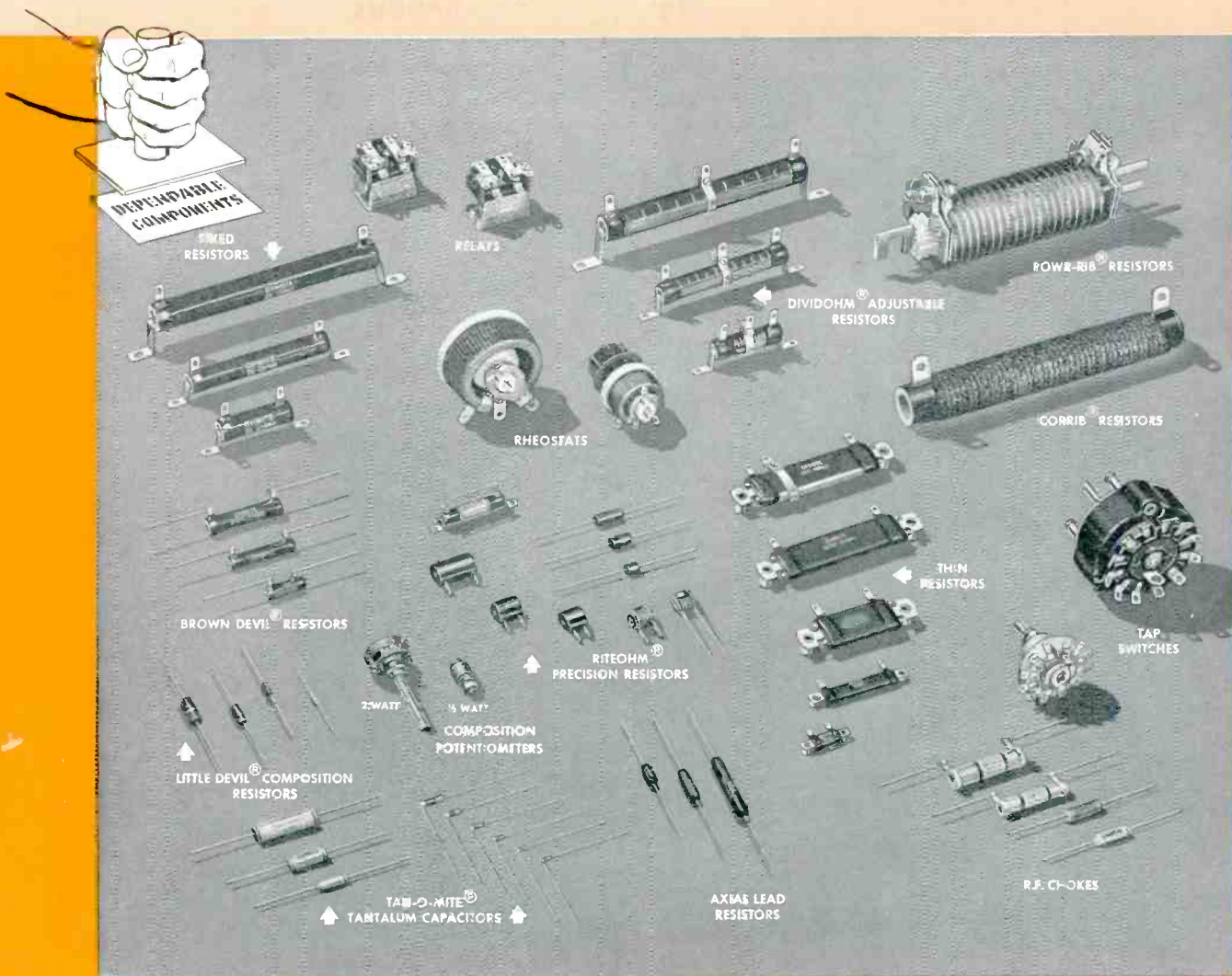

**BE RIGHT WITH**

# OHMITE®

**RHEOSTATS • RESISTORS • RELAYS • TAP SWITCHES • TANTALUM CAPACITORS**

OHMITE MANUFACTURING COMPANY • 3610 Howard Street, Skokie, Illinois

solve many difficult control problems...use

OHMITE®

**RHEOSTATS**

with special features

Ohmite offers not only a line of *standard* rheostats but also rheostats with a wide variety of *special features*. Illustrated are only a few. All have the distinctive Ohmite design features: smoothly gliding metal-graphite brush; all-ceramic construction; insulated shaft and mounting; windings permanently locked in place by vitreous enamel. You will find the special rheostat feature you need in the dependable Ohmite line.

**SPECIAL TANDEM ASSEMBLIES**

Ohmite Rheostats can be mounted with two, three, or more in tandem for simultaneous operation of several circuits by one knob.

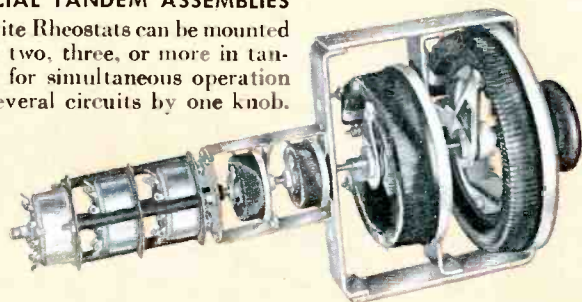

**BUSHINGS FOR SPECIAL THICKNESS**

Extra-long bushings and shafts for panels up to 2" in thickness. Seven bushing lengths.



**SCREW DRIVER SLOT SHAFT**

Shaft ends slotted for operation with a screw driver where few adjustments are needed.



**VENTILATED CAGES**

Prevents mechanical injury to rheostat or human contact with electrically "live" parts.



**SENSITIVE SWITCH**

Opens or closes circuit with minimum movement of control knob shaft. Extremely dependable long life switches.



**TOGGLE SWITCH**

Is operated with a positive snap by the rheostat arm at either end position. Used for heavy-duty applications.



**WITH OFF POSITION FEATURES**

Opens circuit at high or low resistance position with *snap-action* (illus.); opens circuit at high resistance position with *dead lug off position*; or has *dead section off position*.

**INDUSTRY'S MOST COMPLETE LINE OF RHEOSTATS**

from 25 to 1000 watts. Also available to meet MIL-R-22A requirements in each of the 26 type designations.

WRITE on Company Letterhead for Catalog and Engineering Manual.

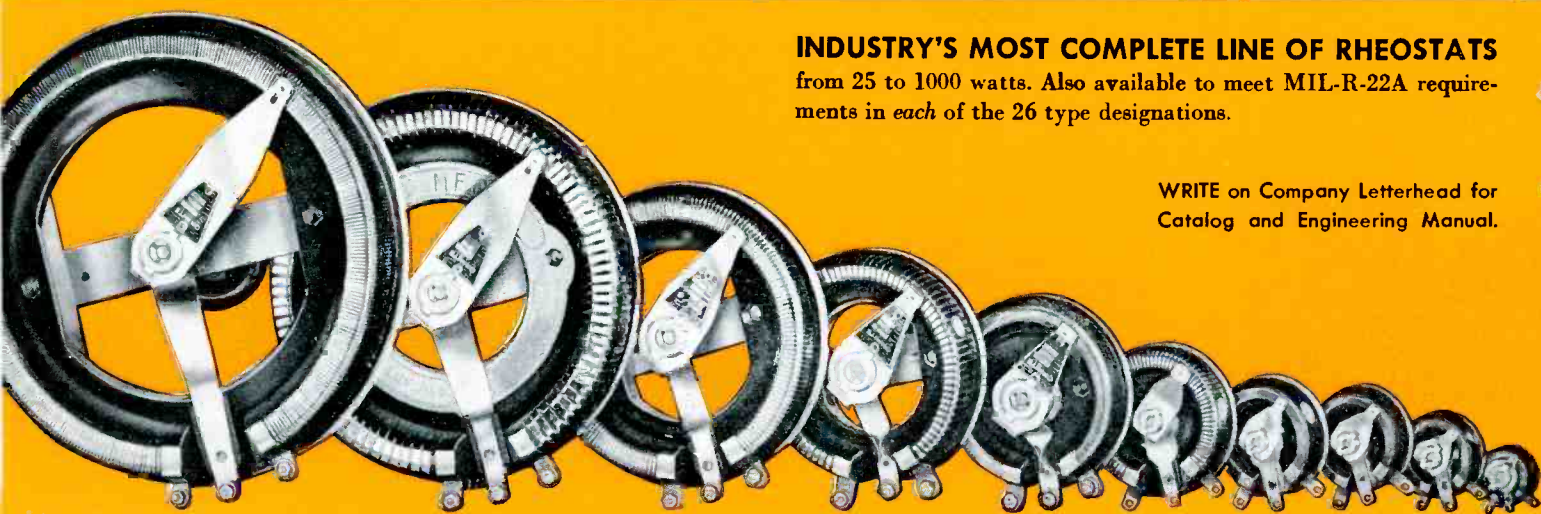

RHEOSTATS • RESISTORS • RELAYS  
TAP SWITCHES • TANTALUM CAPACITORS

OHMITE®

OHMITE MANUFACTURING COMPANY, 3610 Howard Street, Skokie, Illinois



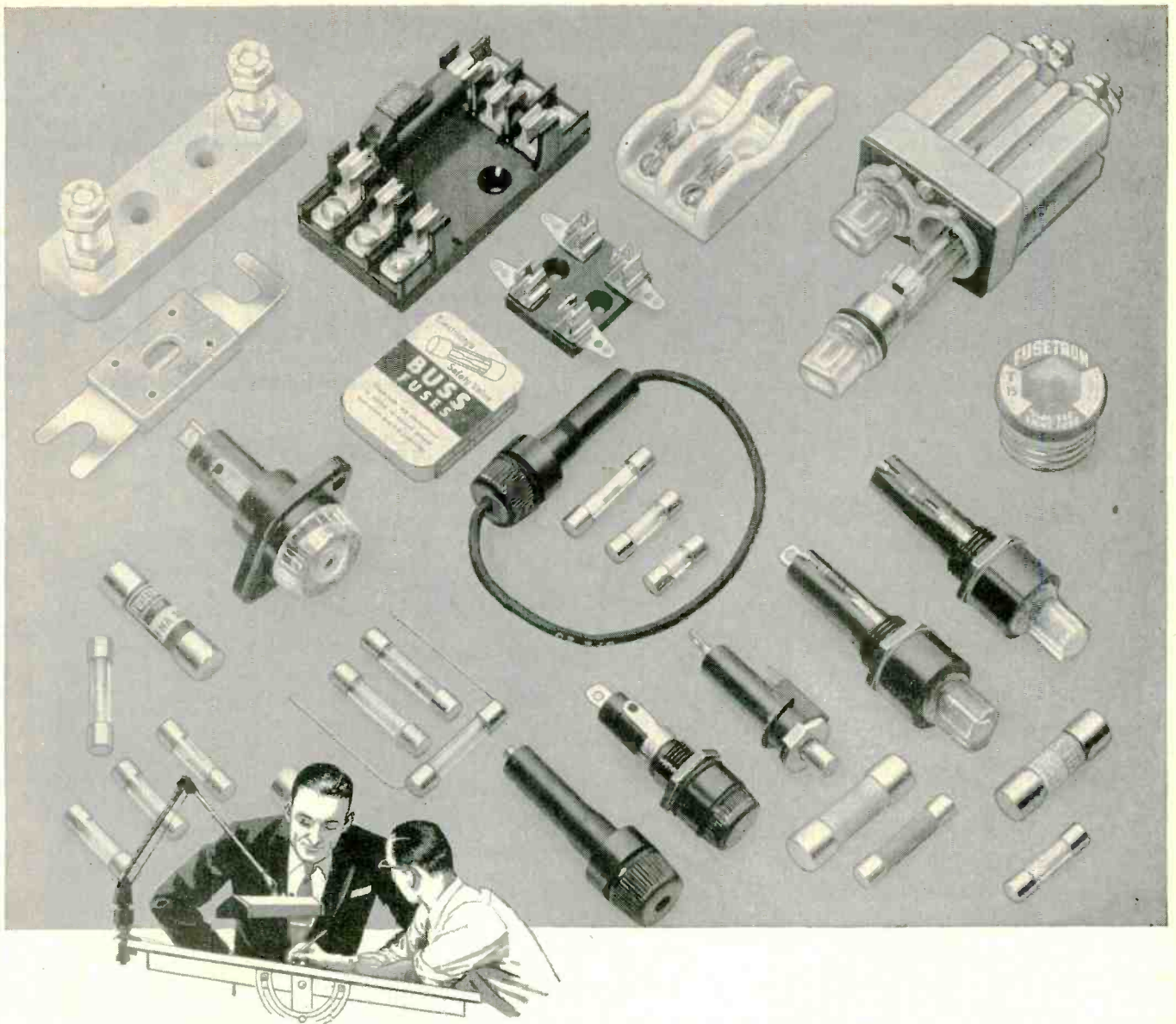

## For Safe, Dependable Electrical Protection . . . Standardize on BUSS Fuses!

To make sure of proper operation under all service conditions . . . every BUSS fuse is tested in a sensitive electronic device that automatically rejects any fuse not correctly calibrated, properly constructed and right in all physical dimensions.

This careful testing is your assurance BUSS fuses will provide equipment with maximum protection against damage due to electrical faults.

Just as important, BUSS fuses will not give a false alarm by blowing need-

lessly. Shutdowns due to faulty fuses blowing without cause are eliminated.

By specifying dependable BUSS fuses, you help safeguard the good name of your equipment for quality and reliability.

*Complete Line*—There is a complete line of BUSS fuses in sizes from 1/500 ampere up . . . plus a companion line of fuse clips, blocks and holders.

**If your protection problem is unusual . . .**

. . . let the BUSS fuse engineers work

with you and save you engineering time. If possible, they will suggest a fuse already available in local wholesalers' stock, so that your device can be easily serviced.

For more information on BUSS and FUSETRON Small Dimension fuses and fuseholders . . . Write for bulletin SFB. Bussmann Mfg. Division (McGraw-Edison Co.) University at Jefferson, St. Louis 7, Mo.

*BUSS fuses are made to protect—not to blow, needlessly*

357



Makers of a complete line of fuses for home, farm, commercial, electronic, automotive and industrial use.

AEROCOM'S 1046 H. F. TRANSMITTER

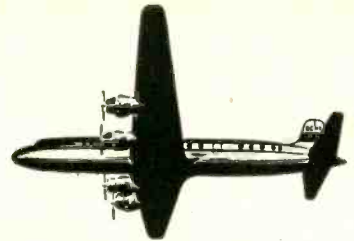

# POWER + STABILITY

1000 WATTS

WITH

.003% STABILITY

Rugged, versatile general purpose H. F. transmitter—Aerocom's 1046 packs 1000 watts of power and high .003% stability under normal operating conditions (0° to +50°C.). Excellent for point-to-point or ground-to-air communications.

Multi-channel operation on telegraph A1, or telephone A3 with GM-8A modulator... new Aerocom 1046 can be *remotely controlled* with TMC-R at control position and uses only one pair of telephone lines. In A3 operation, the local dial control panel is located in modulator cabinet.

Transmitter cabinet has 8¾ inch panel space available for either local dial control panel or frequency shift keyer.

Model 1046 operates on 4 crystal-controlled frequencies (plus 2 closely spaced frequencies) in the band 2.0—24 Mcs. Operates on one frequency at a time; channeling time 2 seconds. Operates into either balanced or unbalanced loads. Operates in ambient -35° to +50° C. Power supply: nominal 220 volts, 50-60 cycles, single phase.

*Complete technical data on request*

Now! Complete-package, 192 channel, H. F., 75 pound airborne communications equipment by Aer-O-Com! Write us today for details!

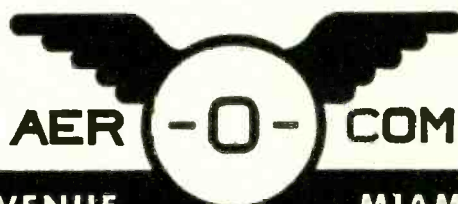
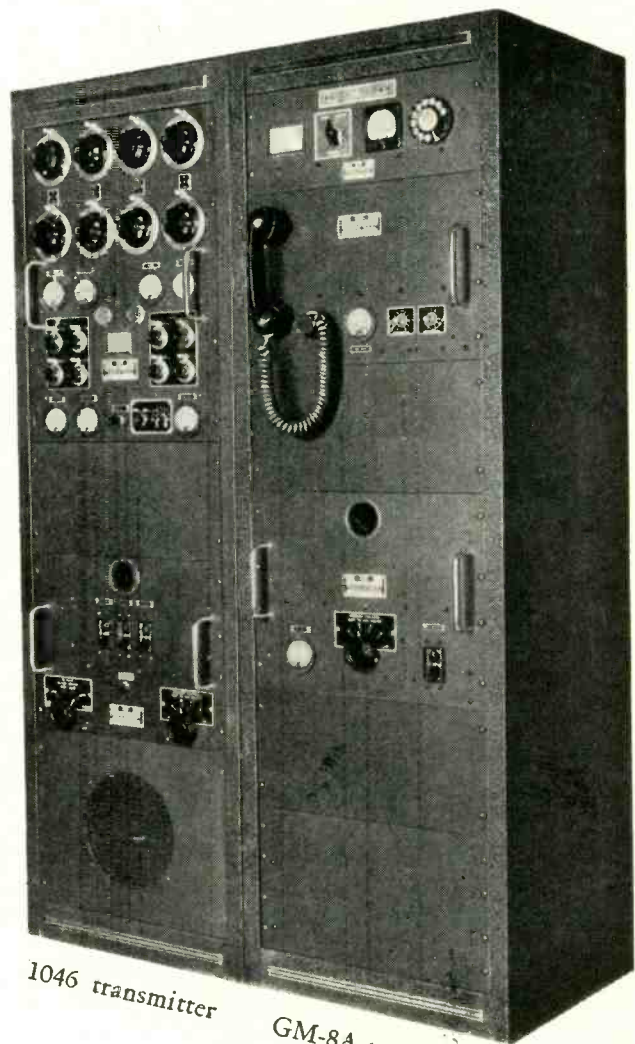

3090 S. W. 37th AVENUE

MIAMI 33, FLORIDA



# HERMETIC SEAL CORPORATION

## AFFILIATES & DIVISIONS

*Ready* **TO SERVE ALL YOUR GLASS-TO-METAL NEEDS!**



**Quality Hermetics, Ltd.**  
45 Hollinger Rd., Toronto 16, Ont.  
PLYmouth 7-2869



**Hermetic Seal Corporation**  
29 S. Sixth St., Newark 7, N. J.  
MARket 3-9400

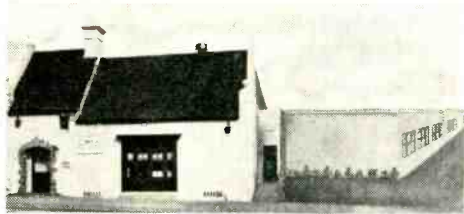

**Glass-Solder Engineering**  
300 N Lake Ave., Pasadena 4, Calif.  
RYan 1-5111



**Hermetic, Inc.**  
232 Creek Rd., Keansburg, N. J.  
KEansburg 6-2600



**Hermetic Seal Products Co. P.R.**  
Rio Piedras, Puerto Rico  
Rio Piedras 6-3615



**Hermetic Engineering Service Co., Inc.**  
Complete Hermetic Seal Consulting Services  
and Technical Assistance.

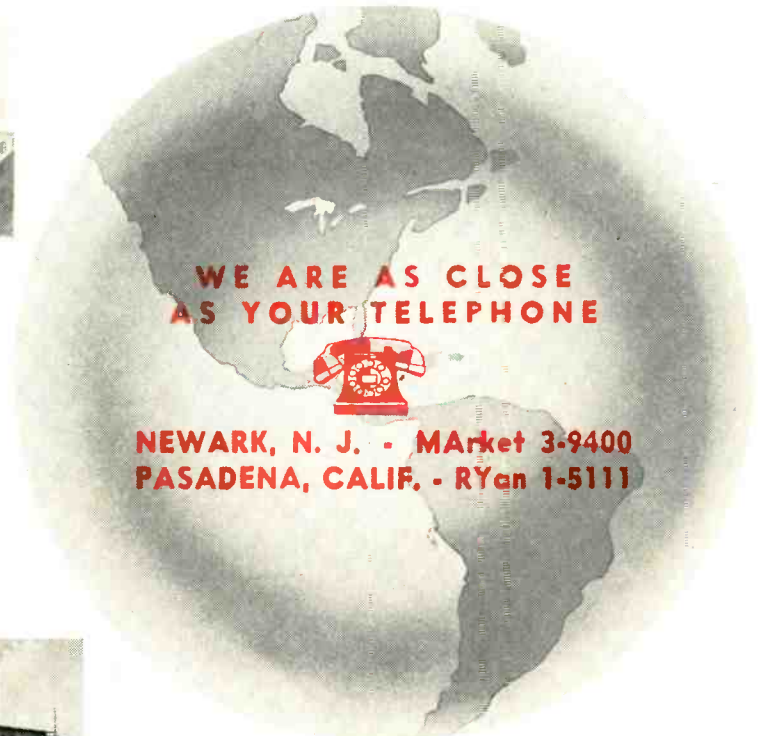

**WE ARE AS CLOSE  
AS YOUR TELEPHONE**

**NEWARK, N. J. - MARket 3-9400  
PASADENA, CALIF. - RYan 1-5111**

The expanding research, development and production facilities of HERMETIC SEAL CORPORATION — *first and foremost in the production of glass-to-metal components* — are available to meet *all* your standard and custom requirements. Write for Catalog 657-B today.

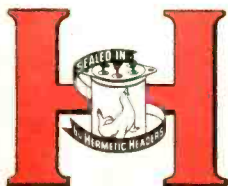

**Visit Our Booth No. 2112, WESCON SHOW — Aug. 20-23**  
**HERMETIC SEAL CORPORATION**

29 SOUTH SIXTH STREET, NEWARK 7, NEW JERSEY



FILTRON'S mobile shielded laboratory and the Convair F-102, the Air Force's new supersonic delta-winged Fighter.

## r-f mobile laboratory uses ACE enclosure for on the spot tests

Measurements of radio interference from aircraft once was a real problem. FILTRON Company, Inc., manufacturers and designers of r-f filters and suppression systems, realizing that aircraft could not get to a shielded lab, took the problem to Ace. Together, they developed the Mobile Radio Interference Laboratory pictured above. It's a completely equipped r-f lab shielded on all sides by a standard Ace RFI Design\* En-

\*Lindsay Structure

closure. The prefabricated galvanized steel panels and frames mount directly on a flat-bed Chevrolet truck. Accessories include air conditioning and power generators to operate all necessary equipment.

FILTRON'S lab on wheels has traveled many thousands of miles, a lot of it over rough bumpy roads. The Ace enclosure is still completely "radio-tight" supplying more than its guaranteed 100

db attenuation at all frequencies from 14 kc to 1000 mc.

This mobile lab is one of many unique Ace applications. Our complete line of screen and sheet, copper and galvanized enclosures probably includes the solution to your shielding problems—whether you're in military, industrial, or medical work. An Ace sales engineer would be glad to show you how. Our catalog is a good start. Write for your free copy.



First and Finest in Shielded Enclosures

ACE ENGINEERING & MACHINE CO., INC. 3644 N. Lawrence St. • Phila. 40, Pa.



★ **AIRCRAFT PUMPS**

Precision-built to rigid government specifications, a broad selection among Eastern pumps offers flexibility to your choice. Modifications can be made, or custom-made units designed to suit your project. Trim in size, light in weight, Eastern Aircraft Pumps give reliable long-term service.



★ **PRESSURIZATION**

Eastern pressurization units for airborne electronic equipment are available in many capacities to handle a broad range of requirements. Units consist of an air pump and motor assembly, pressure switch, check valve, tank valve, and terminal connectors. They meet government specifications and can be modified to your needs.



eliminate the "BUGS"

with Eastern aviation products

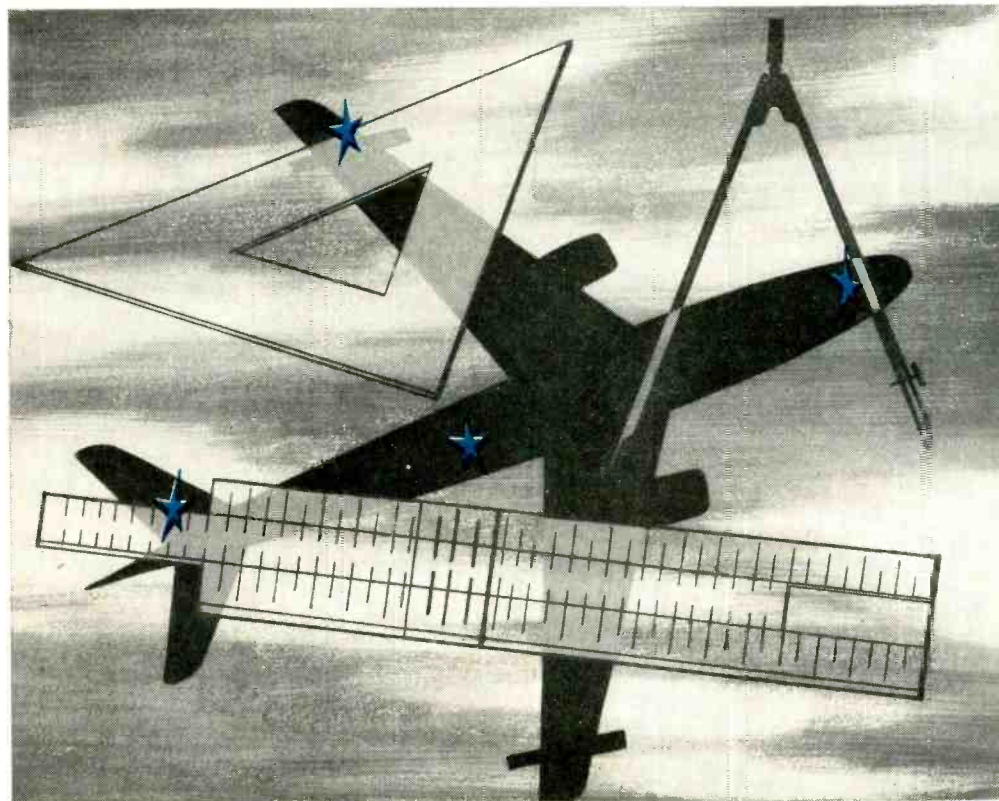
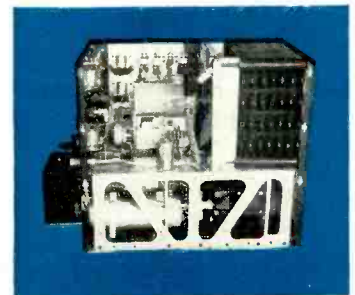
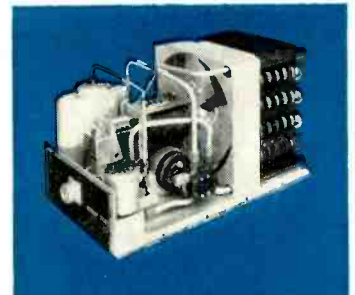

★ **COOLING UNITS**

Hold temperatures to safe operating limits in liquid cooled electronic tubes or similar devices. By virtue of long experience and using standard component parts, Eastern can suit your specific needs at a minimum cost for equipment.

★ **REFRIGERATION-TYPE**

Enable specified components to be held to fairly constant temperatures by use of various types of refrigeration units. Because of the variation in methods possible, Eastern units fill every requirement where the use of a refrigeration cycle is called for.

★ **SPECIAL UNITS**

Eastern's continual research and development program keeps pace with the growing aviation industry. As new problems occur with progress in aircraft development, Eastern units are constantly developed to fill their function as planes fly higher, or faster, or with greater load capacity.

Eastern welcomes the chance to help engineers "take out the bugs" with equipment that cools, pressurizes, or pumps. From the extensive line of existing units, new adaptations, or custom-made designs, Eastern is ready to meet every challenge for equipment that handles your needs *the best today . . . better tomorrow.*



See you at Wescon Show — Booth 3216  
Write for Aviation Products Catalog, Bulletin 330.

# Reliable, Efficient DC Conversion

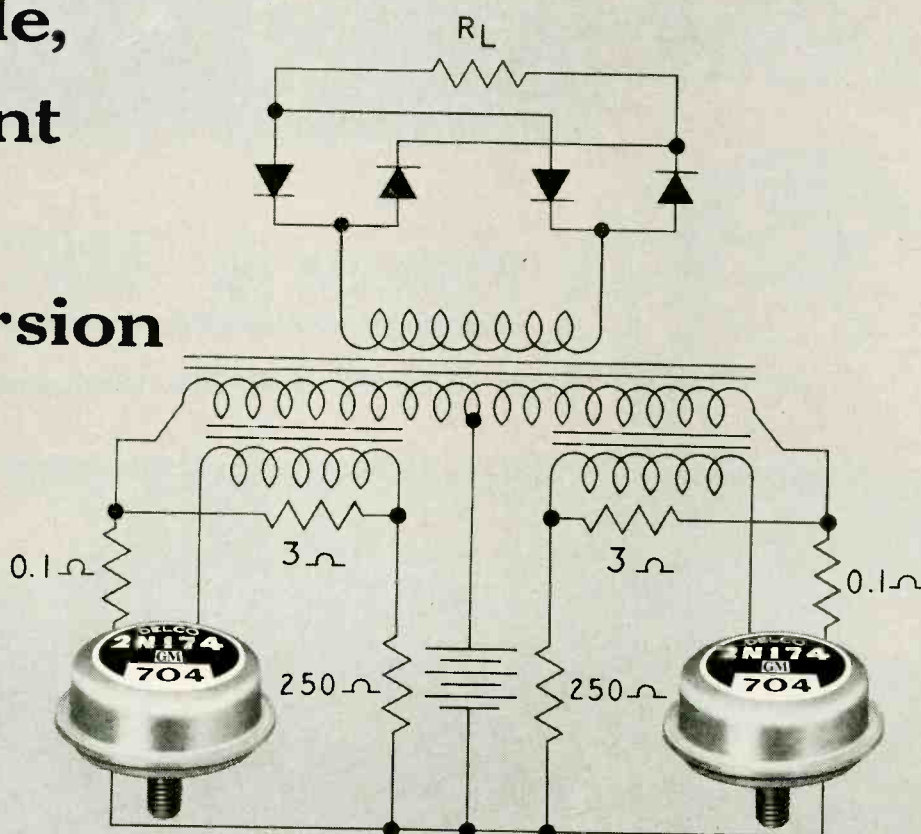

## Industry's Highest Power Transistors

*Low saturation voltage of Delco Radio 2N173 and 2N174 opens new opportunities for converter economy, efficiency and reliability*

The excellent electrical characteristics of Delco High Power transistors permit the conversion of *low* DC voltage to *higher* DC voltage—with a high degree of efficiency—in a wide range of applications. This proved performance offers greater reliability than will be found in corresponding vibrator circuits.

The low saturation voltage of Delco 2N173 and 2N174 transistors also reduces their internal power dissipation in conversion applications to an insignificant degree so that little self-heating is apparent. The result is an overall economy which permits converters of smaller size . . . important in many applications.

TYPICAL CHARACTERISTICS

	2N173	2N174
Properties (25°C)	12 Volts	28 Volts
Maximum current	12	12
Maximum collector voltage	60	80
Saturation voltage (12 amp.)	0.7	0.7
Power gain (Class A, 10 watts)	38	38
Alpha cutoff frequency	0.4	0.4
Power dissipation	55	55
Thermal gradient from junction to mounting base	1.2°	1.2°
Distortion (Class A, 10 watts)	5%	5%

**DELCO RADIO**

DIVISION OF GENERAL MOTORS  
KOKOMO, INDIANA



# PUSH-PUSH

# PULL-PUSH



One push on—  
One push off

**CTS**

Pull to turn on—  
Push to turn off

## Two new switch- controls Volume setting unaltered by ON-OFF operation

Just switch on and walk away. No coming back or waiting for further adjustment after warm-up.

Volume can be changed instantly as desired by rotating shaft . . . or can remain indefinitely at any selected setting regardless of on-off switch operations.

Push-push switch available with either 3 amp 125V rating (Type J) or 6 amp 125V rating (Type TJ).

Pull-push switch available with 3 amp 125V rating (Type K). Both switches available in many special terminal and control combinations.

Write today for Data Sheets containing dimensional drawings and complete technical details.

**WEST COAST SUBSIDIARY**  
Chicago Telephone of  
California, Inc.  
105 Pasadena Avenue  
South Pasadena, California  
L. A. Phone: CLinton 5-7186  
TWX LA 1105

**EAST COAST OFFICE**  
5 Haddon Avenue  
Haddonfield, New Jersey  
Phone: Haddonfield 9-5512  
TWX No. Haddonfield 529  
Phila. Phone: Market 7-3129

**SOUTH-WESTERN U.S.A.**  
John A. Green Company  
37 Parkhouse  
Dallas 7, Texas  
Phone: Riverside 3266

**CANADIAN SUBSIDIARY**  
C. C. Meredith & Co., Ltd.  
Streetsville, Ontario  
Phone 310

**SOUTH AMERICA**  
Jose Luis Pontel  
Buenos Aires, Argentina  
Montevideo, Uruguay  
Rio de Janeiro, Brazil  
Sao Paulo, Brazil

**OTHER EXPORT**  
Sylvan Ginsbury  
8 West 40th Street  
New York 18, New York  
Phone: Pennsylvania 6-8239

The most complete line of variable resistors and associated switches available is manufactured by CTS. Consult CTS Specialists on all your control problems.



**WEST COAST MANUFACTURERS:**

Many types of variable resistors now in production at our South Pasadena plant. Your coil, transformer and compression molding business also invited. Prompt delivery. Modern versatile equipment. L. A. phone CLinton 5-7186.

Blrton Browne Advertising

**CHICAGO TELEPHONE SUPPLY**  
*Corporation*

ELKHART • INDIANA

*The Exclusive Specialists in Precision Mass Production of Variable Resistors*

# A NEW STAR FOR ALL-WEATHER FIXES

## EDO AIRBORNE LORAN

Now, the long-awaited aircraft loran, designed primarily to fill the needs of transoceanic flying and packaged for cockpit installation, is announced by EDO. Built specifically to meet airline requirements, this new lightweight unit is designed for instrument panel mounting, convenient to the pilot.

It's no longer necessary to pay a heavy weight penalty for the added safety and convenience of loran gear. Edo's new set weighs only 26 pounds completely installed.

Built to the highest electronic standards, the Edo Model 345 gives quick, directly read time difference readings for accurate plots in a matter of seconds. No calculation, no computations, no tables, no special training needed to operate. As simple to use as any other pilot-operated radio navigation aid.

A development of Edo's years of research, design and production of dependable marine loran sets and other high performance electronic equipment, the Model 345 contains the latest miniaturized circuitry. Its compact remote control console and clear, easily read 3-inch scope fit neatly into the restricted space of an airplane instrument panel.

If you are interested in detailed specifications and operating data, please write for particulars.

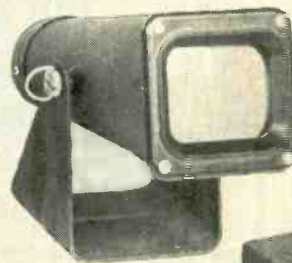

Model 345

For Cockpit  
Installation

26 Pounds  
Total Weight\*

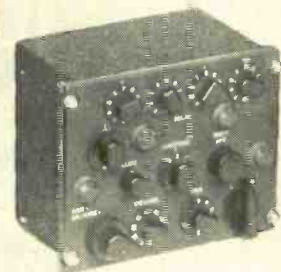

Compact scope and command control designed for cockpit installation. 34-tube receiver (not shown) occupies  $\frac{3}{4}$  ATR rack.

### FEATURES OF THE EDO MODEL 345

- 3-inch scope easily read even under bright light conditions. Does not require a special hood. Can be mounted directly in instrument panel, or other accessible spot.
- Pilot-operated command control gives directly read solution to problem. No calculations, no tables, no special training needed to operate.
- Loran receiver containing 34 tubes. Features low power consumption — only 175 watts, 115 v 400 cycles; 25 watts, 24 v DC.
- No-drift signal assured by special oscillator control.
- Highly accurate voltage regulation for dependable operation.
- Complete fail-safe feature.

BROCHURE AVAILABLE ON REQUEST

The



Corporation

College Point, Long Island, New York

Manufacturers of

a Trusted Line of Marine and Airborne Electronic Equipment



# MIL-AC Custom Air Conditioning



## Condition: Military Mobility

Mobile electronic systems can function under the most difficult environmental conditions (MIL-E-5272\*), by using highly specialized mobile air conditioning equipment.

Custom air conditioning is our business at Ellis and Watts. For example, we recently designed and built MIL-AC air conditioning equipment for trailer-mounted F-11-F operational flight trainer simulators. They develop 10 tons of cooling capacity at 130° F., using no water. These units are only 24" wide and can be mounted anywhere to suit specific space requirements. This equipment is designed for an unusual 3-zone air distribution system to maintain constant temperature and humidity in computer, instructor and trainee sections—each with a different varying load condition.

MIL-AC units are self-contained, compact, lightweight, readily air transportable. They can be designed to cool, heat, humidify, dehumidify, filter, and can incorporate air-cooled or water-cooled condensers. Units are manually or automatically controlled. We are staffed with specialists who will analyze your requirements, submit a proposal, complete your installation promptly and to your complete satisfaction.

Write for helpful load calculating Nomograph and other technical data for use in making time-saving preliminary calculations.

\*Military specification dealing with the following climatic and environmental conditions: Temperature, humidity, altitude, salt spray, vibration, fungus, sunshine, rain, sand and dust, explosive atmosphere, acceleration and shock.

*Typical MIL-AC Unit. MIL-AC configurations, features and functions to suit your specific requirements.*



## ELLIS AND WATTS PRODUCTS, INC.



*P.O. Box 33, Cincinnati 36, Ohio.*

*Ellis and Watts also design and build custom air conditioners, liquid coolers and heaters, dehumidifiers, wave guide dehumidifiers, laboratory temperature and humidity control units.*

for  
**HEARING  
AIDS**



or  
**RECORDING  
HEADS**



or ANY MAGNETIC MATERIALS JOB ...

Write for  
your Copy

**"MAGNETIC  
MATERIALS"**

This 32-page book contains valuable data on all Allegheny Ludlum magnetic materials, silicon steels and special electrical alloys. Illustrated in full color, includes essential information on properties, characteristics, applications, etc. Your copy gladly sent free.

**ADDRESS DEPT. E-92**

You can rely on core materials like the Allegheny 4750 components illustrated above, in your receivers, recording heads or microphone assemblies.

In fact, whether your equipment is small or large, the extra-broad line of A-L magnetic materials will solve your magnetic core problems. It includes all grades of silicon steel sheets or coil strip, as well as Allegheny Silectron (grain-oriented silicon steel), and a wide selection of high-permea-

bility alloys such as 4750, Mumetal, Permendur, etc.

Our service on these materials also includes complete facilities for the fabrication and heat treatment of laminations. (For users of electrical sheets and strip, our lamination know-how is a real bonus value!) Either way, we'll welcome the chance to serve you. *Allegheny Ludlum Steel Corporation, Oliver Building, Pittsburgh 22, Pa.*

**STEELMAKERS** to the Electrical Industry

**Allegheny Ludlum**

W&D 5335





**THEY'RE  
CHECKING VIDEO EVERYWHERE**

WITH THE  
FAMOUS

**TELECHROME**  
INCORPORATED



Model 1003-B

**PORTABLE VIDEO TRANSMISSION  
TEST SIGNAL GENERATOR**

★ Completely self contained ★ Portable ★ Multi-frequency burst ★ Stairstep ★ Modulated stairstep  
★ White window ★ Composite sync ★ Regulated power supply.

**DELIVERY 30 DAYS**

Literature on the above and more than 100 additional instruments for monochrome and color TV by TELECHROME are available on request.

The Nation's Leading Supplier of Color TV Equipment  
28 Ranick Drive Amityville, N. Y.  
Lincoln 1-3160

**TELECHROME**  
INCORPORATED



**MULTI-FREQUENCY BURST  
AMPLITUDE vs FREQUENCY.**

Check wide band coaxial cables, microwave links, individual units and complete TV systems for frequency response characteristics without point to point checking or sweep generator.



**WHITE WINDOW**

**LOW & HIGH FREQUENCY CHARACTERISTICS.** Determine ringing, smears, steps, low frequency tilt, phase shift, mismatched terminations, etc. in TV signals or systems.

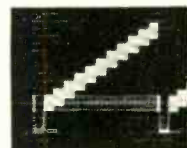

**STAIRSTEP SIGNAL** modulated by crystal controlled 3.579 mc for differential amplitude and differential phase measurement. Checks amplitude linearity, differential amplitude linearity and differential phase of any unit or system.

Model 1003-C includes variable duty cycle stairstep (10-90% average picture level).

Model 608-A HI-LO CROSS FILTER for Signal analysis.



**MODULATED STAIRSTEP** signal thru high pass filter. Checks differential amplitude.



**MODULATED STAIRSTEP** signal thru low pass filter. Checks linearity.



**1004-A VIDEO TRANSMISSION TEST SIGNAL RECEIVER** for precise differential phase and gain measurements. Companion for use with 1003-B.



**1521-A OSCILLOSCOPE CAMERA**—Polaroid type for instantaneous 1 to 1 ratio photo-recording from any 5" oscilloscope.

***Industry's most complete line of***

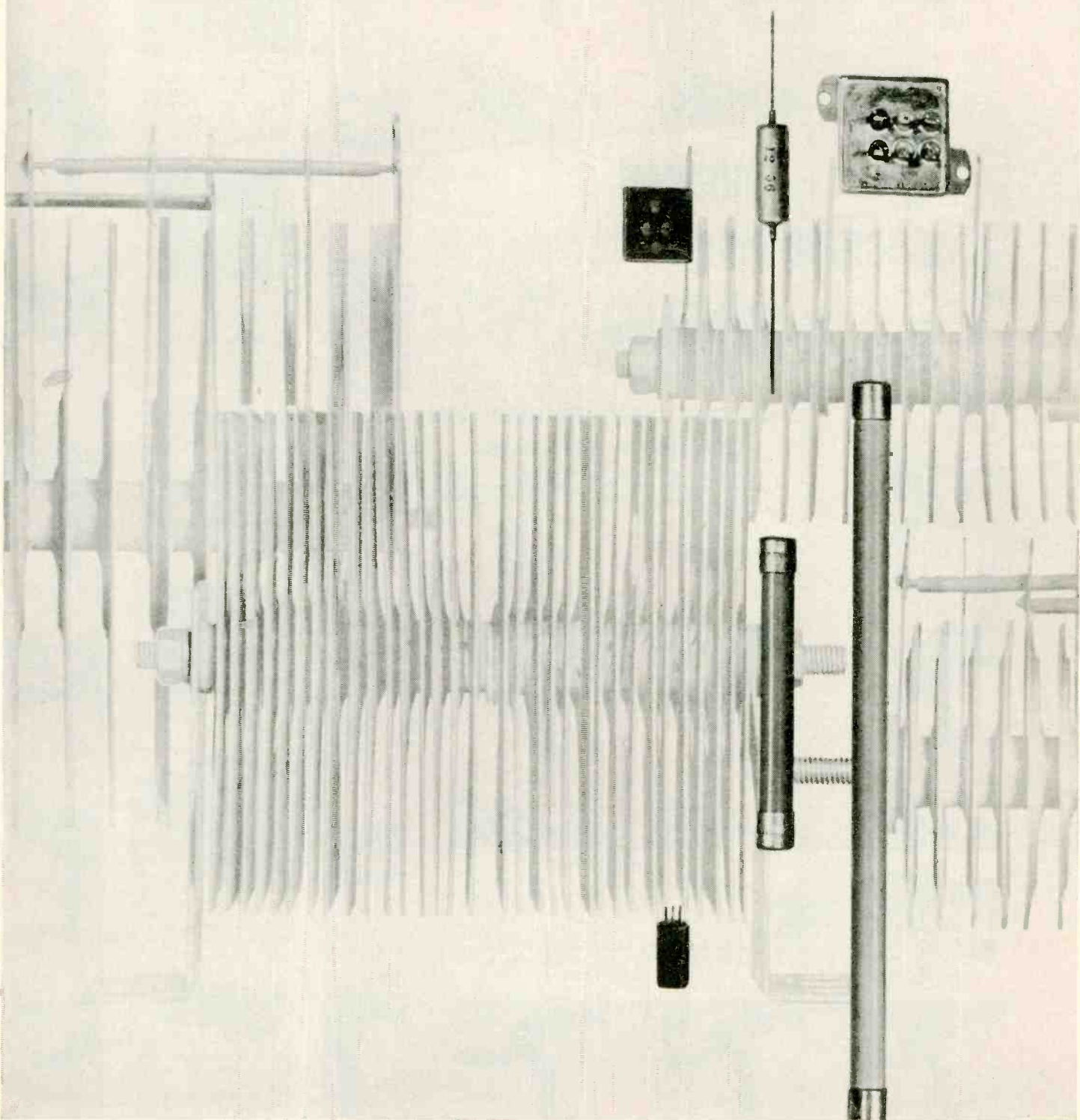





## ***control and power rectifiers***

Now available from a single source . . . a *complete* line of selenium rectifiers for d-c power supply, battery chargers and electronic circuitry.

Whether your needs are for 6 to 100,000 volts; 1.5 milliamp or 10,000 amperes; stacks, cans or cartridges (with a wide range of configurations), Westinghouse has a rectifier to meet your specific requirements.

Extensive life tests prove that in 20,000 continuous hours of service, the change in forward voltage drop of Westinghouse rectifier cells is less than 5%. Reverse leakage actually decreases with use. This superior performance . . . with up to 90% conversion efficiency . . . is assured by the vacuum evaporation deposit process and carefully controlled manufacturing conditions in making Westinghouse selenium cells.

For complete design and application information, call your Westinghouse sales engineer. Or, write Westinghouse Electric Corporation, P. O. Box 868, 3 Gateway Center, Pittsburgh 30, Pa.

J-22089

LOWEST FORWARD AGING RATE IN THE INDUSTRY!

YOU CAN BE SURE... IF IT'S

# Westinghouse

## AN (STANDARD)

For Aircraft, Electronic Instruments, Military, Industrial, and Commercial Applications



Standard AN-A, AN-B, AN-C... meet Specification MIL-C-5015C. Plastic inserts. 15 diameters, 260 insert layouts, 6 shell styles. AN3100 to AN3108 with all accessories. Interchangeability an outstanding feature. Many type assemblies directly available through distributors.

connect  
with  
**CANNON  
PLUGS**

## AN-E (INT. AN-M)

Where Vibration Resistance and Moisture Proofing Are Needed



AN-E Series... environment resisting. Replaces "old" AN-M. Meets Specification MIL-C-5015C. Resilient inserts. Completely sealed from cable to cable. Integral clamp and bushing. Grounding lugs. Interfacial sealing with grommet and grommet follower.

## The "AN" and associated series connectors offer the

### GS (HERMETICALLY-SEALED)

For Use Under Critical Pressure Conditions

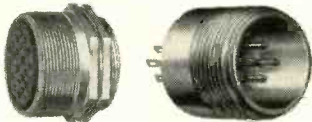

Hermetically sealed connectors... with steel shells and contacts to withstand high pressures. Available in GS (AN type), KH, RKH, U, BFH, TBFH. Insulation is Can-seal glass material, fused under high temperature to shell and contacts... giving true hermetic sealing when soldered or brazed to housing.

### STEEL SHELL FIREWALL

For Open Flame Protection Wherever High Temperatures Are Involved

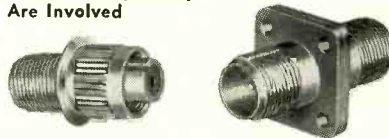

AN-K and Cannon FW Firewall Connectors... offer you the greatest variety of this type of connector. Cannon made the first firewall connector and continues the leader in the field. Wall—or box-mounting receptacles. Straight or angle 90° plugs. Crimp-on contacts. Inserts of asbestos-filled or glass-filled materials.

### CONNECTORS SUITABLE FOR POTTING

For Resistance to Moisture, Fuel Oil, Gasoline, etc.

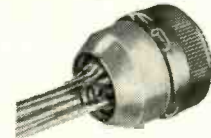

CA06 and CA3106 Types... developed for the Bu Aer Standard AN3106 type minus the end bell. Special plastic "cups" supplied for use as a mold while potting the rear of the connector. Weight saving. Grounding means available. Plastic or resilient inserts.

## widest selection of types for all applications to Spec. "MIL"

### AF, F (VIBRATION PROOF)

For Points of High Vibration Where Extra Strength Is Needed



Vibration Proof CA310\*F—CA0\*AF Solid Shell, Resilient Insert Connectors... Feature extra strong coupling nuts... in hex, spline, knurled types for airline use. In wall—or box-mounting, cord-connecting type receptacles. Straight or angle 90° plugs.

### AN EXTERNAL POWER

Power Connections—Batteries, Engine Starting, Aircraft, Oilfield, Industrial

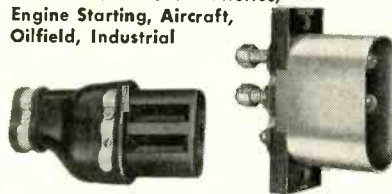

CA2551, AN2552, AN3114 and Other Cannon Types Offer Most Complete and Varied Line... in single, double, and three contact fittings. Really rugged! Designed and built for safe, positive connection and long-lasting service.

### AN ACCESSORIES

Cable Clamps, Conduit Fittings, Dummy Receptacles, Junction Shells, Dust Caps, Bonding Rings, Bushings, Adapters

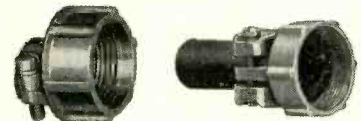

Featuring High-Quality Materials and Workmanship... including AN3057, AN-3057A, AN3420, AN3054, AN3055, AN3056, AN3058, AN3064, AN3066, AN3068, AN3111, 2120, 2245, 17530, 2209, 2182. Adaptable to all makes of AN connectors.

## Cannon Plugs—standard of quality for the industry

### W

For Underwater and Severe Moisture Conditions



W Waterproof Series... used underwater and on equipment operating in swamps, rivers, lakes, with underground cables—wherever conditions require thoroughly sealed fittings. Exceptionally rugged. AN type inserts. Acme threads on coupling nuts. Special rubber sealing ring. Special heavy duty cable clamp available.

OTHER SERIES... Audio Types—External Power Connectors—Switching Types—dc Solenoids—Guided Missile Launching Connectors—Miniatures and Sub-Miniatures.



Since 1915

Write Today for new, completely revised, up-to-date AN11 bulletin!

Please Refer to this Magazine or to Dept. 120

# CANNON PLUGS

CANNON ELECTRIC CO., 3208 Humboldt St., Los Angeles 31, Calif. Factories in Los Angeles; Salem, Mass.; Toronto, Canada; London, England; Melbourne, Australia. Manufacturing licensees in Paris, France; Tokyo, Japan. Contact our representatives and distributors in all principal cities.



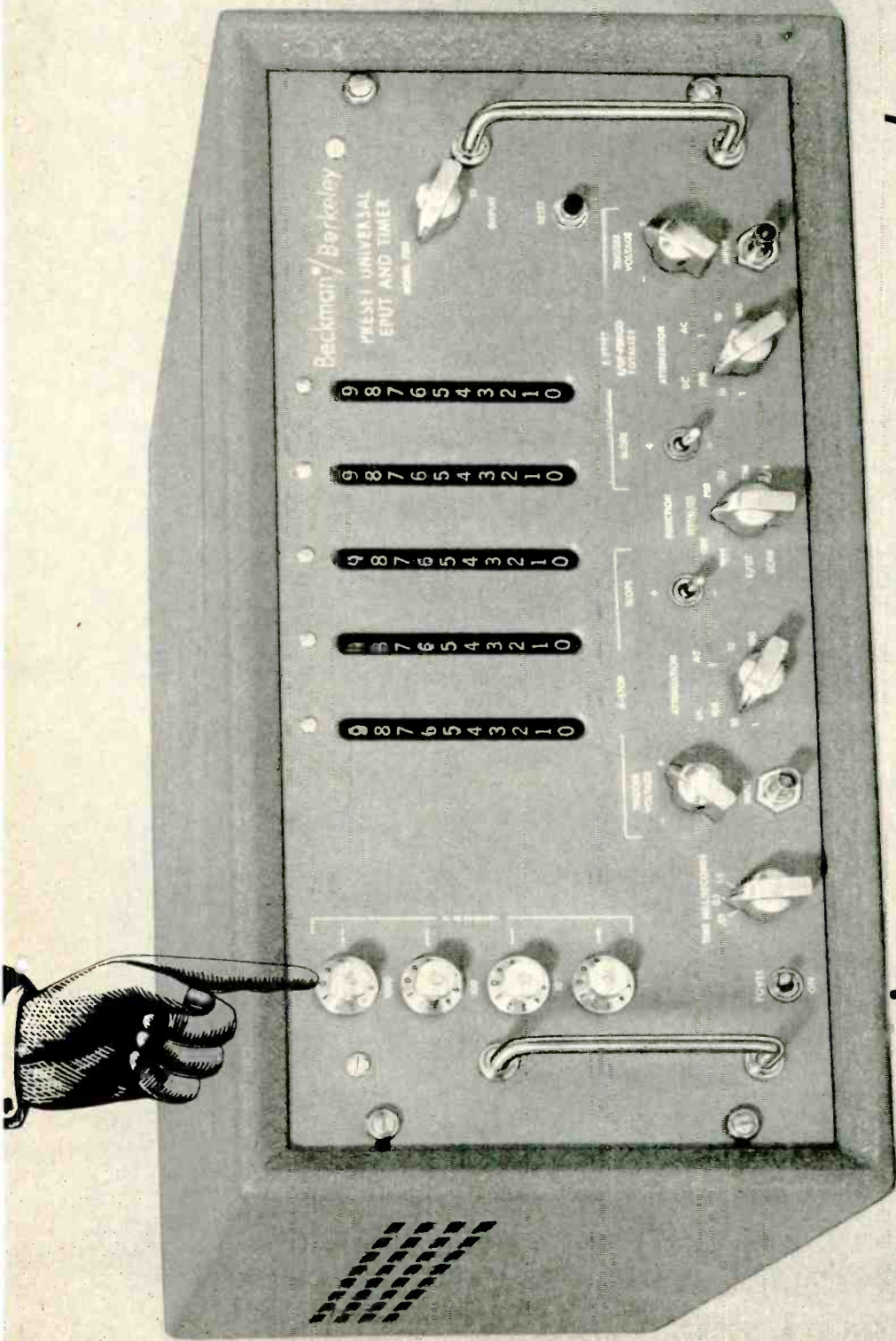

**NEW** . . . . . **from Beckman®**

*Berkeley*

Variable Time Base Universal EPUT® Meters  
For Direct Digital Readout Without Conversion!



## NEW MODELS 7351 (shown on preceding page) and 7361

With their variable preset "count down" time bases, Models 7351 (100 kc) and 7361 (1 mc) Preset Universal EPUT\* Meters are unique multipurpose instruments. Regardless of transducer conversion factors, results may be read in direct digital form by merely selecting the proper time base. These instruments will measure time intervals of any number of periods from 1 to 10,000 over the frequency range 0 to 10 kc, totalize a selectable sequence of events, divide frequency, function as single preset counters, generate pulses of varying frequency.

Applications include precise measurement of velocity, pressure, flow, viscosity, low and high frequency, frequency ratio and period, and tachometry.

## NEW MODEL 5230 PORTABLE UNIVERSAL EPUT\* METER

Combines many features of the popular Beckman/Berkeley 7000 series in a new, light-weight portable instrument to perform the functions of a counter, timer, time interval meter, EPUT\* meter, frequency, frequency ratio or period meter. Printed circuitry contributes to compact design, increased reliability and economical cost.



## MODELS 7350 and 7360 UNIVERSAL EPUT\* METERS

**DESCRIPTION**—These truly universal instruments combine high-speed electronic counting with a precision time base in multi-purpose circuitry. They function as counters, timers, time-interval meters, EPUT\* meters, frequency, frequency ratio or period meters, or as secondary frequency standards.

All models have provision for standardization against WWV and may be coupled to external frequency standards. Connections are provided for driving Berkeley digital printers, data converters, or in-line remote readout units.

### FEATURES

- 1 0.1 v rms sensitivity
- 2 Step attenuators: trigger-adjusted noise discriminators
- 3 More stable frequency dividers
- 4 Electronic (not relay) reset
- 5 External frequency standard input connection
- 6 AC or DC coupling of all input circuits; 10 megohm input impedance
- 7 Multivoltage accessory socket to power photocells, etc.
- 8 Binary-coded output with direct connection to digital printers, data converters, in-line readouts, etc.
- 9 Crystal-controlled time marker output
- 10 Unitized modular design
- 11 Larger, brighter readout numbers
- 12 Modern-styled all-aluminum cabinets

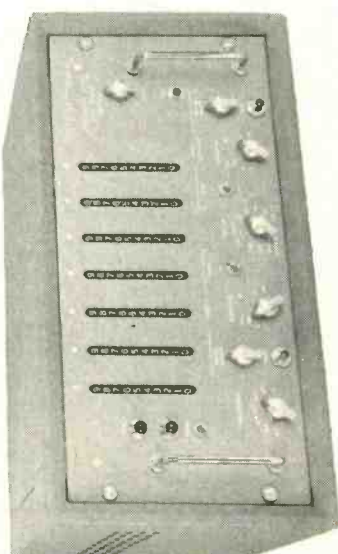
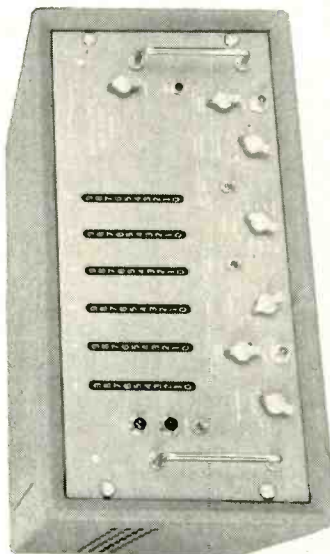



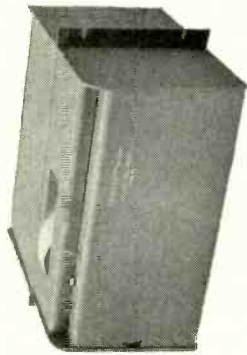

**MODEL 1452 DIGITAL PRINTER**

Automatically and permanently records information from any Berkeley 5571 or 7000 Series instrument, prints data in digital form on standard adding machine tape from printer and scanner in one compact unit. May be modified to print "Time" or "Code" information simultaneously with data. Rack or bench mounted; available in up to 8 digits. One printout every 0.85 seconds. Price (6-digit), \$950.00.



**MODEL 5916 IN-LINE READOUT**

Large, illuminated in-line IN-PLANE figures reduce fatigue and error. Ideal for remote observation of data. Connects directly to any Berkeley 5571 or 7000 Series instrument. Presentation rate up to 15 per second; accepts binary voltages. Price (six digit unit), \$775.00.

**TRANSDUCERS**

A large number of transducers especially designed for use with Berkeley counting, timing, and frequency measuring equipment are available. These include tachometer pickups, photocells, and light sources. Specifications and technical description on request.

**SPECIFICATIONS & PRICES**

**NEW SPECIAL PRODUCTS SECTION SPEEDS SERVICE**

A new department with complete specialized engineering, model shop and manufacturing facilities is ready to give prompt service on special modifications to standard Beckman/Berkeley instruments, or supply special equipment to your specifications.

BRIEF SPECIFICATIONS	Model 5230	Model 7350	Model 7351	Model 7360	Model 7361
RANGES-FREQUENCY	0 cps to 100 kc	0 cps to 100 kc	0 cps to 100 kc	0 cps to 1 mc	0 cps to 1 mc
TIME INTERVAL	100 $\mu$ sec to 10 <sup>-6</sup> sec	10 $\mu$ sec to 10 <sup>-6</sup> sec	10 $\mu$ sec to 10 <sup>-6</sup> sec	1 $\mu$ sec to 10 <sup>-6</sup> sec	10 $\mu$ sec to 10 <sup>-6</sup> sec
PERIOD	0 cps to 10 kc	0 cps to 100 kc	0 cps to 10 kc	0 cps to 1 mc	0 cps to 10 kc
TIME BASES	0.1 and 1 sec	10 $\mu$ sec to 10 sec	Time Interval* Generator	1 $\mu$ sec to 10 sec	Time Interval* Generator
CODED OUTPUT FOR DRIVING DIGITAL RECORDER, ETC.	\$30.00 extra	yes	yes	yes	yes
COUNT CAPACITY (READOUT)	4 digit	6 digit	5 digit	7 digit	6 digit
ACCURACY	± 1 count, ± oscillator stability				
OSC. STABILITY	1 part in 10 <sup>6</sup> per day	3 parts in 10 <sup>6</sup> per week	1 part in 10 <sup>6</sup> per day	3 parts in 10 <sup>6</sup> per week	1 part in 10 <sup>6</sup> per day
INPUT SENSITIVITY	0.25 v rms	0.1 volt rms**			
INPUT IMPEDANCE	1 megohm, direct	10 megohm, dc or ac coupled			
TRIGGER SLOPES	Positive or negative				
CABINET DIMENSIONS	12" H x 8" W x 14" D	10 1/4" H x 20 3/4" W x 16 1/2" D (Rack Panel - 8 3/4" x 19")			
APPROX. SHIPPING WT. LBS.	30	60	50	60	50
PRICE: (F.O.B. FACTORY)	\$575.00	\$945.00	\$1295.00	\$1245.00	\$1445.00

\*Variable from 0.1 millisecond to 0.9999 sec in 0.1 millisecond increments and from 1 millisecond to 9.999 sec in 1 millisecond increments  
 \*\*Modification for 5 millivolt sens. @ 5 cps available, \$50.00 extra

Complete technical specifications on Beckman/Berkeley Universal EPUT\* meters and accessories are available promptly on request. Please address Dept. G-8

**Beckman**

*Berkeley Division*

2200 Wright Avenue, Richmond 3, California  
 a division of Beckman Instruments, Inc.

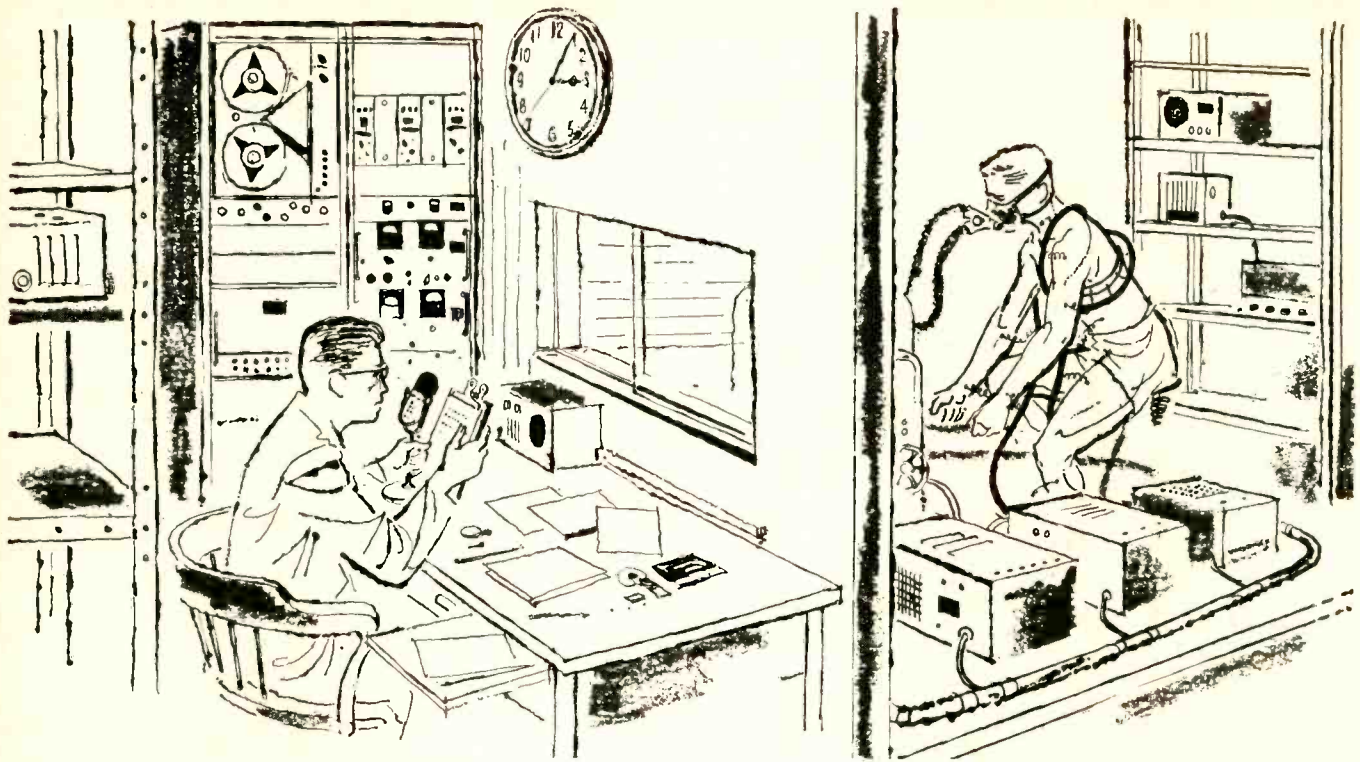

## PUTTING BODY RESPONSES ON TAPE SPEEDS RESEARCH IN HUMAN PHYSIOLOGY

*Q: How do environmental conditions affect the total physiology of a human being?*

*Q: What are the effects of age, sex, health, etc., on work performance, and what range of variation can be expected within each group?*

*Q: How does the body regulate temperature and respiration under varying environmental conditions and exercises?*

The answers to the questions posed above cannot be found in the literature. Why? Not too little data, but far too much . . . so scattered that it cannot be brought together for integration and analysis. Now, strides forward in the techniques of automatic data handling may help scientists provide the answers.

Consider the problem posed by the study of a man repeating a simple manual task. The force he exerts can be measured by placing him on a ballistic platform. But ten minutes of experiment might easily necessitate a full day of computation. Repeating the experiment in other environments multiplies the days of computation. To study the effect of fatigue on his performance means a full day of experiment in each environment . . . months of computation. A significantly large number of

subjects assures valid conclusions, but means scores of man-years of mathematics. And integrating body temperature, heart rate, etc., into your results requires scores more.

The availability of large computers has now made such analysis conceivable. But only the development of magnetic tape data recording has made it feasible.

Magnetic tape is the vital link between experiment and computer. Accepting electrical signals from measuring instruments, it stores the information for long periods of time . . . plays it back in exactly the same form . . . the one language all electronic data analysis equipment understands. It further offers the facility of high data storage density. Far more data can be economically stored than a single typical experiment demands, and the surplus data used in future studies. Portability permits data recorded on the spot to be analyzed a continent away with no loss of time or accuracy.

The techniques of magnetic tape data recording were first developed less than a decade ago by the Davies Laboratories Division to solve similar problems in the field of aircraft vibration analysis. The first systems specifically designed for physiological research have just recently been

placed in operation. Designed for flexibility, they economically meet initial demands for data capacity, yet may be expanded at little expense to satisfy changing requirements. Up to thirty-six individual tracks of data can be simultaneously recorded . . . and interchangeable electronics permit recording each kind of data by the most desirable technique . . . Direct, FM, or PWM. Up to six recording and playback speeds can be chosen at the flip of a switch for data expansion or contraction. The same system will play back data to associated analysis equipment, or the reel can be shipped to remote analysis facilities.

Considerable information on magnetic tape data recording and how it might be best applied to your data recording, reduction, and analysis needs is provided in our Bulletin 1001, available on request to Minneapolis-Honeywell Regulator Company, Davies Laboratories Division, 10721 Hanna Street, Beltsville, Maryland. WEBster 5-2700

MINNEAPOLIS  
**Honeywell**  
DAVIES LABORATORIES DIV.



in **color** tv, too

# CRUCIBLE PERMANENT **MAGNETS**

*for beam correctors, color purifiers and color equalizers  
give maximum energy . . . minimum size*

Designers of electronic and control equipment can count on a *consistently higher* energy product with Crucible alnico magnets. *It means greater power from a minimum size magnet!*

And they're available in practically any size you want—from a fraction of an ounce to several hundred pounds. What's more, Crucible alnico permanent magnets can be sand cast, shell molded, or investment cast to your exact size, shape, or tolerance requirements.

Crucible has been a leading producer of these permanent magnets ever since alnico alloys were developed. And their manufacture is backed by over a half century of fine steelmaking experience. That's why so many magnet applications begin at Crucible.

*Crucible Steel Company of America,  
The Oliver Building, Mellon Square,  
Pittsburgh 22, Pa.*

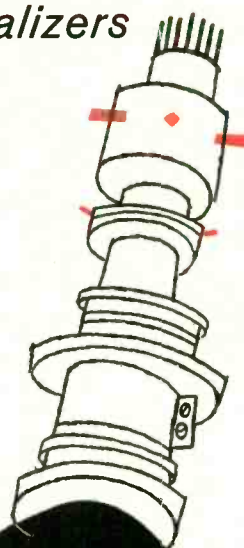

**CRUCIBLE**

first name in special purpose steels

**Crucible Steel Company of America**



**FLASH...**  
**an \*Original Idea!**

**You Can  
 Count On...  
 to Pay Off!**



Series 120<sup>5</sup>  
 Reset Magnetic Counter

It's the \*Original Equipment idea . . . which simply means that, when you're figuring on electrical or mechanical counters in any new product, it pays to *design them in, when you begin.*

For then Veeder-Root quite likely can save you time and money by adapting or modifying a *standard* counter to your needs, instead of a special which you might specify on your own. This solves the counter problem . . . and saves you time in engineering, purchasing and assembly.

What's more, you give your product new sales-advantages: Direct-reading digits, instead of hard-to-read dials and verniers . . . instant remote indication if needed . . . up-to-the-minute performance records that serve as a basis for production-*Control*, and as proof of your performance guarantee. So don't let counters take a back seat in your new-product plans. *Design them in, when you begin . . .* it pays in many ways. Do you have the newest Veeder-Root Catalog? Write

**Everyone  
 Can Count on  
 Veeder-Root  
 INCORPORATED**



Hartford, Conn. • Greenville, S. C. • Chicago • New York  
 Los Angeles • San Francisco • Montreal  
 Offices and Agents in Principal Cities

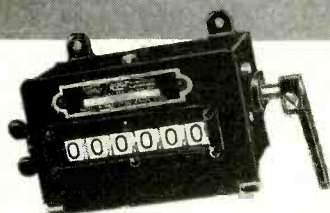

Series 1380  
 Box-Type Counter (Ratchet,  
 Revolution, or Geared)

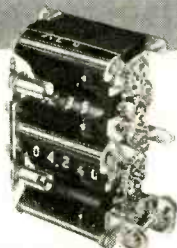

4-bank Counter for  
 Radio Transmission Equipment

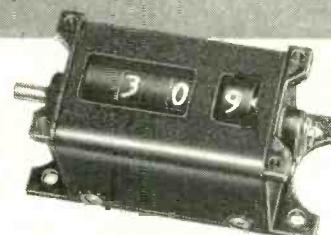

360-degree Bearing Counter



# new **OAK** chopper needs no phase-shift circuit!

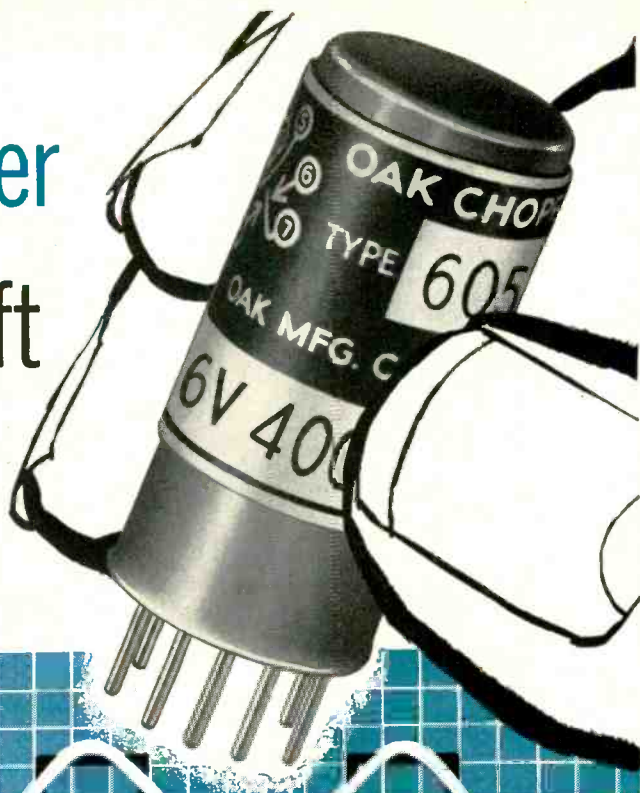

**HAS 0° or 180°  
PHASE-LAG  
"DESIGNED-IN"**

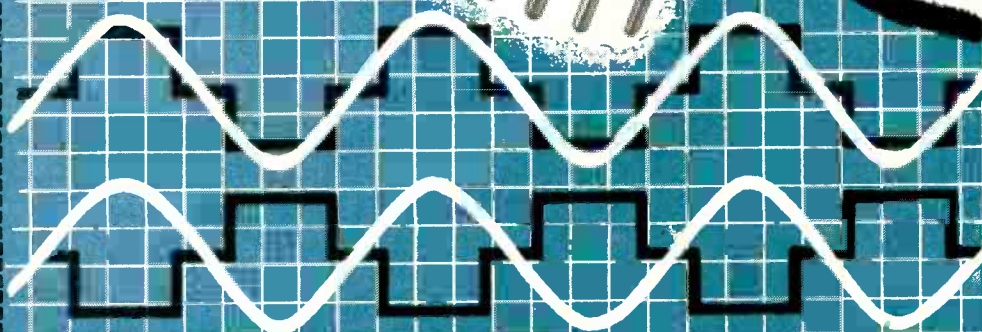

## SPECIFICATIONS

**Coil:** Current, 25 ma; impedance, 190 ohms; resistance, 160 ohms.

**Contacts:** Dwell time, 150-160°; rating, 100 V, 2 ma. Resistance, less than 200 milliohms.

**Phase Change:**  $\pm 10^\circ$  At constant 400 cps under all conditions of use and life.

**Noise:** Less than .5 millivolt RMS into 1 meg.

**Vibration:** 10-55 cps.

**Weight:** Less than 1 oz; dia. 11-16".

**Height:** Sected, 1  $\frac{5}{8}$ ".

Inherent in every device of the vibrating reed type are two phase-lags—an electrical phase angle resulting from the current lagging the applied voltage in the drive coil, and a mechanical angle due to the inertia of mass in the moving reed, lagging further behind flux from the driving current. In OAK's new Type 605 Chopper, these two lags have been carefully brought to a total of 180°. Thus, the chopper can be so wired to be exactly 180° out of phase, or reversed to be 360° out (in phase). This design eliminates the R-C circuit ordinarily needed to bring this coincidence of voltage and output phase—saving circuitry, parts, and weight.



Shown at the left is the new chopper with side mount. Also available with flattened and pierced pins, solder loops, or as a vertical flange mount unit.

**OAK**  
MFG. CO.



Dept. G, 1260 Clybourn Ave., Chicago 10, Illinois  
Phone: MOhawk 4-2222

Switches • Rotary Solenoids • Special Assemblies • Choppers • Vibrators

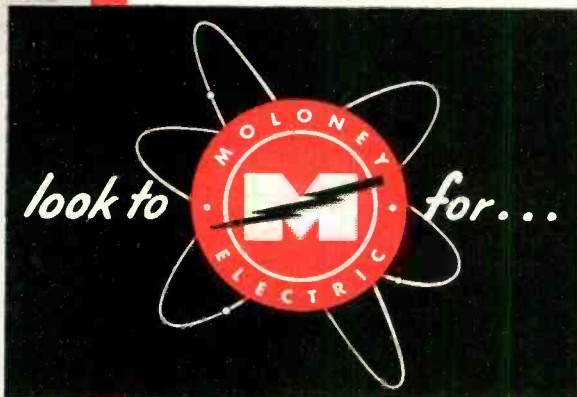
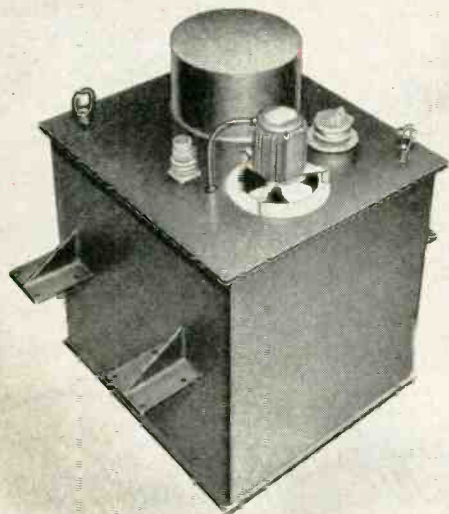

## UNIT RECTIFIERS

(using semi-conductors)

**And Get These Inherent Advantages!**

**Long Life • Rugged • Lightweight**

**No tubes to replace**

**Completely Packaged Unit**

Now available—a Moloney power transformer, filter reactor and capacitor, where required, and either silicon, selenium, or germanium semi-conductors combined in a neat, compact unit to give single phase or three phase rectification at any frequency. These units are manufactured in all types from a minimum rating of five kilowatts.

Save *your* Engineering man hours! Just give us input and output characteristics, service, and applicable specifications. Then let Moloney simplify your Engineering and Procurement with a coordinated job—from A. C. to D. C.

Moloney know-how and experience can be applied to your particular power supply problems to produce a better unit tailored to your needs. Check with your Moloney representative today!

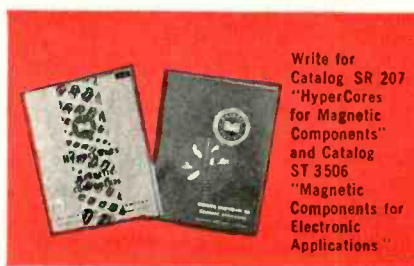
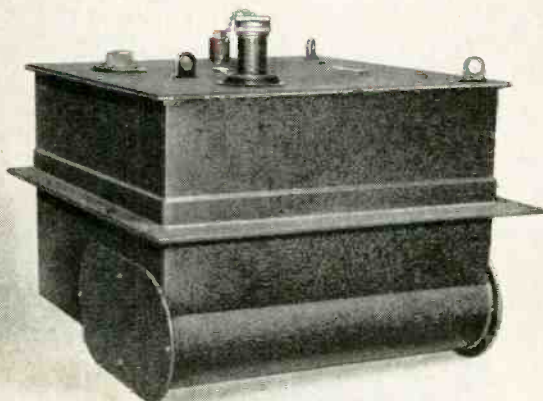
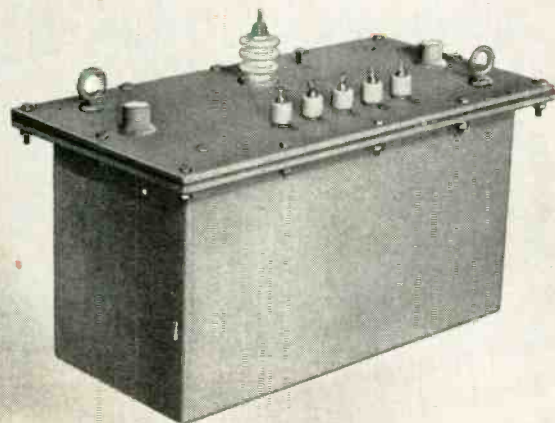

Write for  
Catalog SR 207  
"HyperCores  
for Magnetic  
Components"  
and Catalog  
ST 3506  
"Magnetic  
Components for  
Electronic  
Applications"

ME57-14

## MOLONEY ELECTRIC CO.

*Plate and Filament Transformers • Chokes • Unit Rectifiers • Modulation Transformers and Reactors • Pulse Transformers and Charging Chokes • HyperCores for Magnetic Components • Developmental Magnetic Components • Power and Distribution Transformers*

FACTORIES AT ST. LOUIS 20, MO., AND TORONTO, ONT., CANADA



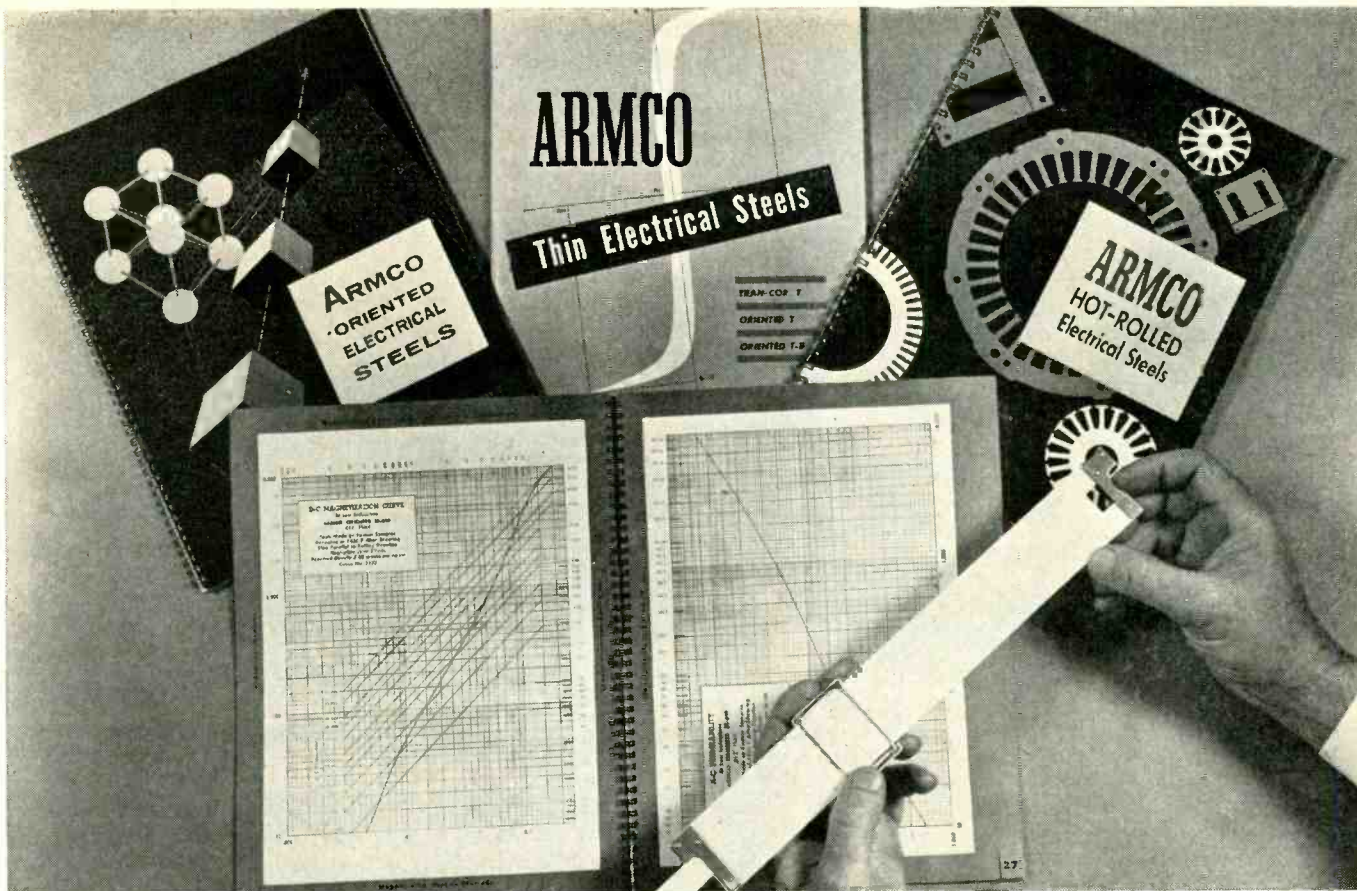

## ARMCO ELECTRICAL STEELS HELP YOU TAKE THE "GUESSTIMATING" OUT OF DESIGN

When you use Armco Electrical Steels in designing products, you have a two-way opportunity to make performance in service more closely approach designed performance. One reason is that accurate data on magnetic and electrical properties are available; another is the consistent high quality of Armco Steels.

### Design Data

You can calculate the performance of your product more precisely with available design data on Armco Hot Rolled, Oriented, and Thin Electrical Steels. Your selection of grade and gage can be based on precise data that helps assure guaranteed performance. You don't have to make educated guesses based on empirical formulae or extrapolation of meager data.

### Consistent High Quality

More than a half century of electrical steel production and research has made possible the consistent high quality of Armco Electrical Steels. You are assured uniform magnetic properties. This, plus special Armco processing, produces fabricating qualities and tolerances that enable you to achieve the full magnetic potential of each grade.

### Special Grades Offer Added Advantages

Besides standard grades of electrical steel, Armco produces many special grades that offer you unusual opportunities to improve the performance and reduce the cost of your products. For example, there is Armco A-6 for high permeability at low and moderate inductions; Armco Thin Electrical Steels with exceptional magnetic properties for high frequency applications.

Write us at the address below for complete information and design data. Just tell us what you make.

Armco Steel Corporation 1867 Curtis St., Middletown, Ohio

Please  
send me  
information on

- Armco Hot Rolled Electrical Steels  
 Armco Oriented Electrical Steels  
 Armco Thin Electrical Steels

Name \_\_\_\_\_

Company \_\_\_\_\_

Street \_\_\_\_\_

City \_\_\_\_\_ Zone \_\_\_\_\_ State \_\_\_\_\_

# ARMCO STEEL CORPORATION

1867 Curtis Street, Middletown, Ohio

SHEFFIELD STEEL DIVISION • ARMCO DRAINAGE & METAL PRODUCTS, INC. • THE ARMCO INTERNATIONAL CORPORATION





**Now!**

## New low cost oscillator covers entire audio band in one sweep of the dial

-hp- 207A Audio Sweep Oscillator—continuous output 20 cps to 20 KC—flat response, low distortion—may be motor driven or coupled to recording device

### SPECIFICATIONS

**Frequency Range:**

20 cps to 20 KC, covered in one range.

**Accuracy:**

±4% including changes due to warm-up, aging components, tubes, etc.

**Dial:**

Six-inch diameter dial calibrated over 300° of arc.

**Frequency Response:**

±1 db entire frequency range.

**External Frequency Control:**

¼-inch shaft, extending from rear of instrument, rotation approximately 150° for full frequency coverage.

**Output:**

10 volts into 600 ohm rated load, balanced or 1 terminal at ground.

**Output Control:**

Decreases level continuously by more than 40 db.

**Distortion:**

Less than 1% over entire frequency range.

**Hum Voltage:**

Less than 0.1% of rated output. Decreases as output is attenuated.

**Power:**

115/230 volts, ±10%, 75 watts.

**Dimensions:**

Cabinet Mount: 7½" wide, 11½" high, 15¼" deep. Rack Mount: 19" wide, 7" high, 12½" deep.

**Weight:**

Approximately 25 lbs.

**Price:**

\$275.00

*Data subject to change without notice*

Here at last is a low cost, high quality oscillator providing the time-saving convenience of continuous single-sweep frequency coverage from 20 cps to 20 KC. The instrument has high waveform purity, constant output, high stability and dial calibration which is essentially logarithmic. Band switching and resulting transients are eliminated. A flexible 10 volt output can be used balanced or with one side grounded.

*Model 207A may be swept by hand, motor driven, tuned remotely or coupled to a recording device by means of a shaft extended through the rear of the cabinet.*

Priced at just \$275.00, this new -hp- oscillator is an outstanding value and particularly convenient for such audio tests as speaker frequency response and amplifier flatness, measuring characteristics of filter networks, complex coupled systems and industrial transducers, or automatic response measurements where response is recorded or viewed on an oscilloscope.





**650A** — highly stable, wide band; 10 cps to 10 MC. For audio, supersonic, video, rf measurements. Output 15 mw/3 volts. Frequency response flat  $\pm 1$  db. \$490.00.



**200AB** — for audio tests, 20 cps to 40 KC. Output 1 watt/24.5 volts. Simple to use, compact, rugged. \$130.00.



**233A** — carrier test oscillator covering frequencies 50 cps to 500 KC. Output 3 watts/60 ohms. \$475.00.



**200CD** — popular precision instrument for audio and ultrasonic tests. 5 cps to 500 KC; output 160 mw/10 volts; 20 volts open circuit. \$160.00.

**11**

**additional**

**-hp- quality oscillators**

- outstanding value
- complete coverage  
**0.008 cps to 10 MC**
- stable RC circuit pioneered by **-hp-**
- each instrument designed to do a specific job best



**206A** — very low distortion; for high quality, high accuracy audio tests. Covers 20 cps to 20 KC; output +15 dbm. \$565.00.



**200QJ** — extreme accuracy for interpolation and frequency measurements. Covers 6 cps to 6 KC, output 160 mw/10 volts; 20 volts open circuit. \$275.00.



**205AG** — time-tested convenience for high power tests, gain measurements. 20 cps to 20 KC, 5 watts output. \$440.00.



**200T** — custom-engineered for telemetry, carrier current tests. 250 cps to 100 KC, output 160 mw/10 volts; 20 volts open circuit. \$350.00.

**HEWLETT-PACKARD COMPANY**

4170A Page Mill Rd., Palo Alto, Calif., U.S.A.  
Cable "HEWPACK" • Davenport 5-4451  
Field engineers in all principal areas



World's most complete line of fast, accurate, easy to use oscillators!



**202C** — replaces famous 202B for low frequency measurements 1 cps to 100 KC. Output 160 mw/10 volts; 20 volts open circuit. \$500.00.



**202A** — for servo, vibration, medical and other very low frequency measurements. 0.008 to 1,200 cps. Output 20 mw/10 volts. \$465.00.



**201C** — specifically designed for high quality audio tests. Covers 20 cps to 20 KC. Output 3 watts/42.5 volts. \$225.00.

4170

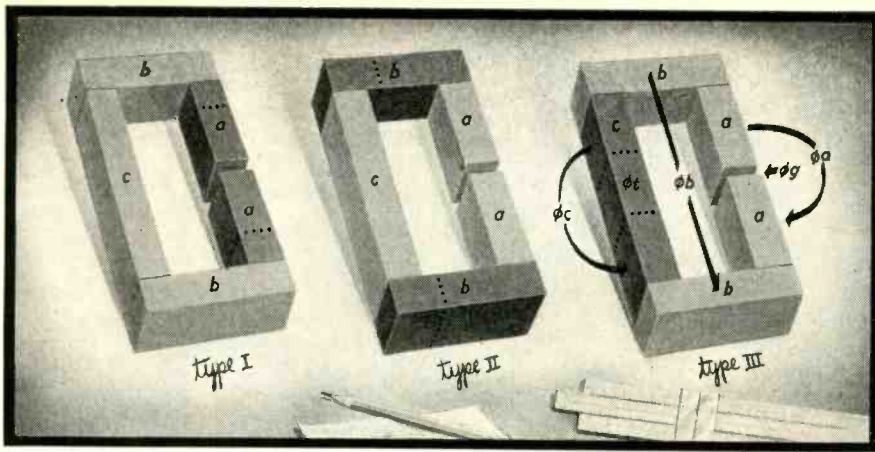

## How You Can Save Time Estimating Leakage Factors for Magnetic Circuits

Computing even approximate values for leakage flux in magnetic circuits is a time consuming job. The research department of Indiana Steel recently undertook a series of studies, supported by the U.S. Air Force, to simplify these computations. Dr. R. K. Tenzer reported the results of this work, which reduce the time in computing leakage flux up to 90% by diminishing the number of mathematical operations necessary.

The investigations were done on circuits with permanent magnets; the results were also found applicable to unsaturated electromagnetic circuits when the coil-covered parts were treated as permanent magnet parts.

After checking values obtained by this method with actual measured values for many Type I, II, and III magnetic circuits, deviations were found to be less than  $\pm 10\%$ .

### Leakage Flux, Leakage Factor

Because of magnetic leakage, only a part of the total flux through the neutral zone of the permanent magnet is found in the air gap. The difference between these two values is known as leakage flux. Mathematically this is:

$$\phi_L = \phi_t - \phi_g \quad (1)$$

In practical design, leakage is best considered as a factor stated thus:

$$\sigma = \frac{\phi_t}{\phi_g} = 1 + \frac{\phi_L}{\phi_g} \quad (2)$$

For simplification, the flux can be assumed to follow three basic, probable paths:  $\phi_a$  between parts  $a$ ,  $\phi_b$  between parts  $b$ , and  $\phi_c$  along part  $c$ . The equation above then becomes:

$$\sigma = 1 + \frac{\phi_a + \phi_b + \phi_c}{\phi_g} \quad (3)$$

With  $\phi = mmf \times P$ , this formula can be written:

$$\sigma = 1 + \frac{1}{P_g} \left( \frac{mmf_a}{mmf_g} P_a + \frac{mmf_b}{mmf_g} P_b + \frac{mmf_c}{mmf_g} P_c \right) \quad (4)$$

Letting the  $mmf$  ratios be denoted by  $K$ ,

$$\sigma = 1 + \frac{1}{P_g} (K_a P_a + K_b P_b + K_c P_c) \quad (5)$$

This becomes the basic equation for numerical calculations of leakage factors after introducing simple expressions for leakage permeances and  $mmf$  ratios.

### Simplified Leakage Permeances

The following formulas have been found satisfactory for leakage permeances between soft steel parts:

$$P_a = 1.7 \times U_a \times \frac{a}{a + L_g} \quad \text{where } U \text{ is cross-section perimeter;} \quad (6)$$

$$P_b = 1.4 \times b \times \sqrt{\frac{U_b}{c} + .25} \quad (7)$$

where  $U_b/c$  is greater than .25 and less than 4. The total length of part  $b$  is used.

Since permanent magnets have a neutral zone which does not contribute to leakage, the value of 2/3 of the magnet's total length is used when computing leakage permeances—this is the effective length  $a'$  and  $b'$  to compute  $P'$ ; thus the two equations above become:

$$P'_a = 1.7 U_a \frac{.67a}{.67a + L_g} \quad (6a)$$

and

$$P'_b = 1.4 \times .67b \sqrt{\frac{U_b}{c} + .25} = .67 P_b \quad (7a)$$

When part  $c$  consists of a permanent magnet (Type III) its permeance can be calculated as:

$$P_c = .5 U_c \quad (8)$$

The permeance of the air gap itself is

$$P_g = A_g / L_g \quad (9)$$

### Simplified MMF Ratios

Simplifying the  $mmf$  ratios is done by neglecting the reluctance in soft steel parts; so

$$mmf_a = mmf_b = mmf_g \text{ or } K_a = K_b = 1 \text{ (} mmf_c = 0 \text{ so } K_c = 0 \text{).} \quad (10)$$

Since the  $mmf$  along permanent magnet parts is not constant, integral values ( $mmf$ ) are used. Experiments showed that 2/3 of the  $mmf_a$  was the effective  $mmf$  for leakage flux between permanent magnet parts; thus

$$\overline{mmf}_a = \overline{mmf}_b = \overline{mmf}_c = 2/3 mmf_g$$

or

$$K_a = K_b = K_c = 2/3 \quad (11)$$

### Basic Formulas

By inserting the permeances for soft steel into equation (5), the general formula becomes:

$$\sigma = 1 + \frac{L_g}{A_g} \left( K_a \times 1.7 U_a \frac{a}{a + L_g} + K_b \times 1.4 b \sqrt{\frac{U_b}{c} + .25} + K_c \times .5 U_c \right) \quad (12)$$

This formula contains only constants and dimensions; and by the two following rules this can be modified into the three basic equations for the Type I, Type II, and Type III circuits.

Rules: (1) For leakage flux paths between soft steel parts, use total lengths and constant  $K$  of 1. (2) For leakage flux paths between permanent magnet parts, use 2/3 of lengths and  $K$  of .67.

The following provide the leakage factors for the three types of circuits:

Type I:

$$\sigma = 1 + \frac{L_g}{A_g} \times .67 \times 1.7 U_a \frac{.67a}{.67a + L_g}$$

Type II:

$$\sigma = 1 + \frac{L_g}{A_g} \left( 1.7 U_a \frac{a}{a + L_g} + .67 \times .67 \times 1.4 b \sqrt{\frac{U_b}{c} + .25} \right)$$

Type III:

$$\sigma = 1 + \frac{L_g}{A_g} \left( 1.7 U_a \frac{a}{a + L_g} + 1.4 b \sqrt{\frac{U_b}{c} + .25} + .67 \times .5 U_c \right)$$

For variations on these basic formulas, write today for the April-June issue of *Applied Magnetics* which also shows examples of the formulas in use.

### NEW DESIGN MANUAL READY

Write today for your copy of the newest edition of the Indiana Permanent Magnet Design Manual No. 6. Write to Dept. A-8.



THE INDIANA STEEL PRODUCTS COMPANY  
VALPARAISO, INDIANA

THE WORLD'S LARGEST MANUFACTURER  
OF PERMANENT MAGNETS

INDIANA  
PERMANENT  
MAGNETS

In Canada . . . The Indiana Steel Products Company of Canada Limited, Kitchener, Ontario



# NOW! the first all ceramic

## klystron

## tube for

## 1600 to

## 6500 mc

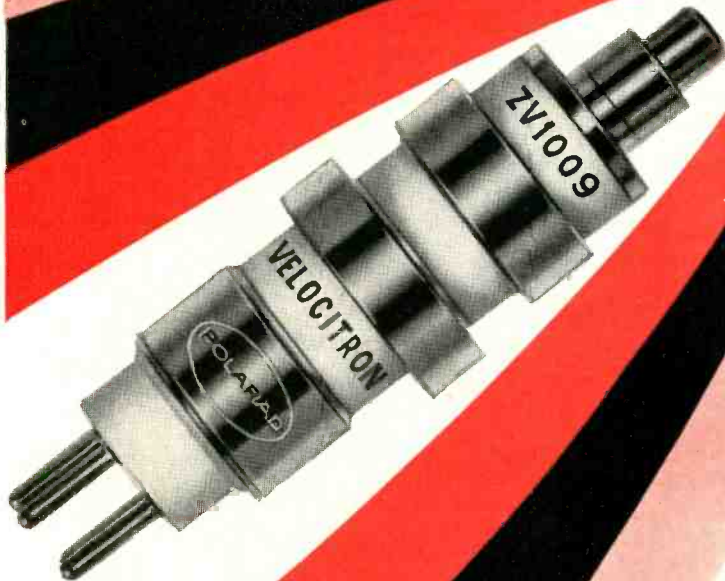

### RUGGEDIZED POLARAD ZV1009 VELOCITRON\*†

a physical and  
electrical replacement  
for klystron tubes 6BL6, 5836

The new Polarad ZV1009 all ceramic Velocitron is a premium, rugged tube designed for high temperatures, vibration and mechanical shock.

As a replacement for glass klystrons: the ZV1009 is less microphonic and less fragile. It is equipped with standard 4-pin connection.

As a basic design element: The all ceramic ZV1009 allows for higher ambient temperatures than any glass tube currents available. It is completely hard soldered.

#### SPECIFICATIONS: ZV1009 VELOCITRON

Reflector Mode .....	1¾	2¾	3¾
Cavity Mode .....	¾	¾	5/4
Frequency .....	2800	3200	5000 mc
Power Output Cutoff Voltage (approx.)...	+3	+3	+3 volts
Reflector Voltage (approx.) .....	-220	-120	-220 volts
Resonator Voltage .....	325	325	325 volts
Control Electrode Voltage (Full Power Output) .....	+10	+10	+10 volts
Cathode Current (average) .....	28	28	28 ma
Electronic Tuning Range (between Half Power Points—minimum).....	6	6	6 mc

Write directly to Polarad for complete data and design information.

\*Registered U.S. Trademark

†Manufactured under Western Electric Patents

**POLARAD**

PROVEN RELIABILITY

**ELECTRONICS CORPORATION**

43-20 34th Street · Long Island City 1, N. Y.

REPRESENTATIVES: Albany, Albuquerque, Atlanta, Baltimore, Boston, Chicago, Cleveland, Dayton, Denver, Englewood, Fort Worth, Kansas City, Los Angeles, New York, Philadelphia, Portland, Rochester, St. Louis, San Francisco, Schenectady, Stamford, Syracuse, Washington, D. C., Winston-Salem, Canada: Arnprior, Ontario.  
Resident Representatives In Principal Foreign Cities

# TAYLOR

Laminated Plastics  
Vulcanized Fibre

# Shop Talk

TAYLOR FIBRE CO.

Plants in Norristown, Pa. and La Verne, Calif.

PHENOLIC—MELAMINE—SILICONE—EPOXY LAMINATES • COMBINATION LAMINATES • COPPER-CLAD LAMINATES • VULCANIZED FIBRE

## Tips for designers

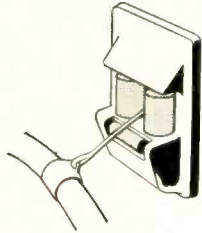

**Hose reel rollers**, made of Taylor Grade C thick-walled phenolic tubing, are part of cable attachment for gas pumps . . . selected for good wear and corrosion resistance, high mechanical strength.

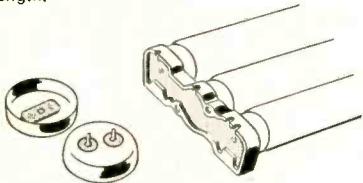

**Fluorescent tube ends** are fabricated of Taylor Grade X phenolic laminate . . . for mechanical strength, electrical insulation qualities, good punching and machining qualities.

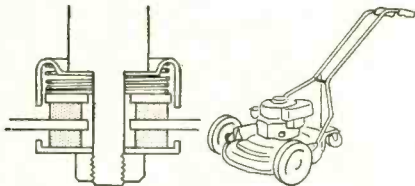

**Rotary lawn mower** utilizes abrasion resistance of Taylor phenolic laminate washer in slip-clutch attachment of drive shaft to cutting blade.

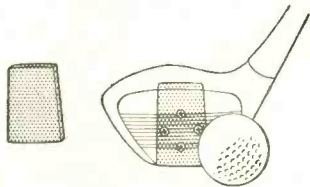

**Insert** in face of golf club, made of Taylor vulcanized fibre . . . withstands severe impact . . . gives long-lasting, long-hitting surface.

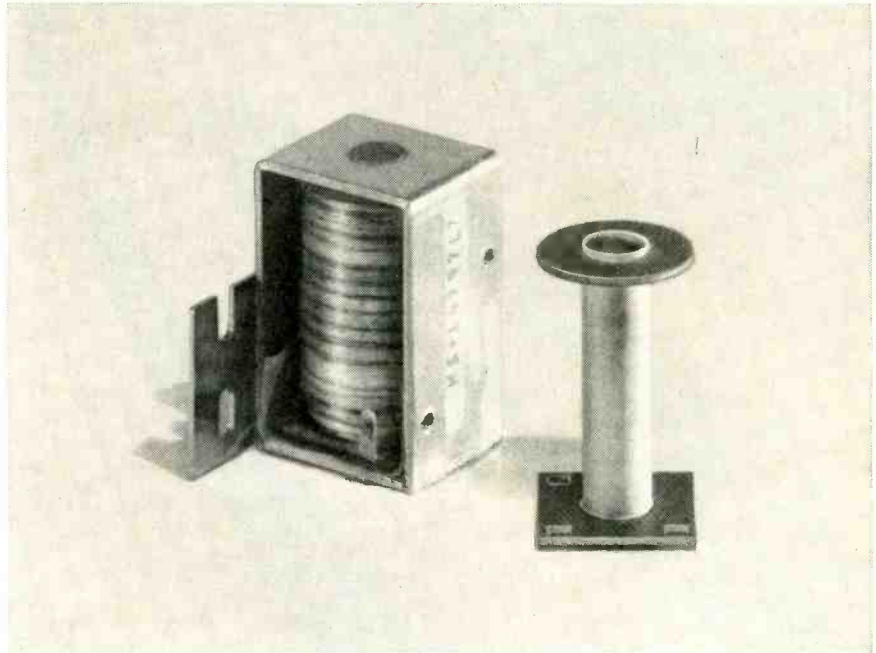

Both end pieces and the tube of this coil form assembly for radio frequency transformers are fabricated by Taylor for the Guardian Electric Mfg. Co. Taylor Grade G-5 sheet and tubing are used . . . for high mechanical strength, for high arc, flame and heat resistance, as well as superior tensile, flexural and impact strengths.

## Accurate laminated plastic components can shorten your production steps . . .

If close-tolerance work—such as this coil form assembly for radio frequency transformers—is one of your problems, then check with Taylor. This complete part was fabricated to very close tolerances by Taylor's Fabrication Division. The material—Taylor Grade G-5 laminate sheet and tubing—was selected for its high mechanical strength and for superior arc, flame and heat resistance.

Precision fabrication of laminates and vulcanized fibre is difficult . . . but Taylor can and is doing it, in a great variety of Taylor grades, and to extremely close tolerances. Many manufacturers have solved their fabrication and assembly problems with the help of this Taylor facility, by having parts supplied completely fabricated to specified tolerances,

ready for final assembly. With specialized equipment and advanced techniques, Taylor is prepared to simplify your production problems, safeguard delivery schedules, and eliminate inventory headaches.

You can put Taylor's Fabrication Division to work right now, helping to improve your product. Design to closer tolerances—Taylor can do the job. Taylor is equipped to handle any kind of fabrication—punching, drilling, grinding, forming, milling, and turning. You improve your product . . . reduce material costs.

Taylor's fabricating facilities and engineering staff are at your service. Contact your nearest Taylor sales engineer for a discussion of your particular requirements.

### TAYLOR SUPERIOR COPPER-CLAD LAMINATES

Taylor GEC (glass epoxy) Copper-Clad and Taylor XXXP 242 cold punching (paper-phenolic) Copper-Clad. Taylor uses high purity rolled copper on base materials with outstanding electrical properties.



# How to take an entire laboratory for a ride

Get complete mobile data despite shock and limits of space

This is the easy way — no such blue-sky dream as a shock-mounted, air-conditioned brick building on wings or wheels. The earthbound laboratory has a "double" that rides on airplanes, vehicles or ships or goes to location by manpower, muleback or dolly. The secret . . . an Ampex 800 mobile tape recorder which simultaneously gathers data for the laboratory's writing, viewing, simulating and computing instruments. Despite adverse environment, Ampex 800s closely match precision and versatility of laboratory tape recorders.

## AIRBORNE APPLICATIONS

Ampex 800s are widely used for environmental data, radio signals, radiation information, weapon countermeasures, flight parameters, etc.

At one airforce facility, the Ampex 800 rides in one aircraft to record telemetered signals from another (unmanned). Altitude greatly extends the horizon and tracking distance over which line-of-sight telemetered signals can be received.

Aircraft companies are tape recording vibrations, sounds, and other data far outside the range

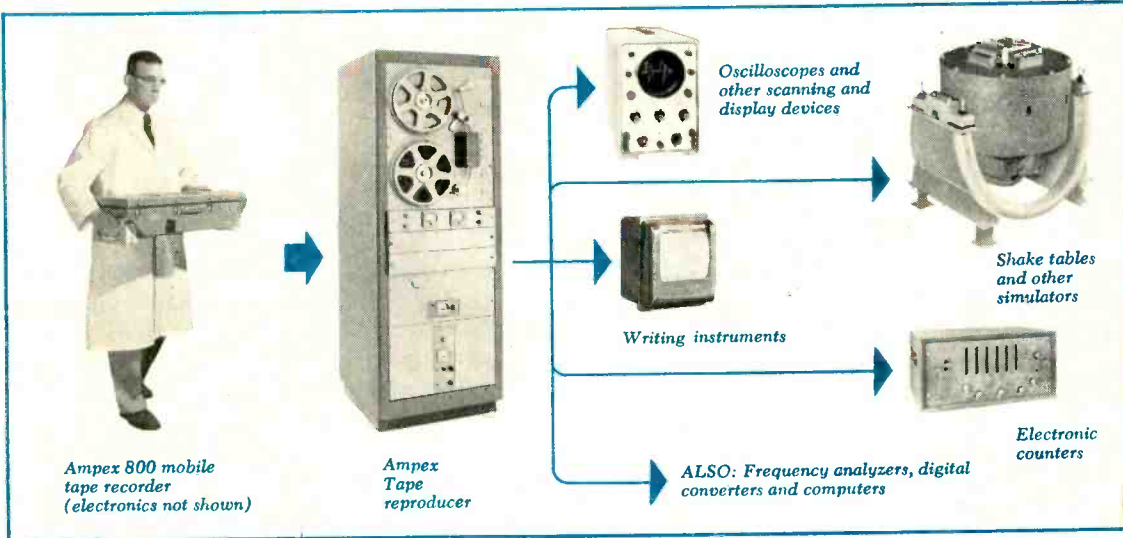

Only this mobile tape recorder and its associated equipment undergo the hazards and space limitations of the mobile test situation.

Reproduction of the tape recreates the original transducer voltage patterns, providing every other laboratory instrument with the same input it would have received if it too had been carried on the test. Data slowdown, speed-up, filtering, etc. can be used.



Ampex 800 tape transport, showing small size and ease of handling. This is the largest of the recorder components.

of other recording techniques. And in one major company's flight-test program, 420 channels of data are multiplexed onto a one-inch tape.

## GROUND, SHIPBOARD AND VEHICLE USE

The Ampex 800 is light and rugged, withstands handling and sets up quickly and easily. A research group studying earth-transmitted shock waves carries the Ampex 800 right to locations next to railroad tracks, airfields, highways and other areas of interest. An oil company uses a truck-mounted 800 to log oilwells in the fields.

The equipment stands shock, vibration and noise. In a shipboard installation, the Ampex 800 gathers data on closeby underwater explosions, enduring shocks transmitted through the ship. At an eastern jet-engine test facility, dolly-mounted Ampex 800s are wheeled out to the cells and get accurate data in an area of intense noise.

Do you have a mobile data acquisition problem on which we can help? Or would you like this tape-recording series mailed to you direct? For either request, write Dept. E-6

MAGNETIC  
TAPE  
APPLICATIONS  
BY AMPEX

ONE OF A SERIES

6



Series FR-100



Series 800 Mobile and Airborne



Model FR-200 Digital



Series PL-100 Loop Recorder



Series FR-1100

INSTRUMENTATION  
DIVISION

AMPEX  
CORPORATION

FIRST IN MAGNETIC TAPE INSTRUMENTATION

934 CHARTER STREET · REDWOOD CITY, CALIFORNIA

District offices serving all areas of the United States and Canada; Foreign Representatives in countries around the world.

# New Computer

Types 2N 377...2N 385

*Stability during life  
sets new standard for reliable use*

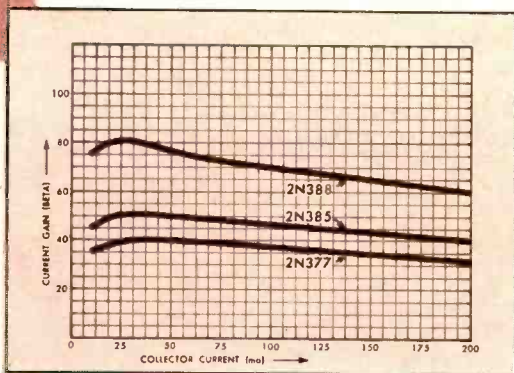

Typical current gain vs. collector current

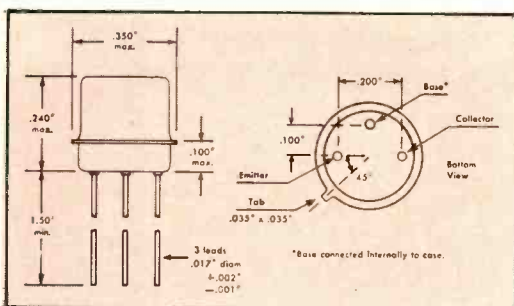

Triangular basing arrangement of the new computer transistors lends itself to printed circuit board insertion and dip soldering techniques.

New Sylvania NPN germanium alloy junction transistors, types 2N385, 2N377 and 2N388, are specifically designed for computer use. Higher, more constant beta over a wide range of operating conditions and fast switching time make the new Sylvania units ideal for computer and switching applications. They meet environmental tests typical of those required in military applications. In addition, the new Sylvania computer transistors meet RETMA size group 30 dimensions.

The outstanding characteristics of the new Sylvania transistors have been achieved in two ways—by new non-symmetrical design and by additional production steps. The optimum size relationship between emitter and collector has been determined for superior collector efficiency. This inherently better design is stabilized in production by carefully controlled surface treatment.

New Sylvania techniques are not only responsible for higher beta in the 2N385, 2N377 and 2N388 but for more constant beta at changing current levels. In addition, the design of the three types significantly improves leakage stability. Total dissipation is conservatively rated at 150 mw with ambient temperature at 25° C.

Thus, new and greater stability and reliability for computer and switching operations are built into these latest transistor developments from Sylvania. Call your Sylvania representative for further information.

“Sylvania—synonymous with  Semiconductors”



# Transistors

.... 2N 388



1,000-hour evaluation of the new Sylvania transistors at 100° C shows a new high in beta stability throughout the test after a small initial change.

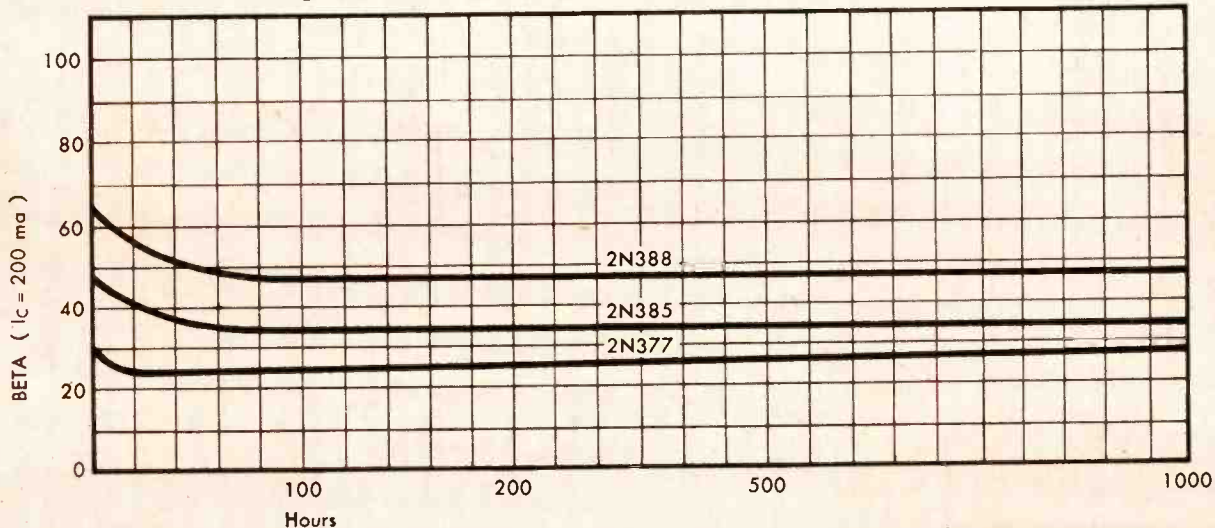

### Typical Characteristics (25°C)

	2N385	2N377	2N388
Collector Cut-off Current, $I_{CO}$ $V_{CB} = 25.0$ emitter open	5 $\mu$ a	6 $\mu$ a	6 $\mu$ a
Emitter Cut-off Current, $I_{EO}$ $V_{EB} = 15.0$ , collector open	5 $\mu$ a	6 $\mu$ a	6 $\mu$ a
Current gain, B $V_{CE} = 0.75$ , $I_C = 30$ ma	60	40	80
Current gain, B $V_{CE} = 0.75$ , $I_C = 200$ ma	45	30	60
Frequency Alpha Cut-off, $F_{\alpha CO}$ $V_{CE} = 5.0$ , $I_C = 10$ ma	6.0 Mc	4.0 Mc	8.0 Mc
Collector Current $I_C$ (-5,10K) $V_{CE} = 20$ V, $R_{BE} = 10K$ , $V_{BB} = -5V$	10 $\mu$ a	10 $\mu$ a	10 $\mu$ a
Storage or junction temperature	100° C.	100° C.	100° C.



# SYLVANIA

SYLVANIA ELECTRIC PRODUCTS INC.  
1740 Broadway, New York 19, N. Y.  
In Canada: Sylvania Electric (Canada) Ltd.  
Shell Tower Bldg., Montreal

LIGHTING • RADIO • TELEVISION • ELECTRONICS • ATOMIC ENERGY

# R-B-M Miniature Multipole Relays of Proven Reliability

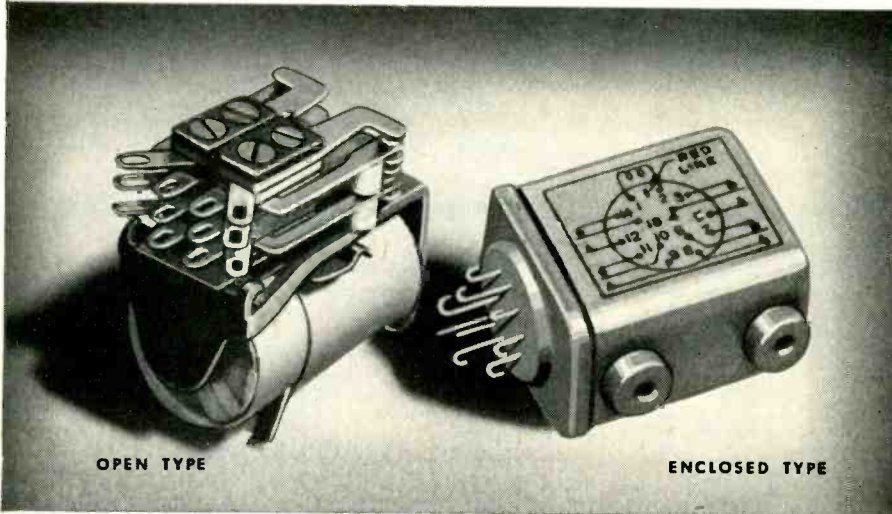

OPEN TYPE

ENCLOSED TYPE

*Light weight, Small Size Open and Hermetically Sealed Types for Electronic and Communication Application*

**APPLICATION:** R-B-M Miniature Multipole Relays are used where the prime factors in switching electronic circuits are small size, light weight and reliability. These proven designs are produced for switching low power circuits, low capacitance circuits and power circuits. 125° C insulation now available on some versions. Coils can also be designed for plate circuit.

## CONSTRUCTION:

**Magnet Frame**—Four sizes available on open type relays and three sizes on hermetically sealed type.

**Contacts**—Cross-bar palladium welded to nickel silver springs or button contacts on Beryllium copper springs.

**Terminals and Mountings**—Glass headers provided with either solder or plug-in type terminals with many various types of mountings available. Octal type plug-in headers can be provided on the HL enclosure. Plug-in terminals to fit either 9 or 14 pin standard sockets. Maximum of 14 pins for solder connections.

## TYPICAL SPECIFICATIONS \*

Open	Maximum Coil Resistance (OHMS)	Minimum Power Requirements Per pole at 25° C (WATTS)	Maximum Contact Form With rated current at 32 V.D.C. or 115 V. A.C. (non-inductive load)	Maximum Coil Watts	Enclosed
SM	9,000	.2	4 PDT 5 Amps. or 3 Amps. 6 PST 3 Amps.	3.75	HSM
SMD-2	9,000	1.0	SPNO Parallel Contacts Make 80 Amps. Break 20 Amps. at 32 V.D.C.	3.75	HSM-D-2
SC	18,500	.16	4 PDT 5 Amps. or 3 Amps. 6 PST 3 Amps.	4.5	HPSC
SA	18,500	.14	4 PDT 5 Amps. or 3 Amps. 6 PST 3 Amps.	4.5	HLSA
SM-RF	9,000	.2	SPNO, SPDT, DPNC, SPNC, DPNO	3.75	HSM-RF HLSM-RF
SAD-2	18,500	1.0	SPNO Parallel Contacts. Make 80 Amps. Break 20 Amps. at 32 V.D.C.	4.5	HLSAD-2

\*Other ratings and specifications available.

For additional information write for Bulletin No. 1050



# R B M DIVISION

Manufacturers of Magnetic Controls and Devices / LOGANSPORT, INDIANA

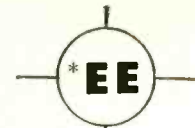

other outstanding  
\*ESSEX ENGINEERED  
production proven products

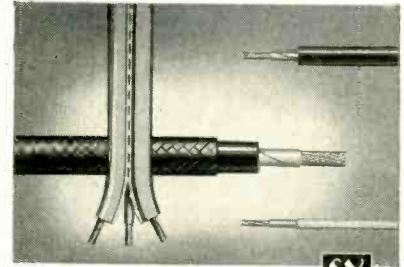

## WIRE AND CABLE

A full "Extra Test" line of lead, appliance, automotive and refrigeration wires, plus submersible pump cable and 200° C. Sil-X insulations are examples of the versatility of "Essex Engineering".

Wire and Cable Division  
Fort Wayne, Ind.

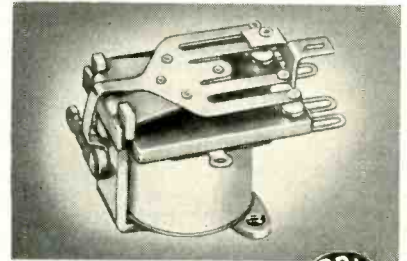

## MINIATURE RELAYS



The Type MS Miniature Sensitive Relay is ideal for any application requiring a compact, highly reliable single pole D. C. device, where a low cost solution is required because of volume usage and competitive problems. Request Bulletin No. MS-1.

R-B-M "Control" Division  
Logansport, Ind.

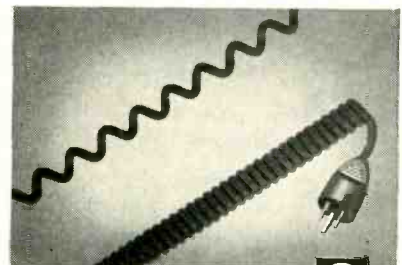

## COILED CORDS



The "spring" in Coiled Cords automatically synchronizes with moving components that are electrically powered. There are no looping, tangling cords in the way... because Coiled Cords extend and retract as needed. Write for new literature.

Cords Limited Division  
DeKalb, Ill.



ESSEX  
WIRE CORPORATION





Dr. Leslie W. Ball

Dr. Ball is a leading scientist devoted to reliability efforts and programs, and is a prominent consultant to top management in aircraft and missile industries. His independent evaluation of the "HELPR" Program follows:

In 1940 Winston Churchill stirred the conscience of American industry by his confident plea . . . "Give us the tools and we will finish the job." Our industry did respond magnificently and gave the Allied Armed Forces the tools with which the immediate job of destroying the dictatorships was finished.

But we know only too well that neither in peaceful competition nor in military defence can industry rest upon past achievements. New tasks of staggering magnitude always will arise to challenge the imagination and guts of our industrial management and to challenge the thinking and action abilities of our design, production, test, and quality control engineers.

Today, a new challenge to managers and engineers is stark in its clarity, and voracious in its demand for action. Clearly, the marriage between the science of electronics and the science of systems engineering has been, and will continue to be prolific in the procreation of complex equipments that increase the productivity of peace-time industry and radically improve the potential effectiveness of our military defence. It is evident further that many top managements have seized upon these opportunities.

In those industries that are adopting automation, and throughout our defence program, decisions have been taken to entrust the future to the abilities of complex requirements. In the case of some equipments it is merely the financial future of a single company that has been committed. In the case of military equip-

The State of the Art:

# NEW TOOLS ARE HERE TO UPGRADE RELIABILITY NOW!

## Dr. Leslie W. Ball

ment, our future in the world has been committed to the belief that complex weapon systems based on electronic equipment can be made to perform adequately in all respects.

### DRAMATIC PERFORMANCE

In the first flush of excitement over the potentialities of radically new equipments, the abilities and energies of both managers and engineers usually have been concentrated on obtaining dramatic performance. In multitudes of offices and laboratories throughout the nation, equipment performance abilities worked out on the drawing board or predicted by electronic computers have been received with enthusiasm and adopted as target. As time has brought the conversion of calculations and predictions into actual hardware, it has become painfully evident that the ominous forebodings of a small band of pioneers, now known as "Reliability Engineers," were not without substance.

Much has been written about the fundamental relationships between unreliability and complexity in electronic equipments and about the incompatibility of extracting the last ounce of high performance out of equipments that must be reliable under conditions of high environmental stress and limited maintenance skill. So, today, the managers, upon whose shoulders rests the heavy responsibility for having taken decisions to commit their companies or their defence programs to complex high performance systems, must undertake an agonizing reappraisal of their electronic equipments within these systems.

### BLUNT QUESTION

The blunt question that faces them is, "Must we retreat to simpler, lower performance devices, or is there an immediate line of reliability upgrading action whose cost is within reason and whose effectiveness is beyond question?"

The answer to this vital question is not to be found in academic discussions of the abstractions of reliability nor in the ivory towers of higher mathematics. It is to be found in the testing and analytical laboratories where countless analyses have been made of equipments that have failed in service or in which failure has been produced by simulation in the laboratory of service stresses.

*The answer to the question "Must we retreat?" is a confident "No, we need not retreat. There is a path to electronic equipment reliability whose cost is within reason and whose effectiveness can be assured."*

To define the path to reliability specifically and clearly, we must first express the underlying causes of equipment unreliability in engineering management terms.

Both technological advances and management action have provided the systems engineers with the tools that they need to work out complex system performance, and to generate sound preliminary designs. Unfortunately, in the electronic industry the detail designer, the production engineer, the test engineer, and the quality control engineer have not been provided with all the tools that they need to follow through from a preliminary system

# State of the Art: NEW TOOLS ARE

design to delivery of a completely reliable finished product.

A FUNDAMENTAL CAUSE OF ELECTRONIC UNRELIABILITY IN TODAY'S ELECTRONIC EQUIPMENT IS THAT DESIGNERS ARE REQUIRED TO DESIGN CIRCUITS, QUALITY CONTROL ENGINEERS ARE REQUIRED TO CONTROL PERFORMANCE, AND TEST ENGINEERS ARE REQUIRED TO PLAN EVALUATION PROGRAMS WITHOUT MUCH OF THE BASIC HANDBOOK TYPE OF DATA ON WHICH THE RELIABILITY OF ALL OTHER TYPES OF ENGINEERING EQUIPMENT DEPENDS.

To illustrate this deficiency, suppose that the management of an aircraft company had made excellent provision to obtain systems engineering and a preliminary design for a new super performance complex rocket-powered plane and then assigned the task of detail design, quality control and test planning to their staff. But, with the provision that they would be denied anything approaching complete knowledge of the strength, endurance and failure characteristics of the materials and components of which the system was to be built.

The opinion of their customer and of other managers would be that this was a preposterous way to manage an engineering project, and unreliability in the product would be a foregone conclusion. *And yet, inadequacy in the organized knowledge of strength, endurance and failure of component parts is characteristic of almost all military and industrial electronic equipment projects.*

Management thinking about the provisions that they must make for providing their staffs with adequate knowledge of electronic component parts can be helped greatly by the following definition: "Any equipment component or part is inherently unreliable until every mode of failure is known, understood, measured and controlled."\*

Throughout the mechanical engineering industries the truth and significance of this definition is accepted as self evident. Moreover, large quantities of organized knowledge on understanding, measurement and control of every mode of failure of mechanical parts are contained in engineering handbooks. For example, in the case of reciprocating machinery unreliability caused by the phenomena of fatigue is no longer tolerated because an understanding of the design and manufacturing factors that can per-

mit fatigue to occur, together with tables and curves showing the relationship between stress level and number of cycles to failure and established quality control procedures, are all available in the form of handbook data.

## URGENT NEED

The problem of the component part failures that cause unreliability in electronic equipment is analogous to fatigue failure in metal parts, but there are at least two important differences, each of which makes the need for handbook data more urgent.

First, the stresses imposed upon the part are more diverse. That is, the effects of placing an electronic component part in a complex circuit require rather more analysis and more types of data than required for the determination of the stresses on a part in a mechanical structure.

Second, the number of modes of failure resulting from variety in the materials and methods of construction of electronic parts are much greater than for purely structural parts that can fail only by such well known phenomena as tensile fracture.

Third, whereas mechanical parts are characterized by long service and laboratory testing histories that have resulted in well organized and widely published handbook data, electronic parts have either not existed long enough or have not been studied intensively enough for such handbook data to be available.

The contrast between disciplines in electronic and mechanical engineering is obvious. In the electronic industry, management and engineers must undertake immediate and imaginative action to generate and distribute handbook type data. This would embrace the understanding, measurement and control of all types of electronic component parts whose failure contributes to unreliability.

We may assume that this statement is beyond question, and the real issue for management and engineers to decide is "WHAT IS THE FASTEST, MOST ECONOMICAL AND MOST EFFECTIVE METHOD TO GENERATE HANDBOOK DATA?" The possibility of each company being dependent only on its own component part testing programs must be ruled out, because the cost is prohibitive and the time taken to get the job done on limited testing facilities would be hopelessly excessive.

## IMPORTANT PECULIARITY

In this regard a very important peculiarity of electronic component parts must be recognized. This peculiarity may be called "the existence of minority groups

in the manufactured population." For example, consider a population of one thousand capacitors produced by a particular manufacturer. From the point of view of performance, all these capacitors will belong to a single homogeneous population, but, from the point of view of reliability, the population is by no means homogeneous.

If the thousand capacitors were subjected to circuit stresses and to external environmental stresses, some of them would become "early failures" and others would become "random failures." Suppose that out of the thousand, ten are potentially early failures and another forty are potentially random failures. If a test sample of, say, six capacitors were chosen from among the nine hundred and fifty that will fail by wear out, the results of this test program would be completely useless and dangerously misleading because they would tell nothing of the unreliability that would be caused by the ten early and the forty random failures.

It follows that it is vitally important to subject the whole population of one thousand capacitors to an ambitious test program that includes statistical design of experiments, detailed analysis of failures, and statistical interpretation of results.

Even in equipments where a high failure rate of, say, one part in a thousand can be tolerated, the test sample size should consist of several hundred parts. In equipments where failure rates of only one in a hundred thousand can be tolerated, the sample size and consequently, the cost of the test program must be increased correspondingly.

IT IS THEREFORE APPARENT THAT EVEN LARGE ELECTRONIC EQUIPMENT COMPANIES CANNOT AFFORD TO UNDERTAKE TEST PROGRAMS TO GENERATE ALL THE KNOWLEDGE OF ELECTRONIC COMPONENT PARTS THAT THEY REQUIRE, AND THAT THEY MUST SUPPLEMENT THEIR OWN WORK BY PARTICIPATION IN A PROGRAM SUBSCRIBED TO BY A LARGE GROUP OF COMPANIES.

A second cost aspect is that the recording of test data by technicians reading indicating instruments is incompatible with the enormous number of readings that must be made to generate the amount and accuracy of data required for handbook purposes. Consequently, the principle of automation must be applied to the recording of data during component part testing programs.

Both the above cost considerations lead to the conclusion that electronic equipment manufacturers can reduce the cost of reliability programs radically by sub-

\*"Management Use of Laboratory Testing to Achieve Reliability." A Paper presented to the University of California at Los Angeles Engineering Management Symposium in January 1955 by Leslie W. Ball.



# HERE TO UPGRADE RELIABILITY NOW!

scription to testing programs performed in a competent laboratory, where sample sizes of thousands can be handled and where data can be recorded automatically.

## STEADY FLOW

The general relationship between such a laboratory and the subscriber to such a program must go far beyond the mere provision of testing facilities and automation instrumentation. The laboratory must provide the subscriber with a *steady flow* of organized knowledge that makes it possible for the subscriber to diffuse throughout his whole organization "knowledge, understanding, measurement and control" of all the modes of failure of the electronic component parts used in the company's products.

While the above statement summarizes the service that must be rendered and leaves no doubt that the benefits to be gained by subscription to this laboratory program will far exceed the cost to the subscriber, and while the brochure offered by the "HELPR" program provides detailed information to the individual engineer, it is to be expected that the subscriber's management will want a more specific summary of what will come out of the testing program, and of the identity of the departments within his organization that will use the output, and of the ways in which they will use it.

On the basis of work already done in similar, but much more restricted testing programs, the following five specific types of output and six specific types of application by subscriber's personnel may be identified.

## FAILURE RATE CURVE — CIRCUIT STRESS

For each type of component part it is generally recognized that some particular circuit stress is of primary importance in regard to failure rate and reliability. For example, in the case of capacitors, the voltage across the capacitor is accepted as the primary circuit stress. Test programs for each type of part will result in a family of curves in which failure rate is the ordinate, time is the abscissa, and one curve is plotted for each value of the primary circuit stress.

In general, the curves will have a characteristic shape which in many cases will be the familiar three part curve showing early, random and wearout failures. The corresponding time intervals may be called the "infant mortality screening period," "service period" and "over-age period." Quite apart from numerical values of the failure rates, knowledge of the shape of these curves and of the duration of the infant mortality screening, service and over-age periods are vital to intelligent decisions on quality control and preventative maintenance requirements.

## RELIABILITY INDICES

For those component parts that show a "random" failure rate in the service period, a single value for failure rate index may be established. In other cases an average value in the service range may be selected as characteristic of the part. All these values could be prepared in summary tabulated form suitable for use as reliability indices during the precalculation of the reliability to be expected from any new type of electronic equipment.

## FAILURE RATE CURVES — ENVIRONMENTAL STRESS

It is well known that the failure rate produced by a primary circuit stress can be greatly modified by the environment in which the part operates. For example, in the case of capacitors the ambient temperature will have a major effect upon the failure rates produced at any given voltage.

It is recognized further that, when environmental stress becomes severe, entirely new modes of failure not directly related to the circuit stress are produced and that these new modes of failure will have their own characteristic failure rates. The test program should produce curves showing both the modification of circuit stress failure rates with environments, such as temperature of vibration intensity, and other curves showing failure rates produced by the environment in the absence of circuit stress.

## MODE OF FAILURE ANALYSES

If the laboratory's service to the subscriber finished with the production and mathematical analysis of failures, the most constructive and universally applicable reliability upgrading information would be lost. The laboratory service should include detailed disassembly and analysis of the physical, chemical and mechanical modes of failure of each type of component part. The results and interpretation of these analyses will be available to the subscriber and to the manufacturer of the part.

## CORRELATION OF FAILURE RATES WITH DESK ANALYSES

Obviously, test programs must be performed upon component parts bought from particular vendors, and, consequently, test results presented under the above four categories would be specific to each vendor. However, it would be chronically wasteful to limit the output of the test program simply to the products of the vendor supplying test items.

By careful analysis of the design characteristics of the parts, combined with knowledge of the manufacturing processes and quality controls used by the vendor, it is possible to establish extreme-

ly valuable correlations between failure rates and design and manufacturing factors. These correlations are universally applicable to the products of all vendors. The laboratory should seek to establish such correlations and will present the results in the form of technical reports to the subscribers.

## USE OF TEST RESULTS BY SUBSCRIBER'S PURCHASING DEPARTMENT

The results of the test programs will be of direct benefit to the purchasing departments in the selection of component part vendors. Even when a particular vendor's parts have not been included in the program, the subscriber's purchasing department would be able to make use of the test results in evaluating the materials and process controls used by the supplier.

## BY SUBSCRIBER'S PRELIMINARY DESIGN DEPARTMENT

Whenever a new system or equipment is offered in a preliminary design proposal, it is a good management practice to require a precalculation of the expected reliability of the equipment if it is to be built from state of the art component parts. Although at this time the exact number of parts and the circuit stresses that will be imposed upon them are unknown, certain assumptions can be made based on similarities between previous equipment and proposed equipment. By combining these assumptions with reliability indices for the component parts, a precalculation can be made.

## BY SUBSCRIBER'S DESIGNERS

During the design phase, decisions must be made on the general degree of part derating and on the amount of money, space and weight that will be allowed for reduction of environmental stresses. The test program would provide specific numerical values to guide both the amount of action needed and to indicate which changes will be most effective.

## BY SUBSCRIBER'S PARTS APPLICATION ENGINEERS

It is well known that the failure rate for a given part depends greatly on the circuit stresses imposed upon it and that, in some cases, circuit stresses that are of little importance to the performance of the equipment are of major importance to its reliability. The test program should provide specific data for identifying the nature and magnitude of circuit stresses that must be considered by the part application engineer in determining the suitability of a particular part for a particular application.

*Advertisement*

### BY SUBSCRIBER'S TEST ENGINEERS

Each electronic equipment manufacturer must make use of a great deal of testing in his own plant for both design and quality control purposes. For example, in the case of custom parts, such as special potentiometers, the subscriber must write his own specification and specify his own test methods. The results of the "HELPR" laboratory program would be valuable in indicating which tests are likely to be most effective for a particular type of component, and to give some significance to them when the size of the test sample has to be very small.

### BY SUBSCRIBER'S QUALITY CONTROL ENGINEERS

It is generally true that the reliability of electronic equipment can be greatly improved by much more widespread use of non-destructive testing methods on the manufacturer's receiving inspection line and by cautious use of what is now called production environmental testing. The "HELPR" laboratory program would pro-

vide clear indications of which types of non-destructive testing can be most effective and information that should be sought by non-destructive methods.

In the case of production environmental testing, if this is done without the guidance of comprehensive knowledge of the shape of the failure rate curves and the duration of the infant mortality period, there is a very real danger that the environments will increase rather than decrease the unreliability of the equipment. However, with the type of information that the central laboratory program would provide, major improvements in reliability from carefully selected and controlled production environmental tests can be confidently expected.

\* \* \*

The net result of all the above outputs from a central laboratory program and the application of these results by the subscribers could be momentous. Whereas, without a major program for generating handbook data on component parts, the electronic industry may have to retreat from the degree of performance and sophistication in designs now going into

production. *With the proposed program, the horizons for the electronic industry become unlimited.*

Certainly in the case of industrial automation, the difference between a record of unreliability and a record of reliability will not only be a major factor in the success or failure of individual companies, but it will be the difference between a vast new surge of growth for the electronic industry as a whole, and a rapid saturation and ensuing stagnation if the market is limited to only those applications that can tolerate unreliability.

In summary, the new branch of the engineering profession that we call reliability engineers have done an outstanding job in recognizing the nature of the problem, in analyzing its causes, and in delineating the path that must be taken to overcome the problem.

*It is now up to the managers and the responsible engineers throughout the electronic industry to decide whether the American Electronic Industry will advance rapidly and lead the world in producing successful complex equipment, or whether we will hesitate and fall upon the burden of unreliability.*

---

## The "HELPR" PROGRAM

WIRE OR WRITE TODAY for the 52-page book, "The Handbook of Electronic Parts Reliability Program"—A Detailed, Systematic Approach. There is no obligation, just ask for the "HELPR" Book. Address:

General Manager,  
INLAND TESTING LABORATORIES,  
Cook Technological Center,  
Morton Grove, Illinois

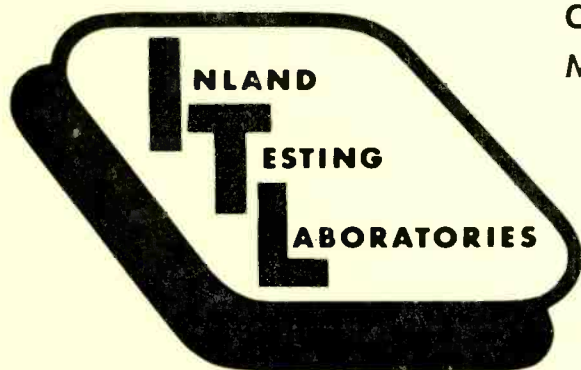

A DIVISION OF COOK ELECTRIC COMPANY  
Chicago, Illinois



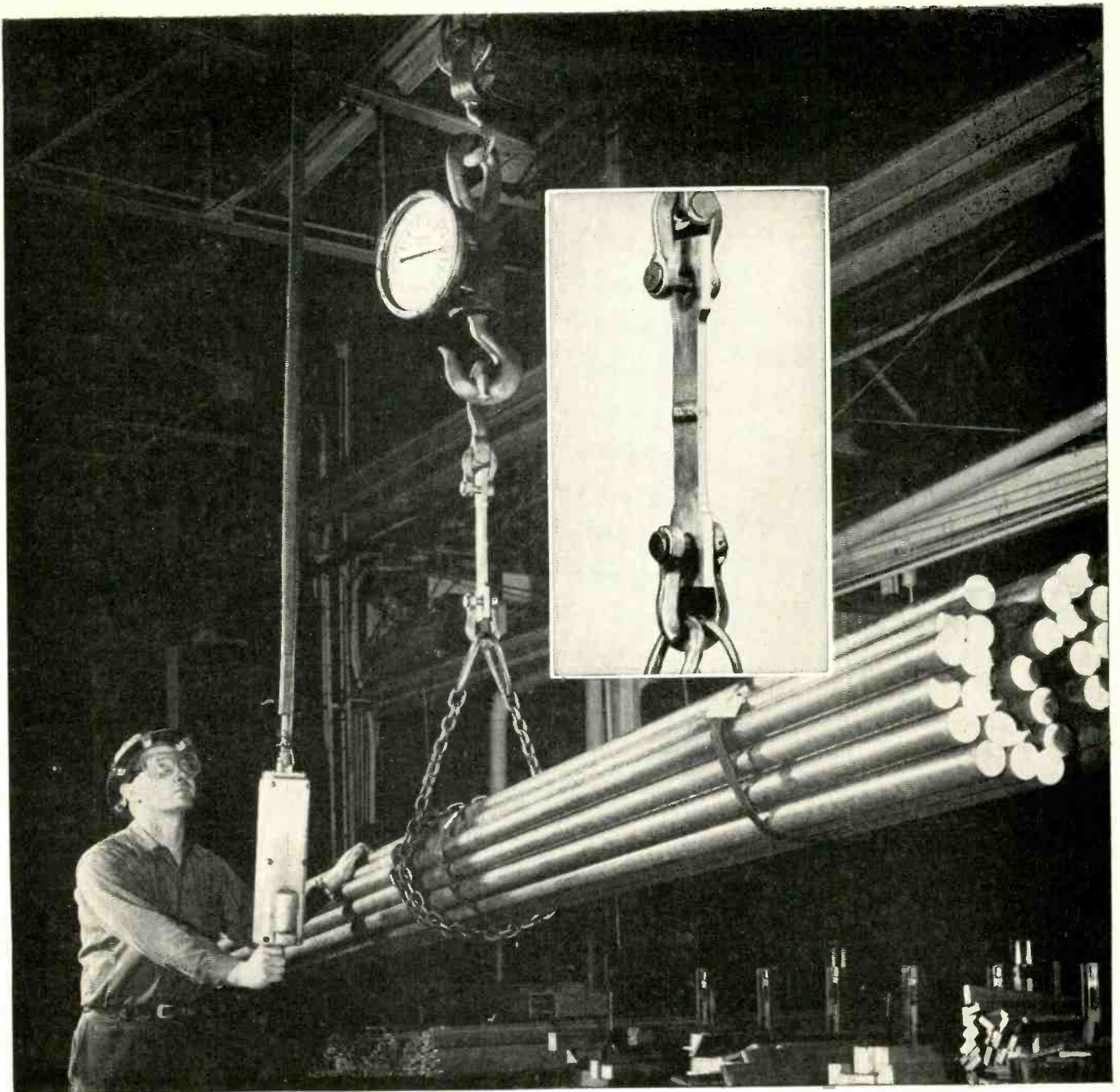

## Weld Strength! Magnesium has 95% weld efficiency

In the picture above, a small arc-welded magnesium bar is supporting a load of four tons. This is one example of what we mean by "strong" when we say magnesium is light but strong. Its weld efficiency, the relationship between the strength of the parent metal and a welded joint, is very high. AZ31B magnesium alloy plate, tensile strength 35,000 psi, has a welded joint tensile strength of 33,000 psi, or a weld efficiency of 95%!

Magnesium can be arc welded, gas welded, or welded by

electric resistance (spot, seam or flash). Magnesium plate  $\frac{1}{2}$ " thick can be joined by arc welding in one pass. It can also be readily joined by most any other method: riveting, bolting, screwing, adhesive bonding and self-fastening devices.

These facts spotlight just one of the many reasons magnesium does a better job in many fabricated metal products. For more information, contact your nearest Dow sales office, or write to us. THE DOW CHEMICAL COMPANY, Magnesium Department, Midland, Michigan, Dept. MA1403M.

YOU CAN DEPEND ON

**DOW**



# ELECTRON TUBES FOR SURVIVAL

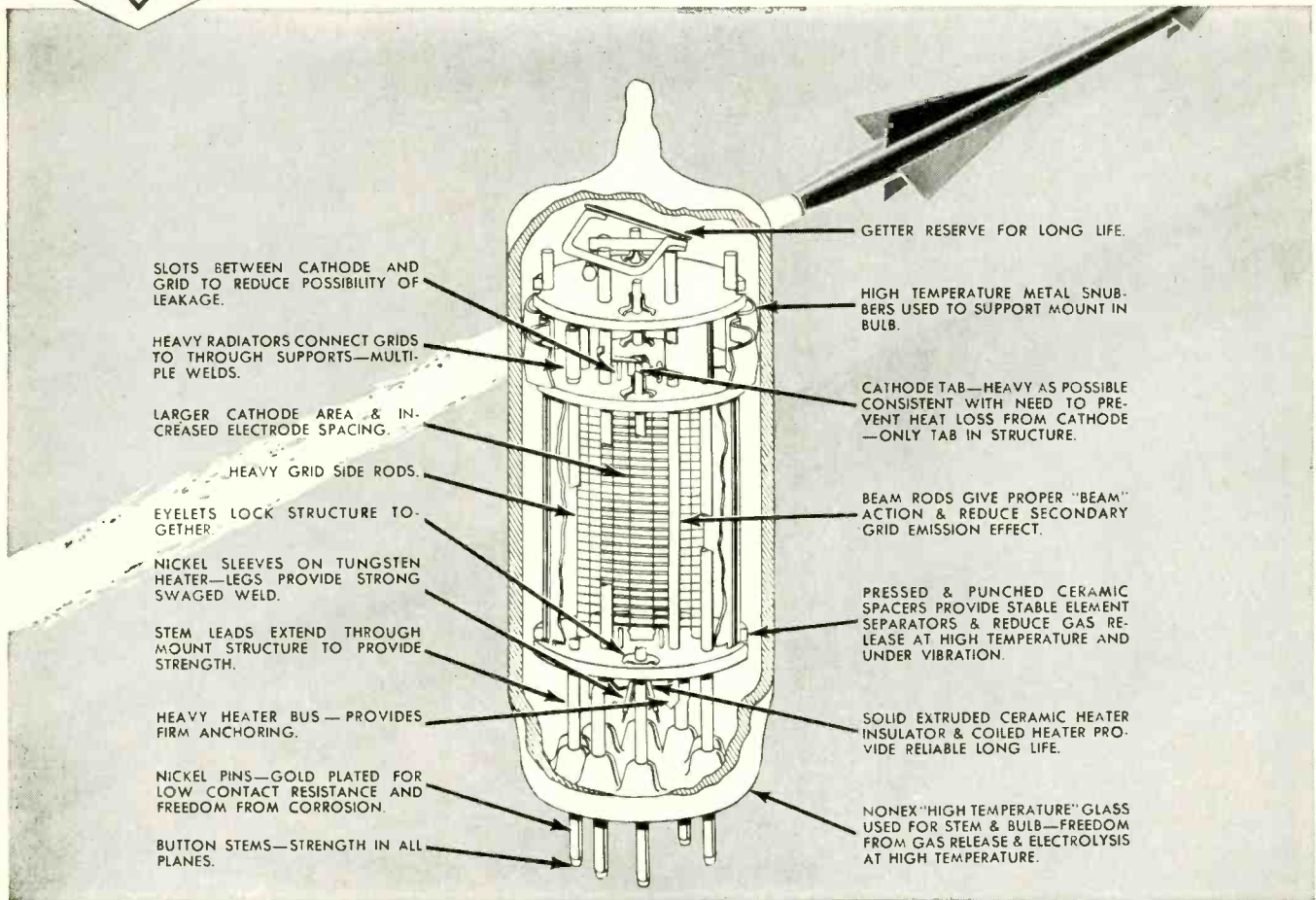

## WHY BENDIX\* HY-G-300 ELECTRON TUBES ARE BEST FOR EXTREME SHOCK, VIBRATION AND TEMPERATURES!

From the standpoint of design features (see above), these reliable hard glass tubes offer the superior quality needed to survive today's severe environmental demands.

Specifically, Bendix HY-G-300's are designed to withstand the following environmental conditions—bulb temperatures up to 300° C; vibration up to 20G's over the range of 5-2000 cycles; and shock of 200G's having 20-millisecond duration.

For full information about the HY-G-300 line . . . the surest answer to electron tube applications in jet aircraft, missiles and rockets . . . write RED BANK DIVISION, BENDIX AVIATION CORPORATION, EATONTOWN, NEW JERSEY.

West Coast Sales and Service: 117 E. Providencia, Burbank, Calif. \* Export Sales and Service: Bendix International Division, 205 E. 42nd St., New York 17, N. Y. \* Canadian Affiliate: Aviation Electric, Ltd., P. O. Box 6102, Montreal, Que.

\*TRADEMARK



### TUBES ARE AVAILABLE FROM STOCK

Bulb Size	DbI. Triodes Volt Amp.	R F. Pentodes	Gate Pentodes	Rectifiers FullWave	Beam Power	Power Triodes Passing
T-12	—	—	—	—	—	6080WB 6082A
T-11	—	—	—	—	6384 6889	—
T-9	—	—	—	6853	—	—
T-6½	6851 6854 6900	6582A	6486A	6754	6094	6877 6900

Retma Type No.	Retrofit For	Generic Type	E <sub>f</sub>	I <sub>f</sub>	Bulb	Bendix Type No.
6080WB	6080 6080WA	6080	6.3	2.5	T-12	TE-46
6094	—	6A05-6005	6.3	0.6	T-6½	TE-18
6853	6106 5Y3	5Y3	5.0	1.7	T-9	TE-45
6384	6AR6 6098	6AR6	6.3	1.2	T-11	TE-27
6854	6385	2051 5670	6.3	0.5	T-6½	TE-47
6486A	6486	6AS6	6.3	0.25	T-6½	TE-43
6582A	6582	6AK5	6.3	0.25	T-6½	TE-44
6754	412A	—	6.3	1.0	T-6½	TE-36
6851	5751	—	6.3	0.5	T-6½	TE-42
6877	—	Half of 6080	6.3	0.8	T-6½	TE-48
6900	5687	5687	6.3	0.9	T-6½	TE-54
6889	—	—	6.3	1.2	T-11	TE-52
6082A	6082	6082	26.5	0.6	T-12	TE-55

Red Bank Division







**At Boeing,  
Seattle, Washington**

MIL-W-5086 low tension airframe wire is used in low voltage circuits throughout the B-52 Intercontinental Jet Bomber.

**At Douglas,  
El Segundo, California**

MIL-W-5274A hook-up wire is used in the electrical, radio and radar components of the A4D Skyhawk and F4D Skyray.



**At Western Electric,  
Burlington, N. Carolina**

MIL-W-76A is used in the computer section of the Nike Ajax missile, wiring the input, calculator and output sections.



**At Raytheon,  
Waltham, Massachusetts**

MIL-W-16878B high-temperature hook-up wire is used in *classified* airborne navigation and bombing radars.

CLASSIFIED

**At Chance-Vought,  
Dallas, Texas**

MIL-C-7078A shielded air frame wire is used near radio and radar apparatus to assure distortion-free operation of electronic equipment on the F7U-3 fighters.



**At Burgess Battery,  
Freeport, Illinois**

JAN-C-76 general purpose hook-up wire is used to interconnect cells of dry batteries for portable military equipment.

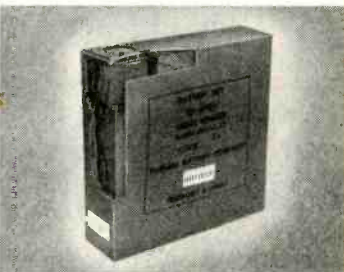

**At North American  
Aviation, L. A., Calif.**

MIL-C-17B coaxial cable is used in high frequency radio and radar circuits on the F100 Super Sabre fighters.



**FOR  
MILITARY  
SPEC WIRE  
AND CABLE**

**leading manufacturers  
choose Brand quality,  
Brand service**

Turbo-Brand wires are manufactured under a program of scientific quality control to exceed the rigid requirements of these and other manufacturers the world over.

Available as single conductors or as custom-designed multi-conductor cables, Turbo-Brand cable may be specified to incorporate any number of conductors, any combination of wire types, and any predetermined lay-up pattern.

Your inquiry is invited.

**WILLIAM BRAND  
& COMPANY, INC.**

WILLIMANTIC 3, CONNECTICUT

Electrical and Electronic Wires and Cables • Harnesses and Cable Assemblies • Plastic and Coated Insulating Tubings • Identification Markers

# TOUGH THERMOSTATS SAY "RELAYS FOR SISSIES"

## Snap-Action Thermoswitch Units Boss Big Loads Without 'Em

### "Relays? Who needs 'em?"

ASHLAND, MASS. — If you want to control good-size electrical loads with a precision thermostat, and you don't want to bother with relays, Fenwal has just the thing.

Fenwal has two series of snap-action Thermoswitch® units, more than twelve models, all based on the same idea — and they don't need relays.

The idea is this:

A liquid responds to temperature changes by expanding or contracting, and moves a bellows assembly. The bellows assembly works a snap-switch with a push-rod, making or breaking a circuit.

This arrangement will let you control electrical loads up to 20 amps, 115-250 volts A.C., or 10 amps, 125 volts, D.C., without relays, and with a high degree of accuracy.

Fenwal's two series of these remarkable units are called the 20000 and the 22000. The first has only one snap-switch, and the second has two. Two snap-switches and one unit, of course, give you compact control for two-stage heating or cooling.

As for adjusting temperatures — your own men can do it simply in the field. An easy-to-get-at set screw on each switch does the trick. On the double switch models, each switch is set independently.

As for accuracy and speed of response — the units control to within  $\pm 2^\circ$  F.

As for cost — Fenwal has designed both series of snap-action THERMOSWITCH controls along "building block" lines to save you money. That is, Fenwal can assemble specialized units for you from a selection of standardized temperature ranges, head types, "application-rated" snap-switches, and mounting styles.

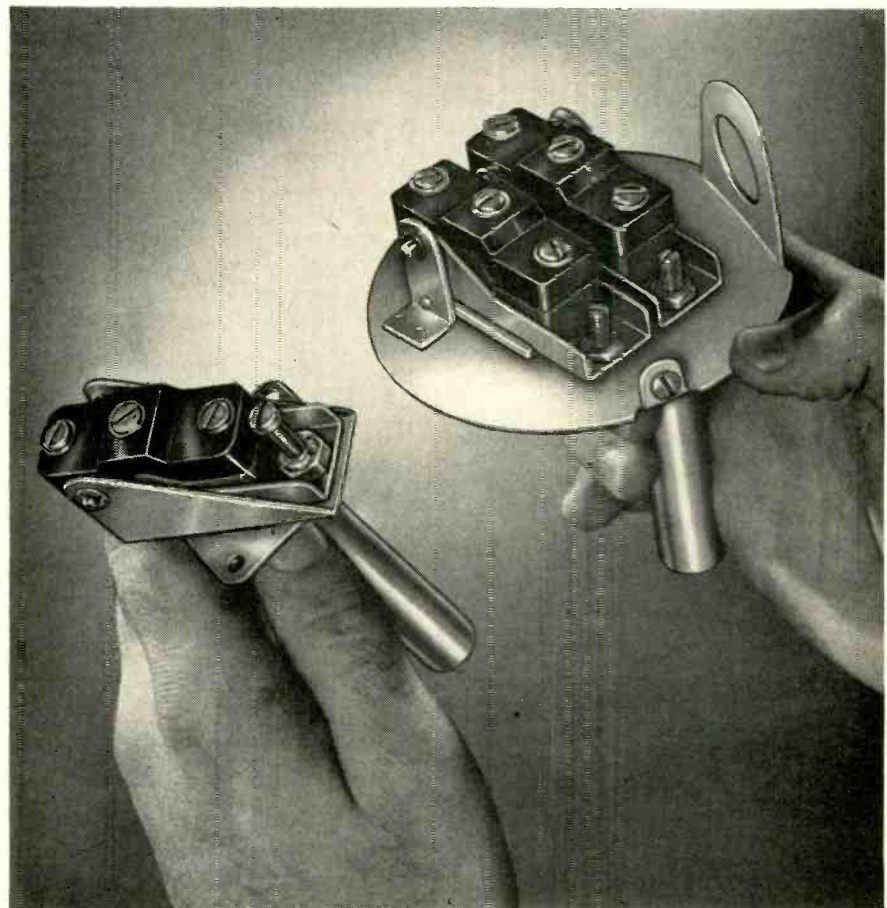

THESE TWO FENWAL SNAP-ACTION THERMOSWITCH UNITS — control loads up to 20 amps, 115-250 volts A.C., or 10 amps, 125 volts D.C. — without relays. These are only two of the twelve models available from Fenwal's Series 20000 (one-switch) and Series 22000 (two-switch) snap-action units.

The temperature ranges you can choose extend from  $-75^\circ\text{F}$ . to  $+300^\circ\text{F}$ .

If you choose these controls for your application, you will not be choosing an untried product. You will be joining a large group of satisfied users who have put them to work in such varied equipment as air conditioners, hot-drink vending machines, laundry equipment, and dishwashers.

Designers — write for details on the Fenwal Series 20000 and 22000

snap-action THERMOSWITCH units. You will want those details at your fingertips. Write to **Fenwal Incorporated, 208 Pleasant Street, Ashland, Massachusetts.**



**CONTROLS TEMPERATURE  
... PRECISELY**



# Cut assembly costs in half with larger printed circuits

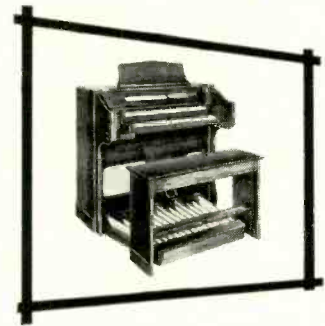

The dependable quality of Formica copper clads has reduced the risk of costly rejects. This enables electronics manufacturers to design the larger circuits that reduce labor costs as much as 50%.

Such sensational labor savings have actually been demonstrated by Allen Organ Co., Macungie, Pa., manufacturers of electronic organs. Allen officials also report increased production and simplified field service of organs have resulted from the use of higher quality Formica copper clad laminates.

The quality that has made larger circuits practical is the Formica development of cold punching and better machineability and higher insulation resistance.

Why not cut your assembly costs with larger circuits? You can do it with complete confidence with Formica copper clad laminates. And remember, Formica gives you the widest choice of base laminates, including over 12 grades made of paper and nylon, glass and cotton cloth . . . impregnated with epoxy, phenolic and melamine resins.

For complete information, send today for Copper Clad Technical Data, form 688. Formica Corporation, subsidiary of America Cyanamid, 4530-7 Spring Grove Ave., Cincinnati 32, Ohio.

## ● Circuits by the yard

Larger circuits reduce wiring time from 8 hours to 4. Made from Formica XXXP-36, the cold punching copper clad that assures greater accuracy through dimensional stability.



Subsidiary of



**Save your engineering time** — use Formica 4, the complete laminated plastics service.

FI-1426

1. Application engineering
2. Research
3. Fabricating
4. Customer stock service

Compatible Single-Sideband Transmitter Adapter, developed by Kahn Research Laboratories for Station WMGM, uses Hycon Filter Model 100 KUC.

Hycon Filter Model 100 KUC  
Shown 1/2 size



Accurate phase and frequency response for Single-Sideband Transmission . . .

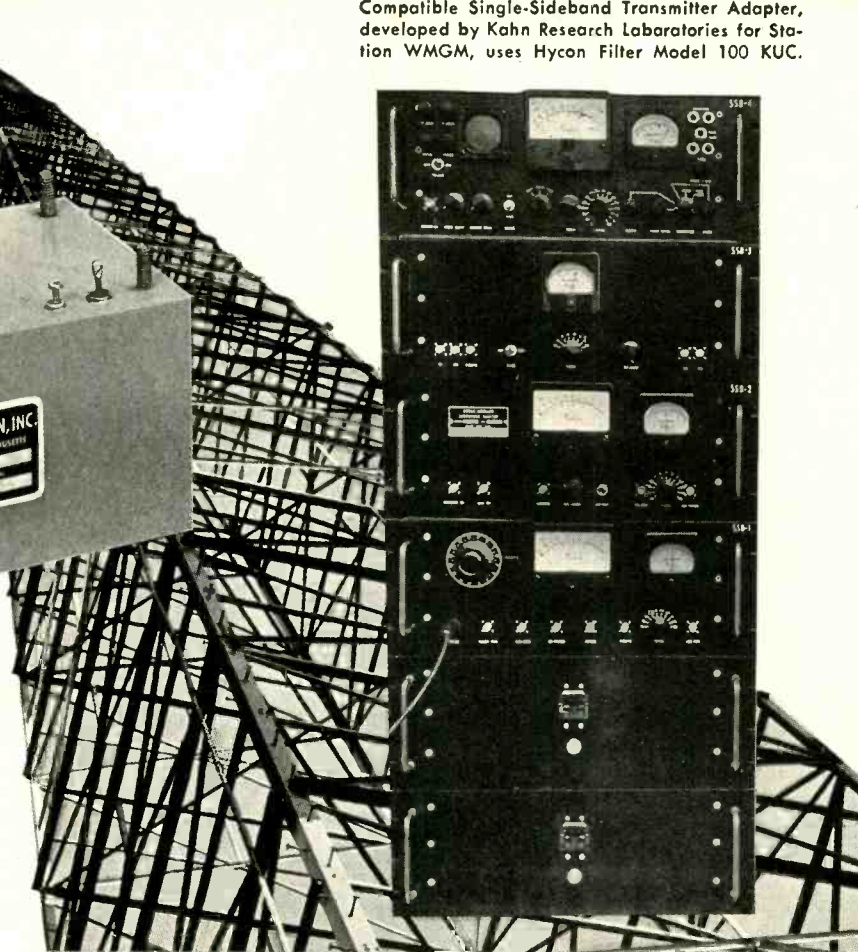

Radio Tower of Broadcast Station WMGM (50,000 watts)

## another problem solved by HYCON FILTERS

The first domestic broadcast installation of the Compatible Single-Sideband Modulation Method has recently been completed by Broadcast Station WMGM of New York City on an experimental basis. Advantages of this system are improved fidelity, improved range in the presence of co-channel interference, resistance

to fading and reduction in spectrum space. Because of their ability to meet the stringent requirements for the SSB frequency selective networks, Hycon Filters were chosen for this installation by Kahn Research Laboratories, designers of the CSSB Transmitter Adapter.

Whether your selectivity problems are in transmission or reception, AM or FM, mobile or fixed equipment, Hycon quartz crystal Filters offer you these advantages: **LOW COST** — standard models; **LOW DISTORTION** — pass-band uniformity within  $\pm 1/2$  db; **HIGH STABILITY** — inherent in crystal resonators, also freedom from microphonic behavior; **ZERO MAINTENANCE** — hermetically sealed, requiring no realignment or readjustment. Hycon Eastern, Inc. can assist you in the selection of filter characteristics best suited to your needs. Write for Crystal Filter Bulletin.

### ELECTRICAL SPECIFICATIONS (Model 100 KUC)

Carrier Frequency: 100 KC  
Attenuation at carrier +300 cps: 2 db maximum  
Attenuation at carrier +6000 cps: 2 db maximum  
Attenuation at carrier -300 cps: 60 db minimum  
Insertion Loss: 10 db maximum  
Passband Response Variation:  $\pm 1/2$  db  
Impedance: 8200 ohms  
Dimensions:  $5\frac{3}{8}$ " x 3" x  $2\frac{3}{8}$ "

ALSO AVAILABLE: Model 100 KLC—Lower Sideband  
Model 100 KPA—Carrier Selection

"Bridging the Gap Between Science and Technology through Electronics"

WESCON SHOW  
Booth 816



**HYCON EASTERN, INC.**

75 Cambridge Parkway Dept. A-8 Cambridge 42, Mass.

Affiliated with HYCON MFG. COMPANY, Pasadena, California

Manufacturers of: Crystal Filters, Ultra Stable Oscillators, and Magnetic Tape Indexing and Search Units



announcing

# GEC VIDICON

a superior television pickup tube



*this tube  
may be operated  
or carried in  
any position*

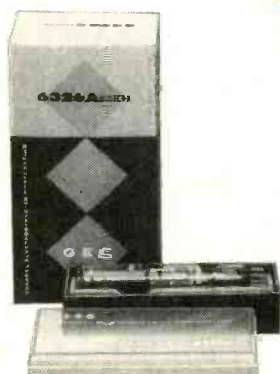

*Your GEC Vidicons will reach  
you in factory condition because  
of GEC-built shockproof packaging.*

Now you can get sturdy GEC Vidicons built for hard handling and usage. Also, you are assured exceptionally long service life by precision manufacture under controlled conditions in GEC's ultra-modern new plant. Both the Industrial 6198A and Broadcasting 6326A types (improved design with side tips eliminated) are available for immediate delivery. See your parts distributor or write directly to GEC.

*Write for new data sheet . . .*



**GENERAL ELECTRODYNAMICS CORPORATION**

4430 FOREST LANE | GARLAND, TEXAS

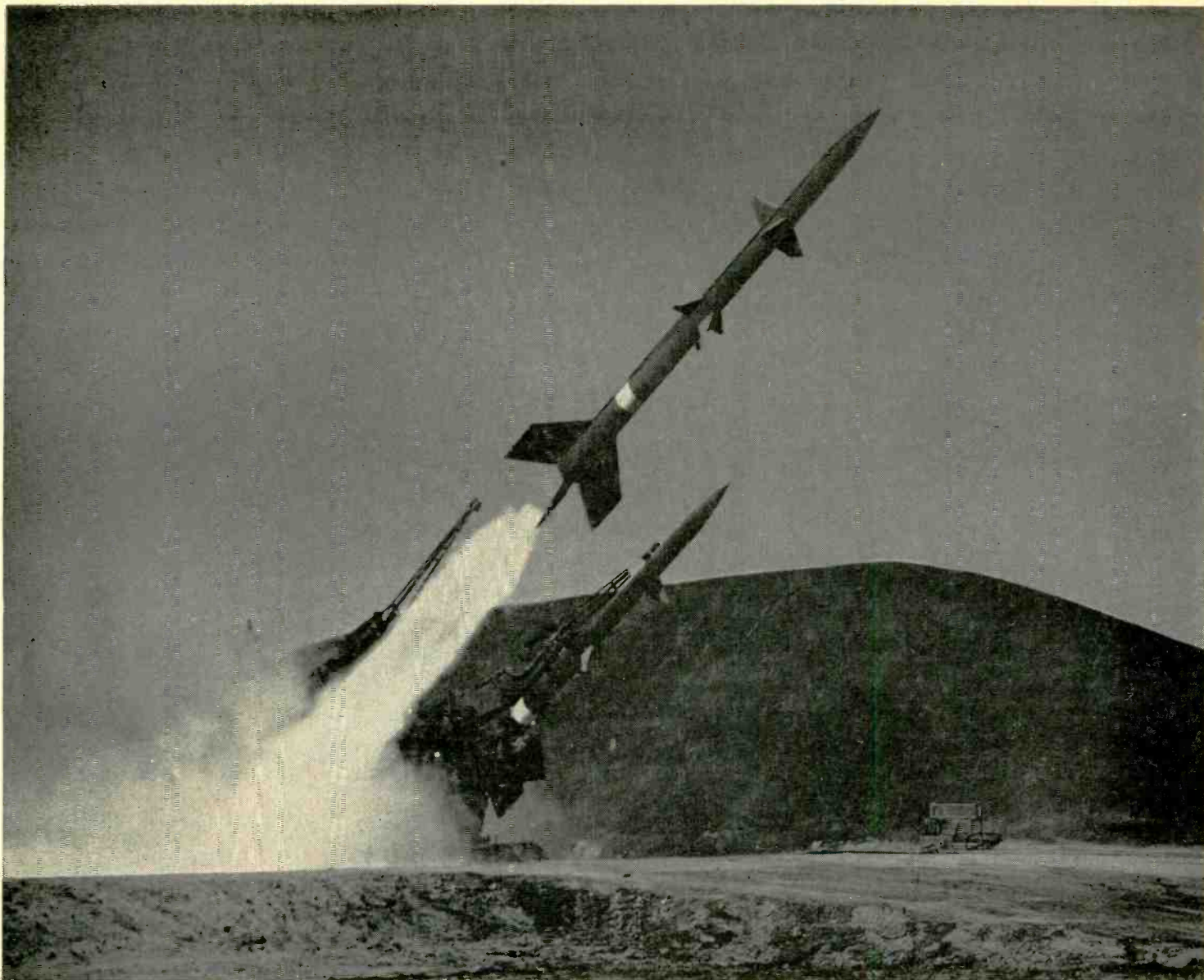

PHOTO COURTESY OF U.S. NAVY

# Where there must be no slipups there will be no slipups — if you depend on CTC

Looking for reliability?

CTC guarantees its components unconditionally — in any quantity from one to millions. CTC quality control includes material certification, step-by-step inspection in production, and finally rigid inspection of finished product. There is reliability for you.

For samples, specifications, and prices, write to Sales Engineering Department, Cambridge Thermionic

Corporation, 437 Concord Avenue, Cambridge 38, Mass. West Coast stocks maintained by E. V. Roberts

& Associates, 5068 West Washington Blvd., Los Angeles 16 and 988 Market St., San Francisco, Calif.

## CTC

**CAMBRIDGE THERMIONIC CORPORATION**

*makers of guaranteed electronic components  
custom or standard*



See CTC's Guaranteed Components on Display at Booth 1820, 1957 Wescon Show, San Francisco Cow Palace, August 20th to 23



# Ten families of CTC quality components — guaranteed unconditionally in any quantity

## CTC QUALITY SHIELDED COIL FORMS

Miniaturized. Highly shock resistant. Mechanically enclosed, completely shielded for maximum reliability.

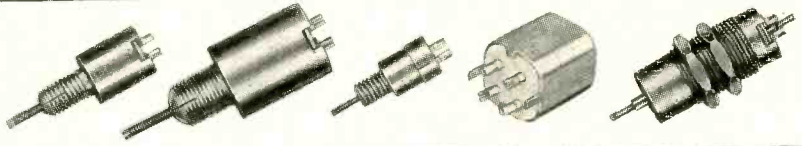

## CTC QUALITY CAPACITORS

Miniaturized Variable Ceramic Capacitors that outperform much bigger capacitors. (Extreme right): Stand-Off Capacitors with ceramic dielectric. Rugged R-F by-pass capacitors for high quality equipment. Shock-, vibration-, humidity-resistant.

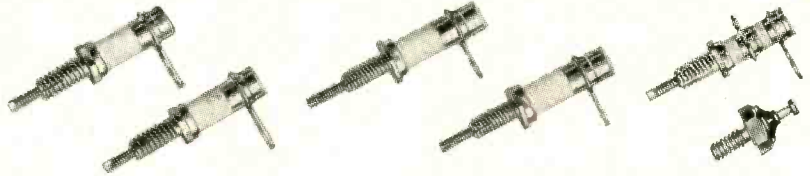

## CTC QUALITY WOUND COILS IN STANDARD VALUES

Precision wound on slug-tuned ceramic coil forms, with silicone Fibreglas collars and mounting hardware. Available in bulk or in kit form (illustrated).



## CTC QUALITY KITS

Design your electronic equipment around standard components, using four convenient CTC kits: Coil Form Kit, Coil Kit, Choke Kit, Solder Terminal Kit (illustrated).

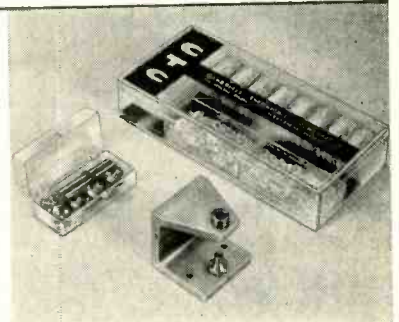

## CTC QUALITY DIODE CLIPS

Seven different types, including spring-loaded units primarily for holding fragile diode pigtail leads from .005" to .085" in diameter. CTC also offers lines of quality battery clips and miniature plugs and jacks.

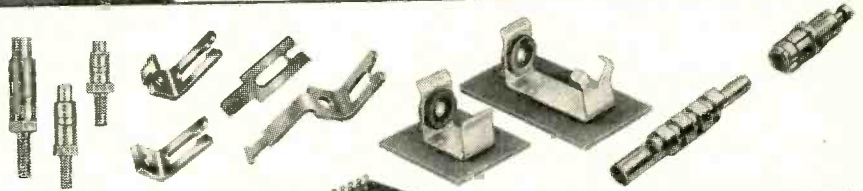

## CTC QUALITY TERMINAL BOARDS

Custom-made, standard all-sets, standard ceramics. Variety of materials available — paper, cloth, nylon, glass laminates — phenolic, melamine, epoxy, silicone resins. Moisture — and fungus-proofed.

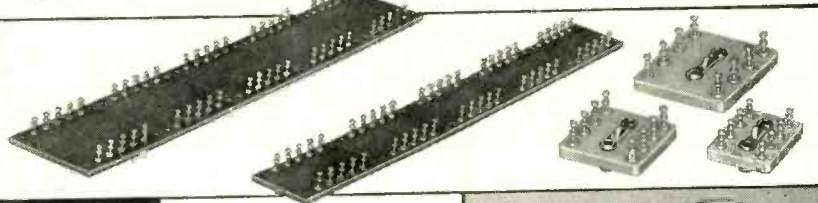

## CTC QUALITY PERMA-TORQ COIL FORMS

Constant-tensioning devices for tuning cores of standard CTC ceramic coil forms. Keeps coils tuned as set despite shock, vibration.

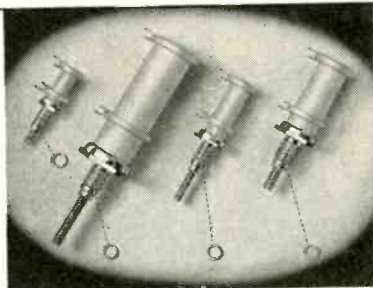

## CTC QUALITY KNOBS AND PANEL HARDWARE

Selected materials, carefully processed and finished. Metal parts polished before plating. Hard-wearing surfaces, lasting lusters.

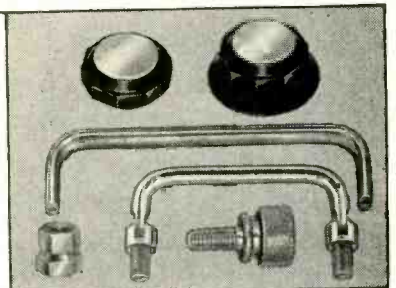

## CTC QUALITY INSULATED TERMINALS

Wide variety of stand-off and feed-through models in Teflon and ceramic. Extremely resistant to shock, vibration, moisture and temperature. Solder terminals hold even after prolonged soldering operations.



## CTC QUALITY PRINTED CIRCUIT COIL FORMS

Phenolic and ceramic types. Can be soldered after mounting. Available as forms alone or wound as specified. Two- to six-terminal models.

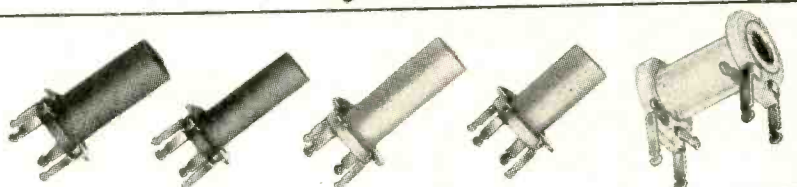



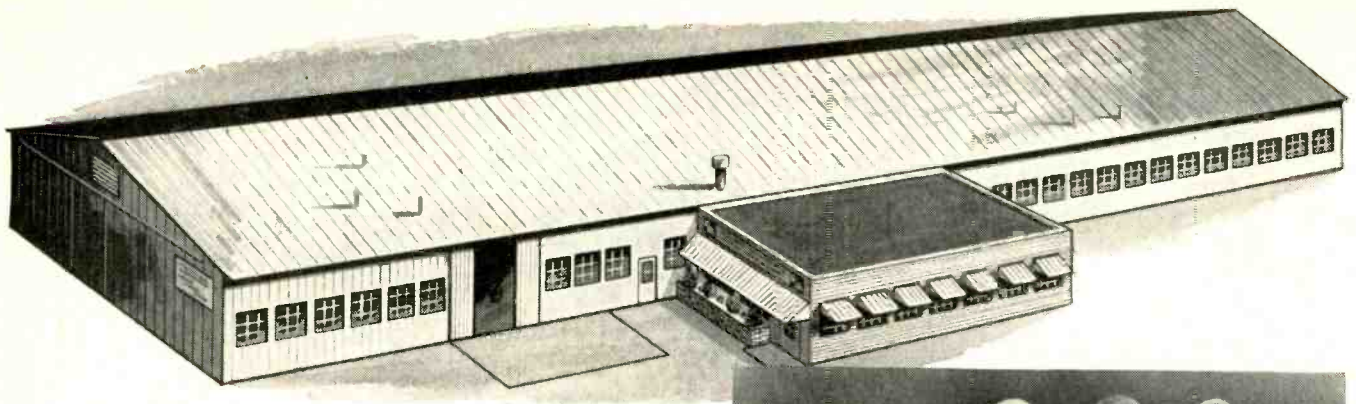

## Raybestos-Manhattan acquires California plant to provide West Coast users with R/M *Teflon*\* products

Raybestos-Manhattan has purchased the Graef Engineering Co., in Paramount, Calif., to serve Western and Southwestern manufacturers as a nearby source of R/M "Teflon," "Kel-F," Nylon and Raylon (a mechanical grade of "Teflon") products. Key personnel will be retained. The plant is fully equipped to extrude, mold and machine "Teflon," "Kel-F" and Nylon products and to spray-coat metal parts with "Teflon" and "Kel-F." It will also stock "Teflon" sheets, tubes, rods and tapes in standard, certified and stress-relieved grades; bondable sheets and tape, gaskets, mechanical packings, expansion joints, and flexible couplings.

Raybestos-Manhattan, a pioneer in fabricating these materials, is one of the largest producers of "Teflon" products for aircraft, electronic, electrical, chemical and various other industrial applications. Call on R/M's experience and skill to help you solve problems involving high temperatures and corrosive fluids and gases.

\*A Du Pont trademark

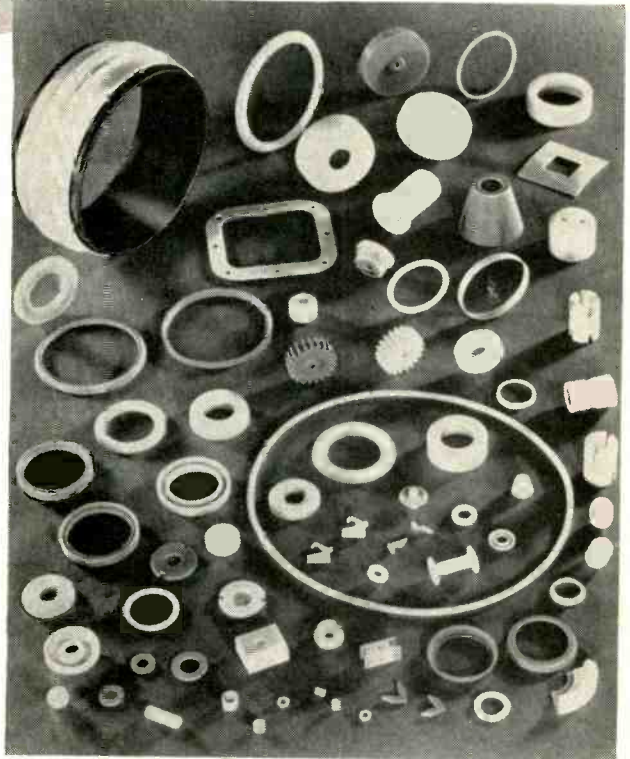

Typical R/M "Teflon" products manufactured at Raybestos-Manhattan's newly acquired plant at 15010 South Downey Ave., Paramount, Calif.

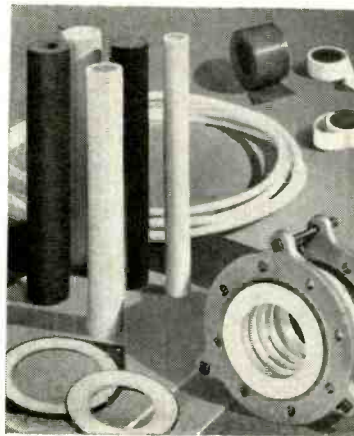

**OTHER R/M "TEFLON" PRODUCTS:** rods, sheets, tubes and tape; centerless ground rods held to very close tolerances; stress-relieved molded rods and tubes; gaskets; expansion joints and flexible couplings; bondable "Teflon"; braided metal- and rubber-covered flexible hose; and Raylon (R/M trade name for mechanical grade "Teflon" which has many of the characteristics of virgin "Teflon"). Write for complete data.

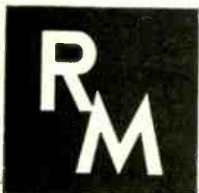

# RAYBESTOS-MANHATTAN, INC.

## PLASTIC PRODUCTS DIVISION, MANHEIM, PA.

FACTORIES: Manheim, Pa.; Bridgeport, Conn.; Paramount, Calif.; No. Charleston, S.C.; Passaic, N.J.; Neenah, Wis.; Crawfordsville, Ind.; Peterborough, Ontario, Canada

RAYBESTOS-MANHATTAN, INC., Engineered Plastics • Asbestos Textiles • Mechanical Packings • Industrial Rubber • Sintered Metal Products • Rubber Covered Equipment  
Abrasive and Diamond Wheels • Brake Linings • Brake Blocks • Clutch Facings • Laundry Pads and Covers • Industrial Adhesives • Bowling Balls



**RHODIUM  
PLATING...  
AN ECONOMICAL,  
HARD, WHITE,  
CORROSION-  
RESISTANT  
SURFACE!**

The characteristics of Rhodium make it extremely well-suited for many electrical and electronic applications. It increases efficiency when a low-resistance, long wearing, oxide-free contact is required. It assures low noise level for moving contacts, no oxide rectification, low and stable contact resistance. Wear on slip rings and commutators is greatly reduced. Resistance to marine and practically all industrial atmospheres is so effective that it is widely used on safety alarm contacts, where positive contact must be assured after periods of long inactivity.

The corrosion-resistant properties of Rhodium Plating make it particularly applicable for printed circuits (long wear and low noise) and ultra-high frequencies (eliminating partial rectification and unwanted signals).

Rhodium plated reflectors are recognized as the finest made. Rhodium plating is unsurpassed when used with the open arc.

Write for complete catalog material and details.



FINE WIRE of ductile and non-ductile material meets the expanding requirements of industry with highest quality.

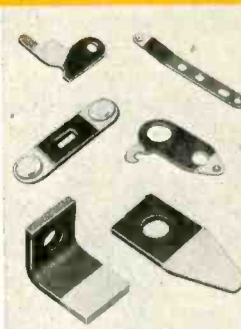

PRECIOUS METAL CONTACTS resist chemical attack and effects of the electrical arc to provide long life, unvarying performance.



SUPER-SENSITIVE DEDXD<sup>TM</sup> INDICATOR measures the faintest traces of oxygen or hydrogen present as impurities in other gases.

**BAKER** PRECIOUS METALS

**BAKER & CO., INC.**

113 ASTOR STREET, NEWARK 2, NEW JERSEY  
NEW YORK • SAN FRANCISCO • LOS ANGELES • CHICAGO

ENGELHARD INDUSTRIES

RESEARCH MAINTAINS BAKER'S LEADERSHIP IN PRECIOUS METALS

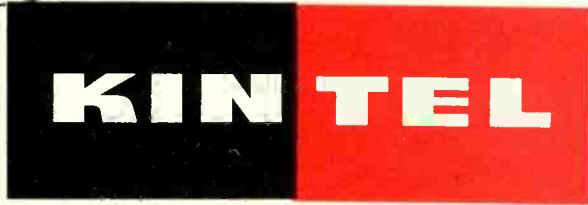
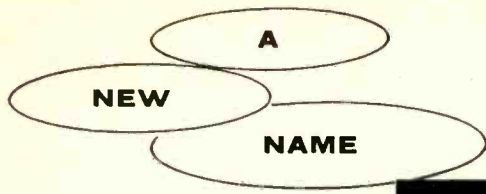

for **KAY LAB** products

The same company, the same engineering and manufacturing facilities, the same world-wide staff of field engineers, but a new name more descriptive of the Company and its products.

LOOK FOR **KIN TEL** ON:



UNIVERSAL DC MICROVOLTMETERS

INDUSTRIAL TELEVISION EQUIPMENT

MICROVOLT LEVEL BROADBAND DC AMPLIFIERS

BROADCAST TELEVISION EQUIPMENT

ABSOLUTE DC POWER SUPPLIES AND METER CALIBRATORS

On these and many other electronic products the name **KIN TEL** means outstanding instruments and television equipment.

**WESCON...BOOTHS 1603-1604**



*Representatives in all major cities*

*Write, wire, phone today for demonstration*

ELECTRONICS FOR COMMUNICATION • MEASUREMENT • CONTROL

5725 KEARNY VILLA ROAD • SAN DIEGO 11, CALIFORNIA • BROWNING 7-6700



# THE ONE UNIVERSAL METER

## MICROVOLTS TO KILOVOLT



The KIN TEL Model 203 is a combination DC microvolt-ammeter and amplifier. It provides an exceptionally wide range of measurements. Fifteen voltage ranges cover from 100 microvolts full scale to 1000 volts full scale, with 100 megohms input impedance. Ten current ranges cover from 100 micro-microamperes full scale to 100 milliamperes full scale. As little as 10 microvolts or 10 micro-microamperes may be measured with accuracy. The uncluttered zero-center meter face instantly indicates polarity on a mirrored scale. When used as a DC amplifier, the instrument features exceptionally low drift with high gain, very high input impedance and low output impedance. Gains up to 80 db with less than 10 microvolts drift may be obtained. The Model 203 utilizes KIN TEL'S unique chopper stabilized circuit to provide high sensitivity with previously unobtainable drift-free stability and high input impedance.

**APPLICATIONS:** Electronic, medical, geophysical, chemical, metallurgical research and development... transistor production and circuit design... thermocouple calibration... null detector... recorder driver amplifier... and as a general purpose laboratory instrument wherever dc voltage and currents are measured or amplified.

### SPECIFICATIONS

Voltage Range (full scale).....	100 $\mu$ v to 1000v	Accuracy on All Ranges.....	$\pm$ 3% of full scale
Current Range (full scale).....	100 $\mu$ ma to 100 ma	Maximum Gain as Amplifier.....	80 db $\pm$ 1.5%
Input Impedance.....	10 megohms below 10 mv, 30 megohms at 30mv, 100 megohms above 30mv	Output Rating.....	1v across 1000 $\Omega$
Impedance Accuracy.....	$\pm$ 1.5%	Output Impedance.....	less than 5 $\Omega$
		Drift (after 15 min. warmup).....	10 $\mu$ v equivalent input
		Price.....	\$550.00

Rack Mounting available as Model 203R

**WESCON...BOOTHS 1603-1604**



**STABILITY**  *Locked in!*  
WITH CHOPPER AMPLIFIERS

5725 KEARNY VILLA ROAD • SAN DIEGO 11, CALIFORNIA • BROWNING 7-6700



**THE TRICK IS TO CONTROL THIS**

**"E" DIMENSION WITHIN .0005"**

Dial indicator gage measures the critical "E" dimension.

## Precision disc cathodes simplify assembly of TV picture tubes

Because Superior Tube guarantees such close tolerance in disc cathode "E" dimension, makers of TV picture tubes can save the time and cost of compensating for variations.

Cathodes can be used universally in different tubes, and are interchangeable with each other during electron gun assembly. This means both manufacturing efficiency and quality control can be significantly improved.

In addition, Superior Tube precision disc cathodes offer these four important advantages:

1. **Separate cap alloy.** Permits use of best alloys for both cap and shank in varying applications.
2. **Slight flare of shank opening.** Easier insertion of heater. Less abrasion of heater coating during normal expansion and contraction.
3. **Shadow groove in ceramic.** Inhibits electrical leakage between cathode and No. 1 grid.
4. **Chemically clean shank interior.** Minimizes heater-cathode leakage.

Superior Tube disc cathodes are available in three sizes: standard, narrow neck making possible shorter tubes, and miniature for 3-gun color TV picture tubes. Write for complete information to Superior Tube Co., 2500 Germantown Ave., Norristown, Pa.

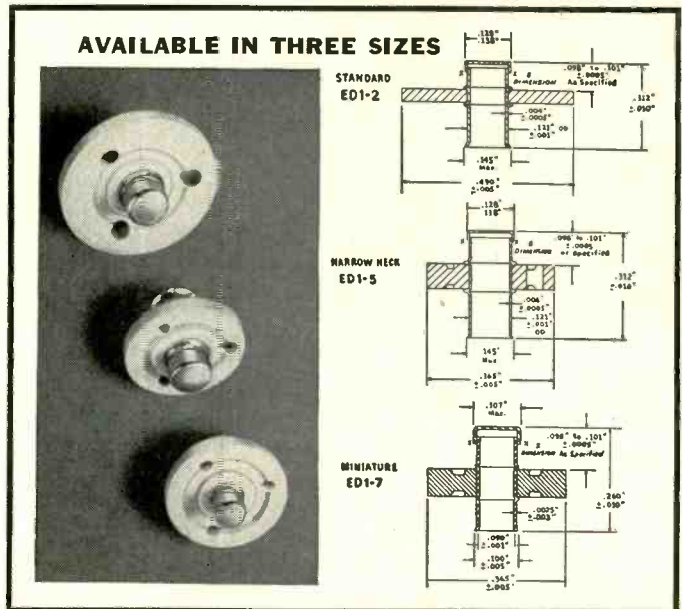

**HOW SUPERIOR DOES IT**—GENERAL CERAMICS CORPORATION, Keasbey, N.J., working for many years with Superior Tube's engineers, has developed mass-production methods resulting in the supply of millions of close-tolerance insulators which have greatly assisted in achieving this uniform "E" dimension. These insulators are produced under rigid quality controls. The cathode shank is double-beaded to the ceramic to insure tight fit. The cap is electrically spot-welded to the shank while held in a precision jig.

# Superior Tube

The big name in small tubing  
NORRISTOWN, PA.

Johnson & Hoffman Mfg. Corp., Mineola, N.Y.—an affiliated company making precision metal stampings and deep-drawn parts such as those used in the electron guns that go with this new cathode.



# Got Your Neck Out On A Cable Problem?

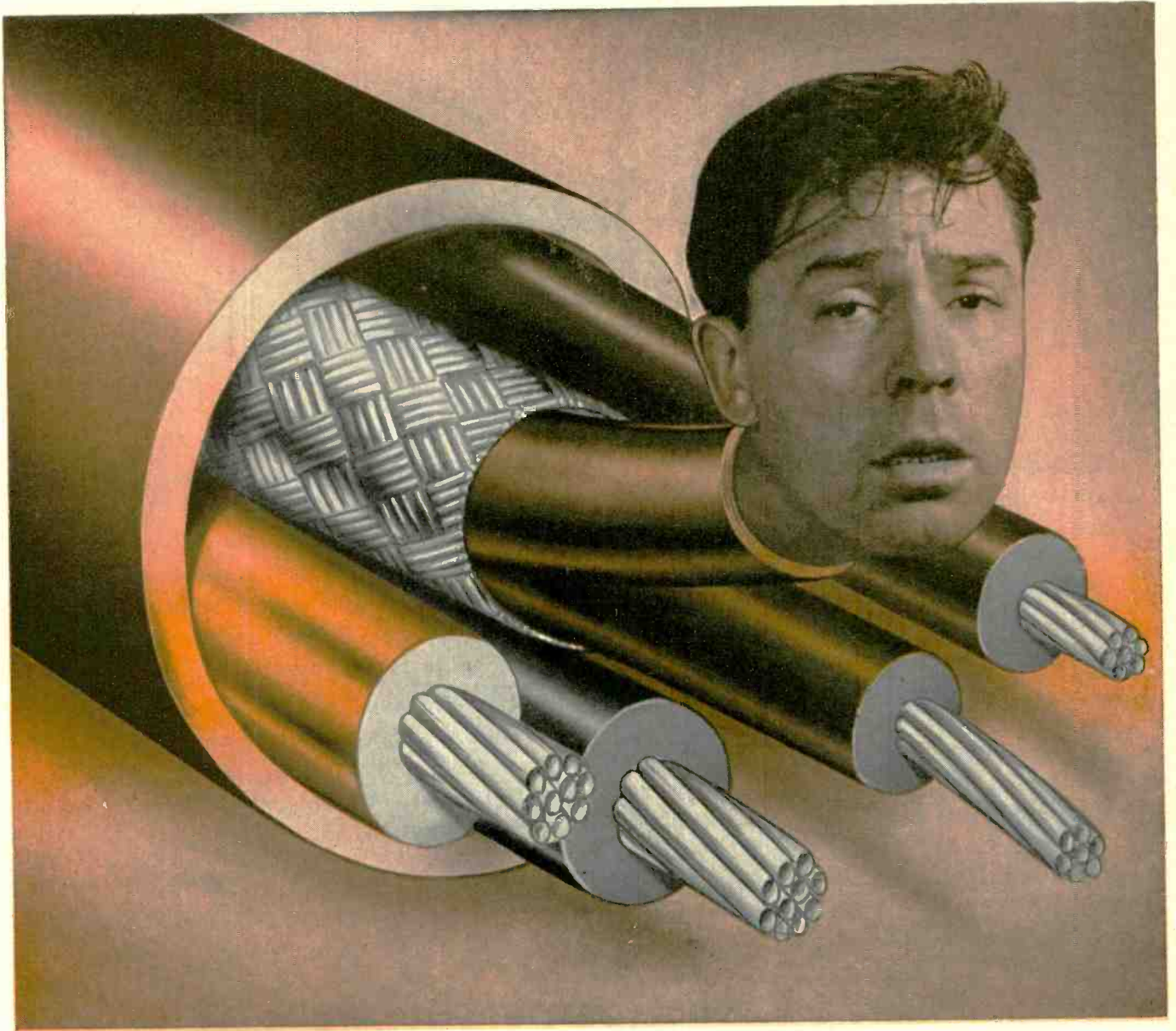

## PHALO Will Haul It In For You!

Here is a pretty painful spot . . . and many necks are lost this way!  
 If your neck is out where the wrong cable decision could materially damage it . . . make the move that will put your adam's apple in back of your collar again . . . the move to PHALO!  
 Be among the necks that stay unstretched

when the problem is custom cables . . . or wires . . . or cord sets.

*This catalog will tell you a lot — ask for it!*



# PHALO

**PLASTICS CORPORATION**  
 Corner of Commercial Street  
 WORCESTER, MASSACHUSETTS

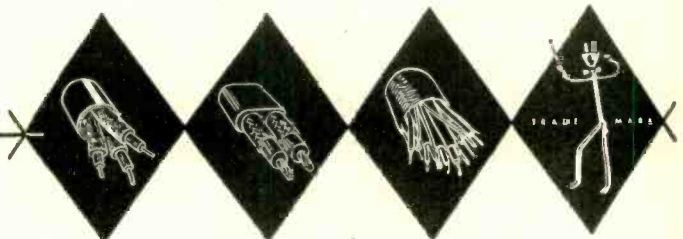

# Is Industry Creating A New Breed of "Bonus Babies"?

THE STARTING SALARIES offered to this year's June graduates give the impression that industry is creating a new breed of "bonus babies." This is the term baseball fans apply to sturdy youngsters whose talent for hitting and throwing gets them payments of up to \$100,000 and other benefits for signing a contract.

For several years industry's demand for young college graduates, especially in science and engineering, has outrun the number receiving degrees. Competition for these young people has steadily pushed up the starting salaries and has induced many companies to indulge in lavish recruiting programs. This year engineering graduates are being offered well over \$400 a month, and even liberal arts graduates find numerous offers at \$400 or more. Only ten years ago the salaries offered senior engineering students averaged less than \$250 a month.

But any employer who assumes that high starting salaries alone will assure him the number of June graduates he wants is likely to be disappointed. A recent study by the McGraw-Hill Classified Advertising Division shows that most young engineers and scientists going into industry are more interested in their opportunities and in a company's future than they are in the size of their first paycheck.

## Money Isn't Everything

In the McGraw-Hill survey, 2,596 recently-hired engineers and scientists employed in 57

companies listed the factors they had considered before accepting a position. The replies of the younger engineers and scientists—those with less than five years' experience—have great significance for employers who want to make any impression in the highly competitive market for college graduates.

- Potential growth of the company was listed by more young engineers and scientists than any of the 42 other items on the list as a factor that influenced greatly their decision in accepting a position.
- Challenging opportunity was second.
- The company's prestige and reputation ranked third.

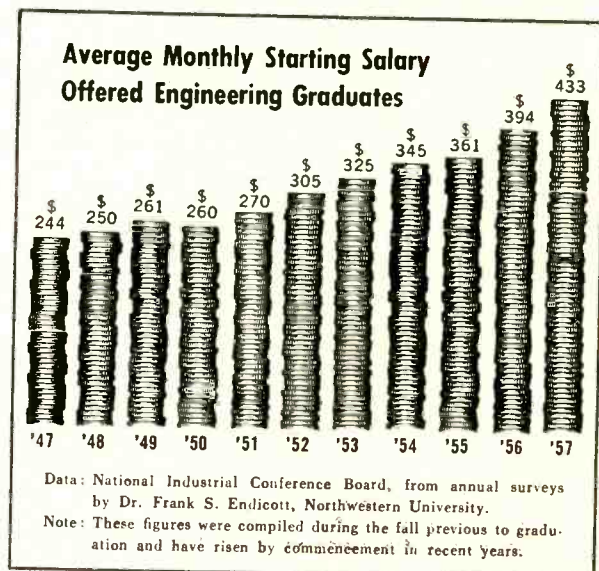



- Progressive research and development program was fourth.
- Starting salary ranked only seventh.

### Job and Future Most Important

As a group, the factors relating to the nature of the job, its future and the company's future had by far the greatest influence in attracting young engineers and scientists to their present positions. These include three of the top four attractions—potential growth of the company, a challenging opportunity and a progressive research and development program. Other factors in this group are the company's facilities, quick advancement, self-direction or little supervision, chance to work in a certain field, small size of company and rewards for individual accomplishment.

The second most important group of attractions had to do with prestige. These include the company's prestige and reputation, executive or professional standing and association with leading men in the field. Third in importance were financial considerations—starting salary, regular salary increases, financing of relocation, paid vacations and holidays.

A less important group of factors influencing young scientists and engineers were essentially social. Geographic location and educational facilities in vicinity ranked fairly high. But recreational facilities, suburban or country living, pleasant housing and cultural considerations had little appeal.

Ranking lowest, by a good margin, were factors having to do with security—permanent position; health, life and surgical insurance; retirement or pension plan; and sick leave.

It is interesting to note that some of the factors which influenced the smallest percentage of young engineers and scientists were country club memberships, use of company car, at-cost or low-cost eating place, travel opportunities abroad and being able to buy the company's products at a discount.

### A Lesson For Employers

The lesson of this survey to employers who

### What Factors Influence the Job Selections of Young Engineers and Scientists?

Factors Influencing Decision Greatly	Percent Listing Factor
Potential growth of company.....	55%
Challenging opportunity.....	53
Company's prestige, reputation.....	44
Progressive research and development program..	41
Geographic location.....	37
Permanent position.....	35
Starting salary.....	34
Educational facilities in vicinity.....	33
Regular salary increases.....	31
Chance to work on specific project, or in certain field.....	27
Company's facilities (laboratories, technical libraries, etc.).....	25
Tuition for graduate study.....	25

Based on replies by recently-hired engineers and scientists with less than five years' experience to questionnaire distributed by McGraw-Hill Classified Advertising Division.

hope to recruit more young engineers and scientists is clear. High salaries and other financial appeals are important. But, at a time when high starting salaries are offered in abundance, our young graduates are interested even more in being with companies that will grow and in jobs that will permit them to grow. They are interested in jobs that offer opportunities for advancement, financially and professionally.

\* \* \*

Were the young scientists and engineers who participated in the survey trying to impress somebody with their motives? If so, it could only have been to impress themselves, for all were asked to return their questionnaires unsigned.

*This message is one of a series prepared by the McGraw-Hill Department of Economics to help increase public knowledge and understanding of important nation-wide developments. Permission is freely extended to newspapers, groups or individuals to quote or reprint all or parts of the text.*

*Donald McGraw*  
PRESIDENT

McGraw-Hill Publishing Company, Inc.

# WESTINGHOUSE **MAGAMP**

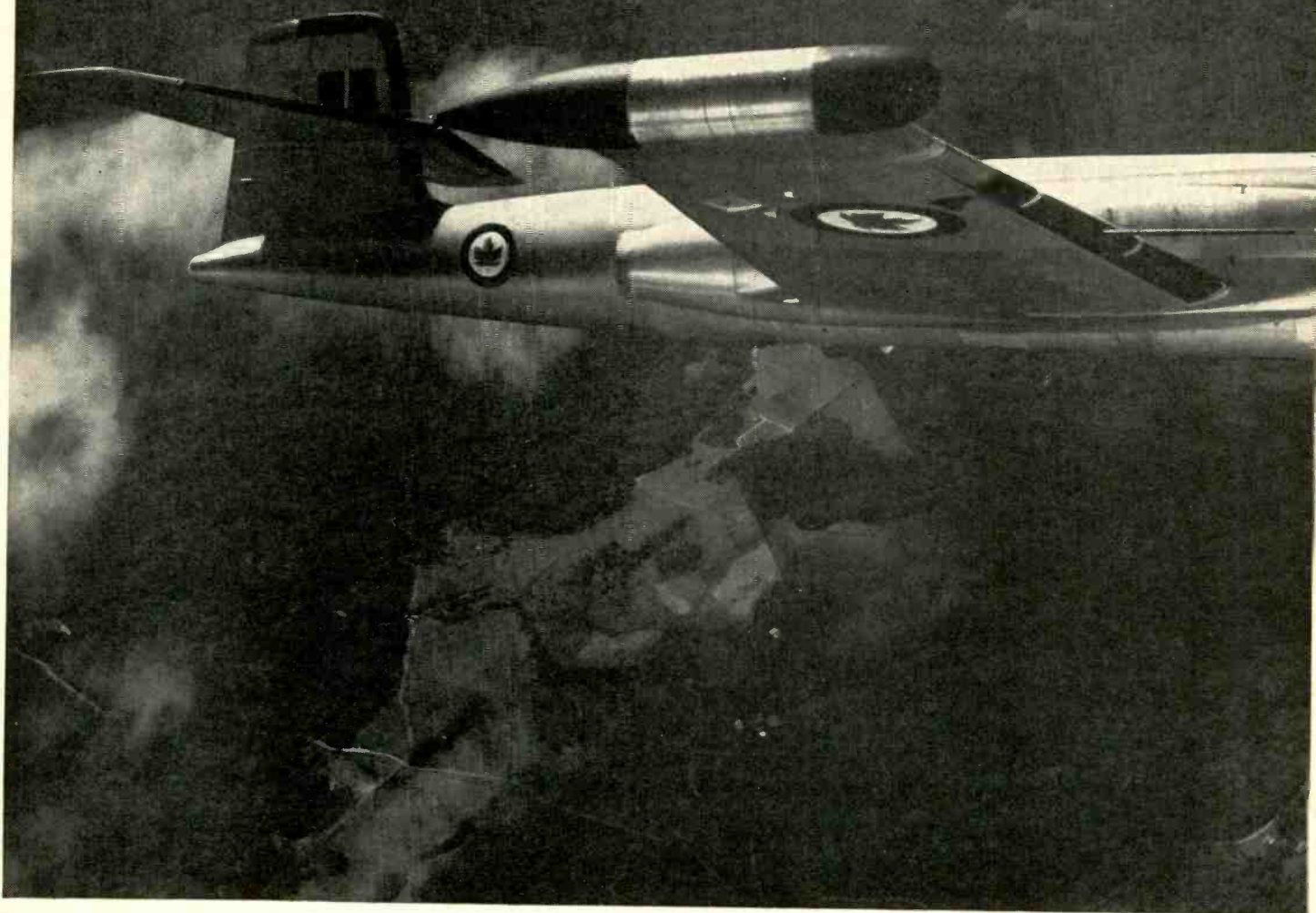

Another Example of CREATIVE MAGAMP ENGINEERING By Westinghouse



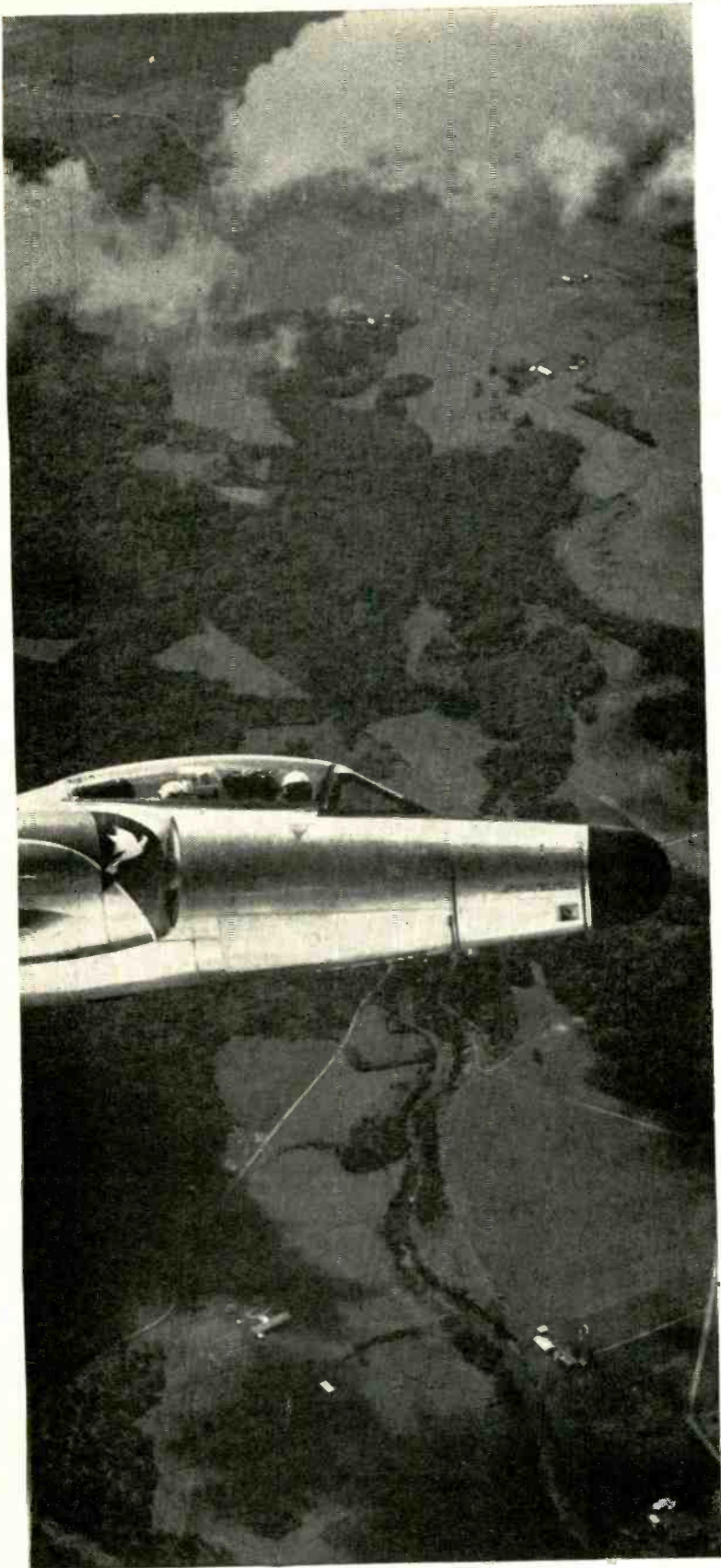

## World's Lightest Magnetic Amplifier Regulator Unit . . . Capable of Voltage Regulation Plus or Minus 1 Volt up to 120°C.

The high altitude missile-carrying CF-100 Mark VI, designed and developed by Avro Aircraft Ltd., of Canada, is undergoing advanced flight testing. Complete dependability and fast response are critical in control and power supply components for these all-weather aircraft. That's why Westinghouse transformer-rectifier unit with MAGAMP\* static control was specified — it assures electrical system reliability over a wide range of temperatures and altitudes on aircraft and guided missiles.

Using a 12-phase amplifier and silicon rectifiers, Westinghouse can obtain an output of 5.6 kw . . . yet the unit occupies less than one cubic foot and weighs only 62 pounds. By designing reactors that will operate at 200°C internal temperatures, Westinghouse engineers are able to provide the only magnetic amplifier voltage regulator on the market that will operate at a sea-level temperature of -55°C to +120°C.

This is an example of Westinghouse creative MAGAMP engineering to solve today's problems and tomorrow's applications. For information or engineering assistance on your specific control problems, call your Westinghouse sales engineer, or write Westinghouse Electric Corporation, P.O. Box 868, 3 Gateway Center, Pittsburgh 30, Pennsylvania.

\*TRADE-MARK

J-22030

### MAGAMP STATIC REGULATOR CHARACTERISTICS

**INPUT**

190 to 210 volts rm-3 phase

**OUTPUT**

28 volts at 200 amperes

**FREQUENCY RANGE**

380 to 420 cps

**RIPPLE**

1.5-volt peak ripple

**TRANSIENT RESPONSE**

0.2-second maximum

**EFFICIENCY**

Minimum of 80% at full load

**PERFORMANCE**

As specified in MIL-E 5272 A

**LIFE**

1,000 hours minimum with no maintenance or adjustments.

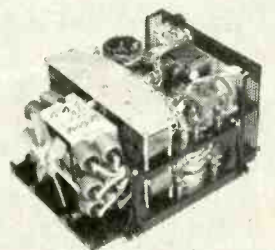

YOU CAN BE SURE...IF IT'S **Westinghouse**





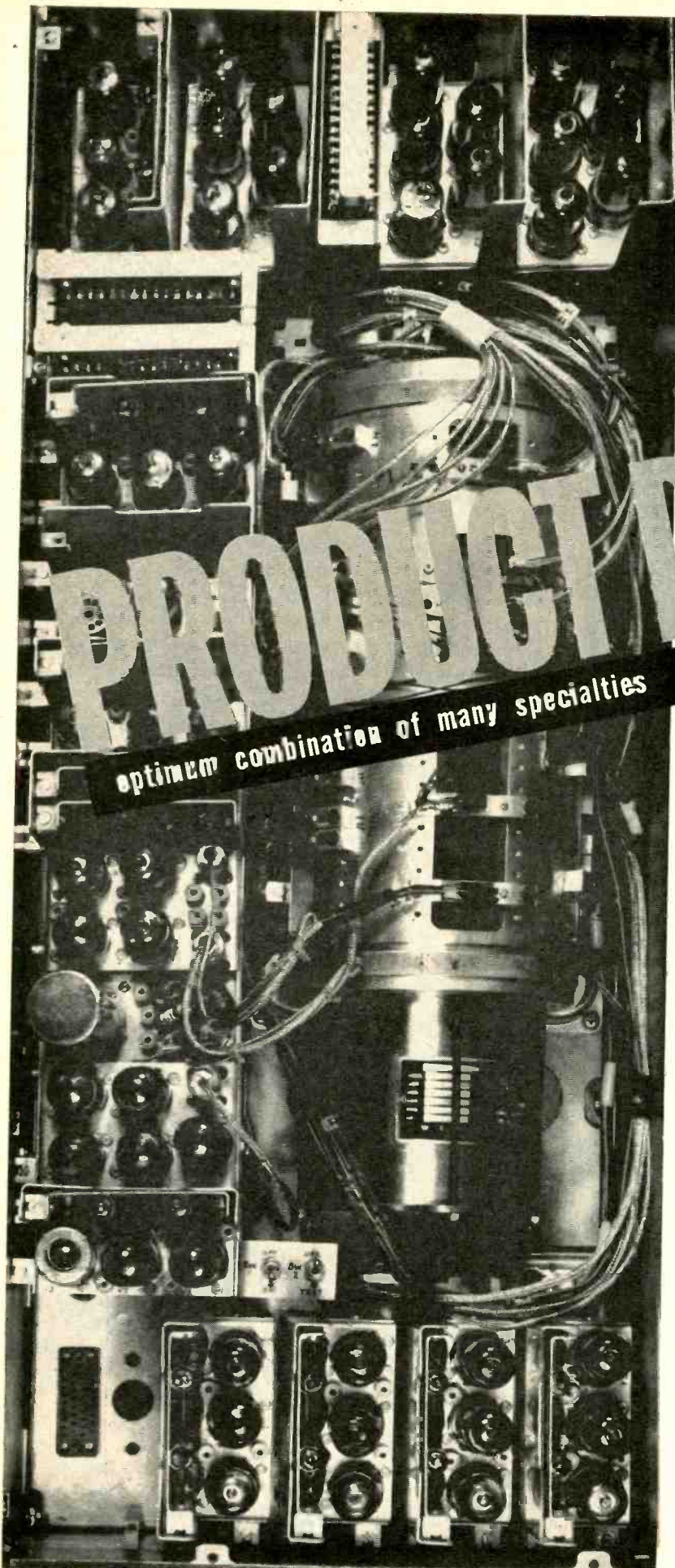

RELIABILITY ANALYSIS,  
MAINTAINABILITY, HEAT TRANSFER,  
COMPONENT APPLICATION,  
MINIATURIZATION,  
ECONOMY

# PRODUCT DESIGN

optimum combination of many specialties

Electronic Product Design at Hughes is the optimum of many and varied specialties. This expert coordination of specialists has resulted in the solution of complex packaging problems, including the airborne Electronic Armament System and the Falcon guided missile.

New projects soon to be underway concern developing practical solutions to the theoretical and actual problems associated with Electronic Product Design.

These Hughes projects have both military and commercial application, assuring you of an unlimited future. Engineering positions to be filled include the following: Reliability, Component Application, Electromechanical Development, Miniaturization and Packaging, Chemical and Metallurgical, Applications and Precision Electronics Test-Supervisor.

Investigate this opportunity to combine challenging work with the ideal living conditions in suburban Los Angeles. Send your resume to the address below.

THE WEST'S LEADER IN ADVANCED ELECTRONICS

## HUGHES

RESEARCH AND  
DEVELOPMENT LABORATORIES

SCIENTIFIC STAFF RELATIONS  
HUGHES AIRCRAFT CO., ROOM 2046-C  
CULVER CITY, CALIFORNIA



DIRECT DISPLAY CATHODE RAY

# STORAGE TUBES BY HUGHES

## TONOTRON\*

Half-tone Storage Tube...for Radar PPI Display or Closed-Circuit TV.

Such distinct advantages as controllable long persistence and ability to cover the entire grey spectrum contribute to the versatility of the Hughes TONOTRON direct display storage tube. Because the TONOTRON electron tube has an over-all length of only 11 3/8" ( $\pm 3/8"$ ), it can be installed in many existing radar indicator housings in both military and commercial aircraft. Brilliance of 1000 foot-lamberts at 10 kv enables the pilot to view radar presentations in full daylight without using a vision-restricting viewing hood. When used in narrow band, slow scan television, the TONOTRON storage tube eliminates need for costly coaxial cables or microwave transmitters and receivers, since pictures can be transmitted over conventional radio channels or telephone lines.



Brilliant half-tone presentation in weather radar.

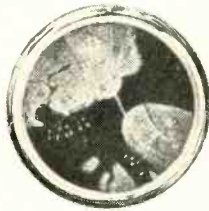

Maximum contrast makes ground radar read "like a map."



Resolution of 80 lines per inch in narrow-band TV.



Action can be frozen for subjective examination.

## MEMOTRON®

Oscillograph Storage Tube

...for Retaining Displays of Electrical Phenomena.

Traces and transients may be visibly retained on the face of the Hughes MEMOTRON direct display storage tube as long as desired—and successive waveforms can be displayed and retained for analysis and comparison without needless photography.

When permanent records are required, photographs may be taken with a single camera exposure setting, since all displays occur at the same brightness regardless of differences in writing speeds.

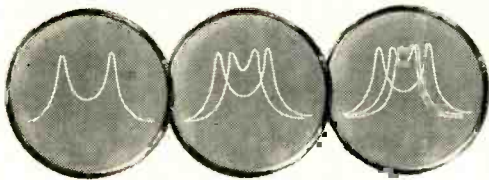

A technique for plotting a family of curves, representing a coupled circuit with varied parameters.

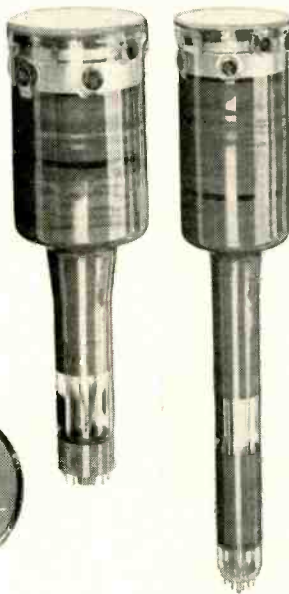

## TYPOTRON®

Character-Writing Storage Tube

...for Use as a Read-Out Device for Computers.

When used in such digital computer applications as programming aid, solution read-out and trouble-shooting, the Hughes TYPOTRON direct display storage tube effectively monitors a problem as it goes through various phases toward a solution.

A choice of 63 characters is available for presentation of data in words, numbers or symbols at speeds of at least 25,000 characters per second. Written information remains visible indefinitely without fading or blooming until intentionally erased.



Presentation of printed data is displayed with 1/8-inch characters.

You are invited to see demonstrations of Hughes direct display storage tubes at Booths 2910-11-12-13, Western Electronics Convention, San Francisco, August 20 through 23. For additional information, write to: HUGHES PRODUCTS • Electron Tubes, International Airport Station, Los Angeles 45, California.

Creating a  
new world  
with  
ELECTRONICS

**HUGHES PRODUCTS**

\*Trademark of Hughes Aircraft Company

© 1957, HUGHES AIRCRAFT COMPANY



# CAPACITORS

SOLDER-COATED LEAD

LEAD CONNECTOR

SOLDER

EXPOSED FOIL

PAPER AND FOIL WITH SOLID IMPREGNANT

COMPRESSION-MOLDED PHENOLIC CASE

COLOR CODE

CUTAWAY VIEW OF PVZ CAPACITOR ENLARGED 13 TIMES

VOLTAGE RATING VS LIFE AT ELEVATED TEMPERATURE FOR 95% RELIABILITY

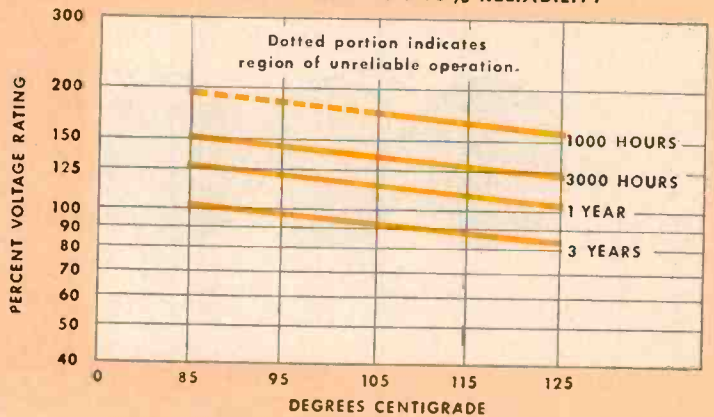

GRAPH ABOVE shows outstanding temperature and voltage characteristics for 95% reliability.



# Solve critical space and temperature problems with subminiature PVZ\* capacitors

Low-cost molded units operate from  $-55\text{ C}$  to  $+125\text{ C}$

Now immediately available for exacting applications in commercial and military electronic equipment, these molded paper capacitors meet performance requirements of Characteristic "E" for MIL-C-91A. General Electric's PVZ capacitors are priced substantially lower than comparable metal-clad tubulars. They are designed to operate for a minimum of one year at  $+125\text{ C}$  with no voltage derating.

Completely solid after molding, PVZ capacitors feature the following advantages:

- small size
- excellent humidity resistance
- high lead-strength

- insulated body—solid impregnant
- high shock and vibration resistance
- color code for easy identification

General Electric PVZ capacitors are available at 100, 200, 300, and 400 volts. Microfarad ratings range from .00047 to .15.

If you need a capacitor with the characteristics described above, ask your General Electric Apparatus Sales Engineer about PVZ tubulars. He can give you expert application information. He can also arrange for immediate delivery of PVZ capacitors from factory stock in most ratings. For descriptive data write for bulletin GEC-1452 to General Electric, Section 447-2, Schenectady 5, N. Y. \*Trademark of the General Electric Co.

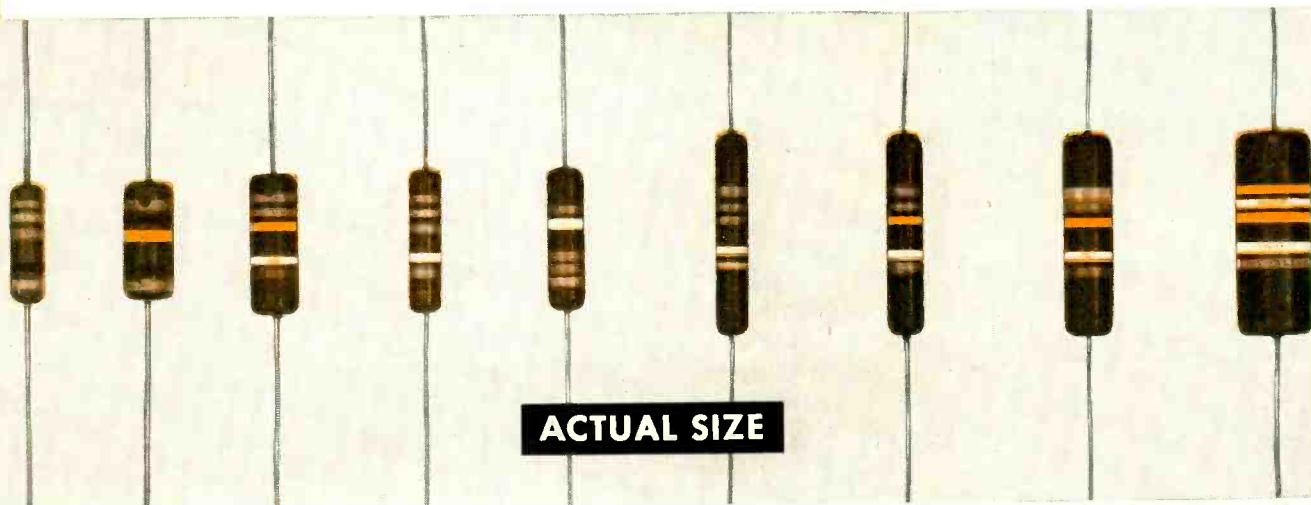

PVZ CAPACITORS range in size from .175" diameter by .625" length to .375" diameter by 1.0625" length. Capacitance ratings

are available with  $\pm 20\%$ ,  $\pm 10\%$ , and  $\pm 5\%$  tolerances. The color code indicates microfarads, volts, and capacitance tolerance.

*Progress Is Our Most Important Product*

GENERAL  ELECTRIC

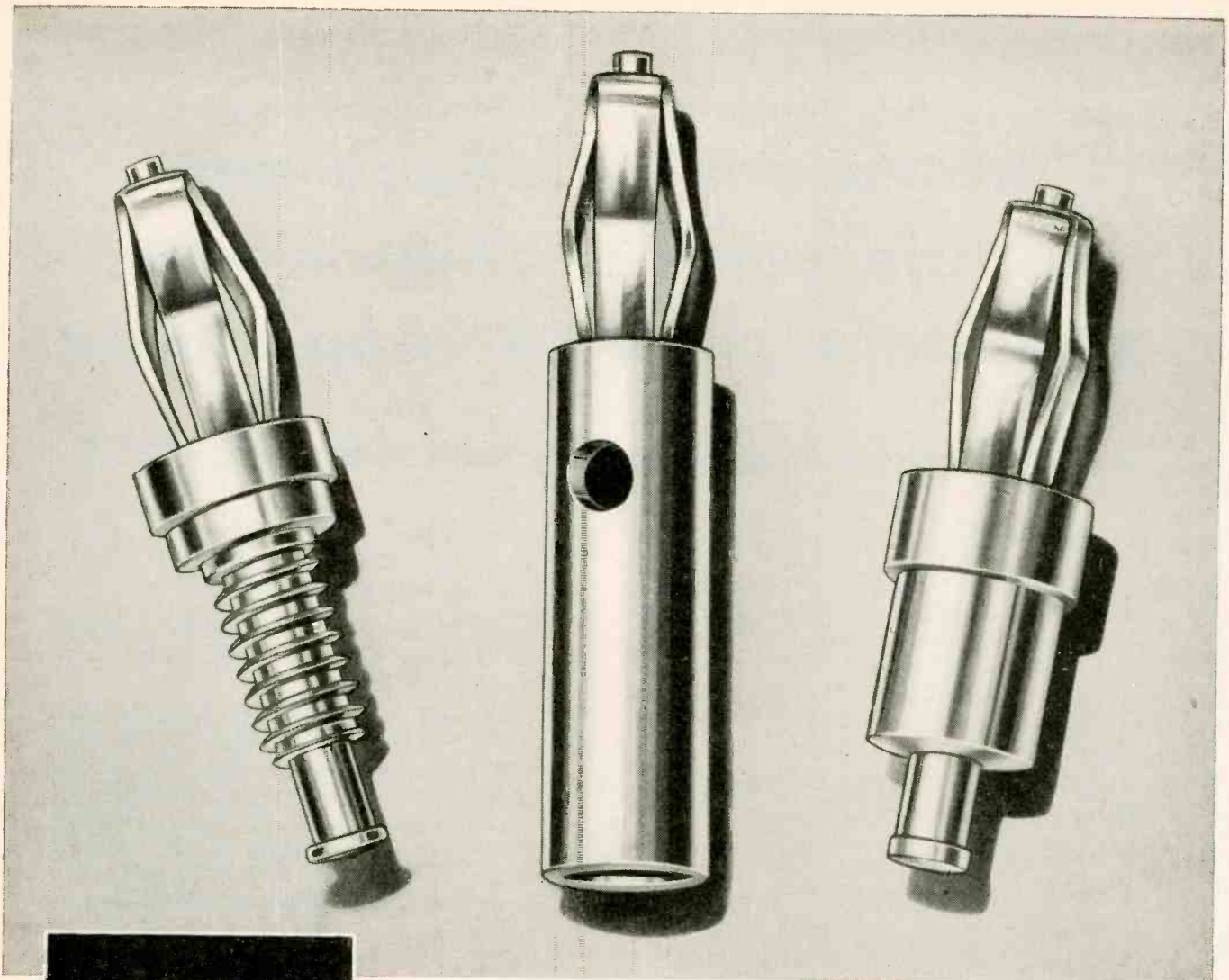

6 times enlargement

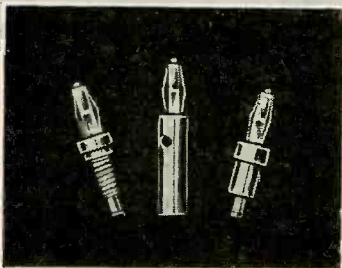

Actual size

# Ucinite Miniature Banana Pins

Heavy resistance to torque is a big feature of Ucinite miniature banana pins. The springs are mechanically riveted over and the large area around the tip of the pin is bonded by solder.

Pins are available in a variety of types, for assembly by staking . . . with nuts and washers . . . with soldered tails . . . with multiple plug-in features. Springs are designed to fit .093 sockets.

Built to withstand rough usage, Ucinite miniature banana pins are available in cadmium, silver or gold plate.

For further information, call your nearest United-Carr representative or write directly to us.



**The**  
**UCINITE CO.**  
*Newtonville 60, Mass.*  
Division of United-Carr Fastener Corp.

*Specialists in*  
**ELECTRICAL ASSEMBLIES,  
RADIO AND AUTOMOTIVE**



# HOW MANY WAYS CAN Special Purpose Fasteners CUT COSTS FOR YOU?

How many of your products employ laborious, old-fashioned fastening methods where simple fasteners could do the job and cut costs, too? How many parts and sub-assemblies can be adapted to include a self-fastening feature? How many future products could be improved by advance planning for fastener efficiency?

United-Carr's engineering staff offers you a wealth of experience in the design of special-purpose fasteners and self-fastening devices. Large-scale manufacturing facilities (including in-plant plastics molding equipment) ensure economical, *volume* production and prompt deliveries. United-Carr field representatives are ready to call on you at *your* request.

## POLYETHYLENE MOUNTING FOOT



No mar, no scratch glide for use on TV receivers, record changers, small appliances, etc. Assembles into round hole in wood or metal cabinets.

## NYLON SNAP-IN NUT



Snaps into square hole stamped out of sheet metal... provides secure anchorage for any sheet metal or self-topping screw... highly effective electrical insulator.

## QUICKEY FASTENER



Eliminates need for welding or swaging studs to sheet metal stampings, facilitates nesting, eliminates damage in transit because Quickey snaps in before final assembly.

## THREAD CUTTING FASTENER



Re-usable, self-locking, vibration-proof fastener cuts clean, deep threads on unthreaded chrome-plated studs. Available for 1/8", 3/16" and 1/4" studs.

## PLUG BUTTONS



Snap into 1/8" to 3" dia. holes. Can be embossed with ornamental or functional designs... various finishes, shapes and sizes.

## FISHTAIL RATCHET PLATE



Holds on smooth, die-cast metal or plastic studs to anchor name plates, trade marks etc. on appliances, automobiles, electronic apparatus, etc.

## TRIMOUNT STUDS



Hold two or more thicknesses of material together. Easily installed by hand. Insure vibration proof attachment. Permanent or removable. Many shapes and sizes.

## V-LOCK TEENUT



Re-usable, self-locking, one-piece, all-metal nut has high tensile strength, is unaffected by heat or oils. In various shapes, sizes and metals.

## SOL-A-NUT



Self-locking, rustless, heat resistant. Sturdy, one-piece stainless steel construction prevents corrosion if nicked or scratched.

## DURABLE DOT FASTENER

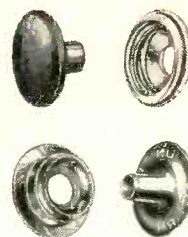

Snap fastener for cloth, leather, plastics and other materials. Positive closure, instant release. Black, nickel or brass finish.

# CARR FASTENER COMPANY

Division of United-Carr Fastener Corp., Cambridge 42, Massachusetts

MAKERS OF  FASTENERS

# Phelps Dodge modern fits new



*First for Lasting Quality—from Mine to Market!*



# enamel wire

## exacting coil designs!

*New processes and controls  
assure uniform quality:*

- 1** Uniform over-all size — for uniform windings.
- 2** Uniform softness with high tensile strength for tighter windings, reduced breakage.
- 3** Uniform spooling, larger packages for lower-cost windings.
- 4** Uniform property balance for good flexibility, solvent resistance and dielectric strength.

*Any time magnet wire is your problem,  
consult Phelps Dodge for the quickest, easiest answer!*

Visit Our Booth No. 1111 at WESCON Show, August 20-23, 1957



**PHELPS DODGE COPPER PRODUCTS**  
**CORPORATION**

**INCA MANUFACTURING DIVISION**  
FORT WAYNE, INDIANA

# Model 630-NA

Volt-Ohm-Milliammeter \$74.50

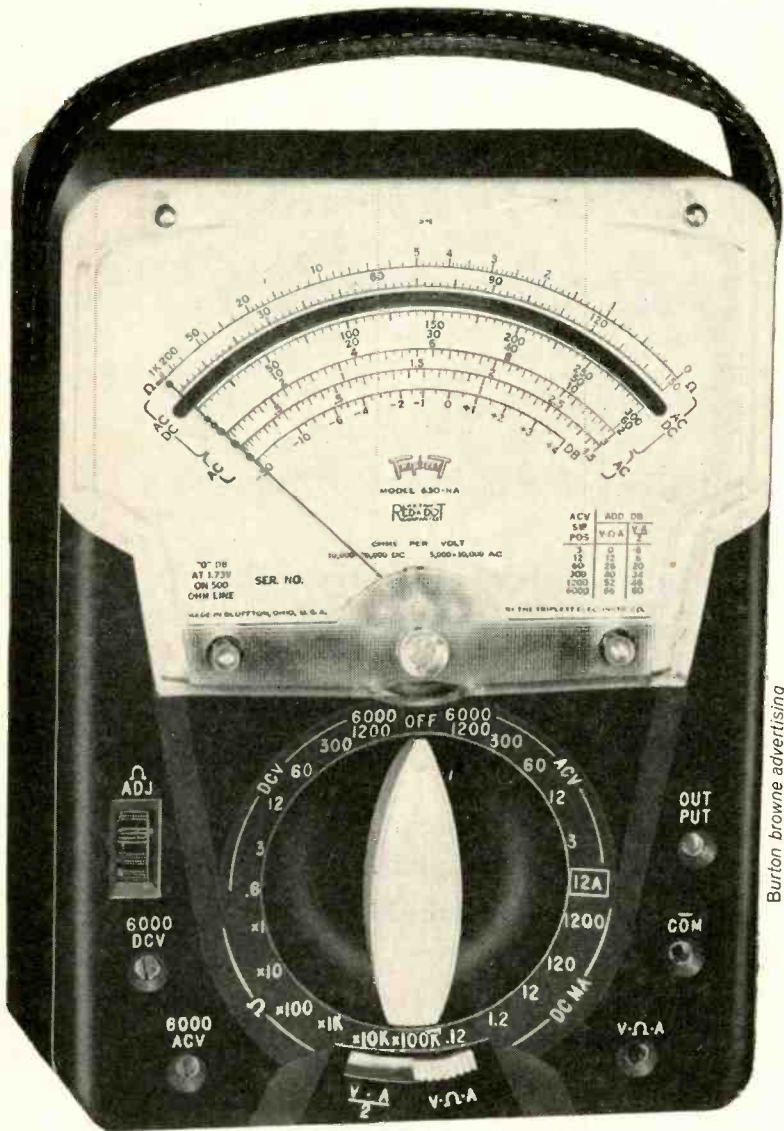

Burton Browne Advertising



*All this in one V-O-M  
70 Ranges... nearly double those of  
conventional testers*

*Meter protection against overloads*

*Frequency compensated... for accurate  
readings through 20,000 cps audio.*

*Highest accuracy—1½% DC to 1200  
volts, 3% AC to 1200 volts: mirror scale and  
knife-edge pointer to eliminate parallax.*

*AC-DC on same scale.*

*Reads 0.1 ohms through 100 megohms.*

Incorporating the famous Triplet SINGLE KNOB CONTROL, Model 630-NA comes complete with snap-out batteries (standard D cell for longer life), test leads, alligator clips, non-skid rubber feet and thorough instruction book. OTHER LEADING TRIPLET FEATURES: Low resistance contacts through banana plugs—completely insulated heavy molded case—clear plastic front with longer easily readable scales—standard sensitivities as used in electronics field.

# TRIPLET

TRIPLET ELECTRICAL INSTRUMENT COMPANY • Bluffton, Ohio



**631**  
Combination  
V-O-M—VTMM



**630**  
The Popular  
All-Purpose  
V-O-M



**630-A**  
A Good Lab and  
Production Line  
V-O-M



**310**  
The Smallest  
Complete V-O-M  
With Switch



**630-T**  
For Telephone  
Service



**666-MH**  
Medium Size  
For  
Field Testing



**625-NA**  
The First V-O-M  
With 10,000  
Ohms/Volt AC



**666-R**  
Medium Size  
With  
630 Features

## THE MIGHTY NINE V-O-M LINE



# HIGH SPEED RELAYS

by Iron Fireman

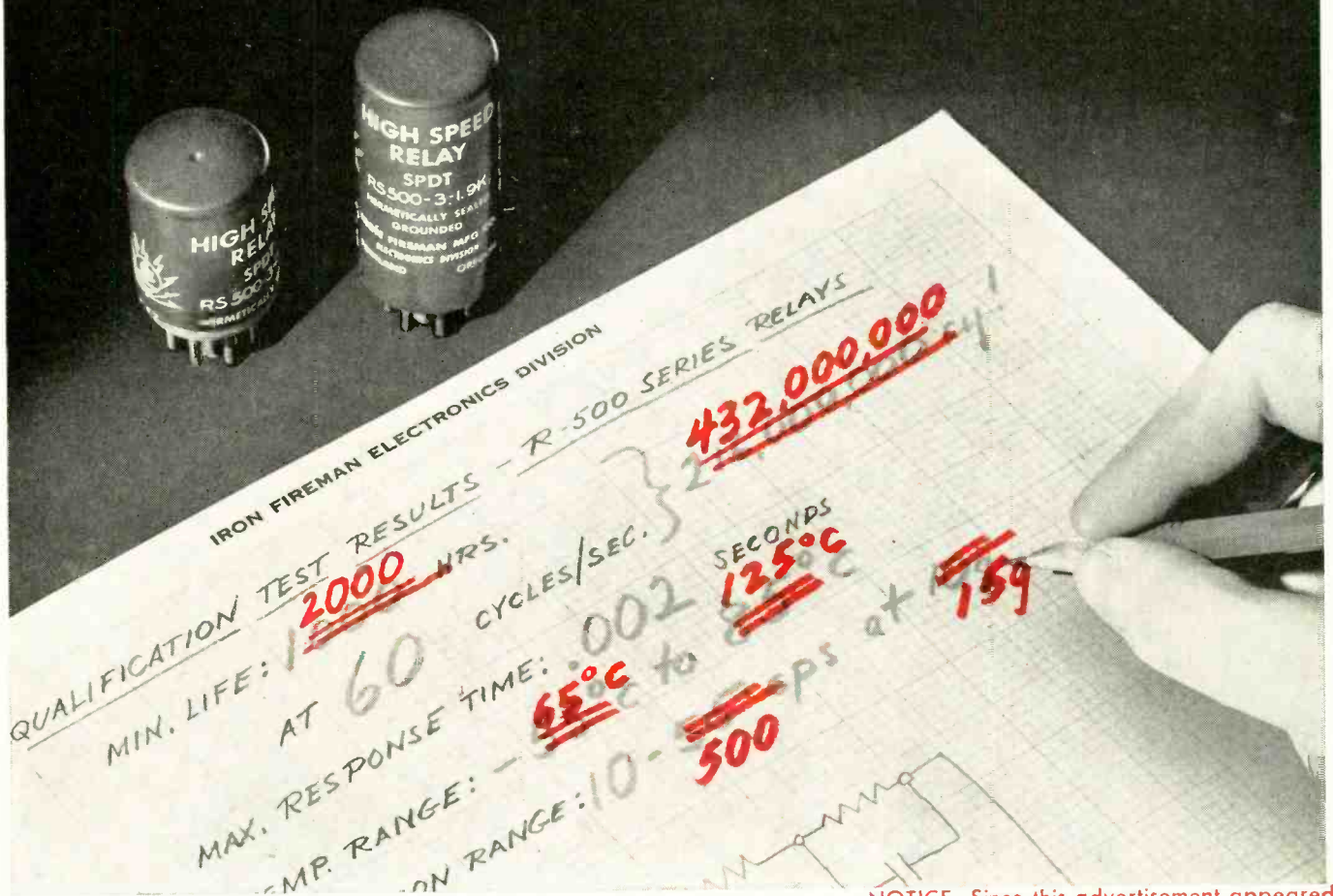

NOTICE: Since this advertisement appeared last month, continued testing to more rigid requirements have given the results shown in red.

## TWO SEALED CELLS

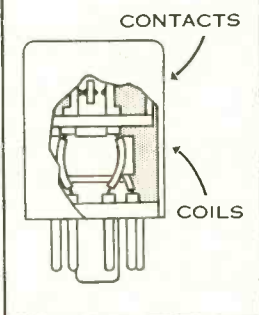

## A brand new design

This Iron Fireman high speed relay is a completely new design. It features improved performance and reliability.

The contacts are enclosed in a separate hermetically-sealed compartment within the outer case—which is also hermetically sealed. This double sealing in inert gas eliminates any possibility of contact contamination.

Not even volatile emanations from warm coils or wires can affect the contacts.

This is but one of the factors contributing to exceptional service life. Complete performance data available on request. Write to the address below for information on high speed or sensitive relays.



**IRON FIREMAN** *Electronics* **DIVISION**

2838 S. E. NINTH AVENUE, PORTLAND 2, OREGON

# TAKE A PAGE FROM THIS ENGINEER'S NOTEBOOK—

Project 604 For Engine Test Section

New job assigned 14 May  
 Design direct-reading tachometer 0-12,000 rpm  
 -basic problem: to measure Frequency  
 -proposed solution: generate constant area pulse one for each cycle, feed these pulses to a meter

Block Diagram

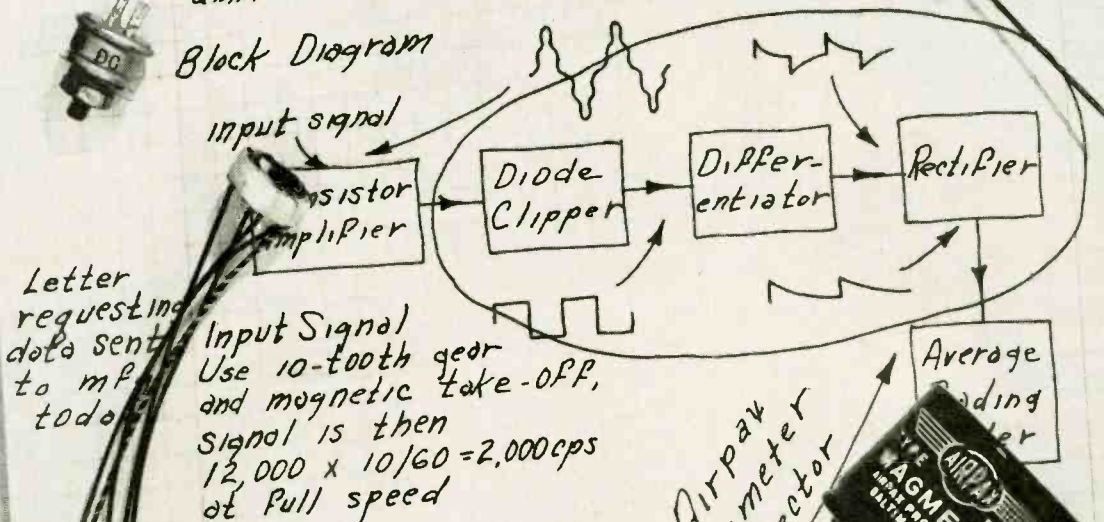

Letter requesting data sent to mfg today

Input Signal Use 10-tooth gear and magnetic take-off, signal is then  $12,000 \times 10/60 = 2,000 \text{ cps}$  at full speed

Transistor Amplifier Use Airpax Magmeter detector

Following is based on data supplied by Airpax (1st attached)

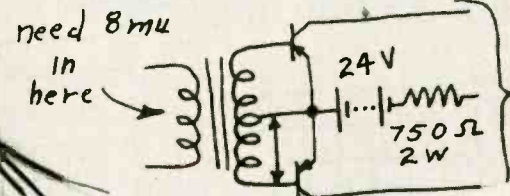

design xFormer to give 4m

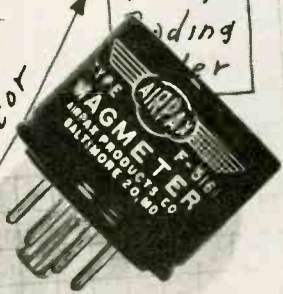

for tachometer project



CENTRAL ENGINEERING DIVISION, FT. LAUDERDALE, FLA.

- CHOPPERS
- VIBRATORS
- CIRCUIT BREAKERS
- FERRAC MAGNETIC AMPLIFIERS
- MAGMETER FREQUENCY DETECTORS
- POWER, AUDIO, AND PULSE TRANSFORMERS



# ALSIMAG<sup>®</sup>

## DATA FOR DESIGNERS

### Abrasion Resistant

Sand Blast Nozzles. Spray Nozzles. Hard, homogeneous, long-lived. Suited to the most exacting uses.

### Precision Tolerances

Minute, yet strong tubing of AISiMag Alumina. Parts in inset magnified three times (smaller one .013" OD); others approximate actual size.

## NEW!

*AISiMag Alumina Ceramics  
open new fields for designers . . .  
permit designing to higher temperatures,  
higher frequencies, greater strengths.*

Designers are generally familiar with the plus values of AISiMag technical ceramics for standard industry applications. However, recent developments—particularly in new, high-strength, high-temperature AISiMag Aluminas—have greatly enlarged their range of usefulness.

Do you need a material with such versatile characteristics as shown on this page? AISiMag technical ceramics have helped many designers solve problems . . . may help solve yours. Send blueprint with complete operating details for our recommendations.

VISIT OUR BOOTHS NOS. 921-922 AT 1957 WESCON

## AMERICAN LAVA

**CORPORATION**  
CHATTANOOGA 5, TENN.  
56TH YEAR OF CERAMIC LEADERSHIP



A subsidiary of  
Minnesota Mining and  
Manufacturing Company

For service, contact Minnesota Mining & Manufacturing Co. Offices in these cities (see your local telephone directory): Atlanta, Ga. • Boston: Newton Center, Mass. • Buffalo, N. Y. • Chicago, Ill. • Cincinnati, O. • Cleveland, O. • Dallas, Texas • Detroit, Mich. • High Point, N. C. • Los Angeles, Calif. • New York: Ridgefield, N. J. • Philadelphia, Pa. • Pittsburgh, Pa. • St. Louis, Mo. • St. Paul, Minn. • So. San Francisco, Calif. • Seattle, Wash. • Canada: Minnesota Mining & Manufacturing of Canada, Ltd., P. O. Box 757, London, Ont. All other export: Minnesota Mining & Manufacturing Co., International Division, 99 Park Ave., New York, N. Y.

### Thin . . . Strong

Electron Tube Spacers as thin as .009" have remarkable strength. Similar parts might solve other application problems where superior insulation is needed.

### Durable

Rollers for flattening inductance wire—a new application for AISiMag.

### Precision Finishes

Smooth, easily coated AISiMag Cores for Ink, Metal Film and Carbon Deposited Resistors.

### Heat Resistant

Support Rings for Heat Treating Fixtures. Welding Jigs. Hold-down Jigs for heat applications.

### Acid Resistant

Rotary Seals and Plungers. Extraordinary wearing qualities. Surface finishes to most exacting specifications.



an  
engineer  
who has  
all the answers

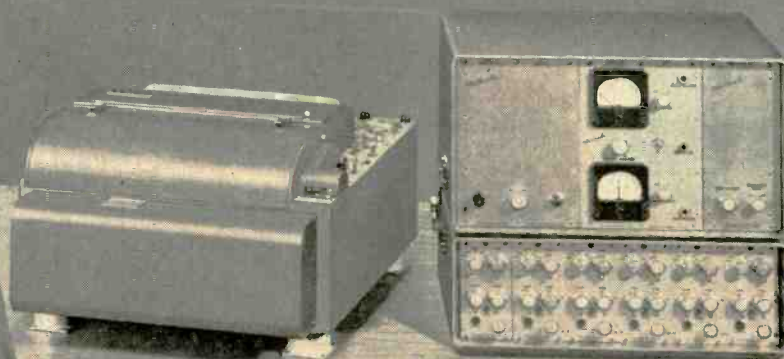

This engineer is fully equipped, with his Heiland Dynamic Recording System, to record a complete range of phenomena . . . strain, vibration, pressure, acceleration, temperature, impact and many others.

The 700-C Series Recording Oscillographs can put up to 60 traces on 12" wide recording paper at speeds from .03 to 144 in. per sec., with frequency response from DC to 3,000 cycles per second. Power supply is 28 volts DC or 115 volts AC. Both the oscillograph and the amplifier system (either carrier or linear/integrate) may be bench, shock, or vibration mounted, or installed in a standard relay rack without modification.

Whether your measuring and recording needs are for dynamic testing of guided missiles or aircraft; structural tests of buildings, bridges or ships; performance tests of heavy machinery or electrical equipment; riding quality evaluation of automobiles, trucks, or railroad coaches; physiological or medical research; or similar applications in all fields of industry, science and engineering—it will pay you to let a Honeywell Industrial Engineer show you why the Heiland System is unmatched for sensitivity, stability, and dependable performance. Call your nearest Minneapolis-Honeywell Industrial Sales Office today . . . and write for Bulletins 101K and 701K.

MINNEAPOLIS  
**Honeywell**

HEILAND INSTRUMENTS



5200 E. EVANS AVENUE • DENVER 22, COLORADO



# Electron Tube News

## - from SYLVANIA

Meeting Industry's New Challenges—Everywhere in Electronics

### IN COMPUTER TUBES . . .

Sylvania releases another new computer tube, the 7044, featuring high perveance

Advanced duo triode computer tube released by Sylvania, type 7044, features high perveance and dissipation capabilities and for many applications is a replacement for type 5687. Optimized design featuring leakage slots and the best alloys to preclude interface resistance contribute to a long and stable life.

Type 7044 supplements Sylvania's extensive line of tubes for computer applications which includes types 5844, 5963, 5964, 5965, 6211, 6350, 6814, 7AK7, 6145, 6888 and 5915A.

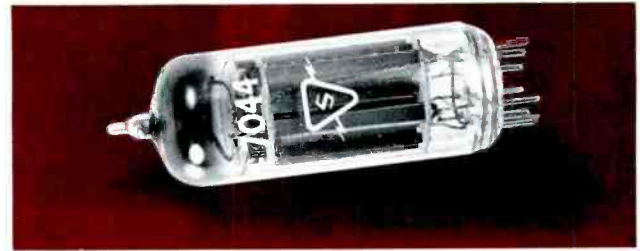

#### CHARACTERISTICS

##### RATINGS:

Heater Voltage . . . . .	(Series) . . . . .	12.6 Volts
	Parallel . . . . .	6.3 Volts
Heater Current . . . . .	(Series) . . . . .	450 Ma
	Parallel . . . . .	900 Ma
Plate dissipation per section . . . . .		4.5 Watts
Total plate dissipation . . . . .		8.0 Watts

##### TYPICAL CHARACTERISTICS:

Plate Voltage . . . . .	120 Volts
Grid Voltage . . . . .	-2 Volts
Plate Current . . . . .	36 Ma
Transconductance . . . . .	10,000 umhos
Amplification Factor . . . . .	19
Plate Resistance . . . . .	1,900 Ohms
Grid Voltage for $I_b = 200 \mu a$ ( $E_b = 150V$ ) . . . . .	-12 Volts
Plate Current ( $E_b = 90 V$ $E_c$ adjusted for $I_c = +250 \mu a$ ) . . . . .	50 Ma

### IN RELIABLE TUBES . . .

Sylvania's Gold Brand means extra dependability and reliability

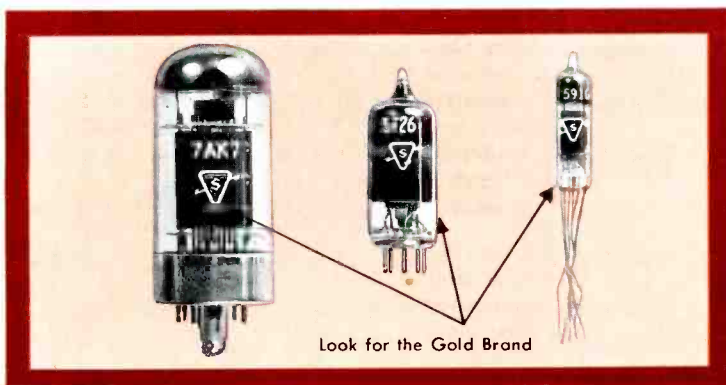

Now all Sylvania reliable receiving tubes are distinguished by the famous Gold Brand that already identifies the premium dependability of Sylvania subminiatures. The Gold Brand assures you of airborne and computer tubes with extra accuracy and dependability.

Sylvania Gold Brand tubes meet extra critical specifications throughout the entire tube-making operation. This extensive quality control is possible because Sylvania itself furnishes nearly every tube part. As a result, extra-critical specifications can be applied to the production of components throughout the manufacturing of tubes.

### IN TV PICTURE TUBES . . .

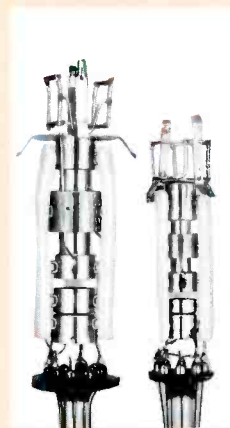

**New non-ion trap electron guns reduce tube length, eliminate external ion trap magnet**

Sylvania, trendsetter in electron tube design, offers two new improvements for television picture tubes:

- For 110° deflection—a small neck, non-ion trap gun with electrostatic focus
- For 90° deflection—a standard neck non-ion trap gun with electrostatic focus.

New Sylvania non-ion trap electron guns for 90° and 110° deflection with electrostatic focus.

Both new guns permit reductions in overall tube length of up to a full inch. They also make possible important cost savings by eliminating the need for external ion trap magnets.

The small neck gun for 110° deflection is available in the conventional base design with flexible stem leads or in the rigid pin base design with nylon cap.

# Meeting Industry's New Challenges—

## IN DYNAMIC TESTING . . .

### Sylvania expands its Dynamic Testing Program to include every key TV type

Sylvania's expanded dynamic testing program now covers every important family of tube types used in today's critical TV receiver circuits. Individual Sylvania receiving tube types are evaluated in actual circuit environments that simulate current TV set designs. This extra quality check substantially reduces line rejects for receiver manufacturers and gives greater reliability and improved TV set performance at lower cost.

Sylvania's Joint Engineering and Manufacturing Committee, JEMC, meets weekly to keep testing specs current. The group, made up of key engineering and manufacturing management personnel, establishes specifications that assure better performance levels under actual operating conditions.

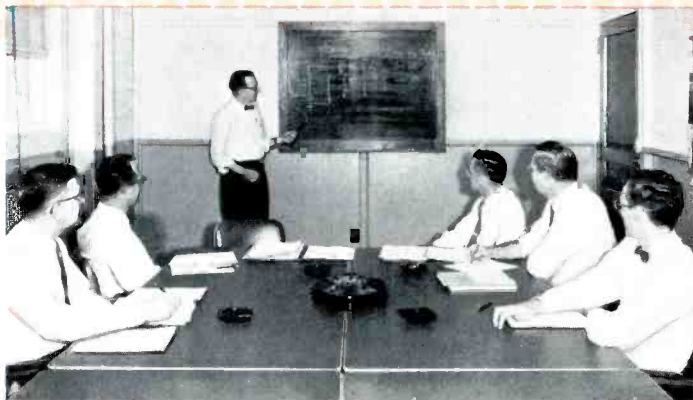

JEMC group, comprised of top engineering and production personnel in Sylvania's receiving tube operations, sets standards for the Dynamic Testing Program.

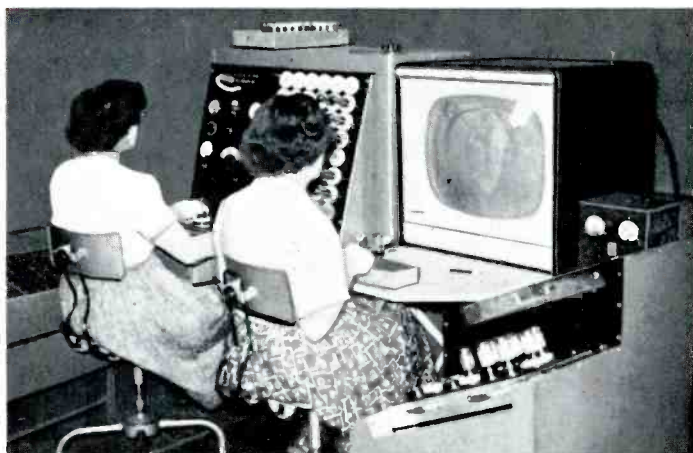

Sylvania tubes undergo arc tests in TV receiver circuits as part of its extensive Dynamic Testing Program.

## IN ADVANCED DESIGN . . . new filament designed for 1B3GT and its new short version, type 1G3GT



New heater design shown at right



Sylvania introduces a new coil filament design that improves the performance and extends the life of the standard 1B3GT. This new development replaces the conventional filament shield with a hooked coil design that reduces shorts and arcing and increases emission.

Sylvania's new 1G3GT, a miniaturized version of the 1B3GT, incorporates the new filament coil design, is a full  $\frac{1}{2}$  inch shorter in overall length, and exhibits the same characteristics as the 1B3GT.



## IN 110° DEFLECTION TUBES . . . New TV Deflection Pentode

Sylvania offers a new tube development, type 12DW5, to meet the requirements for large-screen 110° vertical deflection. It also has application in 110° off-the-line circuits.

This new beam power amplifier with a T 6 $\frac{1}{2}$  bulb size, is an original Sylvania design. It is already creating interest in the TV industry

for many 1958 receiver designs by leading television manufacturers.

For series-string circuits, the new 12DW5 features high peak-positive plate voltage, high zero bias current and adequate plate and screen dissipation. To supplement the 12DW5, Sylvania offers the 6DW5 with a 6.3-volt, 1.2-ampere heater characteristic.

#### Vertical Deflection Ratings (Pentode Connected)

Plate Voltage	330 Volts Max.
Grid No. 2 Voltage	220 Volts Max.
Peak-Positive Pulse	
Plate Voltage (absolute max.)	2200 Volts
Plate Dissipation	11 Watts Max.
Screen Dissipation	2.5 Watts Max.
Zero Bias Characteristics (Instantaneous Values)	
Plate Voltage	60 Volts
Grid No. 2 Voltage	150 Volts
Grid Voltage	0 Volt
Plate Current	260 Ma
Grid No. 2 Current	20 Ma



# Everywhere in Electronics

## —IN GUIDED MISSILE TYPES

**... Structural advantages  
earmark Sylvania tubes  
expressly designed  
for guided missile use**

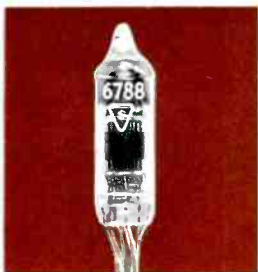

Possibly the biggest single factor behind the wide acceptance of Sylvania's Guided Missile subminiature tubes is the fact that each type was designed from start to finish under a new philosophy born of thorough investigation of Guided Missile requirements.

From closer control of raw materials to tighter parts tolerances and new manufacturing techniques, nothing was spared to design and produce the most missile-worthy tubes available.

### Wider grid-to-cathode spacing

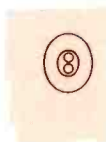

Consistent with tube functioning requirements optimum grid-to-cathode spacing provides greater protection against flicker shorts and minimizes vibrational noise.

### Adequate mica bearing surfaces



Tight, solid fitting is achieved between mica and cathode and mica and grid side rods through close parts tolerances and optimized bearing surface between the parts and mica.

### Shortest mica-to-mica spacing



Shortened mount adds structural rigidity and relocates natural resonances beyond the frequency range encountered in missile operations.

### Plate tabs and bent stems



Whenever possible, plate tabs are used and stem leads are bent, eliminating extra connectors and welds. A more rigid mount and improved reliability are achieved.

### Lowest mica-to-header spacing



This structural advantage is inherent in the button-header design which makes possible shorter spacings without interfering with tube assembly.

### Special bulb glass



Special new glass is employed in the guided missile tubes. The new hard glass makes possible bulb temperatures of 250° C. at a plate voltage of 250 volts.

## "NEW CONCEPT" BULB

**... a Sylvania refinement  
contributing to greater  
tube reliability**



Uniform wall thickness is maintained through "new concept" bulb fabricating techniques.

The new concept bulb is a typical Sylvania refinement which places greater controls over raw materials and physical tolerances.

From header to top seal, the new concept bulb is controlled for uniform wall thickness. The combination of more uniform bulb and closer mica spacing tolerances provides a tighter fitting, more rugged mount.

Postage  
Will be Paid  
by  
Addressee

No  
Postage Stamp  
Necessary  
if Mailed in the  
United States

### BUSINESS REPLY CARD

(First Class Permit No. 46687, New York 19, N. Y.)

SYLVANIA ELECTRIC PRODUCTS INC.

1740 Broadway

New York 19, N. Y.

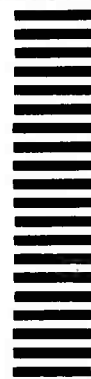

# Meeting Industry's New Challenges —Everywhere in Electronics

## IN 12-VOLT HYBRID TYPES . . .

**Sylvania's three new tubes,  
12CX6, 12AL8 and 12DL8, meet needs of  
1958 auto radio designs**

Three new 12-volt hybrid receiving tubes from Sylvania are becoming the mainstays in 1958 auto radio designs. They are types 12CX6, 12AL8 and 12DL8.

Type 12CX6, a new rf-if pentode, is a Sylvania original design that is becoming one of the most popular auto tubes in 1958 lines. It has high transconductance of 3,100 micromhos and high plate resistance which is

relatively unaffected by variation in the automobile supply voltage.

The 12AL8 is a medium mu triode and space-charged tetrode. It can be used as an audio amplifier and a transistor driver, or a trigger tube in remote control sets.

The 12DL8 is a new duo diode and space charge tetrode for transistor driver service and other applications.

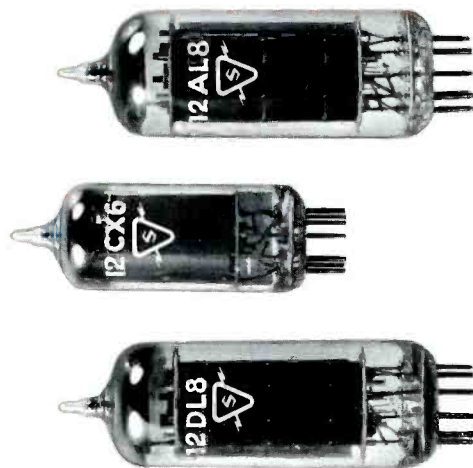

Three new 12-volt hybrid tubes from Sylvania for 1958 auto radio designs.

## IN SPECIAL CRT'S

**Expanding CRT program produces Type 5UP1—  
more to come as development continues**

Sylvania announces the availability of the Type 5UP1 general-purpose cathode-ray oscilloscope tube. It's among the first in Sylvania's plans to enter the special CRT program on a full-scale basis. Already in various stages of development and planned for early production are

such cathode-ray types as the 3JP7, 3RP1, 5AHP7A, 7ABP7A and 12ABP7A.

To meet its projected goals, completely separate development and production facilities have been established to meet industry's special needs.



# SYLVANIA

Please send additional information on the items checked below.

- Computer type 7044
- Type 12DW5—6DW5
- Type 1G3GT
- Guided Missile types
- Hybrid auto radio types 12CX6, 12AL8, 12DL8
- Special purpose cathode-ray tubes
- Non-ion trap TV picture tubes

Name \_\_\_\_\_

Address \_\_\_\_\_

Company \_\_\_\_\_

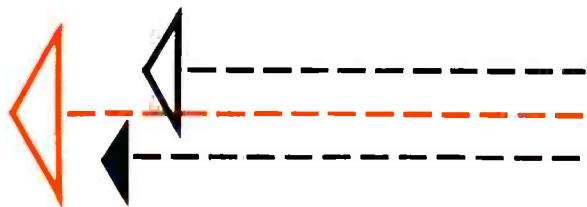

**Use this handy  
business reply card  
to request  
additional information  
on these important new  
Sylvania developments**



# NO MORE EXTERNAL BOOSTER AMPLIFIERS...

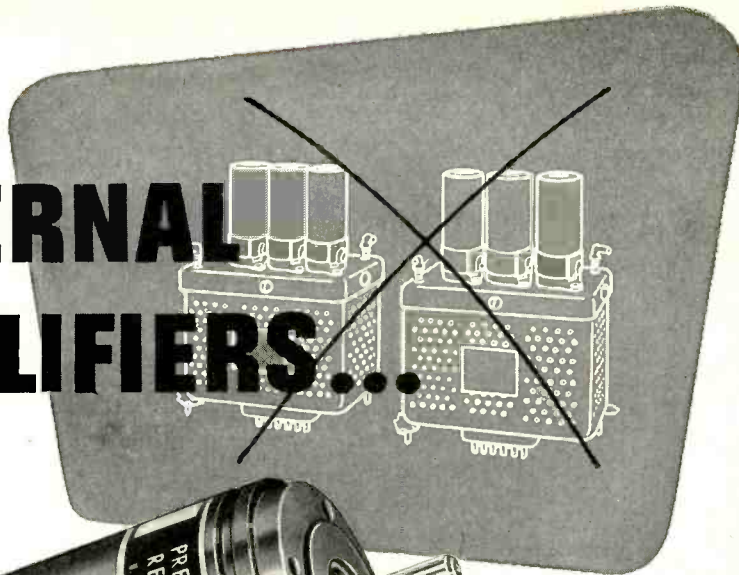

## with the new combination resolver-booster

by **Reeves**  
INSTRUMENT CORPORATION

### specifications

- Transformation ratio:  $1.000 \pm .001$
- Phase shift:  $0^\circ \pm 3'$
- Functional accuracy: 0.1%
- Input impedance: over 8 megohms
- Frequency: 400 c.p.s.  $\pm 5\%$
- Max. amplitude: 14 V. r.m.s.
- Temp. range:  $-55^\circ \text{C. to } 80^\circ \text{C.}$
- Power requirements:  
30 V. d.c. @ 6 ma. per amplifier

VISIT OUR EXHIBIT  
BOOTH NOS. 2421-2422  
WESCON SHOW  
San Francisco, August 20-23

### REEVES CONTINUOUS RESOLVER CHECKER

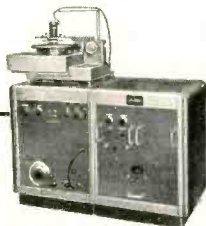

Provides continuous  $360^\circ$  check on resolver functional accuracy, and yields permanent record of results.

### An outstanding advance in MINIATURIZATION without sacrifice of performance or precision.

Shown FULL SIZE in the illustration above, this latest Reeves achievement in miniaturization for airborne applications takes up a fraction of the space occupied by a conventional resolver with external boosters. Yet performance, accuracy and dependability are in every way equivalent or better.

The new Reeves Combination Resolver-Booster consists of the time-proven R151 Precision Resolver with two PLUG-IN TRANSISTORIZED BOOSTER AMPLIFIERS built onto it as shown. The amplifiers provide standardization for transformation ratio and phase shift over a wide range of temperatures. Specifications given are maintained for production units without culling. Additional data on request.



9RV57

## REEVES INSTRUMENT CORPORATION

A SUBSIDIARY OF DYNAMICS CORP. OF AMERICA, 201 EAST 91st ST., NEW YORK 28, N. Y.

# *S.S. White*

## Flexible Shafts

### Make Operations

### Easier!



The manufacturer of this hue control for a color TV set uses a standard S.S. WHITE FLEXIBLE SHAFT to cope with a 90° turn. The shaft needs no alignment... can be quickly and easily installed. Costs are lower... manufacturing is simpler... assembly operations are easier, faster.

You can often reduce a complex system of gearing, universals and other parts to ONE FLEXIBLE SHAFT! Flexible shafts also make better designs possible... allowing new freedom in locating connected members to save space and facilitate operation and servicing.

For many years, these versatile shafts have been making industrial operations easier. They are tough and rugged... yet have the sensitivity you need for delicate adjustments. Design engineers and manufacturers discover new uses for S.S. WHITE FLEXIBLE SHAFTS every day. Can your product be improved by a simple... better... less costly way of transmitting power or remote control? Our engineers will be glad to work out a flexible shaft application with you. Just write to

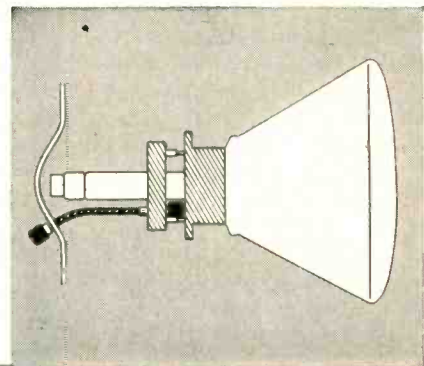

*S.S. White*

FIRST NAME

IN FLEXIBLE SHAFTS



*USEFUL DATA* on how to select and apply flexible shafts. Write for Bulletin 5601.

S. S. White Industrial Division, Dept. E, 10 East 40th St., New York 16, N. Y. Western Office: 1839 West Pico Blvd., Los Angeles 6, Calif.



# MOLDED

## COMPOSITION

## ELEMENT



Twice Actual Size

## POTENTIOMETERS

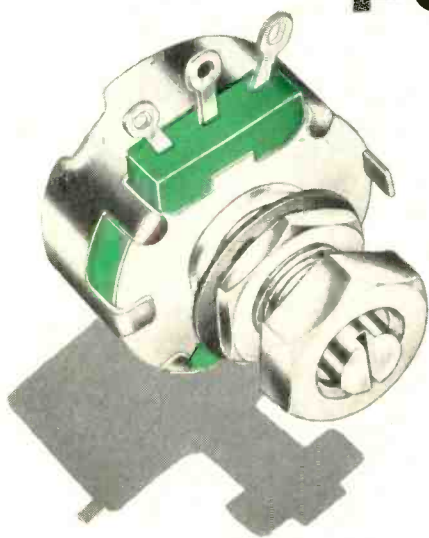

Write for detailed literature. Let us quote on your requirements.

1. Pre-molded and pre-selected resistance element.
2. Molded control base affording exceedingly low conductance, particularly in the presence of high humidity.
3. Single-member carbon contact, providing contact with resistance element and collector terminal, simultaneously.
4. No metal-to-metal movable contacts. Exceptionally long life.
5. "Zero backlash" or "Zero rock" shaft-to-contact assembly. Provides maximum order of "setability."
6. Gold-plated terminals insure solderability.
7. Shafts provided with grease seal, thus excluding moisture.
8. Flexible design readily permitting various mechanical adaptations.
9. No visible openings.
10. No rivets. Terminals permanently molded in resistance element and control base.
11. Mating surfaces of housing are sealed to prevent entrance of dust and moisture.
12. Full 2-watt rating at 70° C.
13. High order of resistance stability.
14. Salt-spray corrosion resistant.



**CLAROSTAT MFG. CO., INC., DOVER, NEW HAMPSHIRE**

*In Canada: Canadian Marconi Co., Ltd., Toronto 17, Ont.*

Using the diffused-meltback process

# G.E. gets the most from silicon...

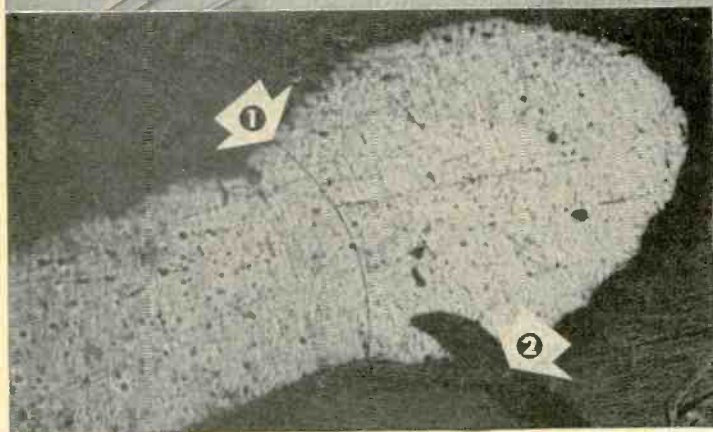
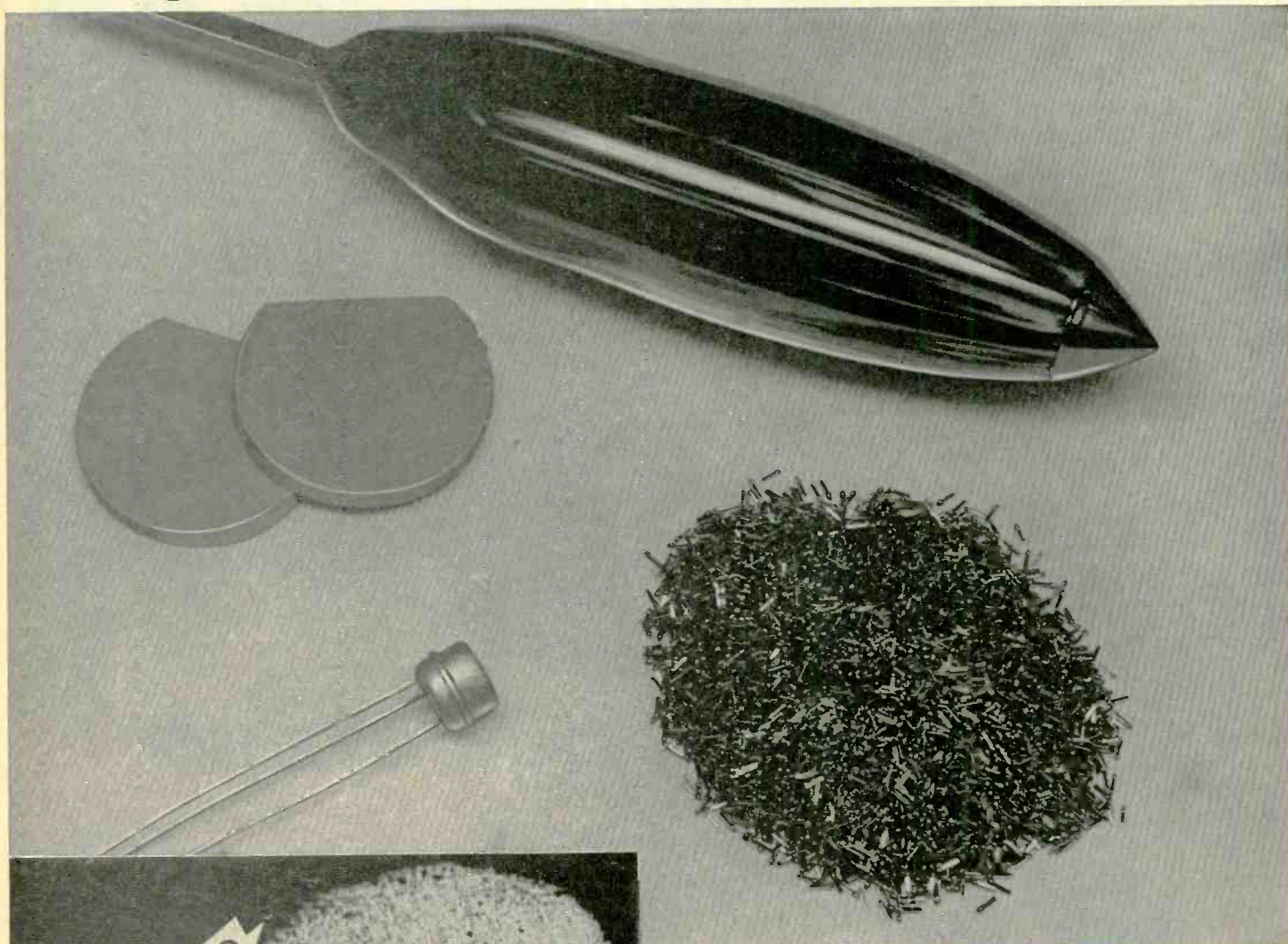

Before going through the diffused-meltback operation, a crystal of silicon is sawed into wafer-form: wafers are then diced to produce 4000 to 5000 individual silicon bars. Photomicrograph at left shows size-comparison of a silicon NPN bar, or pellet, with human hair (Arrow 2). "Tear drop" at end of bar is formed during meltback process. Micro-thin base, or "P", region (Arrow 1) is created through G-E diffusion technique. Base regions of 2-micron size are made with relative ease.

Curves illustrating impurity distribution after diffusion. P-type impurities in the high concentration side of the meltback junction diffuse, within solid semiconductor, into "plateau" region of low impurity concentration. High resistivity "plateau" contributes to elimination of punch-thru effects.

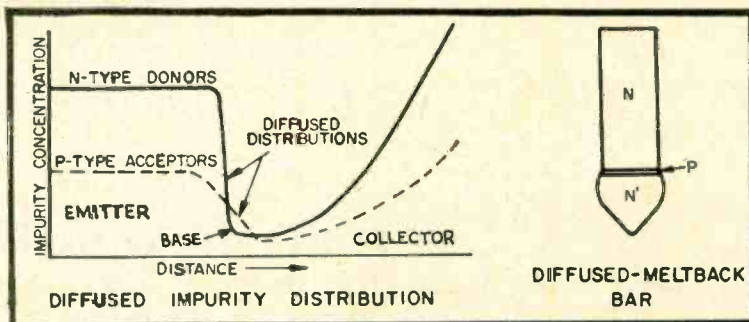



# to put the most into transistors

**High degree of uniformity and control in junction formation.** General Electric's diffused-meltback process was developed by Dr. I. A. Lesk of the G-E Advanced Semiconductor Laboratory. The development came about as the result of Dr. Lesk's efforts to create a transistor manufacturing process that would yield high-quality results at reasonable cost.

Not only does the G-E diffused-meltback process result in a maximum number of transistors from a single crystal (4000 to 5000 NPN transistors), but it offers an extremely high degree of uniformity and control in transistor junction formation.

**Opens the door to high frequency performance.** Diffusion of a melted-back silicon bar, or pellet, is the final step in the diffused-meltback process. It's the stage in which the micro-thin base, or "P" region is formed, establishing the final NPN transistor structure. Because the actual diffusion is accomplished over a high temperature heating cycle lasting several hours, the need for split-second accuracy is eliminated. The result is a high degree of process control.

By proper choice of the initial impurity concentrations and the time and temperature of the diffusion cycle, heavily-doped base regions as thin as 2 microns are easily obtained. *These micro-thin, uniform base regions are the "open-sesame" to ex-*

*tremely reliable high frequency transistor performance.*

**High current gain.** Silicon NPN transistors feature inherent high current gains and high frequency cut-offs. The diffused meltback process permits mass production, since it combines the principles of impurity segregation and solid-state diffusion.

G-E silicon NPN transistors are nominally rated for 25 megacycles, but with useful gain to 50 megacycles—the highest frequencies offered by any mass-produced silicon NPN triode on the market today. All production units are aged at extremely high temperatures for over 150 hours. This is to provide maximum stability of  $I_{co}$  and current gain (beta).

The header assemblies of G-E silicon NPN transistors are constructed of high-purity materials. A gold-silicon alloy is used for end connections: the base lead is pure aluminum. There are no solders or fluxes, eliminating any danger of transistor "sleeping sickness" caused by corrosion at soldered junction points.

**Outstanding For Switching Applications and Linear Amplifier Use.** The gold-alloy mountings, with a melting temperature of over 350°C represent the lowest melting point of the entire transistor assembly structure. The G-E Series 4JD4A silicon transistors provide reliable operation to 150°C, with storage temperatures to 200°C.

With well-controlled high frequency characteristics and a low saturation resistance of 20 ohms, G-E silicon NPN transistors are "naturals" for switching applications and linear amplifier use.

**Would you like complete specification information? Please contact your nearest G-E Semiconductor Products district office, or write to General Electric Company, Semiconductor Products, Section S2587, Electronics Park, Syracuse, N. Y.**

#### Ordering Data—G-E Silicon NPN Transistors

##### High Frequency Amplifier Type

ask for: **2N429** (formerly 4JD4A2)

##### Computer DCTL Type

ask for: **2N430** (formerly 4JD4A3)

##### General-Purpose Amplifier Types

ask for:		Beta
	<b>2N431</b> (formerly 4JD4A4)	9 to 30
	<b>2N432</b> (formerly 4JD4A5)	20 to 55
	<b>2N433</b> (formerly 4JD4A6)	45 to 100



View of uncapped G-E silicon NPN diffused-meltback transistor, showing mounted silicon bar with aluminum base lead connected. Bar ends attached using a gold-alloy mounting technique. No solders or fluxes are used.



Diffusion furnace. Operator places quartz vials, with large quantity of silicon bars, in furnace. Diffusion occurs through high-temperature heating cycle lasting several hours.

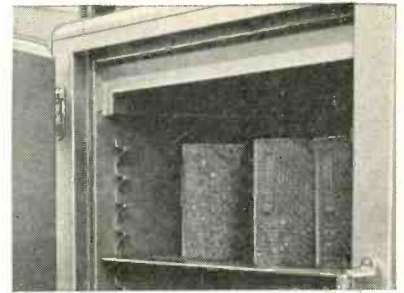

An aging oven in which G-E silicon NPN transistors are aged at extremely high temperatures for over 150 hours. Provides maximum stability of  $I_{co}$  and current gain (beta).



*Progress Is Our Most Important Product*

**GENERAL  ELECTRIC**

ARC selects

# FERRAMIC<sup>®</sup> CORE

for Automatic Direction Finder

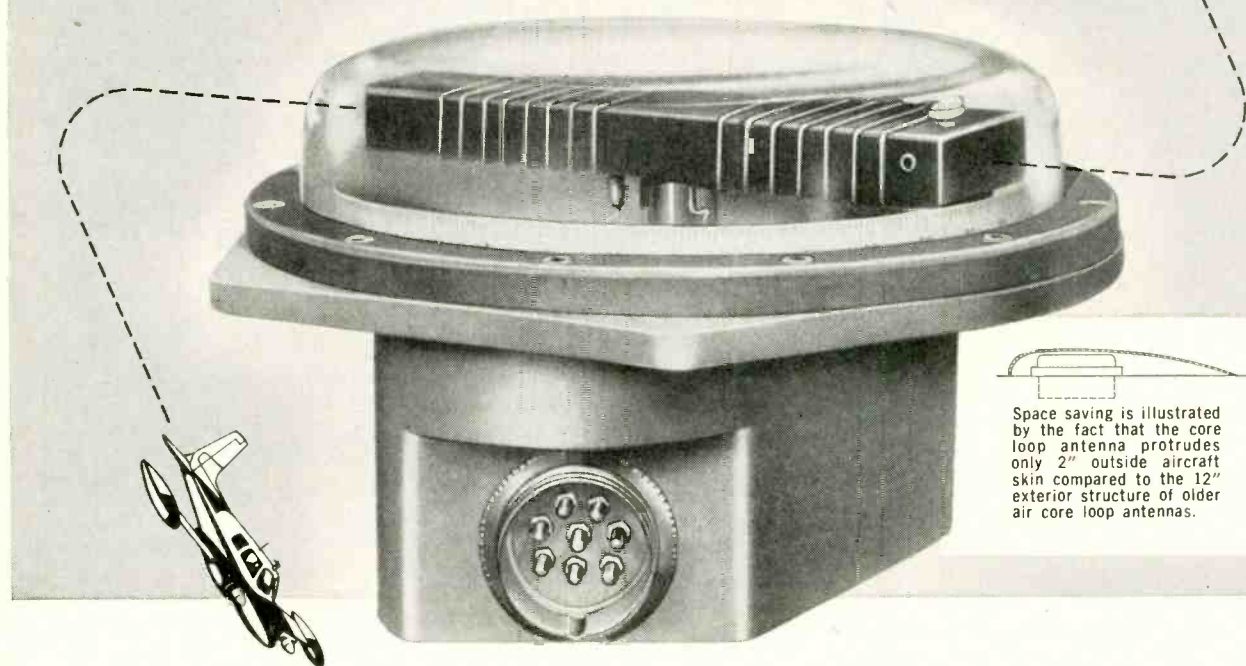

Space saving is illustrated by the fact that the core loop antenna protrudes only 2" outside aircraft skin compared to the 12" exterior structure of older air core loop antennas.

## Streamlined loop design saves weight, reduces air drag and increases sensitivity

Aircraft Radio Corp. selected General Ceramics Ferramic "E" Material for their new sub-miniature direction finder because it permitted a new concept of aircraft antenna design. Weight reduction of 80%, less air drag due to elimination of the cumbersome air core loop, and 50% lower cost were

accomplished. Sensitivity was greatly increased. When your application involves magnetic material from 10 kcs. to 20,000 mcs. — ask the General Ceramics engineering advisory service for help in solving your problem. Address inquiries to General Ceramics Corporation, Keasbey, N. J.—Dept. E.

### GENERAL CERAMICS

Industrial Ceramics for Industrial Progress... Since 1906

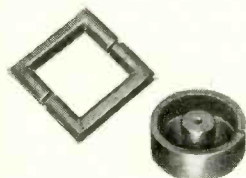

FERRAMIC CORES

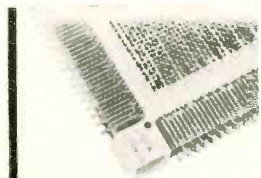

MAGNETIC MEMORY CORES AND PLANES



PRECISION STEATITES

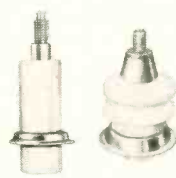

"ADVAC" HIGH TEMPERATURE SEALS



SOLDERSEAL TERMINALS



NEWS ABOUT VARIAN STALOS \*

**NEW WIDE  
TUNING RANGE**  
Cavity tunable, depending  
on klystron used, between  
8200 and 10,000 Mc.

# HIGH STABILITY

\* Frequency stabilized local oscillators

## without electronic components

Here's a line of High Q cavities offering commercially practical frequency stabilized local oscillators utilizing direct cavity stabilization. These Varian Stalo cavities provide a high degree of short time frequency stability.

As an example, with the combination of a VA-1280B cavity and VA-201B klystron, a short term frequency stability of approximately one part in  $10^9$  has been achieved. The stabilization factor of the cavity is completely independent of the oscillator fluctuations or external disturbances — an important advantage over stabilization systems utilizing the feedback principle. Elimination of all electronic components except the klystron oscillator also affords greater reliability and longer life.

Varian Stalo Cavities, in models for C-band through  $K_a$ -band, offer stabilization factors (ratio of oscillator modulation sensitivity to modulation sensitivity of the stabilized oscillator) from 15 to over 100. Important applications include stabilization of signal sources in high power klystron transmitters... airborne uses in conjunction with receiver local oscillators... laboratory and test applications. Used with Varian's new highly stable reflex klystron oscillators, Varian Stalos provide stability comparable to that of many crystal controlled oscillators.

The combination of a VA-1281B cavity and a VA-201B reflex klystron will provide excellent long term stability. A long term stability of approximately  $\pm 1$  Mc, over a  $100^\circ\text{C}$  ambient temperature range, can be achieved with a well-regulated power supply.

**Cavities designed to meet specific requirements are available on special order. Complete Stalo packages are also available including power supply and klystron, with single-knob control over a limited tuning range.**



**X-Band Stalo Cavity VA-1280B**  
Shown with VA-201B klystron

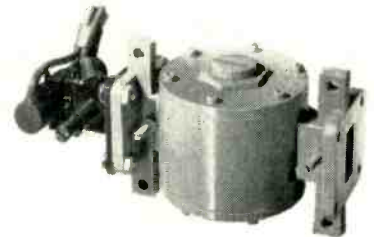

**X-Band Stalo Cavity VA-1281B**  
Shown with VA-201B klystron

**COMPLETE TECHNICAL DATA  
AND SPECIFICATIONS are now  
available.**

*Your inquiry is cordially invited.*

THE  
MARK OF  
LEADERSHIP



**VARIAN associates**

PALO ALTO 1, CALIFORNIA

Representatives in all principal cities

KLYSTRONS, TRAVELING WAVE TUBES, BACKWARD WAVE OSCILLATORS, LINEAR ACCELERATORS, MICROWAVE SYSTEM COMPONENTS,  
R. F. SPECTROMETERS, MAGNETS, MAGNETOMETERS, STALOS, POWER AMPLIFIERS, GRAPHIC RECORDERS, RESEARCH AND DEVELOPMENT SERVICES

# Need a "SPECIAL" TIMER ...need a "STANDARD"?

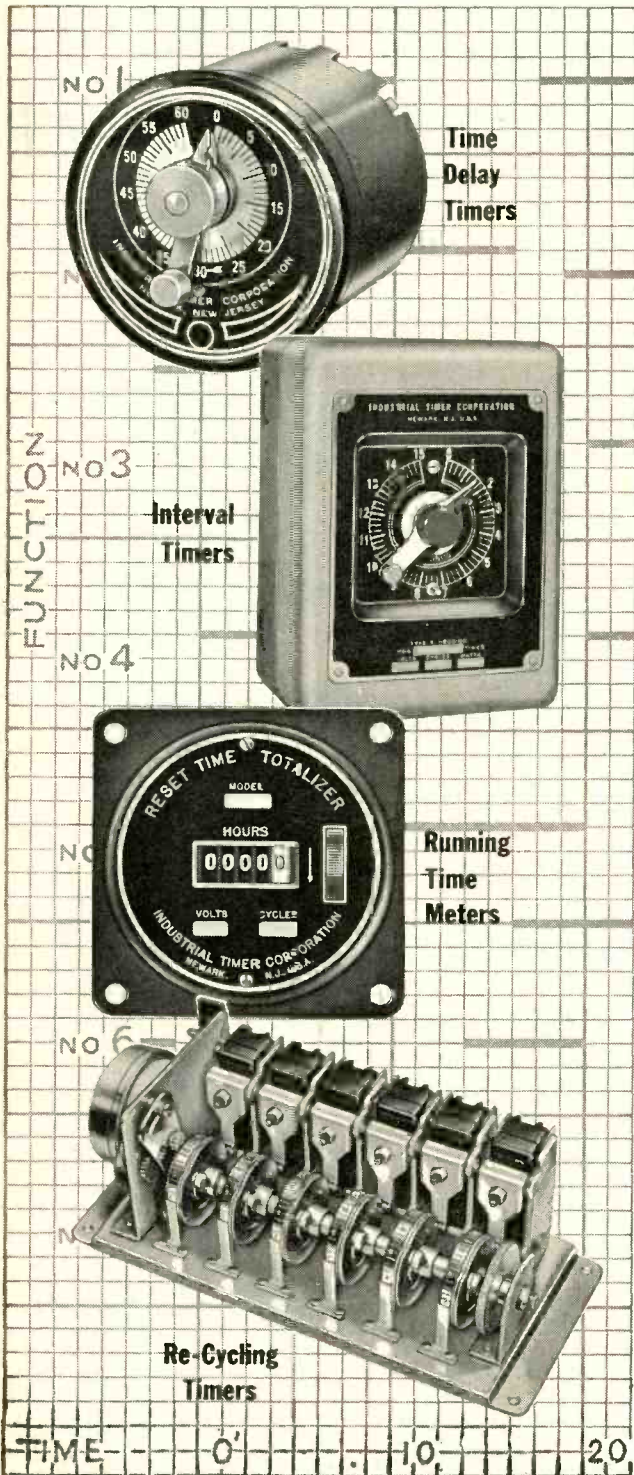

## Here's why WE can give you the fastest service

When you want a timer, you want one that fits your needs 100% — and you want it fast. Get in touch with Industrial and you'll get both. Because:

In our 20 years of experience, we have developed over a thousand combinations from our 17 basic types, to meet the widely varying needs of our customers. Therefore — many jobs that would seem to require a "special" timer are in fact a "standard" timer with us. Here is one tremendous saving of time for you.

When you do need a special timer, this same wealth of experience goes to work for you at once to design it. Our Engineering Department not only originates new designs, but also develops modifications for that purpose. That's why requests for special timers can be filled without delay.

Each method — designing for a standard timer or for a special timer — has its advantages. Designing for an already available timer means lower costs, faster service, simplified replacements.

Designing for a special timer has its advantages too. It means you'll fulfill your needs 100% — no need to limit your designing horizons. Either way — standard or special — you'll get the timer you want most promptly from Industrial.

Or perhaps you need quick service on timers for automatic controls. Here too Industrial Timer is your first source of supply. For in this field Industrial has a big head start. True, each automatic control job is a bit different from the rest. But the record shows that our years of timer experience has given us the special knowledge it takes to give you the right answers in near-record time.

So, for the utmost in all-round timer service, it's Industrial that offers you this outstanding combination: deliveries "Immediate on Standards . . . First on Specials." Plus the experience of one of the foremost group of timer engineers in the nation.

Timers that Control  
the Pulse Beat of Industry



**INDUSTRIAL TIMER CORPORATION**

1409 McCARTER HIGHWAY, NEWARK 4, N. J.



# "But I am constant as the northern star"

—Julius Caesar Act III Sc. 1

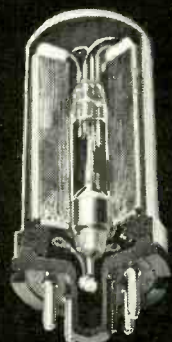

You know what to expect from CLARE Mercury-Wetted-Contact Relays—always. Their performance is **CONSTANT**.

**Constant contact stability**—No contact chatter—none at all.

**Constant contact resistance**—Repetitive measurements on individual relay contacts are constant to a few milliohms. Resistance of single contacts, including resistance of internal wiring between base terminals, ranges between 25 and 40 milliohms. Contact deterioration cannot occur in this relay.

**Constant operate time**—Varies by only about C.1 millisecond under constant drive conditions.

**Constant pull-in current**—Repetitive operating precision of given relay is within 1% of its minimum operating current. This precision is substantially independent of number of operations or ambient temperature.

**Constant adjustment**—Requires no maintenance whatever. No possibility of change in adjustment. This remains true even after thousands of millions of operations.

If you have a job for which none but the best relay is good enough, it can cost you much more to settle for less than this CLARE RELAY. For complete information contact your nearest Clare representative or address C. P. Clare & Co., 3101 Pratt Blvd., Chicago 45, Illinois. In Canada: C. P. Clare & Co., 659 Bayview Avenue, Toronto 17. Cable address: CLARELAY.

Send for CLARE Sales Engineering  
Bulletins Nos. 120 and 122

## CLARE RELAYS

FIRST in the industrial field

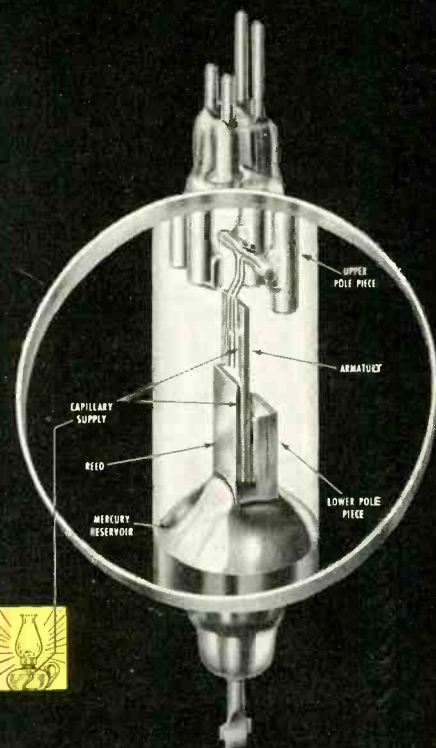

Contacts of CLARE Mercury-Wetted-Contact Relays are constantly renewed. By capillary action, like that of a lamp wick, a new film of mercury coats each contact with every make and break.



Drawings (left) from high-speed photographs show the cycle. (a) Filament of mercury forms between the contacts as they separate. (b) This becomes narrower in cross section and (c) finally parts at two points, allowing globule of mercury to fall out. Mercury flows up the capillary path, replaces amount lost, restores the equilibrium. (d) The momentary bridging of the parting contacts—and the extremely fast break that ends it—minimizes the arc and adds greatly to contact load capacity. Contact closure between the two liquid surfaces bridges mechanical bounce and prevents any chatter from appearing in the electrical circuit.



**Hermetically  
Sealed  
125°C**

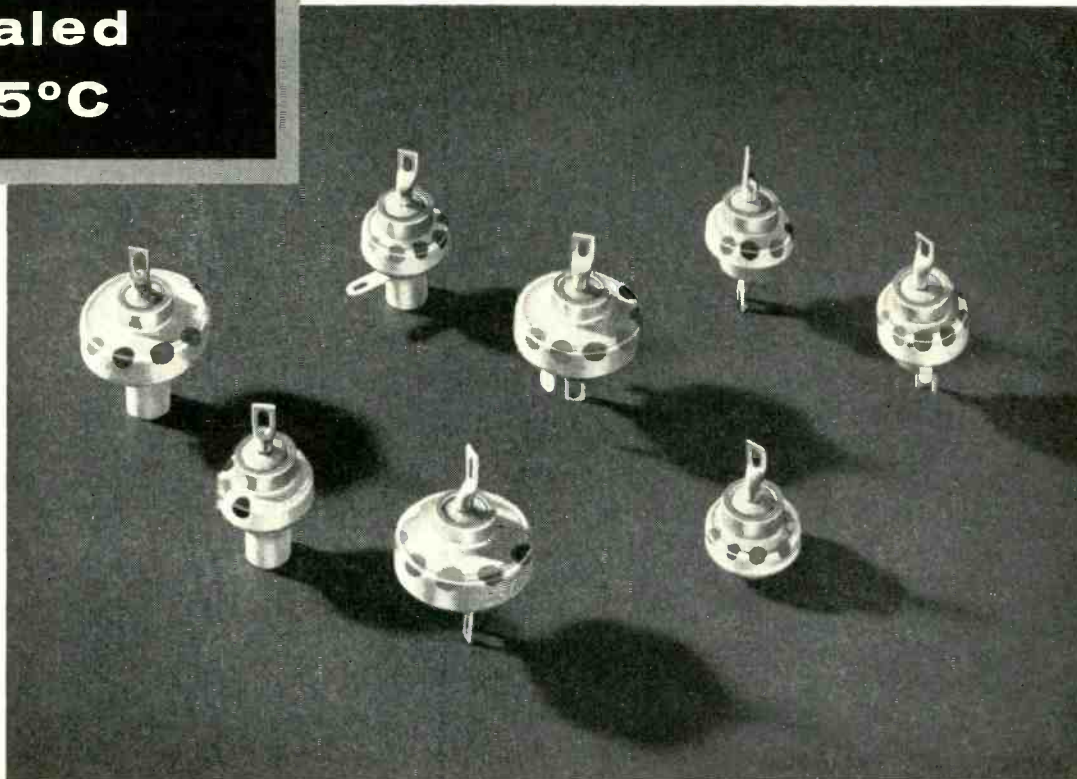

## ***SANGAMO SILVERED MICA BUTTON CAPACITORS***



### **HIGH RELIABILITY MANUFACTURING FACILITIES**

Sangamo's "controlled conditions" facilities for the exclusive manufacturing of high reliability capacitors assure really fine capacitors for your most critical military or industrial applications.

Sangamo's design engineers have developed these hermetically sealed mica button capacitors especially for high frequency applications under severe humidity and temperature conditions.

The unique internal design results in low inherent inductance—ideal for application at frequencies up to 500 megacycles per second in tuning, coupling and by-pass circuits. The silver plated case serves as both the low potential terminal and as an electrostatic shield.

These units meet all requirements for V.H.F. and U.H.F. applications and meet Joint Army-Navy specification MIL-C-10950B (proposed). Operating temperature range is from  $-50^{\circ}\text{C}$  to  $125^{\circ}\text{C}$ . Specify these high reliability capacitors for your most critical applications. Write for new Catalog 2311 on Sangamo Silvered Mica Button type capacitors.

**FIVE TYPES AVAILABLE**—Stand-off with ground lug, Stand-off without ground lug, Feed-thru without mounting lugs, Stand-off without pedestal, and Feed-thru with mounting lugs.

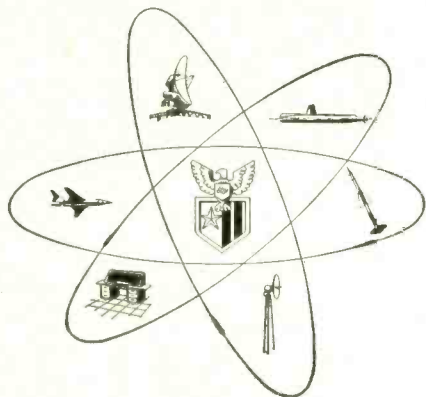

**SANGAMO ELECTRIC COMPANY**

*Electronic Components Division*

SPRINGFIELD, ILLINOIS

SC57-6



# Sperry's combination radar test sets integrate all testing functions

Faster, simpler radar maintenance is the pay-off with the Sperry Combination Test Sets. One set does the job of three or more standard test units but requires one-quarter the space and weighs half as much! Here are the five functions each Sperry test set performs:

**POWER METER:** Directly measures average power of radar transmitter with accuracy of  $\pm 1.0$  db.

**FREQUENCY METER:** Indicates directly the frequency of both receiver and transmitter.

**SPECTRUM ANALYZER:** Accurately displays power vs. frequency spectrum of transmitter signals from single or multi-pulse systems. Display is stable at all pulse widths and repetition rates.

**SYNCHROSCOPE:** Simple general-purpose synchroscope functions as an "A" scope and displays radar video signals or similar wave forms—no need for auxiliary synchroscope.

**SIGNAL GENERATOR:** Accurately and directly calibrated output signal level is variable over complete range. Choice of pulse, frequency or external modulation.

With no additional equipment you can also measure transmitter peak power, repetition rate, transmitter pulse width, T.R. recovery time, duplexer losses, transmission line VSWR. Designed for tough operating conditions, these sets comply fully with military specification MIL-T-945A. Your nearest Sperry district office will gladly supply you with complete operating data.

Visit our booths 2309-2310 at the Wescon Show.



Microline Model 570  
16 3/4" L x 15 3/4" W x 15 3/4" H

## COMPLETE LINE OF TEST SETS

Band	Microline* Model	Military Type	Frequency
L	670		400-450mc
S	590B	UPM-44B	2700-3500mc
C	551A	SPM-5	5100-5900mc
X	570	UPM-32	8500-10500mc
K	557		23500-24500mc
V	580A	UPM-14	34000-35600mc

\*T. M. REG. U. S. PAT. OFF.

MICROWAVE ELECTRONICS DIVISION

**SPERRY** *GYROSCOPE COMPANY*  
Great Neck, New York

DIVISION OF SPERRY RAND CORPORATION

Brooklyn • Cleveland • New Orleans • Los Angeles  
San Francisco • Seattle. In Canada: Sperry Gyro-  
scope Company of Canada, Ltd., Montreal, Quebec.

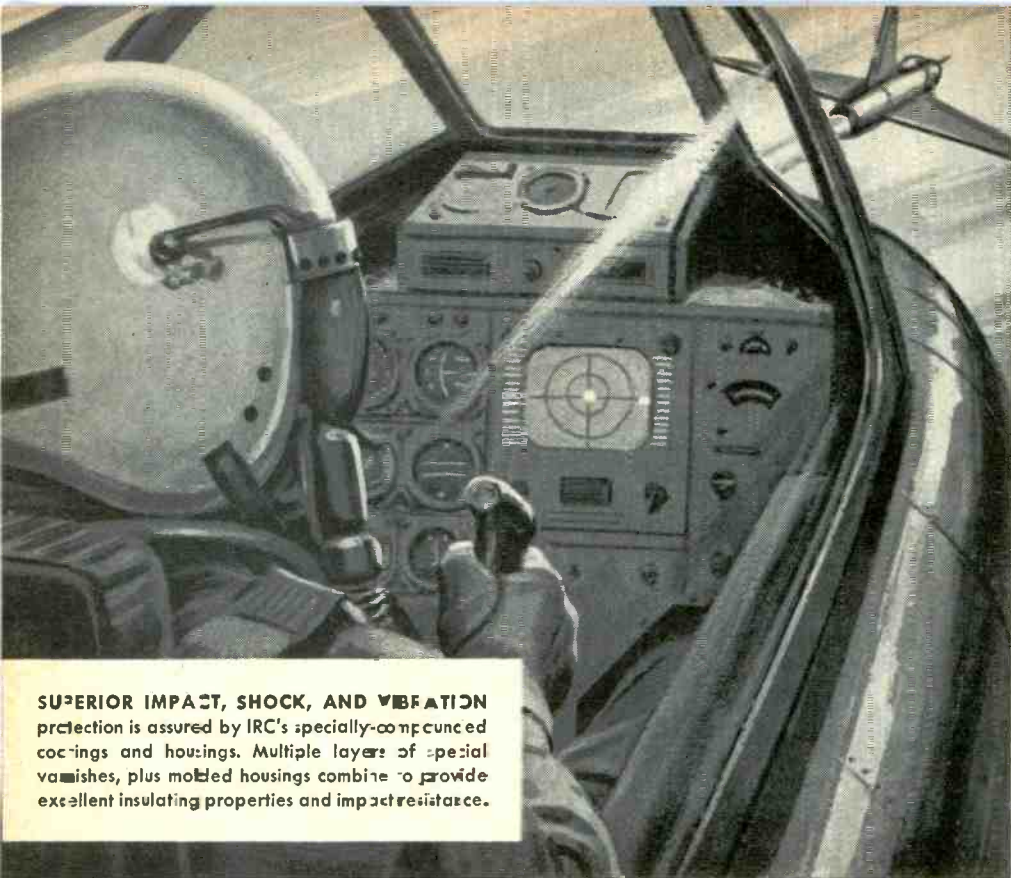

**SUPERIOR IMPACT, SHOCK, AND VIBRATION** protection is assured by IRC's specially-concocted coatings and housings. Multiple layers of special varnishes, plus molded housings combine to provide excellent insulating properties and impact resistance.

In a sense, a resistor is simply a mechanical device for packaging ohms. So it's easy to see why the materials entering into the mechanical package are extremely important to resistor performance. That's why more than one-third of the 200 technicians at IRC are occupied in developing insulating coatings and housings that give *extra* protection

## Extra **IRC**<sup>®</sup> resistor protection pays off ...but you pay no more for it!

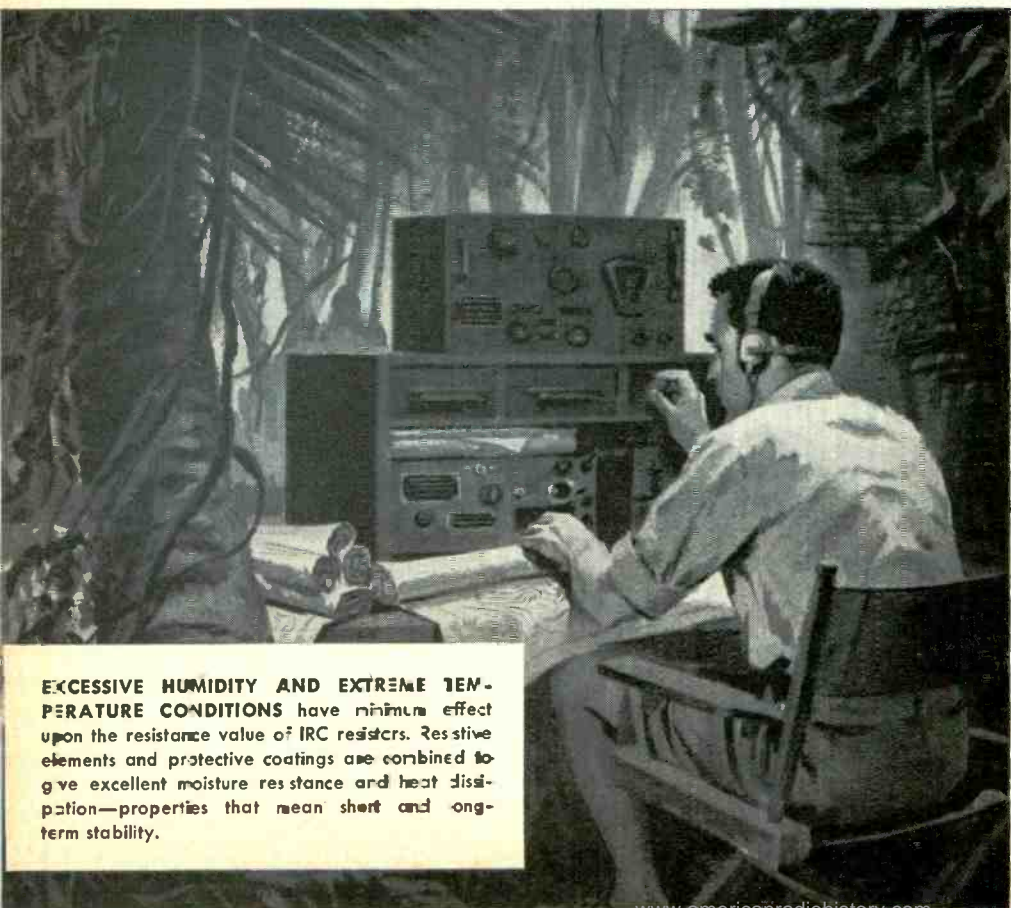

**EXCESSIVE HUMIDITY AND EXTREME TEMPERATURE CONDITIONS** have minimum effect upon the resistance value of IRC resistors. Resistive elements and protective coatings are combined to give excellent moisture resistance and heat dissipation—properties that mean short and long-term stability.

against mechanical damage, humidity effects, and temperature variations.

Out of this never-ending activity come coatings and molding compounds that are custom-tailored for each and every type of resistor. As a result, every IRC resistor gives far more protection from damage and ambient conditions than any other of its type!



# How IRC resistors give added protection

## molded resistors



TYPE B7 Fixed  
Composition Resistors



TYPE BW  
Insulated Wire  
Wound Resistors



TYPE MD  
Molded Deposited  
Carbon Resistors



TYPE PW  
Insulated Wire  
Wound Resistors

Plastic compounds used in IRC molded resistors are all specified by IRC to combine excellent insulating properties, moisture resistance, and impact resistance.

## varnish coated resistors



TYPE DC  
Deposited Carbon Resistors



TYPE MV High  
Voltage Resistors



TYPE MP High  
Frequency Resistors



TYPE HFR High  
Frequency Resistors

Where mechanical damage isn't a major problem, IRC resistors give excellent protection at lower cost through the use of IRC-developed varnish coatings. Because several layers are applied and cured under specially controlled conditions, these resistors offer superior humidity and temperature characteristics.

## cement insulated resistors



TYPE PWW TYPE PWW  
Power Wire  
Wound Resistors

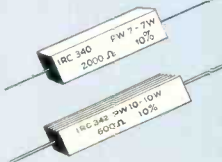

TYPES PW-3,  
PW-7 & PW-10  
Small Insulated  
Power Resistors

The special cement coatings used to insulate IRC power resistors give excellent mechanical protection. Type PWW Resistors, for example, withstand a transverse pressure of 25 pounds. These exclusive IRC cements also permit maximum heat dissipation and give superior moisture protection.

## impregnated and encapsulated resistors

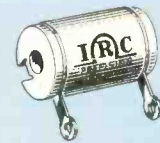

TYPE WWJ Precision  
Wire Wound Resistors

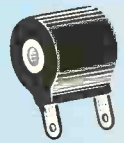

SERIES "PH"  
Encapsulated Precision  
Wire Wound Resistors

Type WWJ Resistors feature a special compound that thoroughly impregnates the winding and remains stable at varying temperatures. This compound not only gives maximum mechanical protection, but also serves as an insulating barrier and minimizes moisture effects. In IRC encapsulated resistors, the same epoxy resin is used for both the core and the outer housing, thus minimizing the effects of expansion and contraction due to various temperature conditions. This epoxy resin also imparts excellent insulating and moisture-resistant properties to the housing.

VISIT IRC  
BOOTH 521-522



Wherever the Circuit Sings  
1957 WESCON SHOW  
August 20-23  
San Francisco

IRC PLANTS—Asheville, N.C. • Boone, N.C.  
Burlington, Iowa • Philadelphia, Pa.  
Hycor Division, Sylmar, California  
Circuit Instruments Inc., St. Petersburg, Fla. (subsidiary)  
Hycor Company, Inc., Vega Baja, P.R. (subsidiary)

## INTERNATIONAL RESISTANCE COMPANY

Dept. 237, 401 N. Broad St., Philadelphia 8, Pa.  
In Canada: International Resistance Co., Ltd., Toronto, Licensee

Please send technical bulletins describing  Fixed Compositions  
 Deposited Carbons  Low Power Wire Wounds  Power Wire  
Wounds  High Voltage Types  High Frequency Types  Precision  
Wire Wounds  Encapsulated Precisions

Name \_\_\_\_\_

Company \_\_\_\_\_

Address \_\_\_\_\_

City \_\_\_\_\_ State \_\_\_\_\_

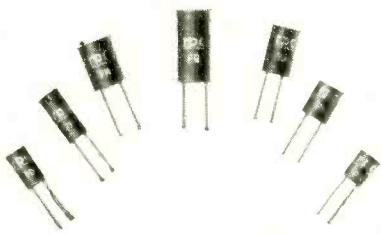

### Printed Circuit Precision Resistors

To meet the requirements for printed circuitry, RPC has developed Type P Encapsulated Wire Wound Precision Resistors. Miniature, single ended units designed for easy rapid mounting on printed circuit panels with no support other than the wire leads. Many newly developed techniques are employed in the manufacture of Type P Resistors. These units can be operated in ambient temperatures up to 125°C. and will withstand all applicable tests of MIL-R-93A, Amdt. 3. Available in 6 sizes, rated from 1/10 watt to .4 watt.  $\frac{1}{4}$ " diameter by  $\frac{3}{16}$ " long to  $\frac{3}{8}$ " diameter by  $\frac{3}{4}$ " long. Resistance values to 3 megohms. Tolerances from 1% to 0.05%.

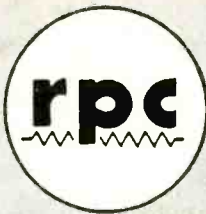

# HIGH QUALITY RESISTORS FOR ELECTRONICS

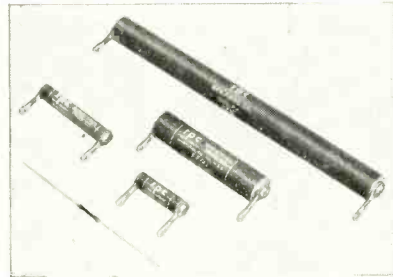

### High Frequency Resistors

Used where requirements call for very low inductance and skin effect in circuits involving pulses and steep wave fronts. Depending on size and resistance value, these resistors are usable at frequencies to over 400 mc. Resistance values range from 20 ohms to 100 megohms with tolerance of 20% to 5%. 2 types available.

TYPE F resistors (shown) in 8 sizes from  $\frac{9}{16}$ " long x 0.10" diameter to  $\frac{6}{12}$ " long x  $\frac{9}{16}$ " diameter, with lugs or wire leads. Power ratings  $\frac{1}{4}$  to 10 watts.

TYPE G resistors (not shown), in 6 sizes up to  $1\frac{1}{2}$ " long. Power ratings 10 to 100 watts.



### High Voltage Resistors

Type B Resistors are stable compact units for use up to 40 KV. These resistors are used for VT voltmeter multipliers, high resistance voltage dividers, bleeders, high resistance standards and in radiation equipment. They can be furnished in resistance to 100,000 megohms. Available as topped resistors and matched pairs. Sizes range from a 1 watt resistor 1 inch long x  $\frac{3}{8}$  inch diameter rated at 3500 volts, to a 10 watt resistor  $6\frac{1}{2}$  inches long x  $\frac{3}{8}$  inch diameter rated at 40 KV. Low temperature and voltage coefficients. Standard resistance tolerance 15%. Tolerances of 10%, 5% and 3% available. Tolerance of 2% available in matched pairs.

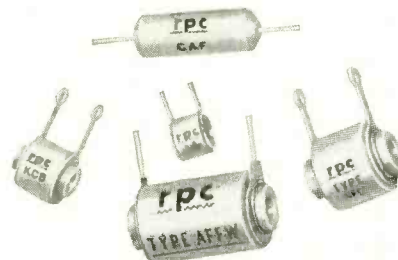

### Unsealed

### Precision Wire Wound Resistors

Unsealed precision resistors are wound on steatite forms and are used for all general requirements. They can be furnished with all resistance alloys in tolerances from 1% to .02%. These resistors will meet the requirements of MIL-R-93A, Amdt. 2, characteristic B. Special winding techniques, impregnation and thermal aging result in resistors of exceptional stability. They are available in a wide variety of sizes, styles and terminal types. Matched resistors, networks and special assemblies can be supplied.



### High Megohm Resistors

Type H Resistors are used in electrometer circuits, radiation equipment and as high resistance standards. Resistance available to 100 million megohms, ( $10^{14}$  ohms). For utmost stability under adverse conditions Type HSD and HSK Hermetically Sealed are recommended. Eight sizes from  $\frac{1}{4}$  inch to 3 inches long are available. Voltage rating to 15,000 volts. Low temperature and voltage coefficients. Standard resistance tolerance 10%. Tolerance of 5% and 3% available. Also matched pairs 2% tolerance.

RPC is a widely recognized supplier of high quality resistors to industry, Government Agencies and the Armed Forces. Advanced production methods, modern equipment and scientific skill enables RPC to manufacture resistors of highest quality in large quantities at reasonable cost. Modern manufacturing plant is completely air conditioned and equipped with electronic dust precipitators to insure highest production accuracy. RPC resistors are specified for use in instruments, electronic computers, radiation equipment, aircraft equipment and scientific instruments.

Test equipment and standards for checking and calibrating are equalled by only a few of this country's outstanding laboratories. Our ability to produce resistors of highest quality coupled with prompt delivery have established RPC as a leading manufacturer of resistors. Small or large orders are promptly filled.

Representatives in principal cities. For full information send for latest catalog.



### Wire Wound Precision Resistors

Type A Precision Resistors are widely used for all general requirements. They are available in a wide variety of sizes, styles and terminal types. They can be furnished with all resistance alloys in tolerances from 1% to .02%. Type A will meet the requirements of MIL-R-93A, Amdt. 2, Characteristic B. Special winding techniques, impregnation and thermal aging result in resistors of exceptional stability. Matched resistors, networks and special assemblies can be supplied.

# RESISTANCE PRODUCTS CO.

914 S. 13th Street  
HARRISBURG, PA.



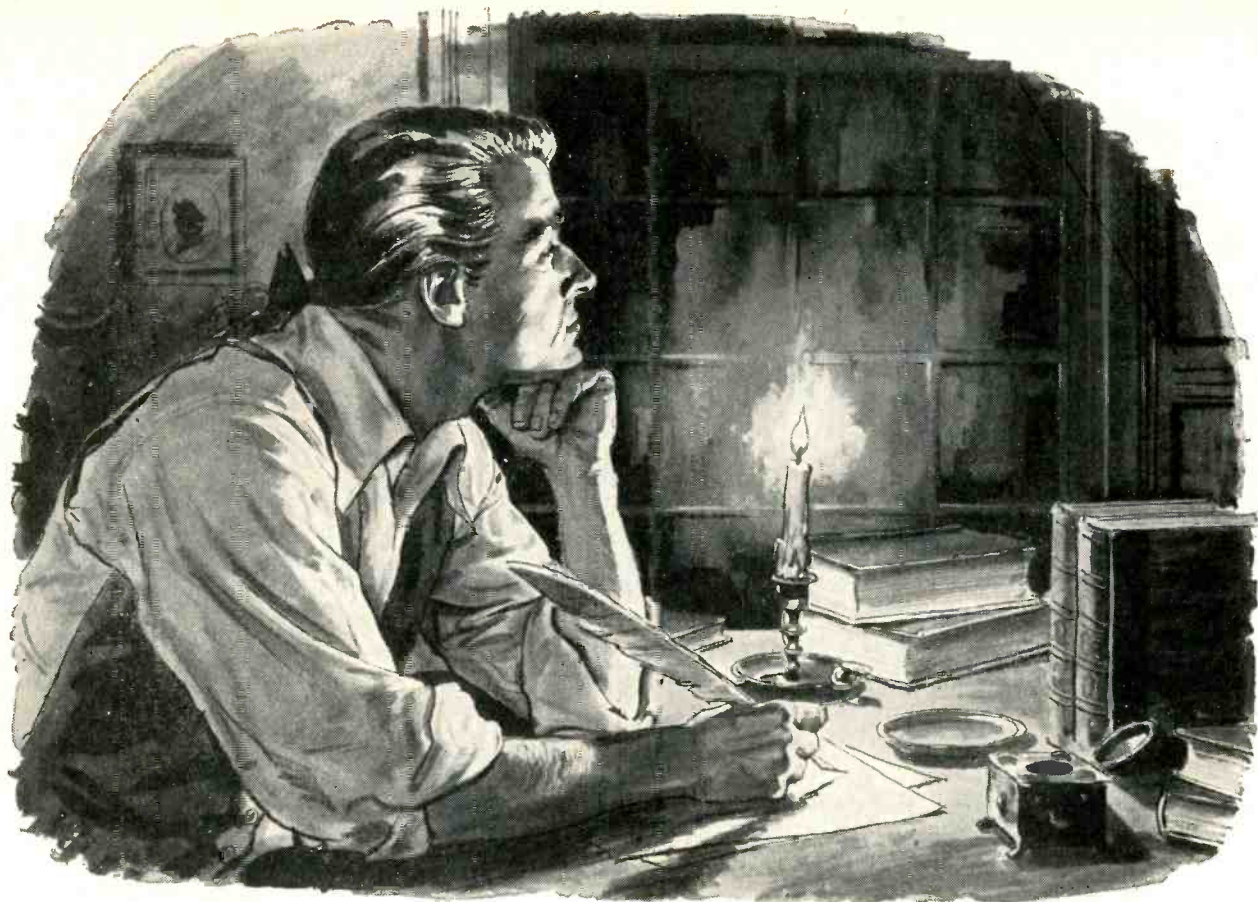

## Where Do Great Ideas Come From?

From its beginnings this nation has been guided by great ideas.

The men who hammered out the Constitution and the Bill of Rights were thinkers—men of vision—the best educated men of their day. And every major advance in our civilization since that time has come from minds *equipped by education* to create great ideas and put them into action.

So, at the very core of our progress is the college classroom. It is there that the imagination of young men and women gains the intellectual discipline that turns it to useful thinking. It is there that the great ideas of the future will be born.

That is why the present tasks of our colleges and universities are of vital concern to *every*

American. These institutions are doing their utmost to raise their teaching standards, to meet the steadily rising pressure for enrollment, and provide the healthy educational climate in which great ideas may flourish.

They need the help of all who love freedom, all who hope for continued progress in science, in statesmanship, in the better things of life. And they need it *now!*

If you want to know what the college crisis means to you, write for a free booklet to: HIGHER EDUCATION, Box 36, Times Square Station, New York 36, N. Y.



*Sponsored as a public service, in cooperation with the Council for Financial Aid to Education*

# Transitron

# Silicon Transistors

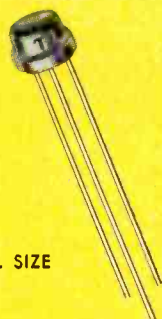

ACTUAL SIZE

## ... for high temperature operation

Transitron's NPN silicon transistors are designed for a wide range of small signal applications in the power range up to 200 mw. They will provide dependable operation up to 175°C in circuits such as RF and IF amplifiers, video and audio amplifiers, servo control, switching, and many others.

Manufactured by diffusion in the liquid phase during crystal growth, these transistors are essentially free of parameter drift and instability common in conventional grown junction transistors. Through close process control, these units have exceptionally low  $I_{co}$  up to their maximum voltage and temperature ratings. As a result, performance reliability can be achieved even at higher voltage levels.

For environmental stability, extensive temperature cycling and storage as well as mechanical and hermetic seal tests are included as a regular part of the manufacturing process.

Type	Minimum Common Emitter Current Gain, B	Maximum Collector Voltage V <sub>ce</sub> Peak (volts)	Typical Cut-off Frequency (mc)	Maximum Collector Cut-Off Current at 25°C at V <sub>ce</sub> Max. (ua)
ST42	40	45	11	.5
ST32	40	30	11	.5
ST12	40	15	11	.5
ST33	30	30	17	.5
ST13	30	15	17	.5
ST41	20	45	10	.5
ST31	20	30	10	.5
ST11	20	15	10	.5

Send for Bulletin TE-1353





## FEATURES . . .

- Low  $I_{cor}$ , typically under .02  $\mu a$
- Operation to 175°C
- 200 mw Power Rating
- High Frequency Operation
- High Temperature Tested
- Excellent Stability
- Welded Hermetic Seal

COMMON EMITTER OUTPUT CHARACTERISTICS

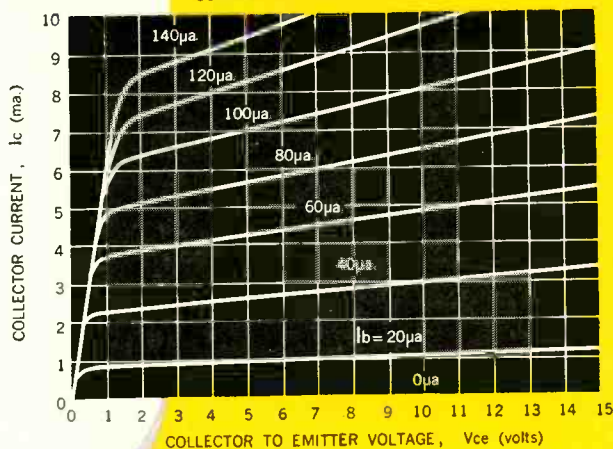

TYPICAL COLLECTOR CUTOFF CHARACTERISTICS

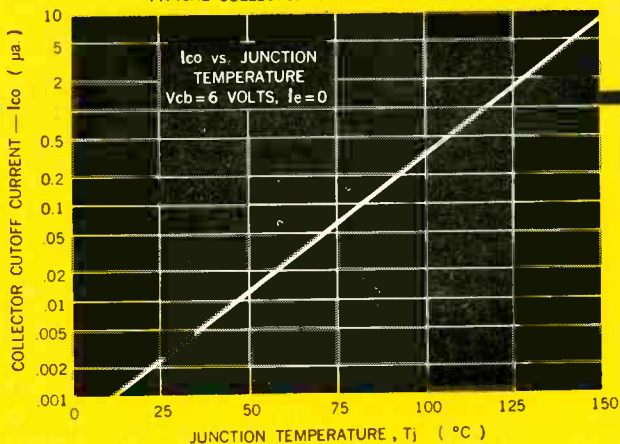

Visit Booth 2801-02  
at Wescon — August 20-23

# Transitron

electronic corporation  
wakefield, massachusetts

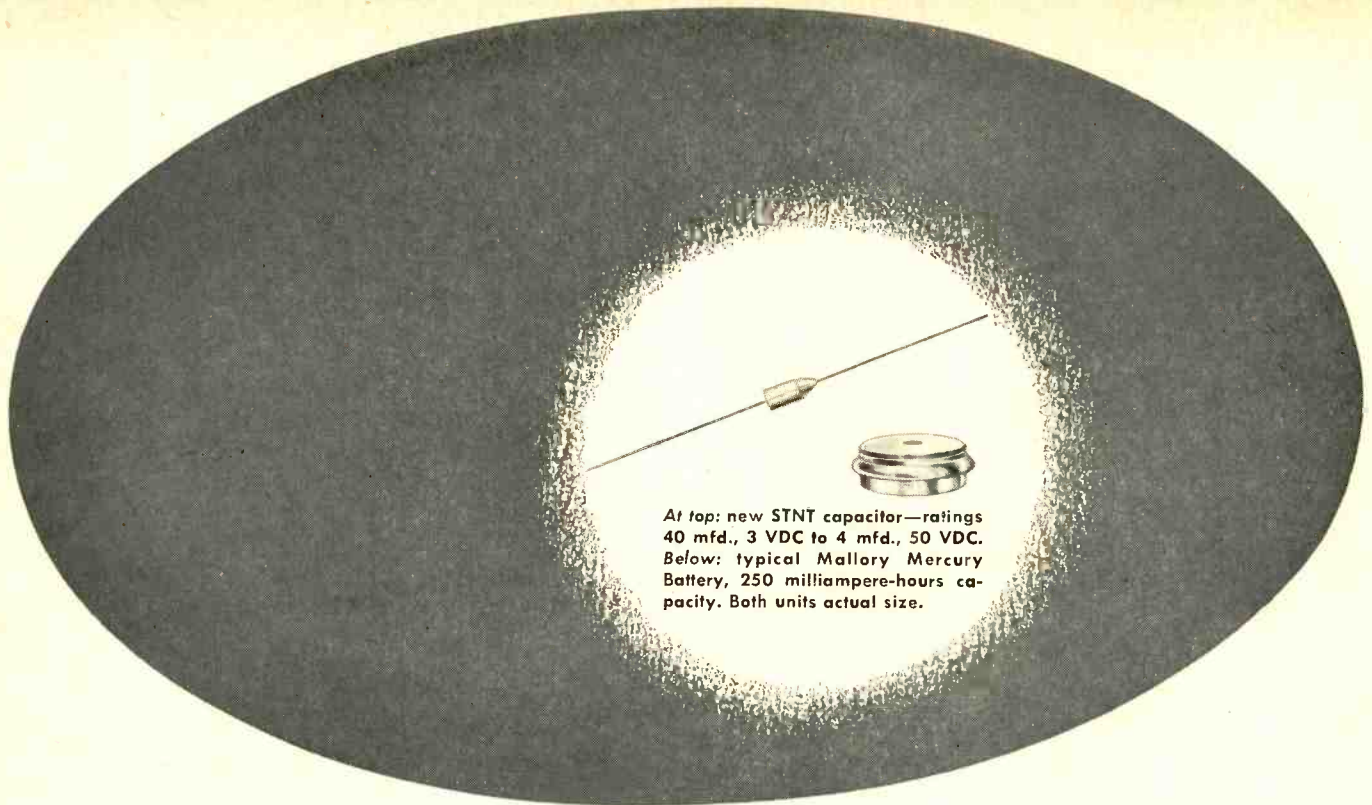

At top: new STNT capacitor—ratings 40 mfd., 3 VDC to 4 mfd., 50 VDC. Below: typical Mallory Mercury Battery, 250 milliampere-hours capacity. Both units actual size.

## Big Performance in Subminiature Size —for your Transistor Circuits

The new transistorized products that you are designing can be engineered to even smaller size, and to even higher standards of performance, by using Mallory subminiature batteries and capacitors.

**Mercury Batteries**, pioneered and developed by Mallory are outstanding for high milliampere-hour capacity in extremely compact size. The unique combination of the electrochemical cell system and structure used in Mallory Mercury Batteries gives a constant energy discharge that offers the ideal power source for transistors. They last for several years on the shelf, and need no recuperative periods between use. They withstand extremes of temperature and humidity far beyond conventional batteries.

**Mallory Subminiature Capacitors** cover a complete

range of sizes and characteristics to match your applications. Newest and smallest is the STNT—only 0.145" in diameter and 0.250" long; available in ratings from 40 mfd., 3 VDC to 4 mfd., 50 VDC. Other models include: ultra-miniature TAW tantalum capacitors in 1 to 6 mfd. ratings; TAP tantalum capacitors for  $-55$  to  $+80^{\circ}$  C, rated 2 mfd./90 VDC to 30 mfd./6 VDC; TNT tantalum capacitors with double the capacity of STNT, in slightly larger case size; and type TT miniature aluminum electrolytics.

Mallory application engineers can give you valuable assistance not only in selecting the subminiature components for your application, but also in coordinating circuit designs for peak over-all performance. Write today for technical data and for a consultation.

**Expect more . . . get more from**



Serving Industry with These Products:

**Electromechanical**—Resistors • Switches • Tuning Devices • Vibrators  
**Electrochemical**—Capacitors • Mercury and Zinc-Carbon Batteries  
**Metallurgical**—Contacts • Special Metals • Welding Materials

Parts distributors in all major cities stock Mallory standard components for your convenience.

**See us at Wescon . . . The Mallory Booth is 1312**





READY  
GET SET...  
(3, 2, 1...)

**ANDREW**

**HELIX®**

*A truly flexible  
air-dielectric cable*

At the zero second everything must function without failure. ANDREW HELIX cable is used in postassembly and preflight checkouts of missile radio frequency systems. The cable forms a closed circuit over which interrogation and response signals are transmitted between checkout equipment and airborne radio frequency packages. The HELIX cable runs from a mobile trailer to connecting points on the missile.

The ruggedness of HELIX makes it well suited to this challenging task, where its low VSWR, low RF leakage and low attenuation give accurate measurement of systems performance. Flexibility permits the cable to be taken down, recoiled and subsequently reused many times.

If you require similar characteristics in a cable, consider the special advantages of HELIX.

HELIX is normally supplied as an assembly, complete with end fittings factory attached, reducing installation labor and improving quality.

Complete uniformity throughout its entire length gives HELIX superior electrical characteristics.

HELIX is always less difficult, less costly to install, easier to handle.

HELIX is available in 7/8" size (Type H0) and 1 5/8" size (Type H1).

WRITE FOR FREE SAMPLE LENGTH

ANTENNAS • ANTENNA SYSTEMS  
TRANSMISSION LINES

**Andrew**  
CORPORATION

363 EAST 75th STREET • CHICAGO 19

OFFICES: NEW YORK • BOSTON • LOS ANGELES • TORONTO

# 15 g's VIBRATION



## NO PROBLEM with Bell's NEW 400 mc Receiver

**M**odular packaging techniques enable Bell Aircraft Corporation's new 400 megacycle receiver to meet the exacting requirement of 15 g's vibration from 5 to 2000 cycles, solid mounting.

Now thoroughly proven and in production, this receiver is available immediately for any application where demodulated control signals are needed for the activation of command systems requiring a high signal-to-noise ratio, high sensitivity and stability, and a wide audio bandwidth with low harmonic and phase distortion. It is equally at home in guided missiles — as a range safety instrument — or as a ground monitor receiver.

The new 400 mc receiver is only one of many examples of the ability of Bell Aircraft's new *Avionics Division* to design, develop and produce avionic systems, units and components for any needs, however complex. If you have design or production problems in this field, write, wire or phone: Sales Manager, Avionics Division, BELL AIRCRAFT CORP., Post Office Box One, Buffalo 5, New York.



THIS NEW BOOK telling of many new and unusual developments in the field of Avionics is yours for the asking. Send request on your letterhead to: Sales Manager, Avionics Division, BELL AIRCRAFT CORP., Post Office Box One, Buffalo 5, N. Y.

### ELECTRICAL SPECIFICATIONS

**TYPE:** FM 300 KC Deviation  
**TUNING RANGE:** 406 to 420 megacycles  
Plug-in assemblies to extend range to 500 mcs available  
**OSCILLATOR:** Crystal controlled  
**SENSITIVITY:** 5 microvolts or better for 10 db quieting  
**INPUT IMPEDANCE:** 50 ohms  
**BANDWIDTH:** 1.15 mcs  $\pm$  .1 at 3 db  
**IMAGE AND SPURIOUS RESPONSE:** Better than 60 db  
**OUTPUT:**  $\pm$  0.5 db 40 cps to 40 kc 3 db at 100 kc  
3.5 volts RMS 500 ohms closed circuit  
**SQUELCH:** Adjustable squelch relay from 10 to 100 microvolts input  
**POWER INPUT:** Less than 50 watts. Power supplies available for 115V - 400 cps or 28VDC

### MECHANICAL SPECIFICATIONS

**DIMENSION:** 3.6 x 5.5 x 15.25 inches.  
**VOLUME:** 300 cubic inches  
**WEIGHT:** 10 pounds  
**MOUNTING:** Solid — 9 mounting screws  
**OPERATING ENVIRONMENTS:** 15 g's  
5 to 2000 cycles -55° to +72°C

See this new receiver  
at Bell Aircraft's Avionics Division  
Display at WESCON Booth 1209-1210



Avionics Division  
BUFFALO, N. Y.



# Uniformly **DEPENDABLE!**



## Dependably **UNIFORM!**

Because Stackpole *Ceramag* ferromagnetic cores are so dependably uniform, they help assure maximum operating uniformity for the equipment in which they are used. *Ceramag* samples match your specifications . . . and each production unit matches the sample.

Write for Bulletin RC-9A giving details on latest available grades.



# **STACKPOLE** *Ceramag*<sup>®</sup> **FERROMAGNETIC CORES**

ELECTRONIC COMPONENTS DIV.

STACKPOLE CARBON COMPANY • ST. MARYS, PA.

When you think of

# SILVER

Think of Handy & Harman

Because . . .

- Handy & Harman is the leading manufacturer of silver and silver alloys for industry.
- During 90 years in precious metals, Handy & Harman has helped develop many of the uses of silver by industry.
- Experience and research have established Handy & Harman as the Number 1 authority on silver.

This experience and knowledge is at your call. Whatever your silver requirements, Handy & Harman is anxious to be of service.

Here are some of the forms Handy & Harman manufactures:

- Fine Silver (wire, strip and foil)
- Silver anodes and grain for plating
- Silver contact alloys
- Silver powders
- Silver flakes and paints
- Silver brazing alloys
- Silver electronic solders
- Silver sintered metals
- Solder-flushed silver alloys
- Silver chloride and oxide
- Coin Silver (wire and strip)
- Silver Bi-metals

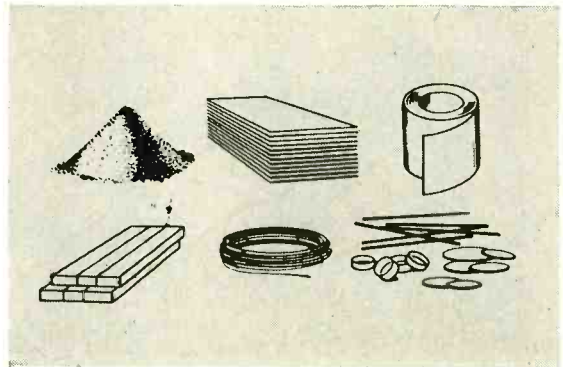

**For your information file**

We have four Technical Bulletins giving engineering data on the properties and forms of Handy & Harman Silver Alloys. We would like you to have any or all of those that particularly interest you. Your request, by number, will receive prompt attention.

Fine Silver . . . . .	Bulletin A-1
Silver-Copper Alloys . . . . .	Bulletin A-2
Silver-Magnesium-Nickel . . . . .	Bulletin A-3
Silver Conductive Coatings . . . . .	Bulletin A-4

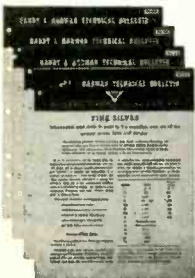

Your NO. **1** Source of Supply and Authority on Silver Alloys



**HANDY & HARMAN**

General Offices: 82 Fulton St., New York 38, N. Y.

OFFICES and PLANTS • BRIDGEPORT, CONN.  
 PROVIDENCE, R. I. • CHICAGO, ILL. • CLEVELAND,  
 OHIO • DETROIT, MICH. • LOS ANGELES, CALIF.  
 TORONTO, CANADA • MONTREAL, CANADA



# Visual and Electronic error-free decade counter



BEAM  
SWITCHING  
TUBE



NIXIE  
ALL  
ELECTRONIC  
READOUT  
TUBE

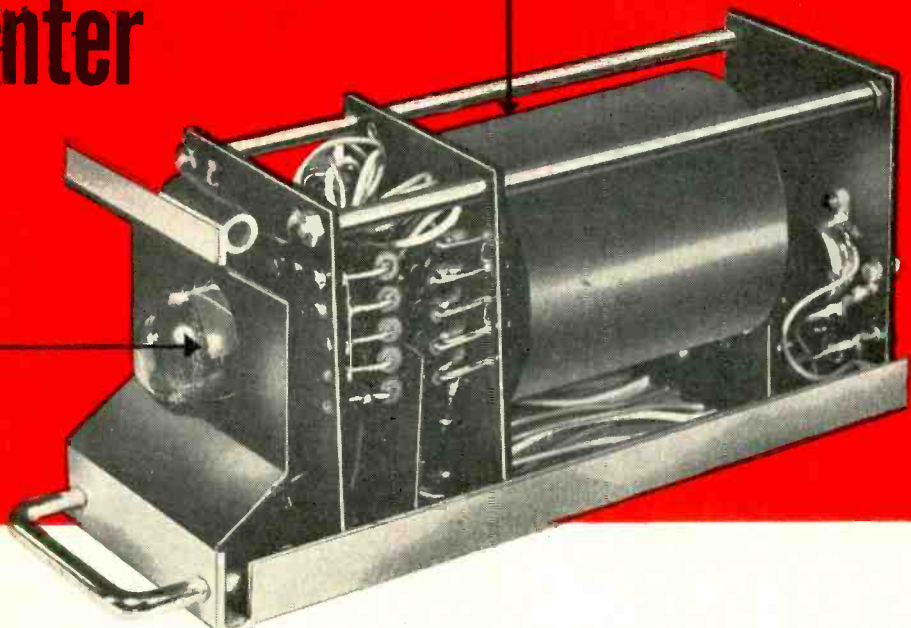

## MOST EASILY READ UNIT *Ever Made*

NOTE THESE OUTSTANDING FEATURES

- NIXIE READOUT IN-LINE FIGURES VISIBLE 30-40 FT.
- RELIABILITY OF BEAM SWITCHING TUBE
- OPERATION WITH FULL TOLERANCE VARIATION OF ALL COMPONENTS.
- SMALLEST PANEL HEIGHT (3-1/16")
- MINIMUM HEATER WATTAGE
- PLUG-IN DESIGN
- PROVISION FOR MECHANICAL OR ELECTRONIC ZERO-SET
- UNITS CASCADED DIRECTLY

AVAILABLE IN THE FOLLOWING MODELS

DC-101	10 KC
DC-102	100 KC
DC-103	1 MC

Burroughs new Decade Counter with an all-electronic numerical readout is available. The unit consisting of the **Burroughs Beam Switching Tube** and **NIXIE Indicator Tube** is the first Decade Counter which displays numerical information that is directly controlled by a single counter tube.

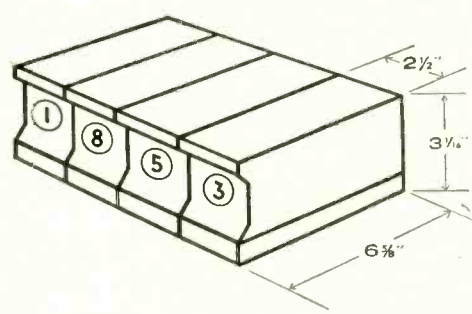

# Electronic Tube Division



BURROUGHS CORPORATION

Plainfield, New Jersey

# reduce costs

with

**SOUTHCO**

## CAPTIVE PANEL SCREWS *from stock*

Here's a low-cost retractable screw fastener to save you assembly time and to eliminate the frequent need for costly special design fasteners. Unmatched for fast, economical use by assemblers of electronic units and other paneled cabinets.

"Floating" screw insures easy alignment no matter how many screws are engaged in a single panel. No special skills or tools needed; installation fast and simple.

3 head sizes and 3 standard thread sizes available. On special order, slotted heads, stainless steel screws, and extra long screws.

Write for complete information. Southco Division, South Chester Corporation, 233 Industrial Highway, Lester, Pa.

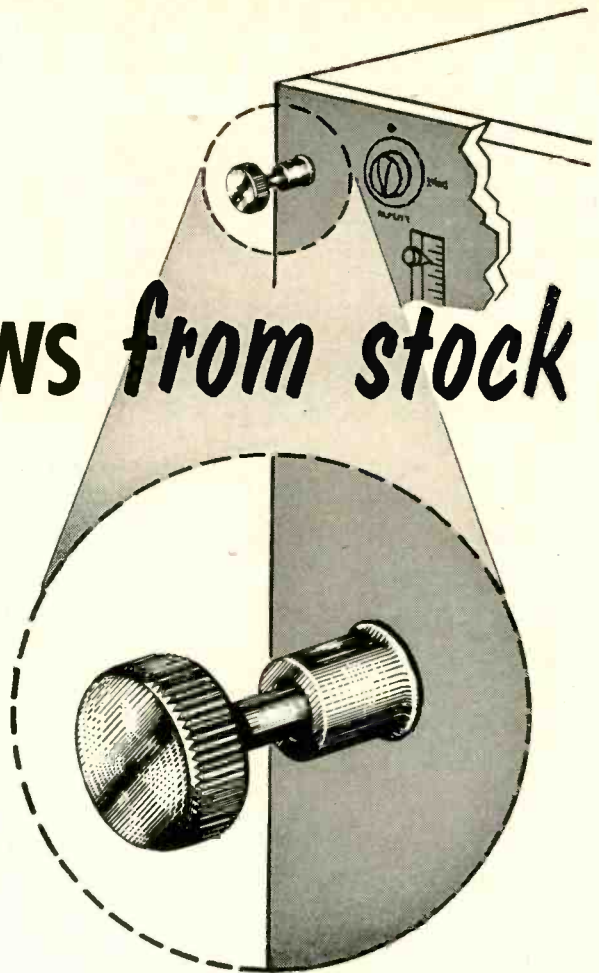

### 3 SIMPLE COMPONENTS

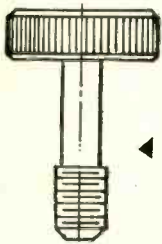

← SCREW

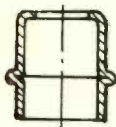

← STAND-OFF



← RETAINING RING

#### EASILY INSTALLED

Stand-off is flanged into panel. Screw is inserted into over-size hole in stand-off and locked in place by retaining ring, which is passed over threads to seat behind last thread.

### A SIZE FOR EVERY NEED

#### LARGE HEAD ( $\frac{3}{4}$ " diameter)

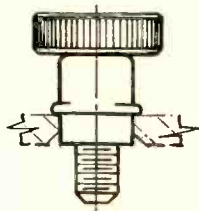

$\frac{1}{4}$ "-20 thread

#### MEDIUM HEAD ( $\frac{1}{2}$ " diameter)

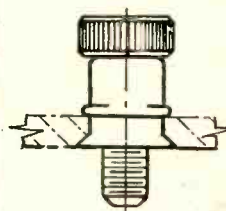

$\frac{1}{4}$ "-20 and  
12-24 thread

#### SMALL HEAD ( $\frac{1}{8}$ " diameter)

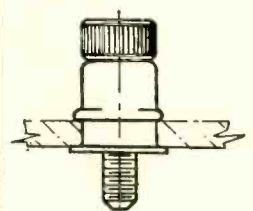

10-24 thread

Screw and stand-off are brass, nickel plated. Retaining ring is durable vinyl plastic.

Choice of stand-offs for each screw size to accommodate panel thicknesses from  $\frac{1}{16}$ " to  $\frac{1}{4}$ ".

**SOUTHCO**

**FASTENERS**

©1956

**LION**

SOUTH CHESTER CORPORATION • LESTER, PENNSYLVANIA



# TRANSISTORIZED

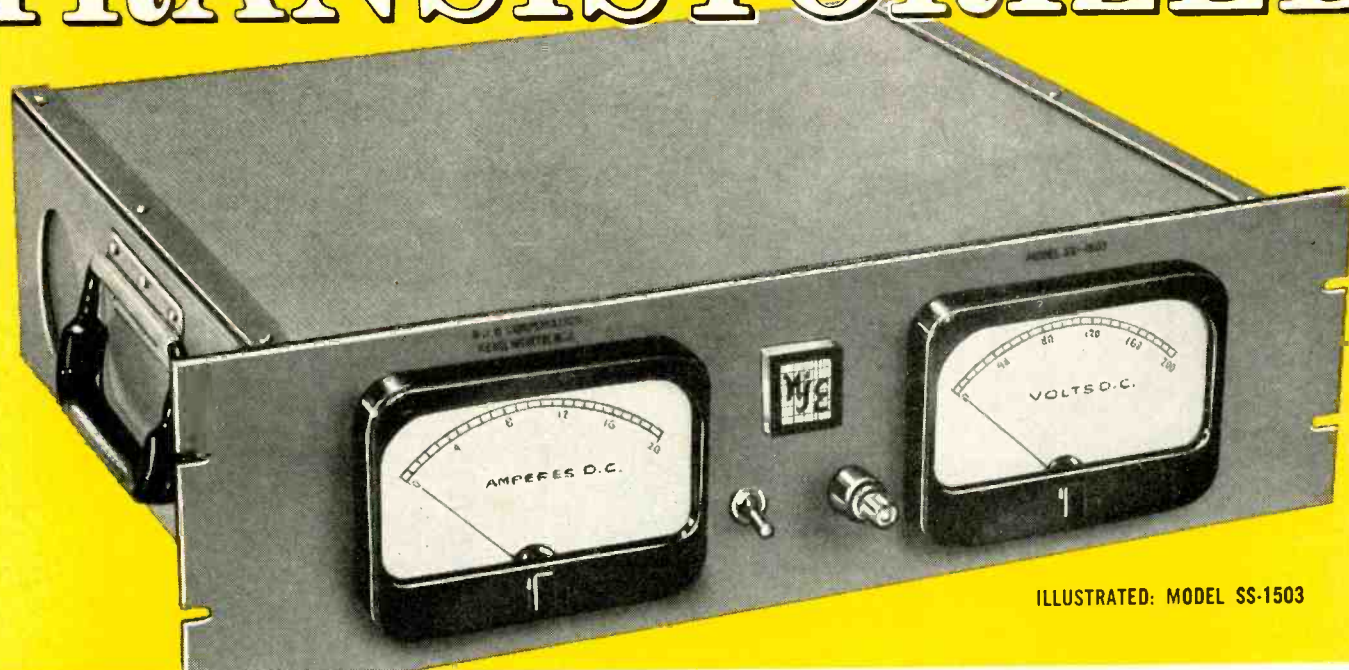

ILLUSTRATED: MODEL SS-1503

**Input:** 105-125V, 60-500 cps, approximately 3A.

**Output:** 100-150V, 0-1.5A.

**Ripple:** ONE MILLIVOLT RMS.

**Regulation:** Line, 0.1%, 105-125V. Load, 0.1%, NL-FL.

**Transient Response:** ZERO-LAGGED for  $\pm 10\%$  line transient or  $\pm 25\%$  load transient.

**Output Impedance:** 0.06 ohms at dc. Less than 0.5 ohms, DC-500KC.

**Meters:** 0-150 volts, 0-2 amperes,  $4\frac{1}{2}$ " rectangular, 2%.

**Size:** Standard 19" panel,  $5\frac{1}{4}$ " high,  $14\frac{3}{4}$ " deep behind panel.

**Duty:** Continuous, between  $-20^{\circ}\text{F}$  and  $110^{\circ}\text{F}$ , 100% humidity, 0 to 10,000 feet.

**Polarity:** Reversible and floatable to 500V peak from chassis ground.

**Price:** \$465. f.o.b. Kenilworth, New Jersey. Generous quantity discounts. Delivery 15 days.



## SOLID STATE POWER SUPPLIES

# have Everything!

**ULTRA COMPACT**—More power supply per inch of panel height than ever before!

**COOL**—Throws less heat into the cabinet than any other type of supply . . . 1/10th the heat generated by vacuum-tube equivalents.

**FULLY TRANSISTORIZED**—Semi-conductor rectifiers, zener-diode reference standards, transistor series regulators, transistor loop amplifiers.

**HIGH STABILITY**—Improved high-gain balanced PNP amplifier—prestabilized zener reference.

**LOWER PRICE**—As much as 30% less than inferior vacuum-tube equipment.

**TEN MODELS**—Covering 0-300V at 0-1.5 amperes for every plate, bias, and clamp application.

*Write for our Solid State Catalog.*

**NJE** corporation  
*Electronic Development & Manufacturing*

345 CARNEGIE AVENUE, KENILWORTH, NEW JERSEY

Competent Engineering Representation Everywhere

N J E L E A D S T H E P O W E R S U P P L Y F I E L D

# Quick facts on the



401

## GENERAL PURPOSE LOW-FREQUENCY OSCILLOSCOPE

The new standard of the industry... It features: DC to 100 kc bandwidth; identical X- and Y-amplifiers; 100 mv (10mv/cm) full scale sensitivity on both axes; precision calibrated sweeps from 50 msec/cm to 4 usec/cm (125, msec/in to 10 usec/in); and continuous sweep expansion up to 3 times without disturbing sweep controls. Beam gate circuitry is included for complete retrace blanking. Hard-tube circuitry for generating recurrent and driven sweeps is also incorporated. Cathode-ray tube is a 5ADP- operated at 3000 volts potential.

Price \$462<sup>00</sup>



403

## EXTREMELY HIGH SENSITIVITY FROM D-C TO 300 KC

The most sensitive oscilloscope commercially available. Has a sensitivity range of 5 mv to 500 volts full scale, continuously variable, and a bandwidth of D-C to 300 kc. Maximum drift is 1 mv per hour after warmup. The high gain D-C amplifier permits measurements from most transducers without pre-amplification. 19 calibrated linear sweeps from 0.5 sec/cm to 0.5 usec/cm are available. Any 10 cm portion of 50 cm of expanded screen is positionable on screen. Y-amplifier is accurate to 5% overall.

Price \$580<sup>00</sup>



404

## HIGH REPETITION RATE PULSE GENERATOR

Hard tube circuitry (no hydrogen thyratrons) eliminates all bumps and squiggles — assuring hair-line firing of sharp-edged pulses. Provides repetition rates to 100,000 pps, or single pulses by manual triggering. Jitter between trigger and pulse is less than 0.002 usec maximum. Pulse rise and fall time is 0.018 usec maximum, and pulse width is continuously adjustable between 0.05 and 100 usec. 59.5 db of attenuation in 0.5 db steps is available with no pulse degradation. Maximum pulse output is 50 V into 50 ohms; trigger output is 25 volts. Internal delay from 2 usec before trigger to 8 usec after.

Price \$675<sup>00</sup>

**Write for complete details...**



# DU MONT<sup>®</sup>



# series



405

## MULTI-PURPOSE VACUUM-TUBE VOLTMETER

High precision measurements on both A-C and D-C are now possible with a single meter. May be used for off ground operation — measures up to 1000 volts D-C off ground. 121 megohm D-C input resistance. Useful for A-C voltage measurements from 20 cps to 700 megacycles. Measurements on either A-C or D-C can be made down to 0.1 volt, full scale. Meter includes seven continuously calibrated resistance ranges, an illuminated mirror-backed scale, dual input, and has very low drift (plus/minus 3 mv max. on any range). Amplifier output available with gain over 60 db. D-C and filament supplies are regulated.

Price **\$265<sup>00</sup>**



407

## TRANSISTORIZED PRE-AMPLIFIERS

The perfect accessory for any scope. It provides common mode rejection up to 10<sup>6</sup>:1. Differential gain of 10. Frequency response is 0.15 cps to 10 kc. Completely self-contained and extremely compact — powered by battery with life of 1000 hours. Negligible internal noise and drift is featured. Circuitry is temperature compensated.

Price **\$125<sup>00</sup>**

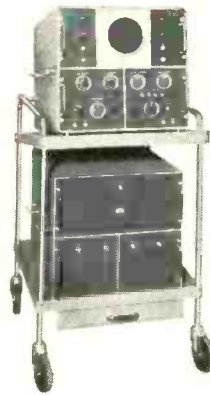

410

## HIGH FREQUENCY OSCILLOSCOPE

For complete quantitative investigations from D-C to beyond 50 megacycles. Building block design permits selection or physical interchange of desired units. High sweep rate — up to 250 kc. Y-amplifier rise time is less than 7 millimicroseconds. Calibrated sweeps from 0.02 sec/cm to 0.01 usec/cm are provided. Sensitivity is from 0.2 to 200 volts full scale. A-C or D-C sync is available with level selection. Type K-1546 cathode-ray tube is operated at 24,000 volts. Unit sections ready for immediate insertion in standard relay racks.

Price **\$3,500<sup>00</sup>**



## SEE ALL



## SERIES AT WESCON

See them, operate them — find out for yourself why the 400 Series is the biggest news in the instrument industry... They'll all be there in booths 1810 & 1811 at the WESCON Show.

Note:  
All prices for 60-cycle areas.

Technical Sales Department • ALLEN B. DU MONT LABORATORIES, INC. • CLIFTON, N. J.

# AiResearch servo- controller for a pilotless guidance system

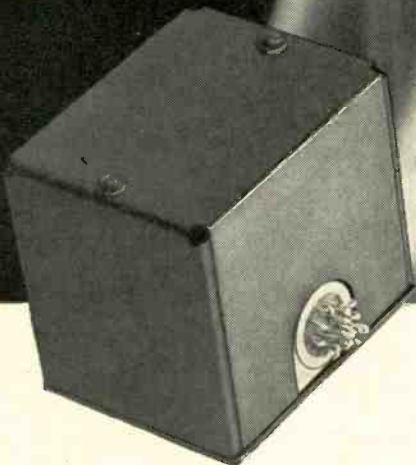
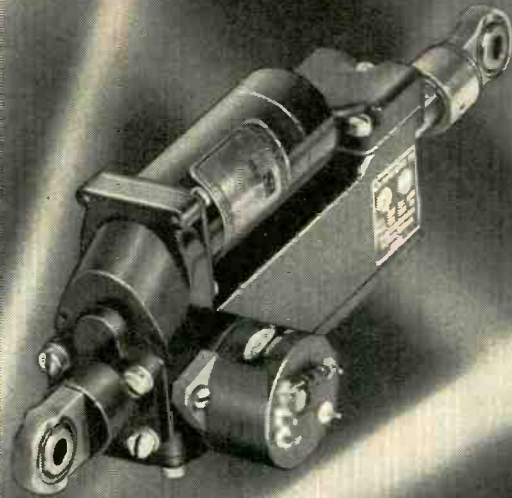

Simple servo-amplifier... actuator system achieves maximum speed of response with high stability

Because most missiles and drones are self-destructive, it is important that the components in their guidance systems be both highly accurate and dependable and be producible in quantity at low cost. The AiResearch servo-controller meets the above requirements.

It operates as follows: an AiResearch servo-amplifier weighing less than .7 of a pound amplifies electric signals from an inertial guidance source and

converts them to command signals. These in turn are transmitted to an AiResearch electrically-powered light weight linear actuator which adjusts control surfaces of missile or drone to maintain a predetermined course.

The servo-controller can operate from either a DC or AC power supply. It can also be designed to take signals from celestial, telemetering or pre-programming sources to maintain or

readjust the course of its pilotless air vehicle. It is another example of the AiResearch Manufacturing Division's capability in the missile field.

Inquiries are invited regarding missile components and sub-systems relating to air data, heat transfer, electro-mechanical, auxiliary power, valves, controls, and instruments.

*Outstanding opportunities for qualified engineers.*

**THE GARRETT CORPORATION**  
AiResearch Manufacturing Divisions

Los Angeles 45, California... Phoenix, Arizona

Designers and manufacturers of aircraft and missile systems and components: REFRIGERATION SYSTEMS • PNEUMATIC VALVES AND CONTROLS • TEMPERATURE CONTROLS  
CABIN AIR COMPRESSORS • TURBINE MOTORS • GAS TURBINE ENGINES • CABIN PRESSURE CONTROLS • HEAT TRANSFER EQUIPMENT • ELECTRO-MECHANICAL EQUIPMENT • ELECTRONIC COMPUTERS AND CONTROLS



See  
**Coors**  
at the

**WESCON SHOW**

*for the newest  
ideas  
in high strength  
ceramics*

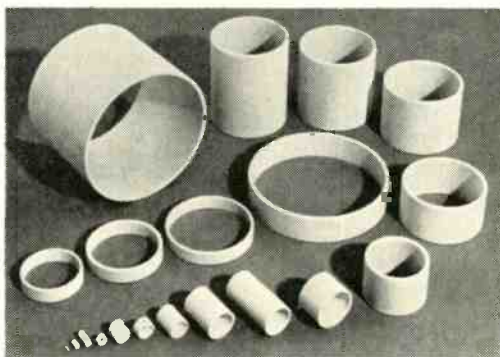

**SEE** examples of COORS high strength ceramic vacuum tube envelopes in sizes as large as 10" diameter by 10" length.

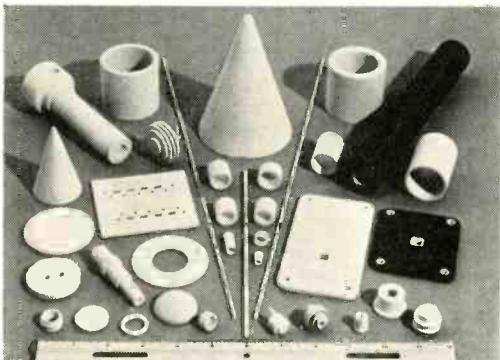

**SEE** examples of COORS high strength ceramic used in both low and high frequency circuits.



**SEE** the new line of COORS standard terminal insulators—high temperature metalized and brazed for high temperature applications.

**COORS PORCELAIN COMPANY**  
**GOLDEN, COLORADO**

*Manufacturers of High Strength Alumina Ceramics*



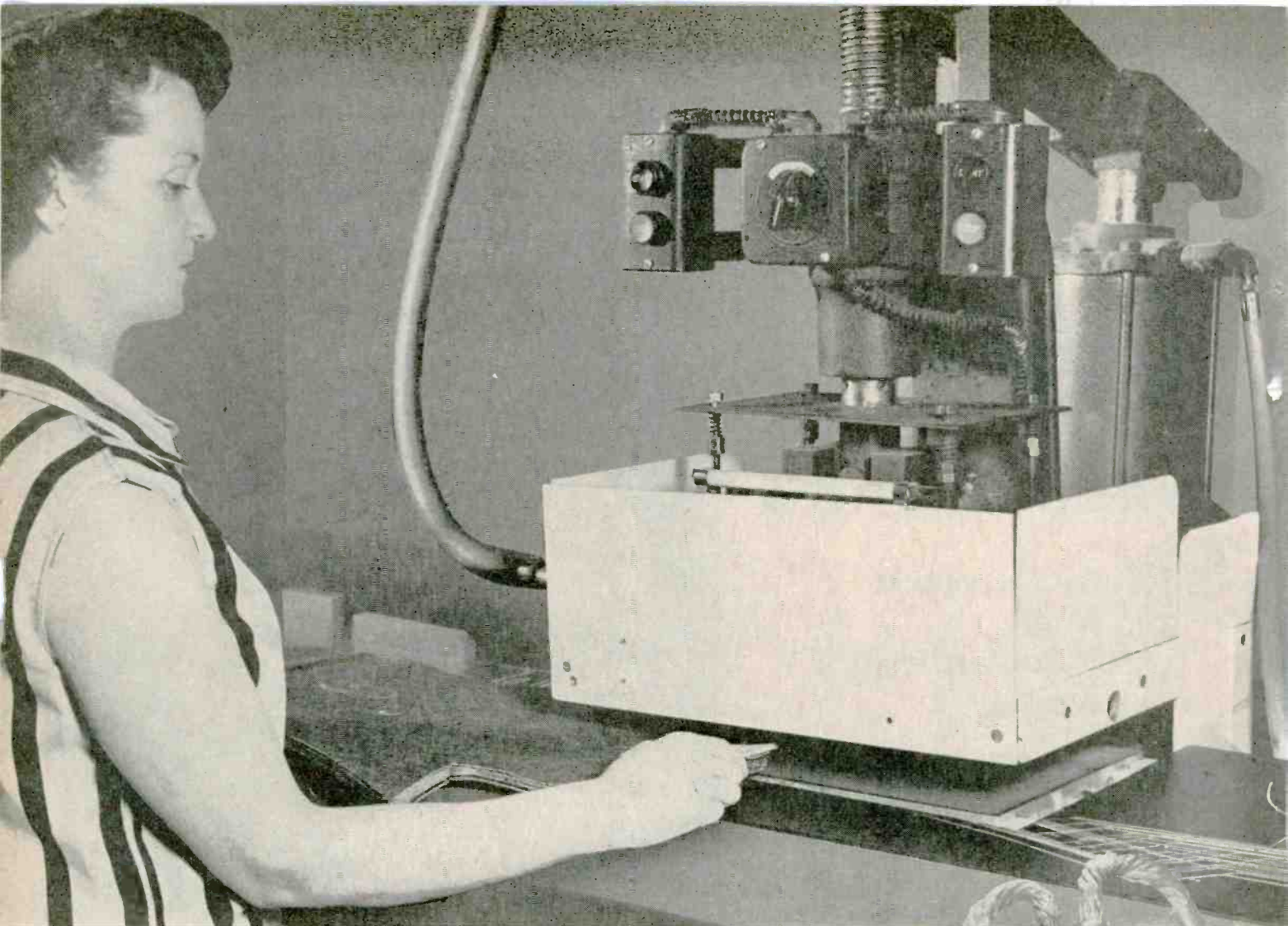

## EIMAC Powers Pants Reinforcer

10 kw dielectric heating system uses Eimac 3X2500F3

Industry has turned to the versatile electron to speed up mass production techniques. Shown above is the Radio Frequency Company 10KW patch press now in use at the Levi Strauss Company factory in Santa Cruz, California.

Used to literally "weld" strengthening rubberized patches into the knees of children's jeans, the speed and uniform heating of this modern dielectric heater does the job six times as fast as the old-fashioned all-steam press system.

A single, sturdy, long-lived Eimac 3X2500F3

power triode is used in a conventional tuned-grid, tuned-plate 27 mc circuit, that welds patches permanently at the rate of 225 dozen pairs daily. The operator reinforces six pant legs at a time, at an average time interval of 30 seconds for each operation.

Eimac has a complete line of rugged "tubes that can take it" for electronic heating in food, plastics, plywood, rubber and other industries.

See Eimac Tubes That Can Take It  
at WESCON, San Francisco Cow Palace,  
August 20-23,  
booths number 1706 and 1727-28.



**EITEL-McCULLOUGH, INC.**  
SAN BRUNO · CALIFORNIA

*Eimac First for industrial electronic heating*



### Typical operation 3X2500F3 Class C Power Amplifier or Oscillator

D-C Plate Voltage	5000 volts	D-C Grid Current	180 ma	Plate Power Input	12,500 watts
D-C Plate Current	2.08 amps	Peak R-F Grid Input Voltage	765 volts	Plate Dissipation	2,500 watts
D-C Grid Voltage	—500 volts	Driving Power (approx.)	136 watts	Plate Power Output	10,000 watts
		Grid Dissipation	46 watts		



CEC announces the new

**ALECTRA** line...

# portable test instruments

...with laboratory precision

## ALL-TRANSISTOR CIRCUITRY ON PRINTED WIRING

Now, for the first time, you can order precision instruments from a *complete, lightweight line* of miniaturized units of identical size. Salient features are battery operation, transistor circuitry, printed wiring. Rubber feet and collapsible leather handles guarantee easy, practical stacking. Also readily adaptable to standard rack mounting, these units assure instant stable operation with no warm-up time. *Contact your CEC field office, or write today for Bulletin CEC 7000-X1.*



**MODEL 10A, A-C ELECTRONIC VOLTMETER**  
Self-contained battery power. All-transistor circuitry on printed wiring. Unique sensitivity and stability are ideal for field or bench testing of modern communication and data-handling equipment. Measures voltages from 1 mv full-scale to 300 volts full-scale. Frequency range from 20 cycles to 500 kilocycles. Size 6"x8"x5 1/2"; weighs only 5 lbs. Trouble-free operation. Competitively priced.

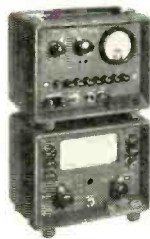

**MODEL 25A  
TEST OSCILLATOR (TELECOMMUNICATIONS)**  
8 preset frequencies (pushbutton)  
Balanced output—600 ohms impedance



**MODEL 15A  
MULTI-RANGE A-C VOLTMETER**  
Balanced input—30 cps to 300 kc  
1 mv to 300 v full-scale



**MODEL 14A, TRUE-RMS A-C VOLTMETER**  
0.5 mv full-scale  
Response: 10 cps to 500 kc



**MODEL 20A  
TEST OSCILLATOR**  
15 cps to 150 kc  
0.5-ohm output impedance



**MODEL 11A, DBM/DBA METER**  
For bridging 600-ohm circuits  
Balanced input—50 cps to 25 kc



**MODEL 21A  
TEST OSCILLATOR (PUSH-BUTTON)**  
8 preset frequencies  
15 cps to 150 kc



**MODEL 40 SERIES  
CARRIER FREQUENCY ATTENUATORS**  
0.2 db accuracy, d-c to 600 kc  
1-db steps to 82 db

# Consolidated Electrodynamics

**ALECTRA** DIVISION  325 North Altadena Drive, Pasadena 15, California

OFFICES IN PRINCIPAL CITIES THROUGHOUT THE WORLD

Now available...

# Du Pont Hyperpure Silicon in new grades!



Whether you make or use silicon devices, investigate how new grades and broader commercialization of silicon can benefit you

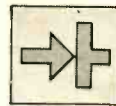

Du Pont silicon used in rectifiers, transistors and photocells can now be closely matched to device needs, because of newly established, clear-cut differences in grades. Each grade has a rated maximum content of boron, the most critical impurity. Because of this new grading, more efficient use of Du Pont Hyperpure Silicon is now possible.

**GRADE 1**—This grade, with a maximum of 3 atoms of boron to every billion atoms of silicon, has the highest quality. It is a new grade developed for such devices as power rectifiers and power transistors, permitting lower reverse currents and hence higher-rated voltages.

**GRADE 2**—meets the needs of intermediate-voltage devices, such as those used in the field of radio and television. This grade contains no more than 6 parts of boron per billion. It is useful, too, for such applications as rectifiers for variable speed motors.

**GRADE 3**—is useful in making high-current, low-voltage devices such as diodes and low-voltage transistors. It has excellent potential for use in rectifiers for alternating-current generators in automobiles. This grade contains a maximum of 11 parts per billion of boron.

**SOLAR-CELL GRADE**—is the basic material used in solar batteries for

powering telephone lines, radios and toys. Solar-grade silicon is a high-quality photoconductive material.

### Quantities to meet today's needs

If you are a manufacturer of silicon devices or are planning to manufacture semiconductors, there is sufficient production capacity for Du Pont Hyperpure Silicon to meet anticipated requirements and assure you of an uninterrupted supply. Technical information on the growing of single crystals and the measurement of their properties is available to you. Get in touch with us about your silicon problems. We will be pleased to help you.



**DU PONT HYPERPURE SILICON** is available in three polycrystalline forms—needles, dense lumps and cut rods. At the Du Pont laboratories, a single-crystal ingot, such as those shown at left, is grown from each lot of polycrystalline Hyperpure Silicon.

The specifications are based on the values determined in our laboratory from resistivity measurements of such crystals and resistivity measurements of floating zone refined bars cut from those crystals. Boron concentrations refer to those in the melt from which the characterization crystals are grown.

Part of this characterization crystal is included with each shipment of a full lot of silicon. It may be used by the manufacturer as a seed to initiate the growth of single crystals and also as a resistivity reference to check the purity of single crystals grown from the lot.

Provision of these seed crystals is part of the service rendered to crystal growers by Du Pont, the pioneer producer of semiconductor-grade silicon in commercial quantities.



### NEW BOOKLET ON DU PONT HYPERPURE SILICON

If you manufacture or use silicon devices, you'll want this new booklet which provides property data on Du Pont Hyperpure Silicon. It contains basic information on silicon and some of its many uses.

*E. I. du Pont de Nemours & Co. (Inc.), Pigments Department  
Silicon Development Group, Wilmington 98, Delaware.*

### PIGMENTS DEPARTMENT



REG. U. S. PAT. OFF.

BETTER THINGS FOR BETTER LIVING  
... THROUGH CHEMISTRY





for increased design freedom, economy and reliability

# select from the industry's widest line...

available to you on rapid delivery, in mass-production quantities, for the complete transistorization of scores of commercial and military circuits.

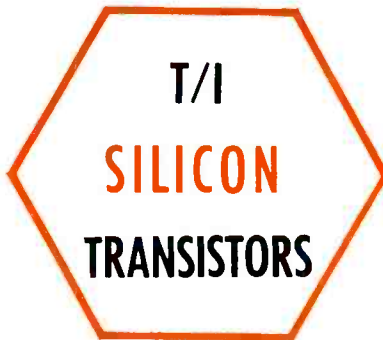

For your high temperature applications, TI silicon transistors are available in a choice of soldered cases for use in existing equipment, oval welded cases to meet U.S.N. specs, and round welded cases for new designs.

1.	2.	3.	Dissipation at 25°C W	Small Signal Current Transfer Ratio $h_{fe}$		Collector Current $I_c$ mA (max.)	DC Current Transfer Ratio $h_{FE}$		Collector Breakdown Voltage-V $V_{CBO}$ (min.)	Saturation Resistance $R_{CS}$ Ohms (max.)	Alpha Cutoff Frequency $f_{\alpha}$ mc (min.)	
				(min.)	(max.)		(min.)	(max.)				
<b>small signal</b>												
	903	2N117	0.150	9	20	25			30	45	300	
		USN2N117										2N332
		2N118										
	904	USN2N118										2N333
	904A	2N118A										2N334
	905	2N119	0.150	36	90	25			30	45	300	
		USN2N119										2N335
	910											2N336
<b>switching</b>												
		2N337	0.125			20	20	55	40	300	20	
		2N338	0.125			20	45	150	40	300	10	
<b>high frequency</b>												
		3N32	0.125			10	Power Gain: 20 db (min.) at 4.3 mc					
		3N33	0.125			10	Power Gain: 18 db (min.) at 12.5 mc					
		3N34	0.125			10	Power Gain: 16 db (min.) at 30 mc					
	925		0.125			10	Power Gain: 15 db (min.) at 12.5 mc					
	926		0.125			10	Power Gain: 14 db (min.) at 30 mc					
	3N27											
<b>medium power</b>												
	951	2N339	0.750	1	9	60			50	55	300	
	952	2N340	0.750	1	9	50			80	85	350	
	953	2N341	0.750	1	9	40			120	125	400	
	2N243	2N342	0.750	1	9	32	60			60	350	
	2N244	2N343	0.750	1	28	90	60			60	350	
<b>power</b>												
	970		8.75			140	3		120	200		
<b>high power</b>												
	2N424		37.5			2 amp	10		60	10		
	2N389		37.5			2 amp	10		60	6		

	Former Designation	Dissipation at 25°C mW	Collector Voltage-V (max.)	Collector Current mA (max.)	Beta		Conversion Gain db		IF Gain db		Audio Gain db		Power Gain db (min.)	Alpha Cutoff Frequency mc (avg.)
					(min.)	(max.)	(min.)	(max.)	(min.)	(max.)	(min.)	(max.)		
<b>VHF tetrode pnp</b>														
	3N25	501	25	-15	-2	65 (des. cen.)							10@100mc	250
<b>high frequency pnp</b>														
	2N248		30	-25	-5	20 (des. cen.)							10@18mc	50
<b>radio converter and IF</b>														
	2N253		65	12	5				28	32	at 455 kc			
	2N254		65	20	5				32	36	at 455 kc			
	2N172	830	65	16	5			22	28					
	2N145		65	20	5				30	33	at 455 kc			
	2N146		65	20	5				33	36	at 455 kc			
	2N147		65	20	5				36	39	at 455 kc			
	2N148		65	16	5				32	35	at 262.5 kc			
	2N149		65	16	5				35	38	at 262.5 kc			
	2N150		65	16	5				38	41	at 262.5 kc			
	2N148A		65	32	5				32	35	at 262.5 kc			
	2N149A		65	32	5				35	38	at 262.5 kc			
	2N150A		65	32	5				38	41	at 262.5 kc			
	2N252		30	-16	-5			30						
	2N308	375	30	-20	-5				39	42	at 455 kc			
	2N309	376	30	-20	-5				41	44	at 455 kc			
2N310	377	30	-30	-5				37			28*			
<b>audio output pnp</b>														
	2N185	252	150	-20	-150								Class A: 39	
	2N238	310	50	-20									Class B: 26	42
	2N291	357	300	-25	-200								Class A: 31	
													Class B: 22	
<b>general purpose</b>														
	2N364	200A	150	30	50	9	19							2.5
	2N365	201A	150	30	50	19	49							3
	2N366	202A	150	30	50	49								3.5
	2N367	300	150	-30	-50	9	19							0.7
	2N368	301	150	-30	-50	19	49							1
2N369	302	150	-30	-50	49								1.3	
<b>power pnp</b>														
	2N250	356	25W	-30	-3A	30	Class B Power Output: 10W					Class A 30		
	2N251	356A	25W	-60	-3A	30	Class B Power Output: 40W					Class A 30		
<b>phototransistor npn</b>														
	800		65	20	5									

\* Audio voltage gain =  $\frac{E_{out}}{E_{in}}$  in recommended circuit

VISIT OUR BOOTHS NO. 3001, 3002, 3019, 3020 AT THE 1957 WESCON SHOW







# FILTRON TRIGGER PULSE PACKAGES FOR HYDROGEN THYRATRON TUBES

Trigger pulses  
according to  
latest MIL-E-1  
spec for  
Hydrogen  
Thyratrons  
5949/1907,  
5948/1754 and 1257\*

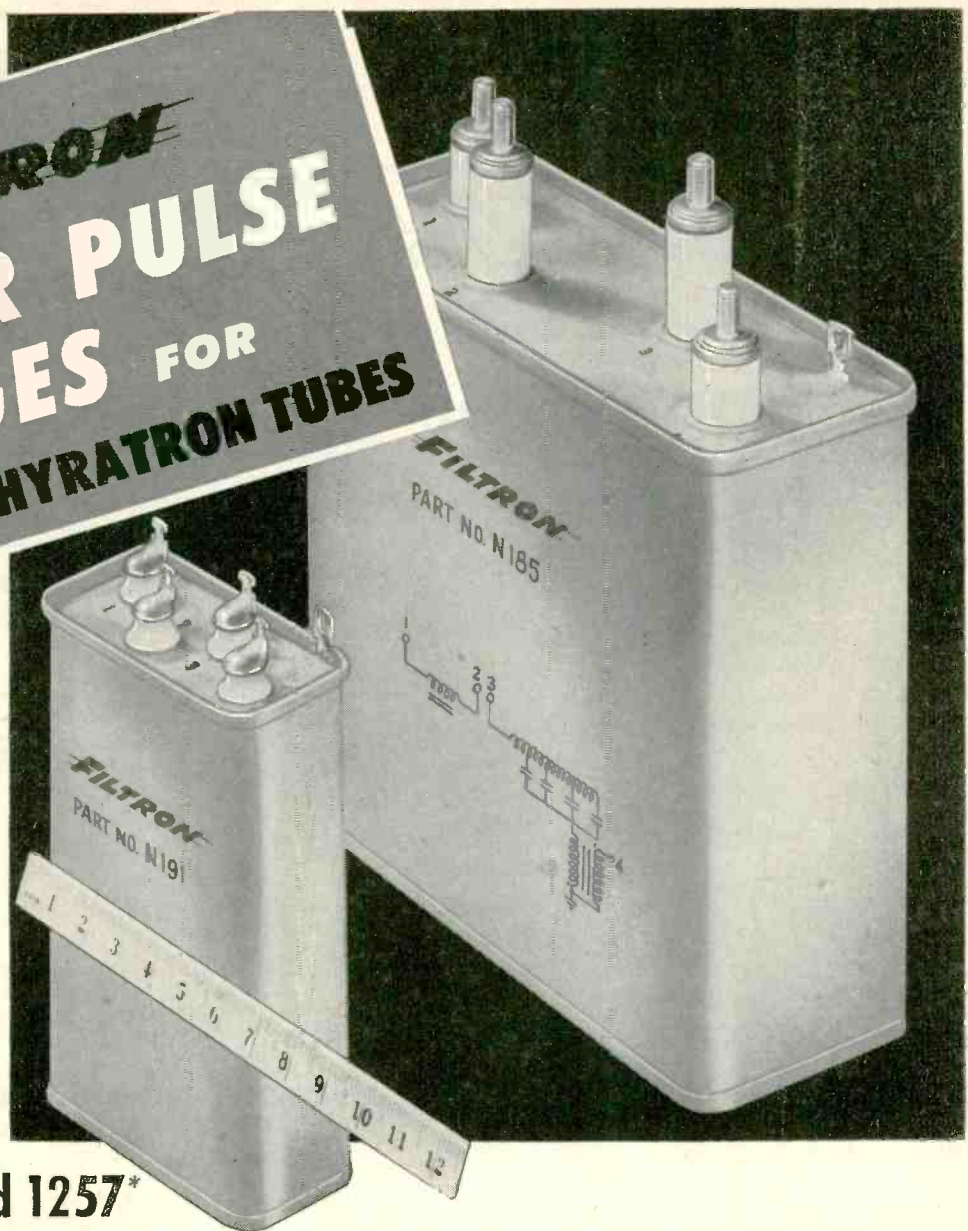

EACH PULSE PACKAGE INCLUDES CHARGING REACTOR, PULSE FORMING NETWORK AND PULSE TRANSFORMER SPECIFICALLY DESIGNED FOR THIS APPLICATION.

#### FILTRON TRIGGER PULSE PACKAGE N-191

For 5949/1907 and 5948/1754 thyratrons

Size: 1 1/8" x 2 1/2" x 4 1/4" high (4 3/4" overall)

Input: 550 VDC @ 26 MA max.

Output (thyatron grid disconnected)

Pulse Width: 2  $\mu$ sec min at 70% amplitude

Amplitude: 1000 V peak positive

Rise Time: 0.35  $\mu$ sec max. 26-70%

Impedance: 70 ohm nominal

Repetition Rate: 0-1500 pps

#### FILTRON TRIGGER PULSE PACKAGE N-185

For 1257 thyatron

Size: 2 1/4" x 5 3/4" x 5 1/2" high (7" overall)

Input: 4 KVDC @ 82 MA max.

Output: (thyatron grid disconnected)

Pulse Width: 2  $\mu$ sec min. at 70% amplitude

Amplitude: 2500V peak positive

Impedance: 15 ohm nominal

Repetition Rate: 0-1250 pps

\*There is no MIL specification for the 1257 type thyatron, but the pulse package characteristics conform to the latest extant specifications for this tube.

**FILTRON** CO., INC., FLUSHING, LONG ISLAND, NEW YORK  
PLANTS IN FLUSHING, NEW YORK, AND CULVER CITY, CALIFORNIA

RF INTERFERENCE FILTERS • FIXED CAPACITORS • PULSE NETWORKS • DELAY LINES

# New!

## Honeywell Motors



for chart drives, servos,  
balancing circuits, remote positioners

Now from Honeywell come these newly-designed synchronous and two-phase motors of highest quality. New, sectioned die cast housing . . . new wicking to prevent oil leakage . . . ball bearings to reduce friction . . . printed circuits . . . are some of their many maintenance-saving features. What's more, you can replace any part in two minutes, usually without disconnecting the leads from your installation.

Order these motors in small quantities for prototype development, or by the thousands for production runs. Models charted at right are available for fast, dependable delivery.

MINNEAPOLIS-HONEYWELL REGULATOR CO., *Industrial Division*, Wayne and Windrim Aves., Philadelphia 44, Pa.

### TWO-PHASE INDUCTION

Nominal No-Load RPM*	Gear Ratio	Intermittent Rated Load (oz.-in.)	Max. Starting Torque (oz.-in.)	Power (watts)† Loaded	Current (amps.) Loaded	Temp. Rise Deg. F
330	44:1	4	10	7.6	.11	70
148	10:1	5	20	7.0	.11	70
44	30:1	15	50	7.6	.11	70
22	60:1	30	120	7.6	.11	70

†6.0 watts in field winding, balance in amplifier winding.

### SYNCHRONOUS

RPM*	Gear Ratio	Pull-In Torque, Min. (oz.-in.)	Continuous Torque (oz.-in.)	Power (watts) Loaded	Current (amps.) Loaded	Temp. Rise Deg. F
180	10:1	12	12	19	.21	100
180	10:1	3.5	4	13	.11	65
90	20:1	14	12	11	.095	55
60	30:1	13.5	12	13	.11	65
30	60:1	27.5	12	13	.11	65

\*1/6 less at 50 cycles. Some speeds available at 25 cycles.

Weight: 29 oz. Write for Specification S900-3.

# Honeywell



*First in Controls*



Whether it's  
Standard  
or Custom  
Designs...

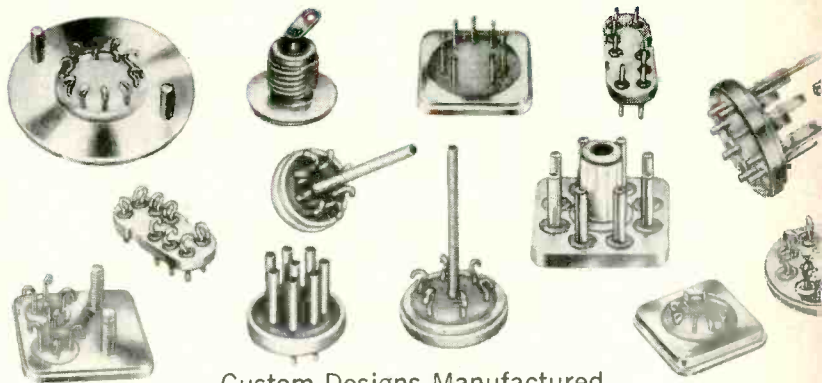

Custom Designs Manufactured  
by Electrical Industries



has the solution!



Customer-made Components Sealed  
by Electrical Industries

# GLASS-TO-METAL SEALS\*

New E-I Plant  
Speeds Production!

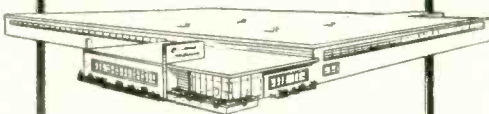

The Murray Hill facility is newly equipped throughout. Tighter quality controls, testing and inspection plus vastly increased production mean better products, faster than ever before.

\*Canadian Pat. 523,390; British Pat. 734,583; U. S. Patents Pending. All Rights Reserved.

## Here's 3-way service for designers

Electrical Industries offers complete facilities for the sealing of components in a wide range of sizes from large to sub-miniature. E-I will design and produce your complete sealed assembly, or seal components of your manufacture. The wide experience of E-I engineers is available to work out special seal requirements. For standard applications, E-I offers hundreds of economical stock terminals including single lead, multiple headers, end seals and transistor closures. Ask for a recommendation on your seal requirements or request catalog on standard E-I sealed components.



**ELECTRICAL INDUSTRIES**

MURRAY HILL, NEW JERSEY

*A Division of Philips Electronics, Inc.*

# ALLEN-BRADLEY

## QUALITY

# variable resistors

When successful circuit operation depends upon a variable resistor that is not affected by moisture, heat, cold, or age . . . the Allen-Bradley units are the answer. The solid "one piece" hot-molded structure has insulation, terminals, faceplate, and threaded bushing imbedded in the plastic body. With the resistance element as an integral part of the mold—not an added film or paint—it can be made to satisfy any resistance-rotation curve. Write for full details, today.

Sectional view showing how elements are molded in one integral unit

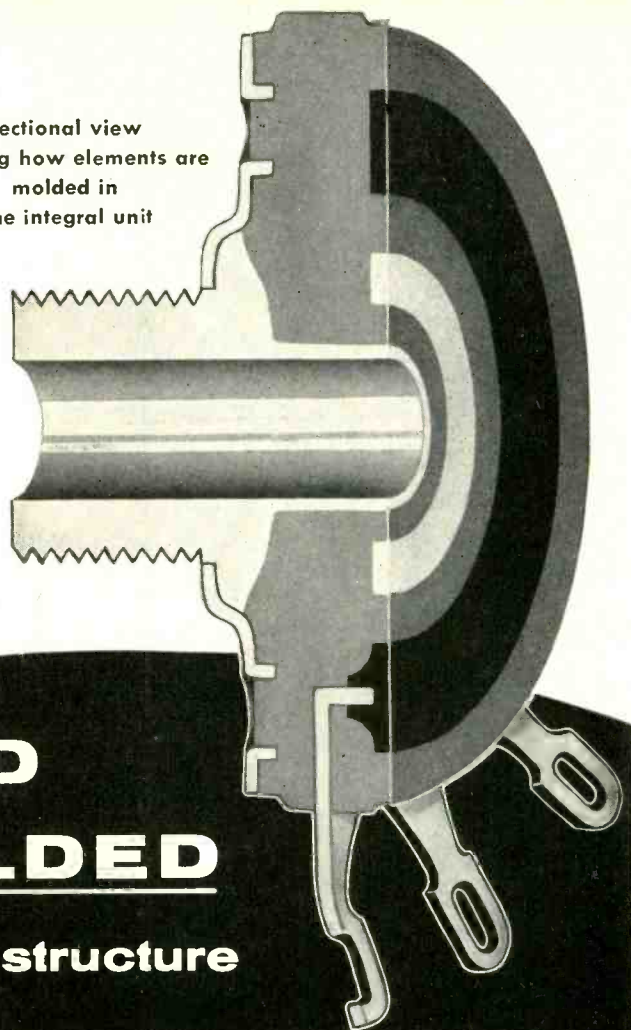

## SOLID HOT-MOLDED

in one integral structure

for long life and low noise level

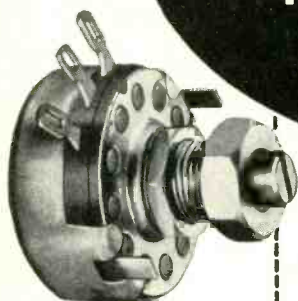

**TYPE J**—rated 2 watts at 70C ambient. Total resistance values from 50 ohms to 5 megohms. Available in single, dual, and triple units with various types of adjusting shafts, and with built-in line switch.

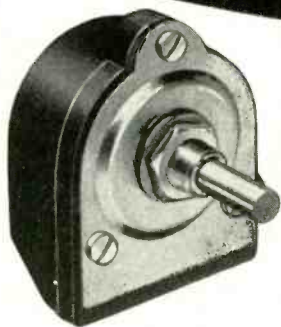

**TYPE H**—rated 5 watts at 40C ambient. Total resistance values from 50 ohms to 2.5 megohms. Good for over 100,000 cycles with no appreciable resistance change. Max. voltage 750 v, d-c.

**TYPE T**—rated 1/2 watt at 70C ambient. Plastic cover serves as actuator, making unit extremely flat. Total resistances from 100 ohms to 5 megohms.



**TYPE F**—rated 1/4 watt at 70C ambient. Diameter 1/2". Standard tapers. Slotted shaft. Designed for printed circuits.

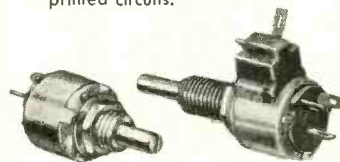

**TYPE G**—rated 1/2 watt at 70C ambient. Diameter 1/2". Plain or lock-type bushings; plain or slotted shaft. Available with line switch (right).



Allen-Bradley Co., 110 W. Greenfield Ave.  
Milwaukee 4, Wis.  
In Canada:  
Allen-Bradley Canada Ltd., Galt, Ont.

# ALLEN-BRADLEY

RADIO, ELECTRONIC, AND TELEVISION COMPONENTS





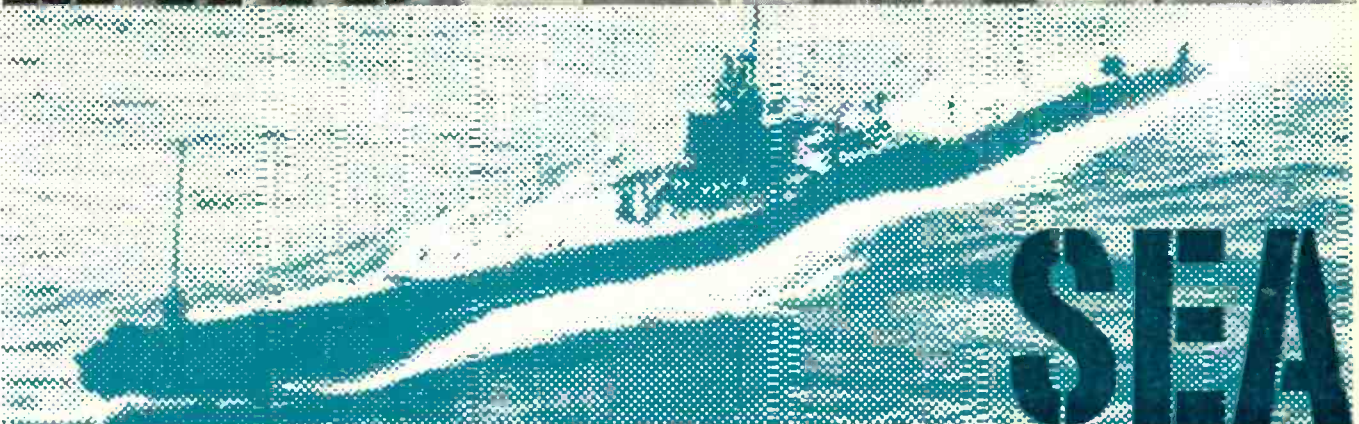
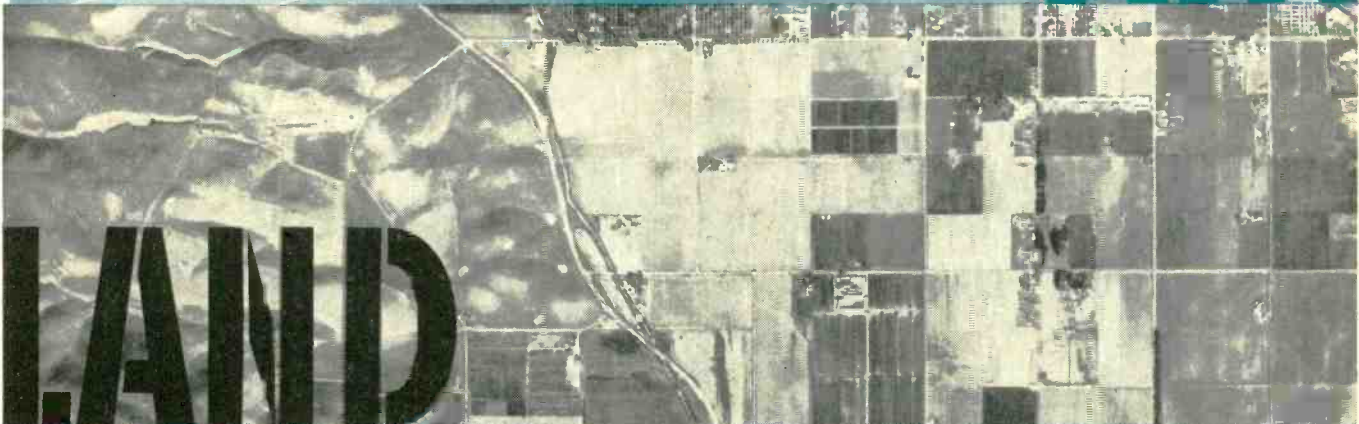
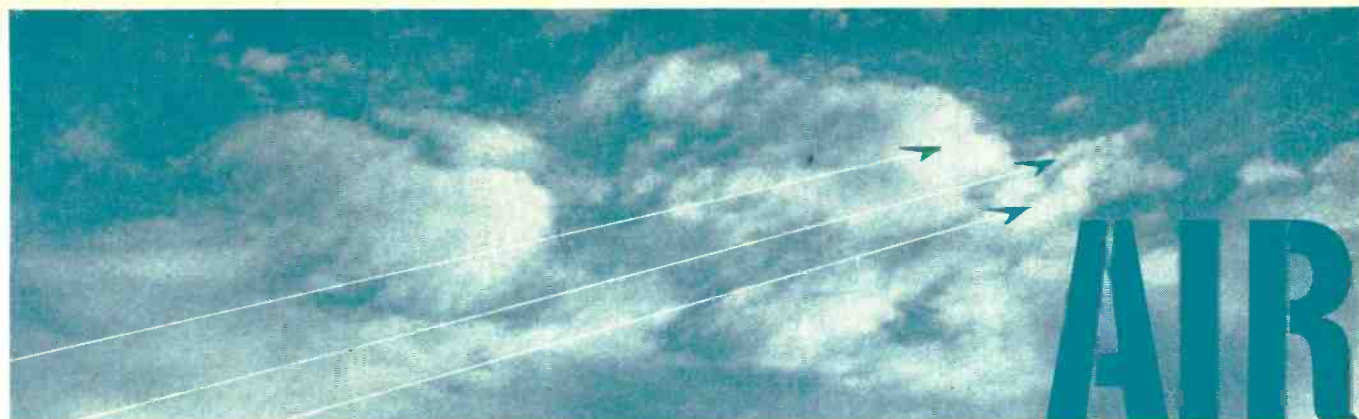

for 20 years . . . . .  
computers and controls

by **LIBRASCOPE**

**EXPERIENCE AND VERSATILITY** have earned for Librascope a position of leadership in the design, development and manufacture of computers and controls for military and industrial applications. Through extensive experience in the combination of electronic, magnetic, mechanical and optical design concepts, Librascope can offer an impressive capacity for achievement in the development of precision instrumentation. This knowledge, gained over a twenty year period, can be focused on *your* computer-control problem . . . with marked success! Your inquiry is invited.

*Engineers capable of significant contributions are invited to write Glen Seltzer, Employment Manager*



A SUBSIDIARY OF

LIBRASCOPE, INCORPORATED • 808 WESTERN AVENUE • GLENDALE, CALIFORNIA

ELECTRONICS — August 1, 1957

Circle 95 Readers Service Card

133



**EMPIRE DEVICES** proudly announce  
the opening of their  
new plant in **AMSTERDAM, New York**

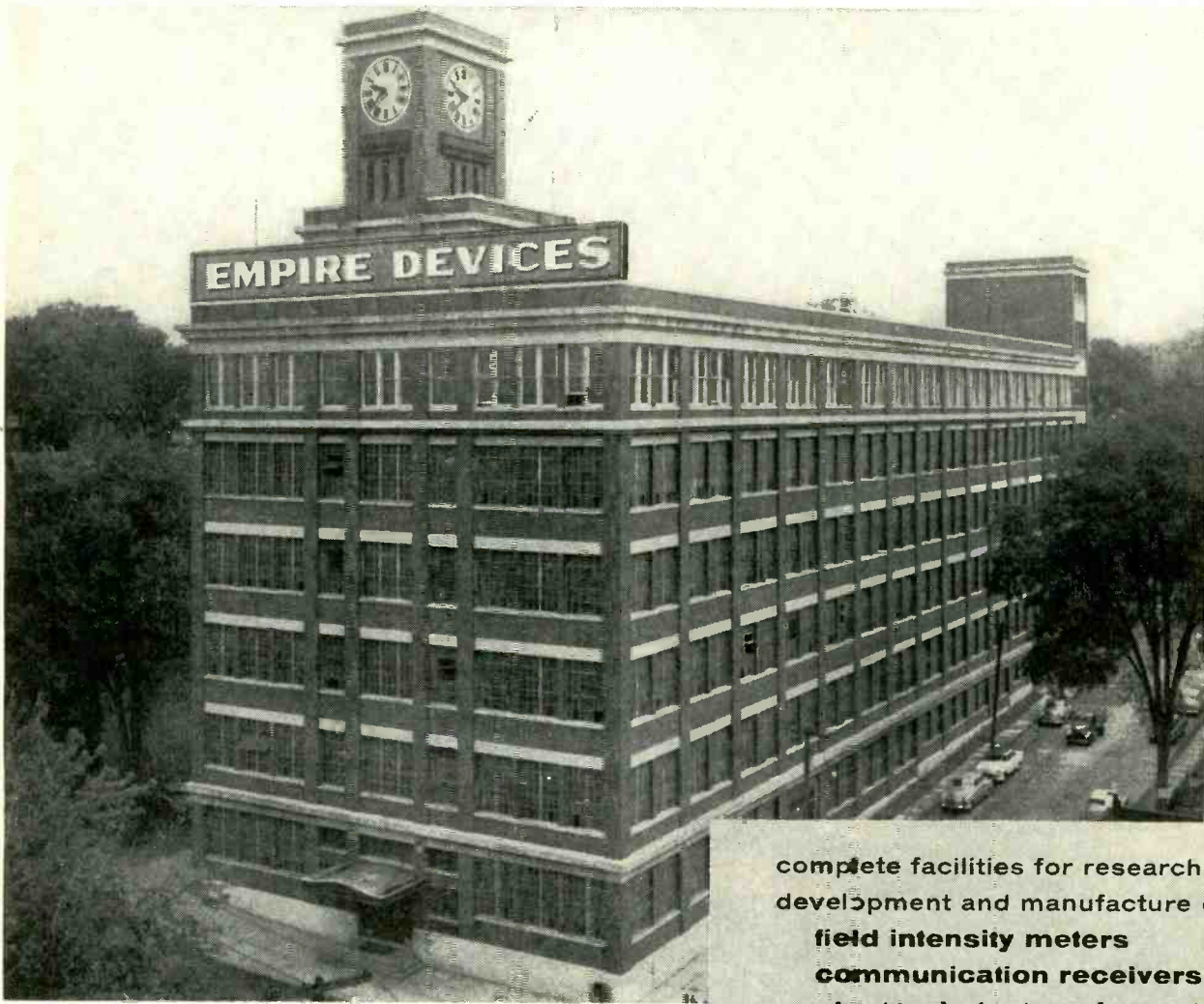

complete facilities for research,  
development and manufacture of  
**field intensity meters**  
**communication receivers**  
**electronic test equipment**  
**microwave components**  
**precision attenuators**  
**radar accessories**  
**and special power supplies**

*Send for our new complete catalog*

NEW YORK—Digby 9-1240 • SYRACUSE—GRanit 4-7409 • PHILADELPHIA—SHerwood 7-9080 • BOSTON—  
TWinbrook 4-1955 • WASHINGTON, D. C.—DEcatur 2-8000 • ORLANDO, FLA.—ORlando 3-3524 • ATLANTA  
—CEdar 7-7801 • DETROIT—BRoadway 3-2900 • CLEVELAND—EVergreen 2-4114 • PITTSBURGH  
ATlantic 1-9248 • ST. LOUIS—EVergreen 5-7728 • DAYTON—FUItan 8794 • CHICAGO—ESterbrook 9-2700  
DENVER—MAin 3-0343 • FORT WORTH—WAlnut 6-4444 • HOUSTON—MOhawk 7-6100 • ALBUQUERQUE—  
ALbuquerque 5-9632 • LOS ANGELES—REpublic 2-8103 • PALO ALTO—DAvenport 3-4455 • PORTLAND  
—CApital 7-3830 • CANADA: STITTSVILLE, ONT.—HAzeldean 56 • EXPORT: NEW YORK—MUrray Hill 2-3760

**EMPIRE DEVICES**

**PRODUCTS CORPORATION**

**AMSTERDAM, NEW YORK**

Telephone: Victor 2-8400

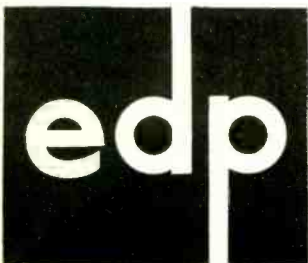



# signal generators

## 10 to 21,000 MC!

EASIER TO USE • MORE ACCURATE • MORE STABLE

### 11 TO CHOOSE FROM

With *-hp-* signal generators, frequencies are directly set and read on one dial. Output voltage is directly set and read. No calibration charts are required. Most *-hp-* generators offer internal pulse, FM or square wave modulation; some include external pulsing and FM'ing. New *-hp-* 626A (10 to 15.5 KMC) and 628A (15 to 21 KMC) offer 10 mw output, SWR 1.2.

*-hp-* signal generators outsell other signal sources by approximately 2:1. Engineers report the reasons are simpler operation, versatility, trouble-free performance, and exceptional value.

Instrument	Frequency Range	Characteristics	Price
<i>-hp-</i> 608C	10 to 480 MC	Output 0.1 $\mu$ v to 1 v into 50 ohm load. CW, pulse or AM mod. Direct calibration.	\$ 950.00
<i>-hp-</i> 608D	10 to 420 MC	Output 0.1 $\mu$ v to 0.5 v into 50 ohm load. CW, pulse or AM mod. Direct calibration and crystal calibrator check	1,050.00
<i>-hp-</i> 612A	450 to 1,230 MC	Output 0.1 $\mu$ v to 0.5 v into 50 ohm load. Pulse, CW or amplitude modulation to 5 MC Direct calibration.	1,200.00
<i>-hp-</i> 614A	800 to 2,100 MC	Output 0.1 $\mu$ v to 0.223 v into 50 ohm load. Pulse, CW or FM modulation. Direct calibration.	1,950.00
<i>-hp-</i> 616A	1,800 to 4,000 MC	Output 0.1 $\mu$ v to 0.223 v into 50 ohm load. Pulse, CW or FM modulation. Direct calibration.	1,950.00
<i>-hp-</i> 618B	3,800 to 7,600 MC	Output 0.1 $\mu$ v to 0.223 v into 50 ohm load. Pulse, CW, FM or square wave modulation. Direct calibration.	2,250.00
<i>-hp-</i> 620A	7,000 to 11,000 MC	Output 0.1 $\mu$ v to 0.223 v into 50 ohm load. Pulse, CW, FM or square wave modulation. Direct calibration.	2,250.00
<i>-hp-</i> 623B	5,925 to 6,575 MC; 6,575 to 7,175 MC; 7,175 to 7,725 MC	Output 70 $\mu$ v to 0.223 v into 50 ohm load. FM or square wave modulation. Separate power meter and wave meter section.	1,900.00
<i>-hp-</i> 624C	8,500 to 10,000 MC	Output 3.0 $\mu$ v to 0.223 v into 50 ohm load. Pulse, FM or square wave modulation. Separate power meter and wave meter section.	2,265.00
<i>-hp-</i> 626A	10,000 to 15,500 MC	Output 1 $\mu$ watt to 10 mw. Internal or external pulse, FM, or square wave modulation. Direct calibration.	3,250.00
<i>-hp-</i> 628A	15,000 to 21,000 MC	Output 1 $\mu$ watt to 10 mw. Internal or external pulse, FM, or square wave modulation. Direct calibration.	3,000.00



Your *-hp-* field engineer has complete data on all *-hp-* generators. Or, write direct.

### HEWLETT-PACKARD COMPANY

4055A PAGE MILL ROAD • PALO ALTO, CALIFORNIA, U. S. A.

CABLE "HEWPACK" • DAVENPORT 5-4451

FIELD ENGINEERS IN ALL PRINCIPAL AREAS

complete coverage, outstanding value

# Printed Circuit Controls by Mallory

Newest in the Mallory line of simplified controls for printed circuit applications—single or multiple resistance wafers applied directly on a phenolic panel which can be mounted by standard printed circuit construction techniques. Terminals are also available for solderless wire wrap assembly!

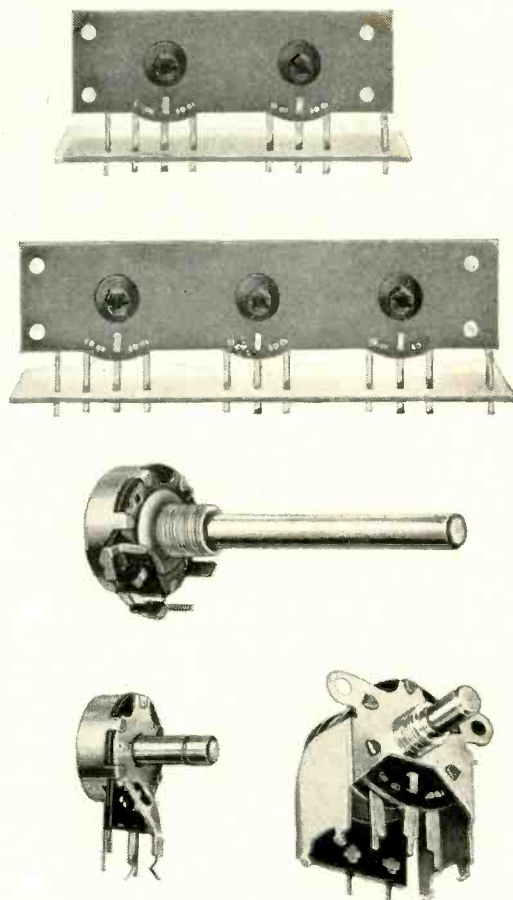

*Any way you look at it . . .*

**Mallory controls are best  
for your printed circuit design**

Here's good price and performance news for equipment manufacturers—a way to save on component cost and save on assembly cost wherever single or multiple secondary controls are used. Featuring the same high-stability resistance material as conventional Mallory controls, these elements are bonded direct to phenolic panels which can be mounted by simple printed circuit assembly methods.

Units of up to three controls can be mounted and

wired in a single operation. Resistance values up to 10 megohms per single control, and numerous combinations of controls are available.

Other Mallory controls for printed circuit equipment, using the same high-stability resistance element made by Mallory's own special process, offer the designer and manufacturer a wide choice of mounting techniques. Included are models for mounting horizontal to, or vertical to the printed circuit.

All models have precision positioned mounting lugs designed for fast, accurate assembly. All are available in a wide range of circuit values and resistance tapers to suit specific design requirements. Special low end taper for transistor volume control is now available.

*Solve a problem—and save*

**And now**—available on standard models, Mallory's new floating-ring line switch. Pull, it's on—push, it's off. Long-life contacts, reduced volume control wear, and clean, crisp switch action give your design another modern merchandisable touch.

Serving Industry with These Products:

Electromechanical — Resistors • Switches • Tuning Devices • Vibrators  
Electrochemical — Capacitors • Mercury and Zinc-Carbon Batteries  
Metallurgical — Contacts • Special Metals • Welding Materials

Parts distributors in all major cities stock Mallory standard components for your convenience.

See us at Wescon . . . The Mallory Booth is 1312

**Expect more . . . get more from**





# CROSS TALK

## ► TWO PREOCCUPATIONS . . .

In the middle and far west on a business swing, we found big manufacturers in many fields uniformly preoccupied with two major questions: what to do about the high cost of money needed for expansion, and how to stimulate consumer buying still at a high level but showing signs of wavering.

The answer to the first preoccupation we'll leave to the nation's top economists, gladly. For the answer to the second we'll go along with our own company's top economist, as we do on most things, and suggest that expenditure for research and development leading to truly new products is almost certainly the only key.

► **MICRO-MINIATURE . . .** Work on miniaturization of component parts to go with transistors has progressed to the point where, believe it or not, the transistor itself is nearly the largest component in certain assemblies.

Smaller transistors will be the next step.

► **EXHIBIT DOLLARS . . .** Trade shows within the electronics industry itself have long been considered a mixed blessing, stimulating business on the one hand and costing time and money on the other. General sentiment places high value on those that are al-

ready established, resists splinter operations.

Decision to display or not to display becomes increasingly difficult as electronics penetrates more deeply into other industries; more and more electronics booths are seen at outside shows, and some of them do pay off. These do not yet seriously clip into our own shows, but they could.

If and when they do, the following oversimplified approach might help: (1) Decide how much time and money can be spent on this type of promotion. (2) Arrange shows in order of primary audience importance. (3) Start at the top of the list with adequate space and work down. (4) When the allocation runs out, stop.

► **HOME ELECTRONICS . . .** More electronic devices for the home, and for other man-in-the-street uses, are coming, but it is hard to put the finger on the precise nature of such devices of the future.

One thing is, however, becoming apparent. The low cost of printed circuits when applied to relatively simple equipment for which there is a volume market can speed the day. Use in many electrical and electronic toys now being shown the trade for the Christmas market is a good example.

► **DEFINITION . . .** *Specification*; Collection of loopholes loosely held together by wistful verbiage.

## LOOKING AHEAD . . .

Underwater detecting techniques have been radically improved, can protect a country against submarine attack as radar protects it against air attack, will lead to commercial byproducts

*Expected leveling off of expenditures to find engineers will not indicate reduction of industry need so much as it does tightening up by government on what it is willing to allow tax-wise and otherwise for such recruiting*

Infrared is by no means alone in the passive detection field; all bodies radiate some microwave radio energy in the centimeter region under certain conditions and this energy can be separated from circuit and other noise

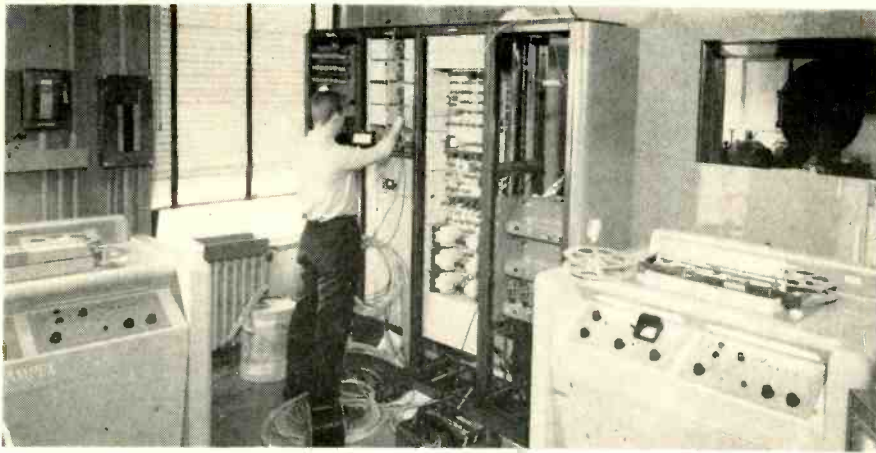

Technician wires rack equipment in ABC's Chicago video-tape recorder installation

By **ROSS H. SNYDER**

*Ampex Corporation  
Redwood City, California*

# VIDEO TAPE RECORDER

**SUMMARY** — Low tape speed and extended high-frequency response are achieved in magnetic tape recorder by revolving four recording heads transversely across tape while tape moves only fast enough to keep successive tracks from overlapping. Recorded tapes have signal-to-noise ratios of 34 to 36 db with better than 300-line resolution and high contrast ratio

**T**HREE POSSIBLE WAYS to extend the uppermost frequency response of magnetic tape recorders have been investigated. The brute force technique pulls the tape past the heads fast enough so a 4-mc signal appears on the tape as a wavelength about the same as the shortest used in audio. A second approach uses a number of channels in a time-multiplex arrangement. Both of these methods present mechanical difficulties.

This article described a third approach that revolves the head rapidly across the tape, while the tape moves only fast enough to keep successive transverse tracks from overlapping one another. This method presents a series of problems which are unique, but which are soluble in a practical, manufacturable machine.

## Video-tape Recorder

As illustrated in Fig. 1, the Ampex recorder has four heads mounted at the outer circumfer-

ence of a rotating disk with their gaps parallel to the disk axis.

Each head is spaced as nearly as possible at 90 deg from the next on the disk. With a disk diameter of about 2 in. and a rotational rate of 14,400 rpm (240 rps), the writing speed or relative head-to-tape velocity is about 1,500 ips.

The reel-to-reel tape velocity depends upon the width of the tracks which are to be laid down, one after another, transversely on the tape and upon the necessary space between them. These tracks are 10 mils wide, with an edge-to-edge separation of  $5\frac{1}{2}$  mils and a center-to-center spacing of  $15\frac{1}{2}$  mils. It is thus possible to obtain a great reduction in tape speed and to operate at the familiar 15-ips velocity. Using thin tape, 64 min of recording are obtained on a  $12\frac{1}{2}$ -in. diam reel of 2-in. wide tape.

A 120-deg arc is described during the complete sweep of a head transversely across the tape.

Since all four heads are fed the

same currents during recording, there is a duplication of information toward the end of one track on the tape and at the beginning of the succeeding one. Advantage is taken of this duplication in the switching system used to deliver continuous transient-free signals during replay.

With four heads performing 960 sweeps transverse to the tape each second or each 15 in. of tape, one frame occupies  $\frac{1}{2}$  in. of tape longitudinally and the 525 horizontal lines which make up one full tv frame are recorded on 32 successive sweeps or tracks on the tape. Each track carries 16 or 17 horizontal lines of television information.

## Three Tracks

The recorded tape has three separate, but synchronized magnetic tracks as shown in Fig. 2. The first (Fig. 2A) is the series of transverse video tracks; the second (Fig. 2B) is the sound track that accompanies the picture, which is im-





Playback of first regularly scheduled broadcast of CBS using video-type recording

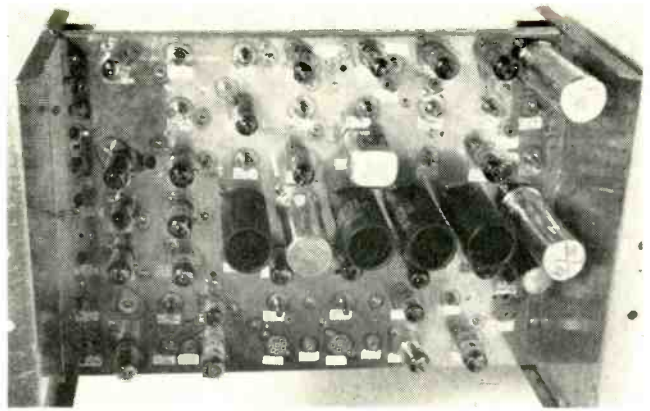

Rack-mounted video processing amplifier corrects deformation of demodulated signal during playback

# USES REVOLVING HEADS

pressed at the top of the tape; the third (Fig. 2C) is a signal that comprises a record of the alternating currents which fed the rotating disk motor during that recording.

During recording the sound track is wiped clean by the preceding erase head, for maximum signal-to-noise ratio.

Erasure has proved to be unnecessary on the control track. Even after erasure of the top 100 mils of the tape (for the sound track) and the destruction of the lower 100 mils of the recording by the control-track recording head, more than 90 deg of arc are still

recorded on each transverse track. The overlap of information is approximately two tv picture lines, or around 130  $\mu$ sec. During replay this allows a generous time interval during which electronic switching from head-to-head can take place.

### Tape Transport

The transport mechanism used is similar to that found in many professional magnetic audio recorders. As illustrated in Fig. 3, the tape is supplied from a reel on the left; it is stabilized in its motion by passing around an idler whose

motion is dominated by a heavy flywheel. It passes by the rotating video head assembly then goes on to a stationary pair of heads on one stack.

Of this stack, the upper one is an erase head which clears a 100-mil strip at the upper edge of the tape. The lower head records the control track in a similar strip along the bottom edge of the tape, without erasure. The tape then moves to a second stationary head stack which contains only the combination audio track record-replay head.

The tape next passes between a

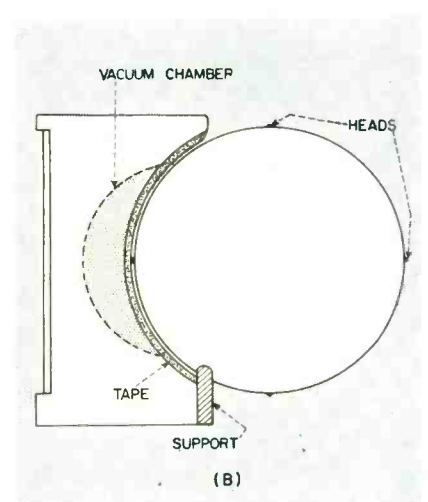
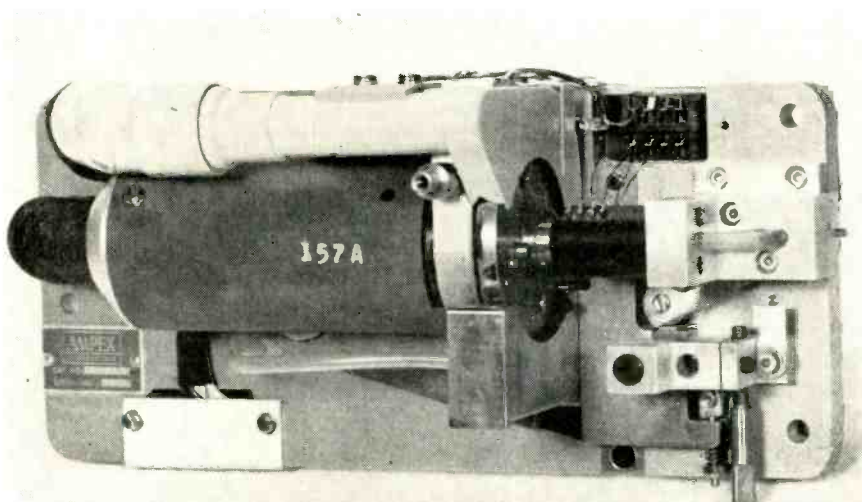

FIG. 1—Head subassembly (left) includes rotary heads, motor, commutator and vacuum guide chamber (right) to align tape

drive capstan and its pressure idler, around a takeup idler and on to a tape takeup reel at the right. The erase, audio and control track magnetic heads are stationary.

Guiding of the tape past the rotating disk is accurately, yet delicately controlled by the concave guide, shown in Fig. 1, which is used to cup the tape around the disk. The relation of tape to rotating heads must necessarily be intimate and good head contact at nearly constant pressure is required. This is accomplished by maintaining the fit of the concave guide within small tolerances to the exact path of the rotating heads and through the use of vacuum applied from the guide side of the tape.

### System Operation

The recording system is shown in block form in Fig. 4.

During both recording and replay, an intimate relation must exist between the rotation of the revolving heads and that of the capstan. This process begins at the time the signal is recorded.

While recording, the 60-cps power-line frequency is first applied to a frequency multiplier, which produces a 240-cps signal. This signal drives a three-phase power amplifier during the original recording which in turn supplies 240-cps power to the synchronous motor which drives the rotating disk.

A portion of the revolving mechanism is coated half black and half white. A light source is focused on this revolving black and white disk and reflected into a photo cell to produce a 240-cps square-wave output. This is passed through a frequency divider, coming out at 60 cycles. The signal is then passed through a filter, whose output is a clean 60-cps sine wave, which in turn is fed to a power amplifier, whose output drives the capstan motor.

The whole chain is electrically analogous to a mechanical gear train, coupling the rotation of the capstan firmly to the rotation of the head disk. Neither the head disk motor nor the capstan motor are driven directly by the 60-cps power line frequency, although the power which is supplied to the disk-driv-

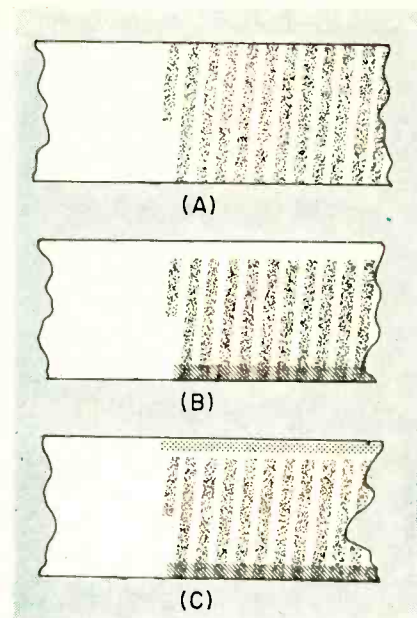

FIG. 2—Signal pattern after passing video head drum (A) paired audio-erase and control-track record heads (B) and audio-record head (C)

ing motor is directly derived from the incoming 60-cps signal.

The power supplied to the capstan is generated from the actual motion of the revolving heads, enslaving the capstan to the head disk. Thus, during the recording process, the tape is moved precisely 62.5 mils longitudinally during each complete revolution of the head disk. During this period, four lateral tracks are recorded, one for each head, each track being separated from the next by a center-to-center space of  $15\frac{1}{2}$  mils.

### Control Track

During this process, the 240-cps output of the photocell is also fed, through a bandpass filter and a series of amplifiers, to the control track head, which records the signal longitudinally on the control track at the bottom of the tape (Fig. 2B). This control track becomes the magnetic equivalent of the sprocket-holes of a sprocketed film machine. Since the 240-cps signal is derived directly from the revolving heads, the signal on the control track bears a direct relation to the spacing of the lateral tracks on the tape and this information is available as a reference to control the relative positions of the head disk and capstan shaft during replay.

When the recorded video tape is to be played back, power line frequency is again multiplied to 240 cps, amplified and fed to the head disk motor, driving it at a rate which is at least approximately correct, for the purpose of tracing the previously recorded magnetic tracks. Again, the photocell produces a signal corresponding to the revolutions of the disk, this signal, once more being fed through a 240-cps bandpass filter and then, not to the control track recording head, but instead as one of two 240-cps signals to a phase comparator in the capstan servo amplifier chassis.

The second of these two 240-cps signals is that derived from the recorded control track, which is simultaneously amplified and fed to the phase comparator. The resultant signal is a function of the phase difference between the two signals. This is applied to a low-pass filter and then to the grid of a reactance tube which is one of the frequency-determining elements of a conventional Wien-bridge oscillator.

The oscillator functions nominally at 60 cps, but is slightly modified, up or down, by the correction-signal from the phase comparator. This signal is then fed to the power amplifier which drives the capstan in the same relation to the rotating disk, within narrow limits, as it did during the recording process.

Once the disk is adjusted on center to the tracks at the beginning of replay, the servo system holds the relation constant and the revolving heads indefinitely trace accurately the recorded video tracks.

The output of the photocell can also be used to determine in advance, the approximate moment during playback when it will be

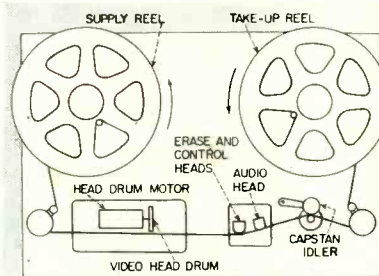

FIG. 3—Tape transport mechanism



necessary to switch from one playback head to the next.

### Editing and Splicing

There is a means of identifying that line on the tape which represents a vertical synchronizing pulse. The tape is wiped with a harmless solution that renders the magnetic recording visible. Since the vertical pulses have a characteristic and recognizable appearance, they may be located with precision. In equipment of more recent development they are used to identify the line along which the tape may be cut and spliced to another tape similarly cut.

### Modulation System

It was necessary in the development of the recorder to seek a means of recording and reproducing the range from d-c to 4 mc or more and not just the upper end of that spectrum. A modulation system came naturally to mind, a f-m system being immediately appealing and ultimately adopted, in an unusual form.

Classically, it is assumed that the highest modulating frequency used in an f-m transmission system will not exceed one-tenth the carrier frequency and that deviation will be large compared with maximum modulating frequency. This implies a carrier of 40 mc, so the use of f-m would have to be abandoned, if these conditions were to be observed.

Recording the 40-mc carrier frequency requires either a large increase in head-to-tape velocity, or a large reduction in the shortest wavelength handled or both. It seemed as if a low-frequency carrier might do. Since it was desired that the range of modulating frequencies be large, compared with the total transmissible bandpass, it was evident that it was also desirable to use an f-m system in which the frequency of deviation was small with relation to the frequency of modulation. Thus, both classical assumptions in f-m transmission were to be violated.

### Deviation Ratio

When the ratio of deviation to maximum modulating frequency is small, one pair of the sidebands is

attenuated. When the ratio of deviation to modulating frequency is 0.1, the second pair is only 0.1 percent of the unmodulated amplitude of the carrier; where this ratio is 0.5, the second pair is still only 3 percent of the unmodulated amplitude of the carrier, while the first pair has increased to 24 percent of the unmodulated carrier amplitude. It can be seen that an unbalanced sideband condition is developed as

desirable phase shift at the carrier frequency. With the lopsided f-m system, however, intelligence is preserved in the series of instantaneous frequencies which are created by the two side bands simultaneously. Since it is in the deviation that the intelligence lies, both its upper and lower excursions are meaningful.

In the case of the video-tape recorder, when the carrier is 5 mc,

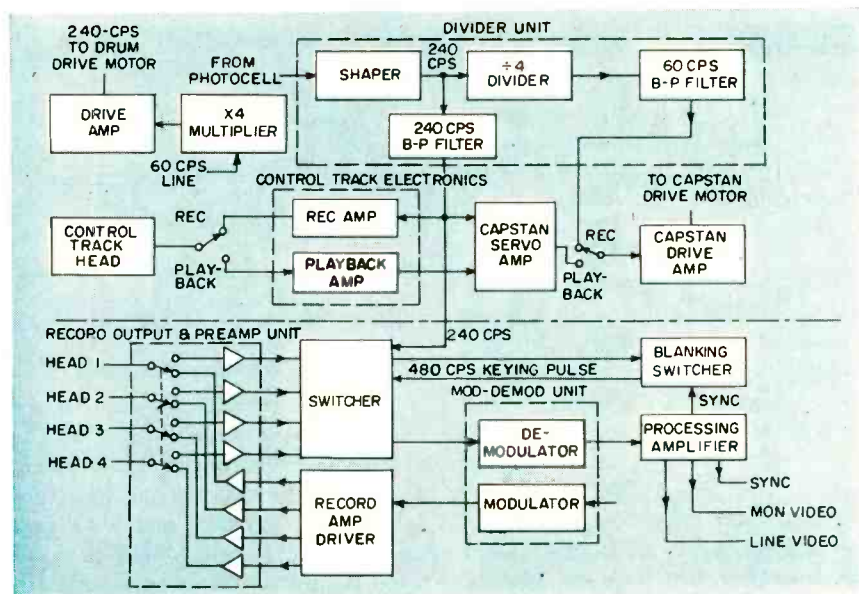

FIG. 4—System block diagram is divided into control system (top) and video (bottom)

the ratio of deviation to modulating frequency is decreased.

The exact solution to the dominant equation for the case where the ratio of deviation to modulating frequency is less than one-half is in the literature.<sup>1</sup> When this solution is applied to a series of sidebands under the conditions obtaining in the video-tape recorder, where carrier frequency equals 5 mc and deviation frequency is 1 mc or less, the unbalance of sidebands becomes quite great. These are no longer the relatively simple upper and lower sideband relations of the classical f-m system, but a new species of transmission system which might be called semi-single-sideband f-m transmission or just lopsided f-m.

In single sideband transmission of a-m signals, it is only necessary to handle enough of the vestigial sideband to insure that the filter employed does not introduce un-

maximum modulating frequency is 4.5 mc and deviation is held to 500 kc; the head-tape system must efficiently pass frequencies from 5 mc less 4.5 mc or 500 kc, up to 5 mc plus the deviation frequency or 5.5 mc.

This configuration of carrier, modulating frequency and deviation can encompass the television spectrum within the recordable bandpass of the magnetic recording system required. It is a comparatively simple matter to preserve frequency relations approaching d-c in an f-m system. At a later stage of development it may be preferable in handling the lowest frequencies to use d-c restoration techniques in the interest of simplified video amplifier circuitry.

### Signal-to-Noise-Ratio

In f-m, when the ratio of deviation to modulating frequency is large, the bulk of the transmitted

energy is in the sidebands and the noise rejection capability of the system is greatly superior to that of a-m systems. As this ratio is decreased the advantage decreases and finally disappears entirely when the f-m sideband energy is less than that which is obtained in 100-percent amplitude-modulation.

In the video-tape recording system, the deviation is 1 mc or less, giving a ratio of 0.25 or less. This results in a wide-band signal-to-noise ratio which is less than that which would be obtained with an a-m system. It was found that by holding within the tape velocity figures which were the aim, a signal-to-noise ratio well in excess of 30 db was attained over the 4-mc bandwidth.

### Distortion

The classical assumption that carrier frequency in an f-m system should be ten times the highest modulating frequency or more, was made to avoid the distortion which the higher modulation frequencies must suffer as they approach the carrier frequency. The effect of distortion of video frequencies in the band above 1 mc in the video-tape recorder is a certain amount of zig-zagging of closely spaced vertical lines.

Not only is this effect evident only on such visual material, but the effect of the blurring is greatly reduced by the nature of human vision. When images thus distorted are viewed by the eye, which integrates its experience over a substantial period of time, the result is entirely acceptable, even for images representing a horizontal resolu-

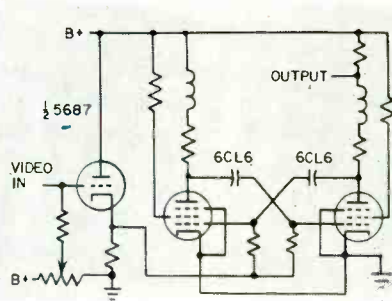

FIG. 5 Basic modulator used for recording

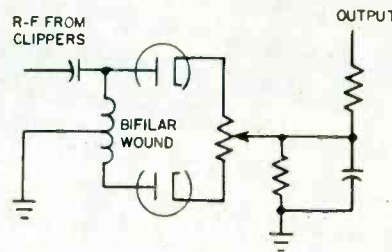

FIG 6—Basic demodulator for playback

tion of 300 lines or better.

### Modulator-Demodulator

The circuitry employed in the modulator and demodulator of the video-tape recorder is lacking in novelty. Where deviation does not exceed a megacycle, and with carriers which do not exceed perhaps 6 mc, a multivibrator type of oscillator whose frequency is controlled by direct application of video to its control grids is entirely satisfactory and simple to maintain.

As shown in Fig. 5, two 6CL6 tubes are connected as a multivibrator, with special attention to switching time; the grids of the 6CL6 tubes are driven by one section of a 5687. The multivibrator output is amplified through conventional wideband video amplifiers

and then applied in parallel to the two 815 tubes which drive the heads. Each section of the 815's drives a single head continuously during recording.

During replay, the output of each head is fed to its own preamplifier; the four channels feeding into a switcher. From the switcher a single channel of f-m r-f is fed to limiters. The last of these feeds into a bifilar coil, shown in Fig. 6, with a grounded center-tap. This coil resonates outside the system bandpass and the slope of the resulting response curve forms an f-m to a-m translator.

The resulting a-m is rectified through full-wave diodes, which feed a variable resistor acting as a balance control for the carrier. A low-pass filter, next in the chain, further reduces the level of carrier in the output.

Good linearity is readily achieved, so that grey-scale transfer is substantially undistorted.

### Playback Switching

During replay, it is necessary to derive the amplified output signal from one head at a time, switching from one preamplifier to the next at a moment in the transmission when minimum disturbance will be introduced into the reproduced picture and later to demodulate the amplified r-f output of the playback heads. The electronic switching arrangement shown in Fig. 7 was developed for this purpose.

A network of coincidence gates is employed with a get-ready signal sent to each gating tube in turn from the 240-cps photocell source; a go signal is delivered with pre-

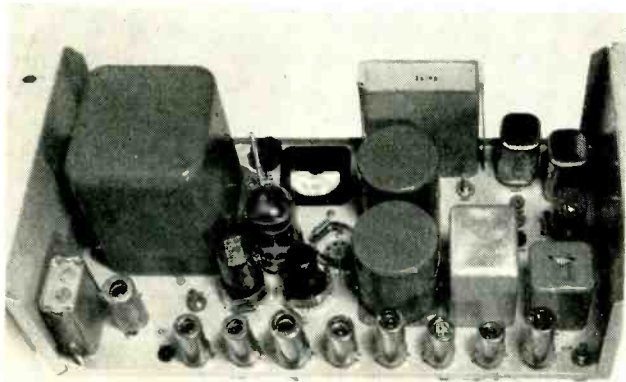

Rack-mounted capstan-drive servo control chassis supplies 240-cps driving signal to capstan

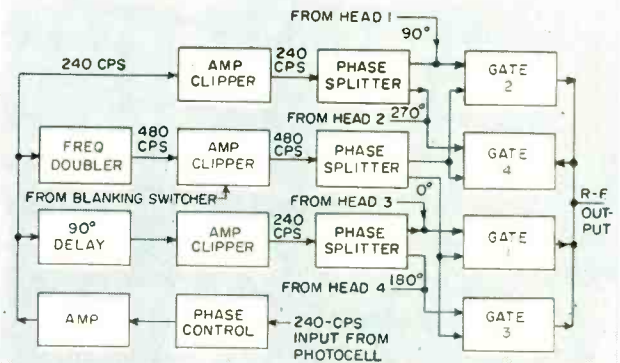

FIG. 7—During playback, electronic switcher derives output from one head at a time



cision to each gating tube from the television signal itself. Switching occurs only on the back porch of a horizontal pulse. Therefore it does not appear in the reproduced picture, even as a transient.

The 6BN6 gating tubes pass the r-f signal to their plate circuits only when each of two grids are raised to a predetermined level of bias. Thus the coincidence of two positive bias signals is used to trigger each of the four gates, consecutively.

The photocell output is delivered to the sequential switcher, as well as to the servo amplifier control system. This 240-cps signal, whose phase is directly related to the instantaneous position of the rotating head disk, is fed through a vernier phasing control to a 90-deg lag network that controls two related channels in conjunction with other signals. The same signal is continuously fed to a frequency doubler and an in-phase network.

The in-phase 240-cps signal is clipped and fed to a phase splitter, which produces two signals, one in phase and one 180-deg out of a phase. These two signals are applied to the gating tubes, the in-phase signal to one of the grids of gate 1, the opposite phase to one of the grids of gate 3. These are the same grids to which the amplified r-f from heads one and three are fed.

The 240-cps signal, which is fed through a 90-deg lag network, is similarly clipped, fed to a phase splitter, and applied to the control grids of gates two and four. In the same way, these gates receive the amplified r-f output of heads two and four at intervals of 90 and 270 deg.

### Gate Keying

To cause these gates to pass r-f at the desired times, appropriate positive swings of a 480-cps square wave are applied to the coincidence grids of these gating tubes. The necessary 480-cps square-wave signal is obtained from a frequency-doubler whose input is also fed from the common 240-cps source.

Symmetry of the 480-cps signal is controlled, permitting the instant of switching to be adjusted with vernier accuracy to the de-

sired angular position of the heads on the tape. With a rise time of about  $0.05 \mu\text{sec}$ , this 480-cps square wave gives the final go signal to each switching operation, so that interruption of the composite signal is exceedingly brief.

The 480-cps square wave, like the two 240-cps control signals, is fed through a phase splitter, one phase

of the 480-cps control-signal from gate 1, so it too goes suddenly positive at the screen grid of this second gate and the tube conducts.

Since this rapid occurrence is coincidental with the negative phase of the 480-cps signal at gate 1, the gate ceases to conduct at the same moment that gate 2 begins to conduct. Gates three and four are both in the negative-going portion of the 240-cps control signal which is applied to them, so that gate 2 is, at this moment, the only one conducting. The same sequence of events occurs next at gate three, as the rotating head disk reaches approximately another 90 deg of rotation.

### Retrace Control Switcher

Since approximately two television lines of information are duplicated from track to track on the magnetic tape, the bottom of one line contains the same information as the top of the succeeding track. A rearrangement of the get-ready, go signal procedure is desirable to locate the moment of switching.

If the line carrying the 480-cps wave is opened before it feeds the corresponding phase splitter, and this signal is delayed momentarily in accordance with the synchronizing information in the television signal, the switching can be done during retrace when the crt beam is off the television screen. The arrangement used is shown in Fig. 8. The retrace switcher control unit, shown in Fig. 9, contains a 480-cps multivibrator oscillator, which is locked jointly to the 480-cps photocell-derived signal and to the synchronizing pulses in the demodulated r-f video signal. Over a relatively narrow range, this oscillator's frequency may be varied, effectively delaying its output with respect to the 480-cps switcher signal, so that the exact moment at which the outgoing 480-cps square-wave goes positive may be made to coincide with a desired point in the controlling video signal.

As illustrated in Fig. 10, the switching time may be positioned on the back porch interval, which places the switching transients on the extreme left-hand side of the reproduced picture, out of view. Should the video signal fail, the multivibrator oscillator in the re-

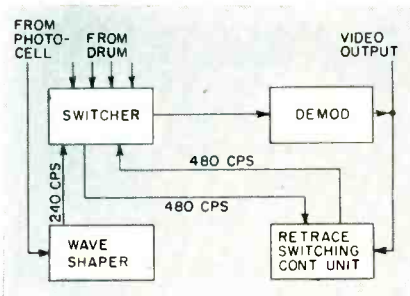

FIG. 8—Retrace control switcher prevents overlap of information in playback

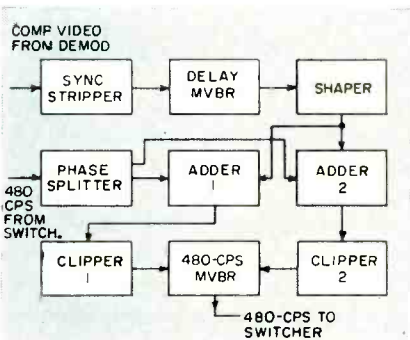

FIG. 9—Elements of retrace switching control unit

going to gates one and three, the other to gates two and four.

The sequence of operations, then, begins with the appearance at the control grid of gate 1 of the r-f signal from head 1. The 240-cps control signal is at this time going positive. The phase of the 480-cps square wave is such that it too goes suddenly positive at one point in the rotation of the head disk. At this moment, the gating tube begins to conduct r-f.

All four gating tubes are parallel in their outputs, and an r-f video signal is fed to the input of the demodulator, which follows the switcher.

About 90 deg later in the rotation of the head disk, the 240-cps delayed signal goes positive at the control grid of gate tube 2. This tube is fed from the opposite phase

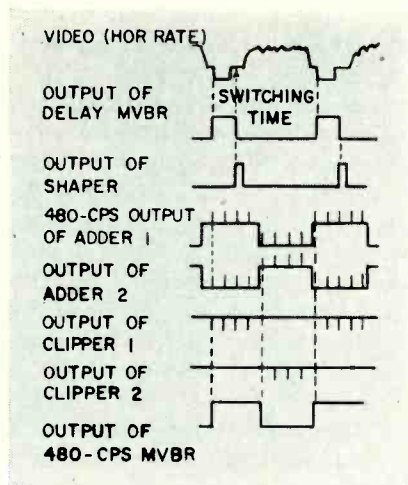

FIG. 10—Waveform relationships in retrace switching control unit

trace switcher will continue to send triggering pulses to the 480-cps multivibrator, insuring continuous output regardless of the nature of the incoming video signal.

If, for example, a synchronizing pulse should be missing from the train coming off the tape and the time should arrive when switching must occur from one head to the next, the unit will wait for a brief interval. When no synchronizing pulse appears, the unit will switch to the next head anyway, with minimal loss in signal from the tape.

The 480-cps signal, which originates in the sequential gating switcher, is thus modified and suitably delayed by the retrace switching control unit, so that, upon reinjection, it will cause the gating tubes to switch from channel to channel only at such a point in the sequence of video signals that there will be no visible effect.

#### Processing Amplifier

Because of the distortion which is necessarily introduced into the signal by the closeness of carrier and modulating frequency in the f-m system, because of the shape of the overall bandpass and because of the effect of minute amounts of hunting in the rotating drum, the waveform of the demodulated composite video signal suffers a certain amount of deformation. This is of minor importance to the video information, but of considerable importance to the shape of synchronizing pulses. A processing

amplifier therefore follows the demodulator.

Through relatively conventional video techniques it strips off synchronizing information, reconstitutes it and adds it to the video information once more, to produce a composite signal which conforms to FCC television transmission standards.

The relative level of picture and synchronizing signals may be varied in the processing amplifier. From this chassis is derived the information which governs the retrace control switcher. The monitor and video line outputs are also fed from this unit.

#### Present Development

Performance of the video-tape recorder, in the form in which it exists in 1957, has been considerably improved over that obtained from the experimental unit first displayed in 1956.

The development of special tape, horizontally oriented, with surface smoothness much finer than that normally provided (or needed) in audio tape, specially formulated oxides of particularly good short-wavelength resolution capability and improved mechanical characteristics have all combined to make possible the routine realization of signal-to-noise ratios of 34 to 36 db, with occasional attainment of ratios as high as 40 db.

Head manufacturing techniques have also been refined reducing the abrasion effect, both on the tape and on the heads, to the point where a substantial number of heads have proved usable well beyond the 100 hours which were originally considered a practical norm. Tape too is proving capable, under these improved conditions, of being reproduced many more times without deterioration and of being recorded and rerecorded for an aggregate of well over the 100 passes of the revolving heads which at first were thought to be the practical maximum.

#### Head Deterioration

Deterioration in heads due to wear does not produce deterioration either in resolution or in the linearity of grey-scale transfer; in fact, resolution improves slightly

as heads wear and only the eventual increase in noise tells of the approaching end of the useful life of the heads.

The same is true of tape. Neither resolution nor grey-scale linearity are affected by the gradual abrasion of the tape which occurs in use. Instead, the signal-to-noise ratio slowly begins to deteriorate, signifying the end of the useful life of the tape.

Linearity of grey-scale is an inherent advantage of the video-tape recording process due to the modulation system used. There are no operating controls on the recorder which are capable of affecting the linearity of the grey-scale transfer characteristic.

Differential gain measurements typically give readings of under 10 percent; this remains constant, being quite independent of head or tape condition. The live appearance of the video-tape reproduction is as much due to linear grey-scale transfer characteristic as to any other operating characteristic of the machine.

Resolution of better than 300 lines, with high contrast ratio, is readily obtained.

#### Tape Duplication

Experience with the recorder in daily network operation has established the practicality of making duplicate tapes from an original. While there is no method of making copies except by connecting one or more video-tape units as recorders, while another is used as a replay machine, the number of copies which may be made in this manner is substantially unlimited.

First-generation copies of an original video-tape recording are deteriorated in hardly any visible way, resolution and grey-scale linearity being substantially identical to the original. A slight rise in noise occurs, but if this is already well below visibility in the original the copy will appear virtually the same as the original.

The author thanks the many contributors who made this article possible.

#### REFERENCES

- (1) Enzo Cambi, Trigonometric Components of a Frequency-Modulated Wave, *Proc IRE*, p 42, Jan. 1948.





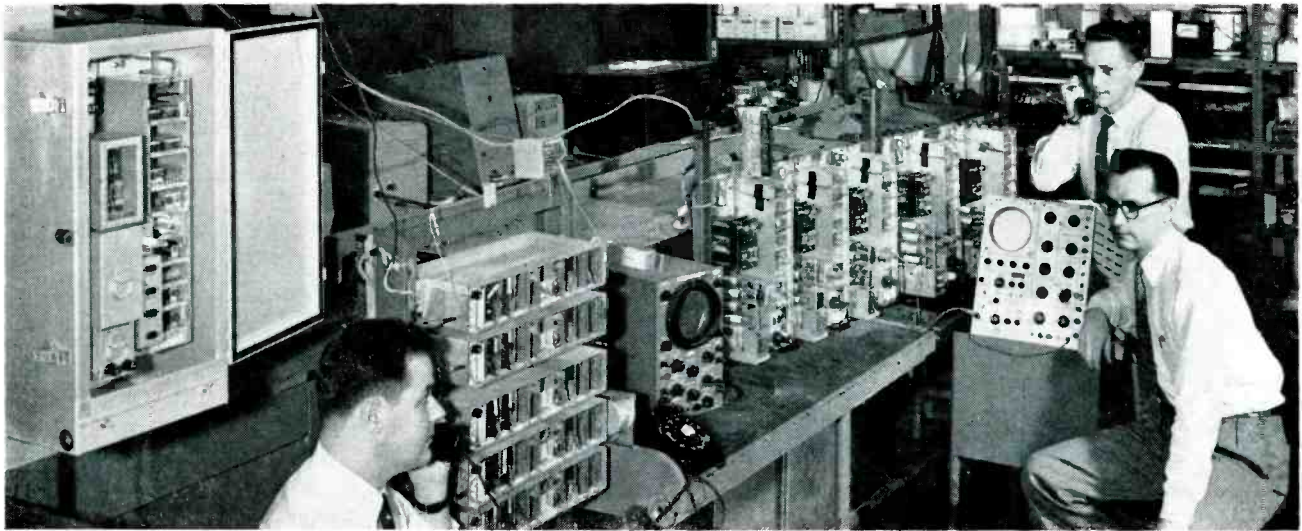

Laboratory setup for checking overall transmission quality of transistorized carrier system

# RURAL CARRIER SYSTEM

**SUMMARY** — Selective calling of up to ten telephone subscribers per wire pair is possible with transistorized transmitter and receiver using double-sideband transmission and operating over line losses of 35 db. Subscriber receiver response is flat within 0.5 db as a result of circuit stabilization

**A**PPPLICATION OF CARRIER transmission to rural telephone lines has been rather slow for many reasons, mainly economical. Systems could not, until recently, be proven-in over such short distances due to high cost per channel. Now that the cost of the equipment and maintenance has become competitive with that of constructing new wire lines, subscriber carrier operation becomes feasible.

Numerous requirements must be met. Overall quality of transmission should not be substantially inferior to that in other types of carrier equipment, which means that the transmitted bandwidth response should be flat between 250 to 2,500 cps. Crosstalk and noise must be kept low and reliable operation under extreme climatic conditions should be maintained.

Use of transistors takes advantage of low power drain and small size, which is always attractive for

pole-mounted units especially if standby power is required.

## System

The system shown in Fig. 1 uses double sideband transmission and operates over line losses up to 35 db at carrier frequencies.

The five channels at the central office connect to the line through a line coil. The subscriber terminals drop off at convenient points along the line. Since carrier channels operate over voice-frequency physical circuits, it is necessary to isolate all subscriber telephones connected across the line. This isolation is accomplished by pole-mounted low-pass filters, which present high bridged impedance to the carrier frequencies.

Ringling and dialing are performed by interrupting the carrier while compandors are used, optionally, in cases where excessive line noise or crosstalk is encountered.

Fig. 2 and Fig. 3 show in block form the arrangement of circuit.

Voice signals from the central office line are routed through the hybrid and level adjusting pads to the modulator in the transmitter. When compandors are used, the compressor unit replaces the pads. The modulated wave is amplified to the line level and passed through transmitting filter to the line.

## Subscriber Signals

The signals from the subscriber are selected by the receiving filter, adjusted to proper level, amplified, detected and delivered to the hybrid through the expander, if used, or through the voice-frequency receiving pads.

The voice-frequency signal is then routed through the hybrid into the central office.

Transmission at the subscriber end is essentially the same. Dialing by subscriber is accomplished as



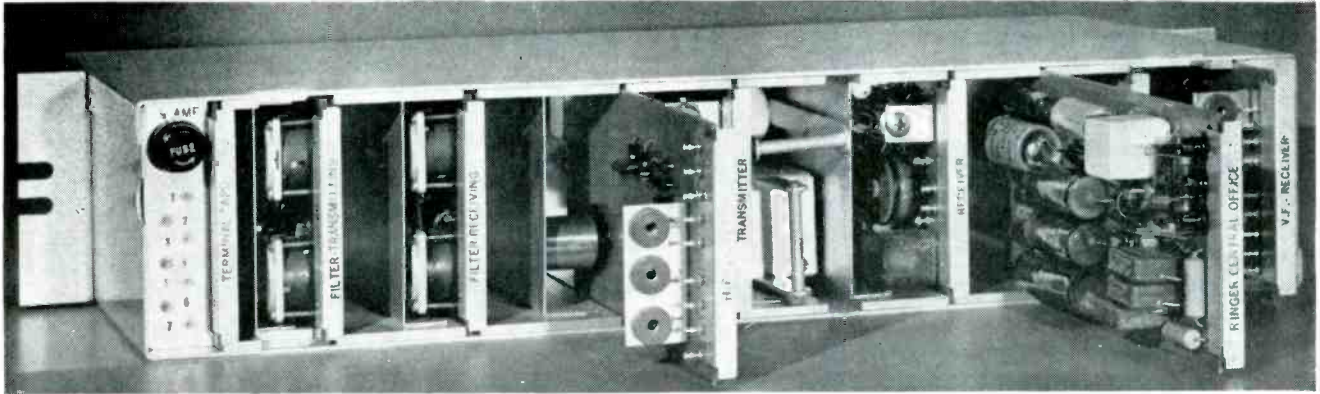

Central office terminal shows how individual circuits are arranged on cards for easy insertion and removal

By **B. R. STACHIEWICZ**

*Telecommunication Division  
Stromberg-Carlson Co.  
A Division of General Dynamics Corp.  
Rochester, New York*

# USES TRANSISTORS

follows: when the subscriber lifts his receiver a d-c circuit through the dial contacts, voice-frequency loop and the winding of relay *SR* is completed. Direct current, supplied by a power pack located on the pole-mounted terminal, flows in this circuit. Upon dialing, this current is interrupted causing the *SR* relay to operate. The contacts of this relay are arranged to short the output of the transmitter when the station is on-hook or the dial contacts are open. When the subscriber goes off-hook, the channel carrier is automatically transmitted. Thus dialing information

is transmitted by switching the carrier frequency on and off.

At the central office the interrupted carrier is picked-off at the base of the detector stage, amplified and rectified by the signal a-c amplifier and used to drive relay contacts in series with the ring wire from the central office. The operation of this relay completes the d-c circuit through the hybrid winding and the central office relay. Pulses of d-c are thus obtained in the central office relay winding, which reproduce the dialing pulses generated at the subscriber end.

To call the subscriber, the ring-

ing voltage of any frequency up to 66 $\frac{2}{3}$  cycles from the central office modulates the carrier wave transmitted to the subscriber. At the subscriber terminal those signals are amplified and detected in the receiver amplifier circuit. A special d-c amplifier located on the ringer card amplifies and rectifies the ringing signal and drives a mercury relay. The armature of the relay vibrates at the ringing frequency and the contacts are connected in the vibrator circuit. The output of the vibrator is applied to the subscriber's voice-frequency extension at a magnitude that operate the

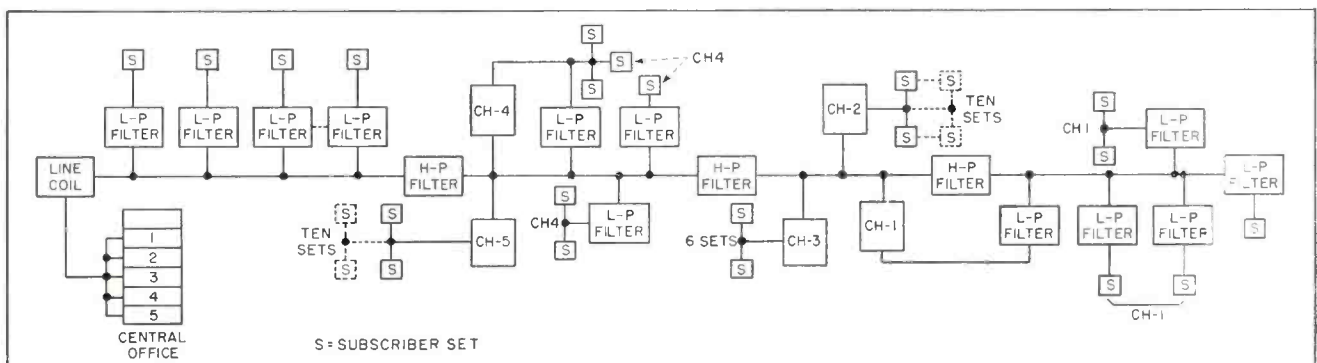

FIG. 1—Block diagram shows how rural subscribers are serviced by one wire pair





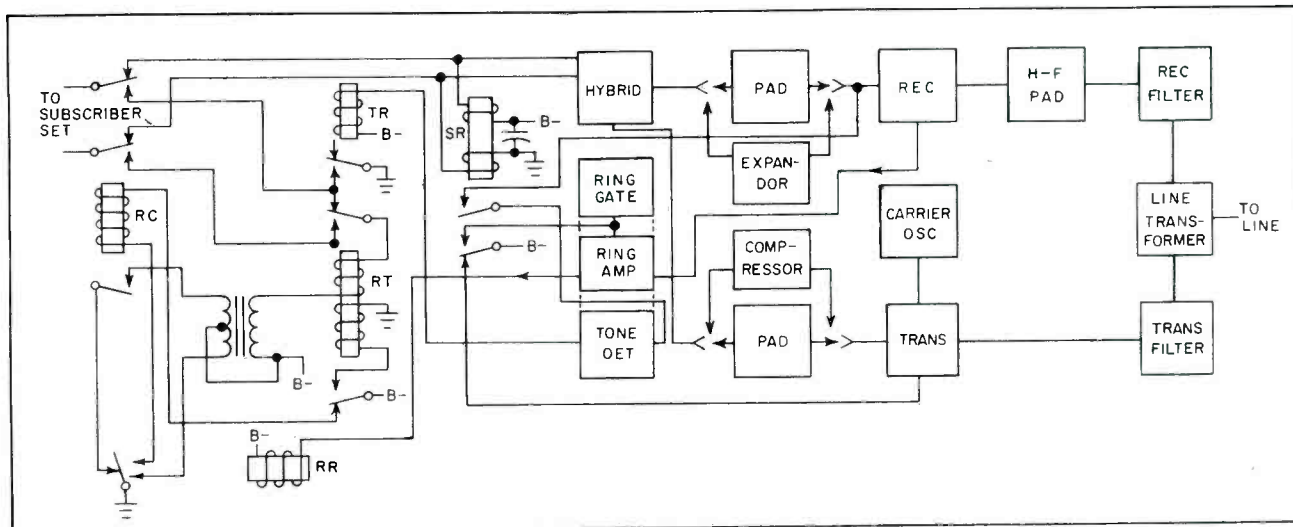

FIG. 3—Subscriber terminal equipment block diagram shows how ringing signal is fed from receiver to ringing amplifier to relay RR which vibrates at the ringing signal frequency and activates other relays to feed signal to subscriber set

FIG. 4—Schematic of transistorized receiver (right) used in both terminal sets

ratio of current variation. However, the solution adopted consists in regulating the input stage only as much as would be required to prevent circuit overload under the condition of maximum input signal and to achieve the remaining regulation in the output stage. Thermistors are used as variable elements to achieve slower action.

A common-base configuration of the first amplifier stage was dictated by several considerations. Feedback could not be used due to the variable gain requirement and consequently no easy method of flattening the frequency response and of combating distortion and intermodulation effects was on hand. The frequency cut-off of the grounded-base transistor is extended by a factor of  $1/1-a$  over the grounded emitter response. Better linearity of characteristics can also be obtained with the base grounded resulting in decreased intermodulation and distortion products.

The high output impedance of this configuration was utilized by connecting the thermistor as the a-c load impedance of the stage. The gain obtained is then directly proportional to the value of the load impedance.

The second stage consists of a conventional grounded-emitter transistor amplifier. Both shunt and

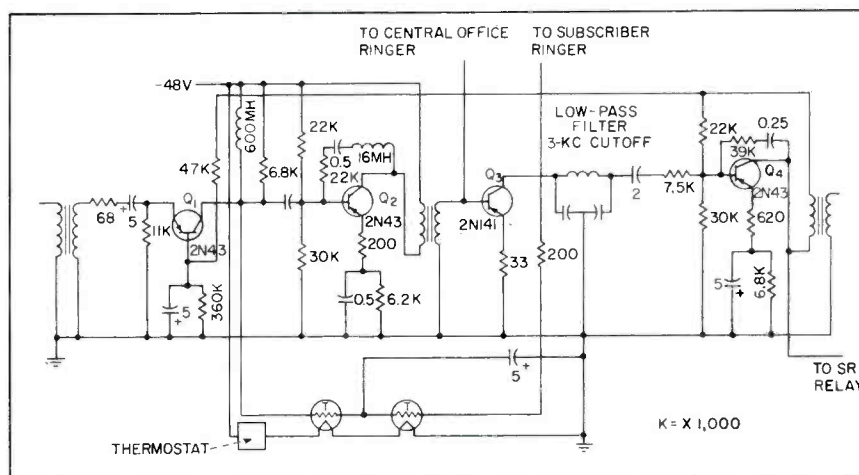

series feedback are used to stabilize the input and output impedances. Frequency response over the required range of 24 to 138 kc is held flat within  $\pm 0.5$  db. Feedback is sufficient to stabilize the gain of the stage against manufacturing variations in transistors and against varying temperature and voltages.

### Output

The output of this amplifier is transformer-coupled to the detector stage. The speech intelligence is recovered and the d-c current resulting from the rectified carrier is used as the control current in the regulator loop. A thermistor, the resistance of which varies with this current, is the load. Stage gain is thus proportional to the load impedance and additional regulation is obtained.

The low-pass filter following this

stage eliminates higher frequencies present and passes the voice signals to the output amplifier. Here, shunt and series feedback are used to stabilize the gain and the impedances. An output of up to +7 dbm is obtained with distortion not exceeding 5 percent.

Indirect heating is provided for thermistors under low ambient temperatures to insure proper circuit operation.

Climatic tests performed on this circuitry indicated an output stability of  $\pm 1$  db under all conditions with distortion not exceeding 4 percent at the output.

The author acknowledges the work of R. L. Layburn who developed most of the circuitry and D. F. Jamieson and H. V. Buck, the electrical and mechanical engineers. Filters and transformers were designed under W. L. Brune.

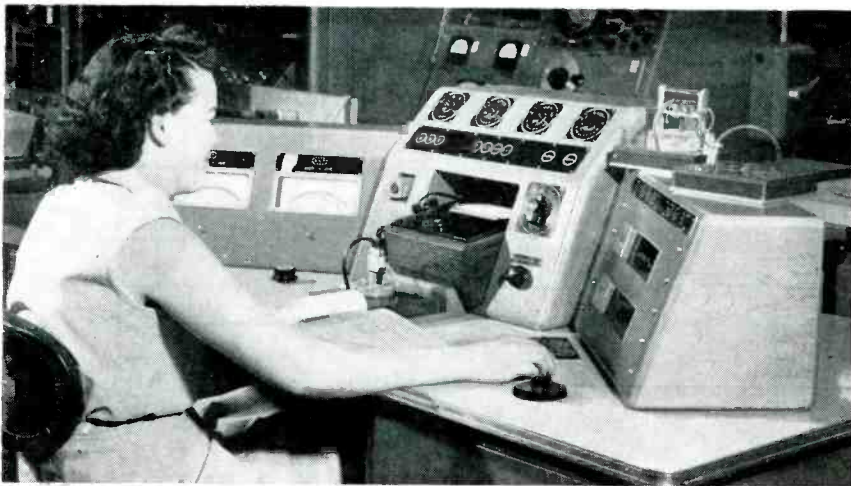

Production type core tester (left) has automatic testing features. Yield at first operational test point increased from 70 to 90 percent on introduction of this method. Developmental model of core tester is shown at right

# Core Tester Simplifies

By **R. W. ROBERTS**

*Director Systems Department  
Westinghouse Electric Corp.  
Pittsburgh, Pa.*

and

**C. G. HORSTMAN**

*Specialty Transformer Department  
Westinghouse Electric Corp.  
Greenville, Pa.*

**SUMMARY** — Procedure using results obtained from dynamic tests made on core material prior to winding simplifies magnetic amplifier design by proper interpretation of standard test values of circuit constants. Normalized design equations for the most common magnetic amplifiers are given and their application to specific design problems discussed

**D**ESIGNING A REACTOR for a magnetic amplifier requires that a choice be made of core and type of magnetic material.

Since it is not practical to measure core characteristics under actual amplifier operating conditions in production, these conditions are simulated in a core tester. This article will describe a method for core test<sup>1,2</sup>. It consists of using a half-wave rectified current to drive the core flux to saturation once each cycle. A d-c control current resets the flux during the off half cycle and an average-sensitive voltmeter measures the voltage in a pickup winding as shown in Fig. 1.

## Core Correlation

The correlation between core test and amplifier operation rests on the

basic assumption that a core, when operating in an amplifier, reduces the volt-time integral across the load by absorbing or supporting a value of volt-seconds proportional to the flux change in the core. Under this condition, the voltage induced in the pick-up winding of

the tester corresponds to the voltage induced in the amplifier output winding when the core controls the load voltage and under conditions of equivalent applied control magnetizing force, the amplifier output can be calculated from core test measurements.

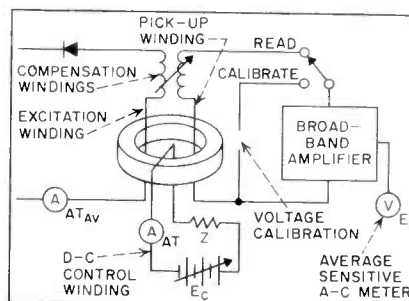

FIG. 1—Test circuit of constant-current flux-reset method of measuring dynamic core properties

## Design Procedure

A typical curve of induced voltage,  $V_i$  against d-c control ampere turns  $AT$  for an oriented, 50-percent nickel-iron core is shown dotted in Fig. 2.

In application it is convenient to represent the linear portion of the core-test curve by a straight line approximation. The equation is:

$$V_i = G_i AT + C$$

where





Operator applies finishing touches to a group of nickel-iron alloy cores (left) while another operator inspects finished group of magnetic amplifier reactors (right)

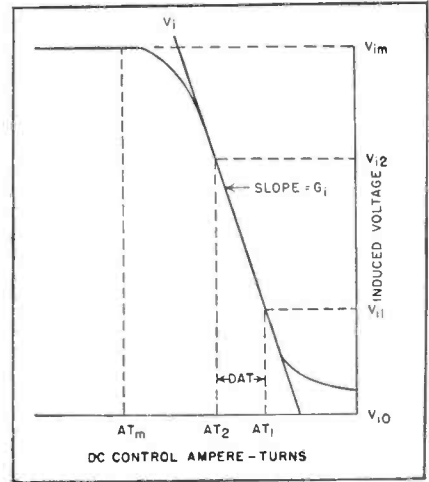

FIG. 2—Linear region of dynamic core test data shows test points

# Ferro-Amplifier Design

$G_i = \text{slope} = (V_{i2} - V_{i1}) / \text{DAT}$   $AT = \text{total control ampere turns and } C = V_{i1} - G_i AT_1.$

The general steps followed in designing a magnetic amplifier reactor are:

Assume a core size and material appropriate for the application.

Assume percentage of available winding area to be used for load windings. This assumption is

based on experience and type of application.

Compute load winding turns necessary to support supply voltage and compute wire size to fit in available space.

Compute winding resistance and power output level to suit requirements. This is similar to a normal transformer design problem and depends on insulation system and

other factors.

Design control and bias turns to meet operational requirements. Here the core test data is applied directly to the design. The amplifier performance can be expressed as a function of core properties and the number of turns. These expressions are solved for the control and bias turns to yield the required performance.

Select wire sizes for control and bias windings so windings will fit in available space and so winding resistance will meet other operational requirements.

Calculate other facets of performance characteristics and check with requirements.

As in all transformer and reactor design, there is no short, simple path to the ultimate and it should be realized that in going through these steps some retracing is necessary. The primary advantage of having the core test data available is that a great deal can be done by calculation rather than by experiment.

## Amplifier Equations

To develop the expressions for amplifier performance in terms of core test data, consider the half-

Table I—Normalization of Core Test Values

Direct Value	Normalized for Core Size	Equivalent Magnetic
$V_{i0}$ (volts/turn)	$\frac{V_{i0}}{A_c}$ (volts/turn/sq. in.)	$B_m - B_r$ (gauss)
$AT_1$ (ampere-turns)	$\frac{AT_1}{l_m}$ (ampere-turns/inch)	$H_1$ (oersteds)
$DAT$ (ampere-turns)	$\frac{DAT}{l_m}$ (ampere-turns/inch)	.....
$V_{im}$ (volts/turn)	$\frac{V_{im}}{A_c}$ (volts/turn/sq in.)	$B_m$ (gauss)
$G_i$ (volts/amp-turn <sup>2</sup> )	$\frac{G_i l_m}{A_c}$ (volts/amp turn <sup>2</sup> -in.)	(gauss/oersted)

where  $B_m - B_r = V_{i0} / 2.22 f A_c X 10^{-8}$ ,  $B_m = V_{im} / 4.44 f A_c X 10^{-8}$ ,  $H_1 = 0.4 \pi A T_1 / l_m$ ,  $\mu_d = G_i l_m / 0.4 \pi X 4.44 f A_c X 10^{-8}$ ,  $A_c$  is the effective core cross-section area in sq in.,  $A_c$  is the effective core cross-section area in cent. in.,  $l_m$  is the mean magnetic path length in inches and  $l_m$  is the mean magnetic path length in centimeters.

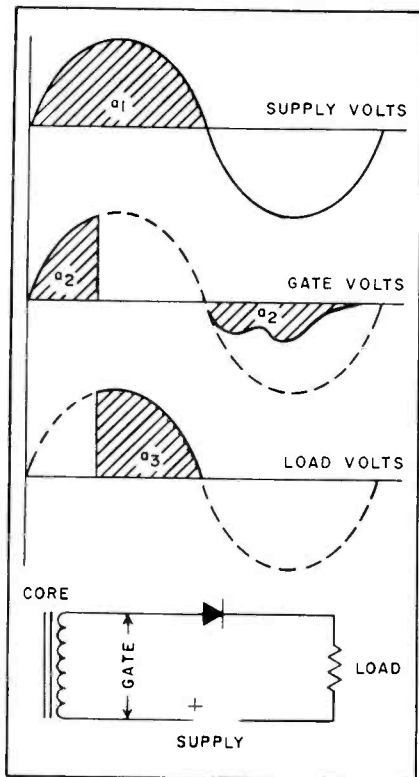

FIG. 3—Ideal half-wave amplifier characteristics used to develop core test data expressions

wave self-saturating amplifier of Fig. 3.

From Kirchoff's laws, load voltage equals supply voltage minus voltage across gate winding. Integrating this relation with respect to time over a positive half cycle results in

$$\text{area}_3 = \text{area}_1 - \text{area}_2$$

The a-c supply voltage is read in rms volts, the load voltage in d-c volts and the gate voltage on an average sensitive, rms calibrated meter so

$$V_L = 0.45(V_{a-c} - V_G)$$

$V_G$  is obtained from the core test data as  $V_{i1}$ , induced voltage per turn.

$$V_G = N_G V_i$$

The correlation between core test values and the characteristic curve of a half-wave amplifier is shown in Fig. 4.

For values of ampere turns below the cutoff point where the core no longer reaches saturation the load current is given approximately by

$$I_L = AT/N_G$$

The equation for practical cases

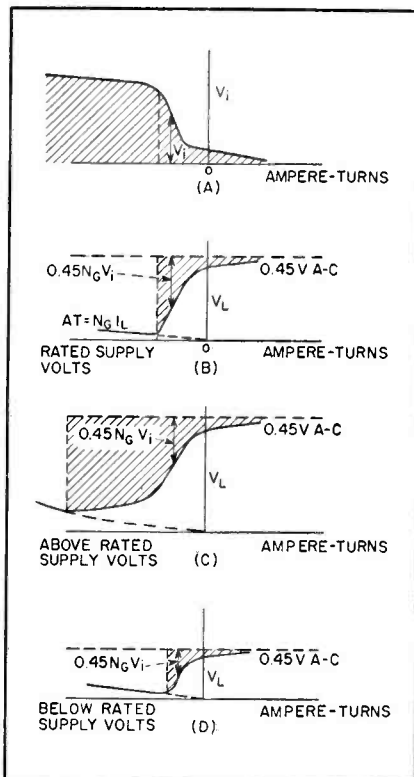

FIG. 4—Typical core-test curve (A) and half-wave amplifier characteristic curves (B, C and D) demonstrate correlation

considering rectifier and winding losses is

$$V_L = 0.45P(V_{a-c} - N_G V_i)$$

where  $P$  is the loss factor  $P = R_L / (R_L + R_w + R_F)$ ,  $R_L$  is the load resistance,  $R_w$  is the winding resistance and  $R_F$  is the rectifier equivalent forward resistance.

Rectifier reverse leakage can be approximately considered as:

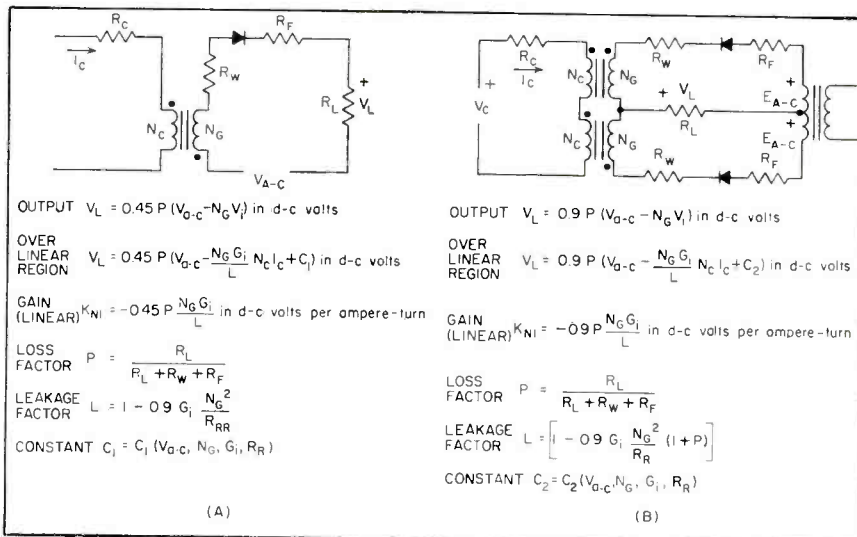

FIG. 5—Circuit and core-test equations for half-wave amplifiers (A) and a full-wave center-tapped amplifier (B)

$$V_L = 0.45P[V_{a-c} - N_G G_i(N_G I_c + C_1)]$$

where  $L =$  leakage factor  $= L/1 - 0.9 G_i (N_G^2/R_{RR})$  and  $C_1 = 0.9 N_G (V_{a-c} - N_G C/R_{RR})$ .

The quantity  $R_{RR}$  is equal to rectifier equivalent reverse resistance,  $N_G I_c$  is equal to applied control ampere turns and  $C$  is equal to  $V_i - G_i AT$ .

Figures 5 and 6, give the design equations for several commonly used circuits.

In full-wave amplifier circuits the cores are complementary in resetting and this reduces the power necessary to normally reset the cores.

The accuracy of the calculations depends on the average value of net magnetomotive force effective in producing flux reset, regardless of wave form, and gate circuit limiting of the rate of flux reset so it does not appreciably affect the total amount of flux reset.

### Standard Values

Important features of the core test characteristic curve are expressed by a set of standard test values.

The peak value of excitation ampere turns  $AT_p$  must assure saturation of the core. This value can be set on the basis of the d-c magnetic properties of the material since the magnetization time lag is normally small in the positive saturation region. The values of the test points  $V_{i1}$  and  $V_{i2}$  must be chosen to lie within the linear re-



gion of the curve for all cores of the type to be tested. In practice, it is possible to specify values of  $V_{i1}$  and  $V_{i2}$  that satisfactorily represent the linear region for all cores of any given size and material.

Measurement of the saturation-induced voltage,  $V_{im}$ , is most convenient if performed at a specified value of control ampere turns  $AT_m$ . This point is chosen on the basis of the largest anticipated effective a-c loop width. The standard test values shown in Fig. 2 and their interpretation are as follows:

$V_{i0}$  is the induced voltage at zero control ampere turns. This value corresponds to the difference between the residual flux and the saturation flux.

### Gain

$AT_1$  is the ampere turns required for a specified induced voltage value  $V_{i1}$  approximately one-third of the saturation voltage.

$DAT$  is the differential ampere turns required to change induced voltage from  $V_{i1}$  to a second value of induced voltage  $V_{i2}$  approximately two-thirds of saturation voltage. The inverse of this value corresponds to the slope or gain of the control characteristic curve. This gain corresponds to the differential permeability of the effective a-c hysteresis loop followed by the core in amplifier operation. The gain of a core,  $G_i$ , is defined by

$$G_i = \frac{V_{i2} - V_{i1}}{DAT} = \text{volts/turn/amp-turn.}$$

$V_{im}$  is the saturation-induced voltage as obtained at a large specified value of control ampere turns  $AT_m$ . This value of induced voltage corresponds approximately to a flux change from positive saturation to negative saturation each cycle. It is very nearly the maximum voltage per turn the core is capable of supporting at the test frequency.

Core test values expressed in actual values of induced voltage per turn and ampere-turns of control current are most useful for amplifier design work. For other purposes, such as core-size influ-

ence and material property investigations, normalization of core test values is necessary. A summary of these normalized values is given in Table I.

### Normalizing

Normalization of core test values removes the gross effects of core size but core shape has also been found to influence core magnetic properties.<sup>3</sup> The critical parameter is the ratio of minimum to maximum magnetic path lengths. For toroidal cores this corresponds to the ratio of inside to outside diameters or id/od ratio. The only core property affected by the id/od ratio is the core gain. In terms of normalized core gain or differential permeability, the id/od influence is given for Hipernik V material approximately by:

$$\mu_d = \mu'_d 0.144[(1+r)/(1-r)] \text{ if } r < 0.75$$

$$\mu_d = \mu'_d \text{ if } r > 0.75$$

where  $\mu'_d$  is the differential permeability for a thin ring core and  $r$  is the id/od ratio.

Typical ranges of core tester characteristics are given in Table III for the common types of magnetic materials.

### REFERENCES

- (1) J. R. Conrath, Magnetic Amplifier Gapless Core Tests, *ELECTRONICS*, 25, p 119, Nov. 1952.
- (2) R. W. Roberts, Magnetic Characteristics Pertinent to the Operation of Cores in Self-Saturating Magnetic Amplifiers, *Comm and Elect, AIEE*, p 682, Jan. 1955.
- (3) R. W. Roberts and R. I. VanNise, Influence of ID/OD Ratio on Magnetic Properties of Toroidal Cores, *Elect Eng*, 74, p 910, Oct. 1955.

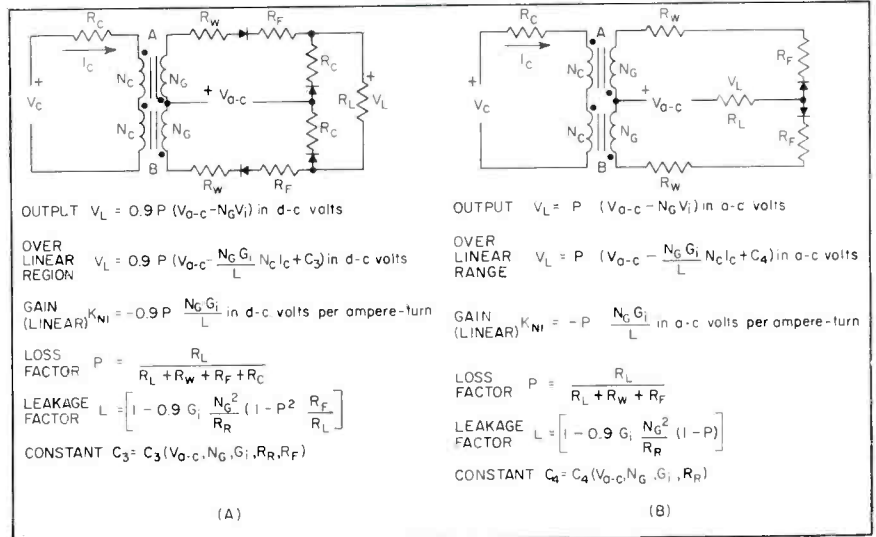

FIG. 6—Circuit and core-test equation for full-wave bridge-circuit amplifier (A) and full-wave doubler-circuit amplifier (B)

Table III—Typical Core Test Magnetic Characteristic Ranges for Various Materials at 400-cycles

Core Material (Toroidal Cores)	Test Values			Test Conditions				
	$B_m - B_r$ kilogauss	$H_d$ Oersteds	$d$	$B_m$ kilogauss	$AT_p$ Oersteds	$B_1$ kilogauss	$B_2$ kilogauss	$A - T_m$ Oersteds
Highly-oriented 50 percent nickel- iron (2-mil strip Hipernik V)	0.9 to 1.4	0.15 to 0.24	15 to 50 $\times 10^4$	14.0 to 15.3	2.0	10.5	21	0.359
Non-oriented 50 per- cent nickel-iron (2-mil strip Hipernik)	1.4 to 3.5	0.08 to 0.16	15 to 50 $\times 10^4$	12.0 to 14.0	2.0	10.5	21	0.359
Mo-permalloy and Supermalloy type Materials (1 or 2-mil strip)	1.3 to 3.1	0.015 to 0.05	40 to 90 $\times 10^4$	5.7 to 8.7	1.0	5.25	10.5	0.135
Oriented 3 percent silicon-iron (5-mil strip Hipersil)	1.3 to 3.5	0.39 to 0.54	2.6 to 11 $\times 10^4$	14.4 to 17.5	4.0	10.5	21	1.58

# VIDEO SCANNER

By E. J. OELBERMANN

Senior Engineer  
Haller, Raymond and Brown, Inc.  
State College, Pa.

**SUMMARY** — System under development for determining differences in two photos taken from same point in space at different times produces a standard width line at each point of contrast change as scanner passes over pattern. Applications include aerial surveys and study of microscopic growth

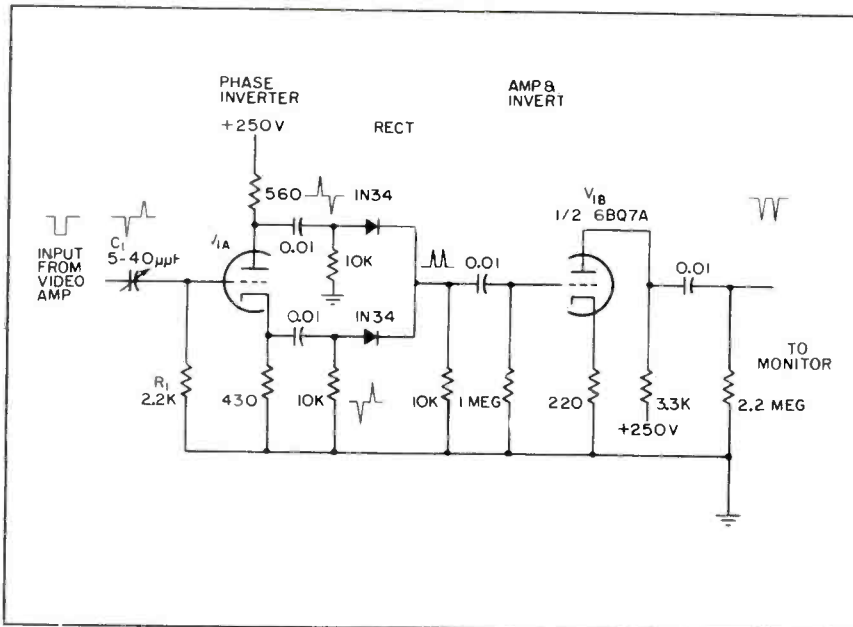

FIG. 1—Video differentiator and full-wave rectifier with waveforms at various points

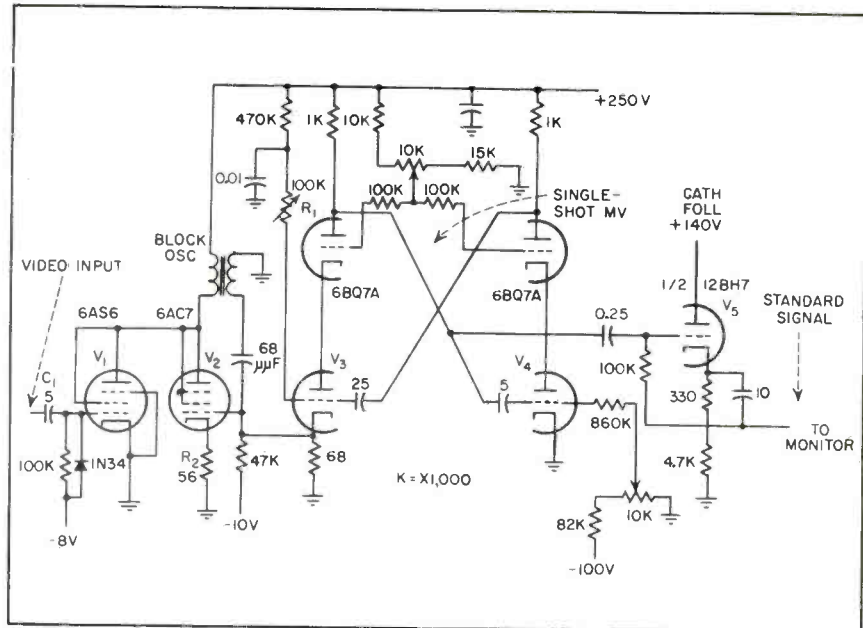

FIG. 2—Blocking oscillator and single-shot multivibrator provide standardized constant amplitude, constant line-width patterns from differential signal

**E**XPERIMENTS are being conducted to determine whether two patterns or photographs can be recognized electronically as being fundamentally identical, although they differ completely in relative tone and density, even to the extent of being inverses of each other.

The circuit shown in Fig. 1 is used to differentiate and full-wave rectify the video signal obtained by scanning a simple pattern with a vidicon tv camera.

Differentiation of the video waveform is provided by  $R_1$  and air trimmer capacitor  $C_1$ . Tube  $V_{1A}$  is a split-load phase inverter whose output is full-wave rectified by the two crystal diodes and then amplified and inverted by  $V_{1B}$ .

Since the duration and intensity of the differentiated signal depends on the difference in tone across a contrast border, two differentiated full-wave rectified signals will not agree perfectly unless the tones and contrasts in each original pattern are identical.

Figure 2 is a schematic diagram of a video standardizer circuit used to produce standardized constant-amplitude, constant-line-width patterns from the differentiated signals. Biased blocking oscillator  $V_2$  generates 0.1-microsecond trigger pulses for the single-shot multivibrator consisting of tubes  $V_3$  and  $V_4$ . The output of the multi-vibrator consists of constant amplitude pulses whose duration may be controlled between 0.1 and 0.4 microsecond by varying  $R_1$ .

When the blocking oscillator produces 0.1-microsecond pulses with a peak amplitude of 20 volts, the peak current through  $R_2$  is approxi-



# Matches Photo Patterns

mately 330 ma. The average current at a pulse repetition rate of 1 mc is approximately 20 ma because of the sinusoidal pulse shape. Trigger signals are coupled directly from the cathode of the blocking oscillator to the cathode of  $V_3$  which is normally conducting. Positive-going standardized pulses are then coupled through cathode follower  $V_5$  to the video monitor.

## Pattern Matching

Figure 3 is a series of photographs of the tv picture obtained at consecutive stages in the video processing of a simple pattern. The pattern in Figure 3A contains two tonal extremes which might be encountered in any experiment—a white object on a black field and a black object on a white field. The simple differentiated picture in Figure 3B is the normal differentiated signal obtained at the grid of  $V_{14}$  in Fig. 1. Figure 3C is the full-wave rectified input signal to the blocking oscillator in Fig. 2 and Figure 3D is the standardized output signal obtained from the single-shot multivibrator in Fig. 2.

Horizontal tv scanning is not the best type of scanning to use for this purpose, as evidenced by the break in the tops of the two circles in Fig. 3D. These breaks are explained by the fact that the direction of the scanning spot was tangent, rather than normal, to the contrast border at this point. This condition can be corrected by

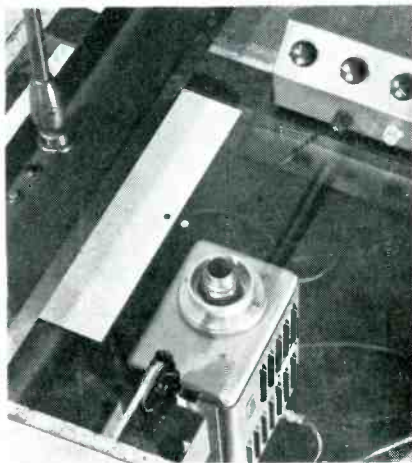

Camera setup used in experimental pattern matching tests shown in Fig. 3

using an isotropic scanning system.

The rapid-scan tv signal, however, permits slow movement of the original patterns so that the patterns being matched need not be stationary.

The amount of high-contrast detail in the geometrical pattern can be measured by the current drain in the multivibrator circuit. Since a constant amount of energy is delivered for each differentiated pulse which is above the bias level of the blocking oscillator, the plate current drawn by the multivibrator varies directly with the amount of detail present in the original pattern. Such a process might be useful for statistical studies of photographic data.

The ultimate purpose was to develop a variable-width gate signal

to gate out all corresponding points in another identical pattern whose video scanning signal has been delayed by a fraction of a micro-second.

This is perhaps the only way of obtaining a perfect null between two slightly imperfect patterns, where the imperfections can be masked off by the broadened lines in the gate signal. In this manner it is possible with alignable patterns to display only the new information.

The patterns shown in Fig. 3 represent approximately one sq in. of scanned area. To work at short distances of the order of one in. it was necessary to modify the standard 16-mm lens assembly of the vidicon camera by building an adjustable lens mount as shown on the front of the camera.

## Applications

The matching technique studied in these experiments can be used for matching areas on various types of photographs when the photographs have been taken from the same point in space. The resolution of this system is, however, limited by the resolution of the tv camera so that only small areas can be examined using the present scheme.

The techniques described were developed under Air Force Contract AF 30(602)-1404 in conjunction with the Intelligence Laboratory of Rome Air Development Center.

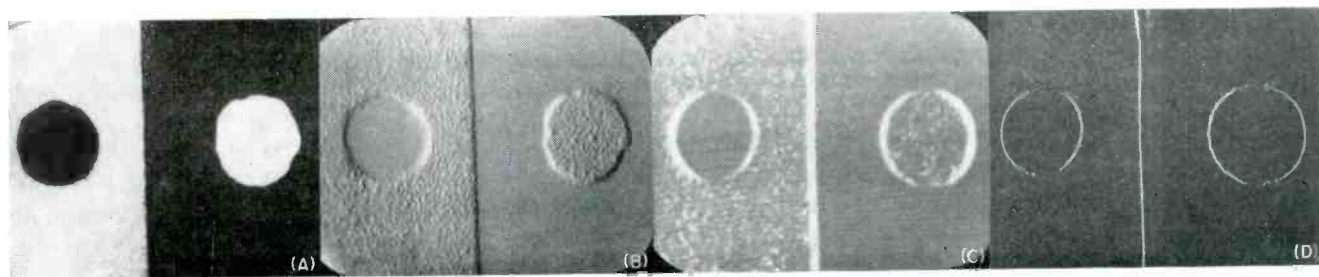
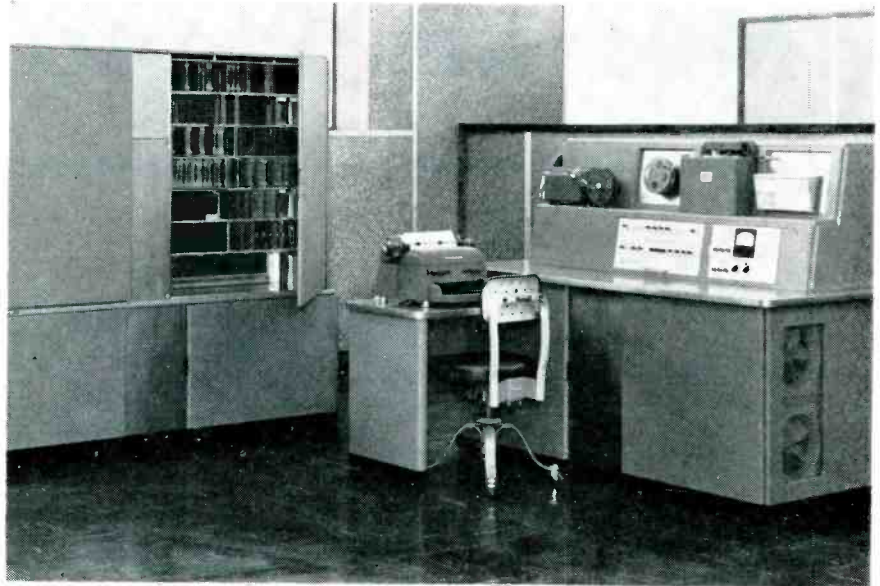

FIG. 3—Original video pattern (A) when differentiated (B) and rectified (C) is converted to standardized line-width pattern (D)

By T. H. BONN

Remington Rand Univac  
Division of Sperry Rand Corp.  
Philadelphia, Pa.



Series-type magnetic amplifiers are used throughout Univac magnetic computer

# MAGNETIC COMPUTER

**SUMMARY** — Complementing series-type amplifiers handle information rates up to 2.5 mc in all-magnetic computer operating at 660-kc information rate which, when properly programmed, has a speed equal to Univac I. Design considerations included in the 1,500 magnetic amplifier circuits and various types of core materials and their figures of merit are presented

**M**AGNETIC AMPLIFIERS are beginning to replace electron tubes in high-speed digital computers. The Ferractor, a magnetic amplifier capable of operating at frequencies as high as 2.5 mc, represents an increase in power-gain bandwidth product an order of magnitude over that previously considered practical with magnetic circuitry.

## Complementing Amplifier

Figure 1A shows the basic magnetic-amplifier circuit used. This circuit is similar to one proposed for lower frequency operation. Operation is divided into two separate periods by the carrier or power pulses applied to terminal 3. The positive half of the power pulse is the output period during which rectifier  $D_1$  can conduct and an output occur. During the negative

part of the carrier voltage,  $D_1$  is biased in the reverse direction, presenting a high impedance so the load is effectively disconnected from the core. This is the input period.

During this period, an input can occur without transferring energy by transformer action to the output circuit. The core material has a rectangular hysteresis loop and the volt-second characteristic of the positive half of the power pulse is adjusted to switch the core from  $-B_r$  to  $+B_r$  during the output period with input grounded. The power pulse then operates the core from  $+B_r$  to  $+B_r$  over a low-impedance portion of the hysteresis loop and substantial output results.

If, during the input period, a positive pulse is applied to terminal 1 that switches the core from  $+B_r$  to  $-B_r$ , then at the

start of the succeeding half-pulse period the power pulse will find the core at  $-B_r$ , and will just succeed in switching the core to  $+B_r$ , during this half-pulse period. The core will traverse a high-impedance portion of the hysteresis loop and low output will result.

Time relations are shown in the voltage waveforms of Fig. 1. This is a complementing amplifier. It will produce an output when no input is received and no output in the event of an input. An input signal is followed by an output period in which there is no output. Then there are two input periods during which there is no input, each one followed by the corresponding output. Finally, another input is followed by an output period with zero output.

The combination of  $D_3$ ,  $R_2$  and  $-V$  shown is a constant-current



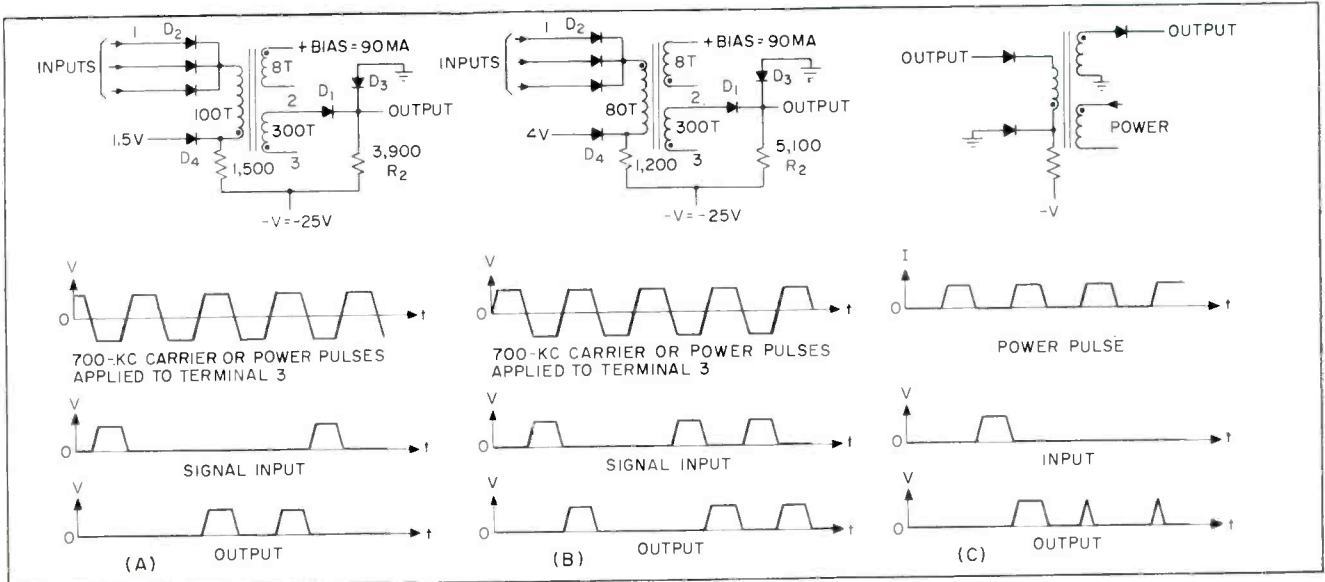

FIG. 1—Series magnetic complementing amplifier (A), series magnetic pulse amplifier (B) and parallel magnetic amplifier (C)

# HAS HIGH SPEED

sink capable of absorbing the no-output current of the amplifier. The current which flows in  $R_2$  is just equal to this no-output current. During a no-output period that current will be supplied through  $D_1$  instead of  $D_3$ .

The complete suppression of the no-output signal makes it possible to interconnect a large number of these amplifiers without danger of small or partial outputs growing into a full output. Furthermore, this circuit makes it possible for the carrier to impress across the core a fixed quantity of volt-seconds independent of the load. This is important in computer circuits where the load varies under logical-condition combinations.

Another constant-current circuit consists of  $D_4$ ,  $R_1$  and  $-V$ . This circuit limits the amount of current which can be transferred to the output by transformer action during a no-output period. Current limiting by this circuit is also necessary in the common situation where one amplifier drives a number of others that have parallel input circuits. Should one of the driven amplifiers saturate before the others, it will short-circuit the

source and prevent the amplifiers in parallel with it from switching. Current in  $R_1$  is set to be approximately equal to the magnetizing current of the core as seen from the input winding.

## Diode Enhancement

A major factor limiting the gain of the amplifier is the enhancement of rectifier  $D_1$ . Enhancement is the temporarily lowered back resistance of the diode which occurs immediately after a large forward current is carried and is caused by

the holes injected during the current-carrying period. As an example consider two point-contact diodes with identical d-c characteristics. Both might pass 20 microamperes at 20 volts reverse voltage. Exciting them by a 1-megacycle square wave to carry 100-ma forward current for  $\frac{1}{2}$   $\mu$ sec and then switching to the reverse direction for the succeeding  $\frac{1}{2}$   $\mu$ sec produces an average current flow during the negative half period of  $\frac{1}{2}$  ma for low-enhancement diodes and 5 ma for high-enhancement diodes.

The power gain of the magnetic amplifier cannot exceed the ratio of the forward to the back current of the output diode at operating frequency, voltage and current. In the circuit shown in Fig. 1A, the enhancement switches the core from the  $+B_c$  position at the end of the output period down the hysteresis loop toward  $-B_c$ , even if no input has been received. This switching might result in complete or partial cancellation of the following output pulse.

The effects of enhancement are counteracted by the bias winding. Constant direct current flows through this winding to overcome

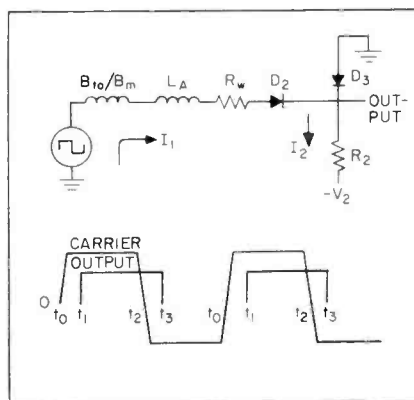
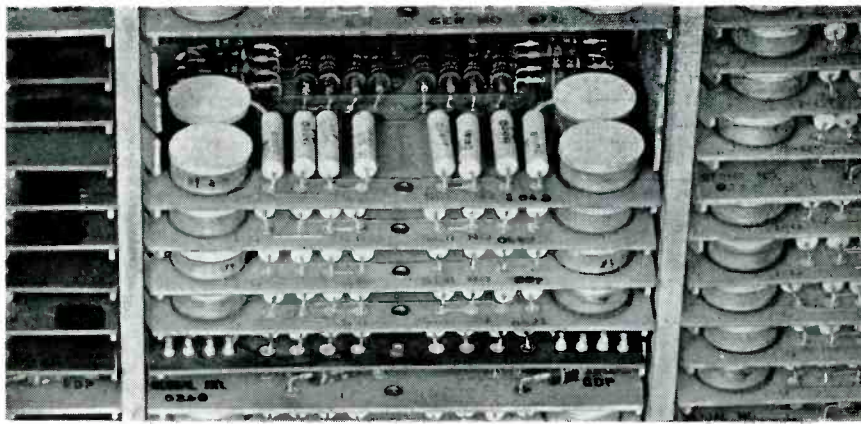

FIG. 2—Equivalent circuit of the series amplifier, including output waveforms. Circuit is used to calculate power gain



Printed circuit boards slide into card library as shown, providing compact construction

Table I—Power Gain of Series Magnetic Amplifiers

Freq	Core Gain	Gain with 5% Tolerance
100kc	150	45
250kc	75	20
500kc	42	10
1mc	23	6
2.5mc	10	3

the effects of enhancement and set the core back toward  $+B_r$ . The winding ampere-turns are equal in magnitude to the worst enhancement ampere-turns to be expected. Bias windings of a number of amplifiers are connected in series in the computer.

#### Basic Amplifier Circuit

One widely used variation of this circuit is shown in Fig. 1B. This is a series-magnetic noncomplementing or assertive amplifier. A cluster of input diodes used for computing purposes is shown. This circuit uses the same type of power pulses as the circuit shown in Fig. 1A and also makes use of a rectangular-loop magnetic material. However, in this circuit the bias winding and input winding serve different purposes.

The bias winding operates the core to  $-B_r$ . Therefore, in the absence of a signal no output will be received. The input overcomes

the effect of the bias and keeps the core at  $+B_r$ . Therefore, if an input is received during the following power period, the core is in a low-impedance position and high output results.

Recently a circuit similar to the parallel magnetic amplifier shown in Fig. 1C has been developed.<sup>2</sup> In this circuit, the power is delivered from a constant-current power source and the output is inductively coupled to the power source through the core. An input places the core on a high-impedance portion of the loop and an output results during the following half period. If no input is received, the core operates from  $+B_r$  to  $+B_r$ , and the output is a spike as shown in the waveform. Speeds up to several hundred kilocycles have been reported with this type of amplifier.

In the Ferractor type of circuitry, the no-output signal is easily suppressed by a constant-

current sink on the output. A single power source suffices for all 1,500 cores of the computer and this source provides 375 watts of pulse power at 660 kc.

The usual way to drive the constant-carrier circuits is to place a number of power windings in series in the plate circuit of a pentode. This requires approximately 100 pulse sources capable of 375 ma output current, with a total pulse power output of 1,500 watts. The larger amount of power is required because advantage cannot be taken of the load-sharing property of the circuits when using multiple clock sources.

Although the figures show rectangular waveforms, work is being done on sine-wave circuitry. A 2.5-mc demonstration unit uses sine waves for the clock-power waveform.

Since the power pulse divides the operation of the amplifier into two separate periods, it is convenient

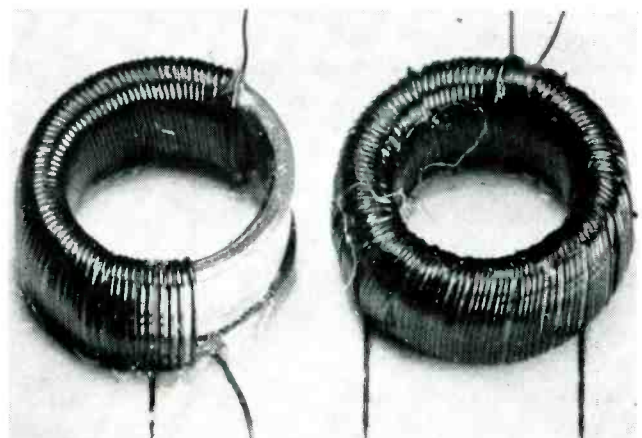
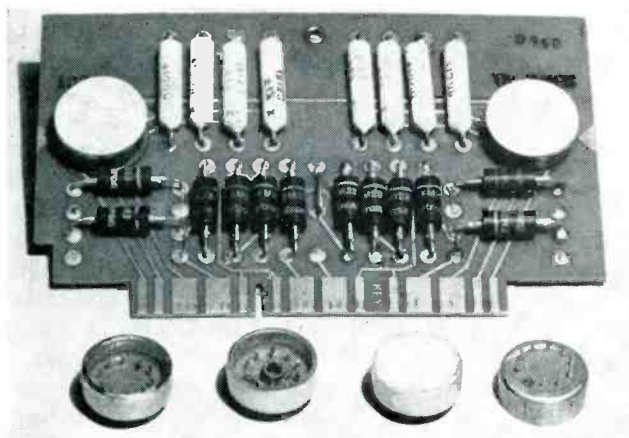

Typical printed circuit board (left) gives relative Ferractor size. Headers in various stages of construction are shown in foreground. Close-up (right) shows uniformity of windings obtainable with 0.1-inch-diameter cores using No. 45 wire



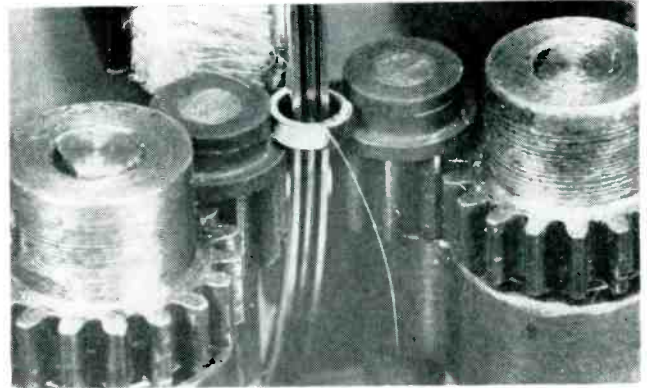
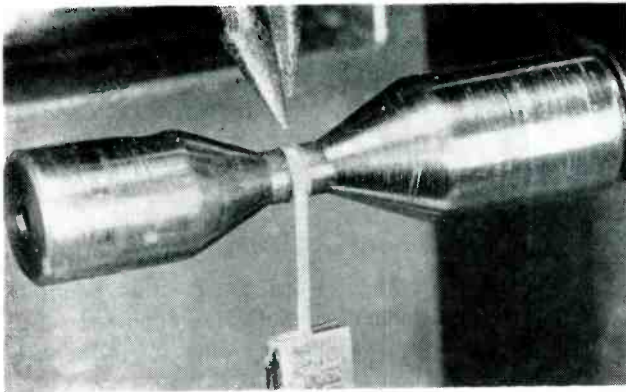

Method of winding 1/8-mil, 1/32-inch-wide tape on 0.1-inch bobbins (left). Weight provides tension during winding. Electrodes at top spot-weld tape to bobbin at start and during finishing operations. Bobbins in toroidal winding machine (right) have output winding, in which inductance is critical, put on first. Typical core has 12 wraps of tape on 150-mil diameter bobbin

to calculate the output and input powers separately, then take the ratio to obtain the power gain. Sufficient input power is required to effect the flux change that occurs in the core due to input signal and also to overcome any d-c biases that may be operating on the core. The input voltage is readily obtained from the assumed path on the  $B$ - $H$  loop during the input period. The switching current is obtained from the measured characteristics of the core.<sup>3</sup>

#### Output Power

To calculate output power the equivalent circuit shown in Fig. 2 is used. The quantity  $B_{t_0}/B_m$  is a fictitious inductance representing the flux change the core undergoes when starting from flux at  $t_0$  and increasing to the maximum flux during the output period, and  $B_{t_0}$  is the flux existing at the start of the output period. The maximum flux is close to the saturation flux density.

The inductance  $L_A$  represents the air-core inductance of the output winding, while  $R_w$  is d-c resistance and  $R_2$  the output diode. The two inductances absorb volt-seconds from the start of the output wave. This is approximately equivalent to delaying the start of the output voltage from  $t_0$  to  $t_1$ . Some of the energy lost during this period is recovered during the period between  $t_2$  and  $t_3$  but it is useless at this time since the input period of the next amplifier is over.

The drops in  $R_w$  and  $D_2$  decrease the output voltage amplitude. The principal conclusion to be drawn

is that in a practical situation at high frequencies the loss in power gain resulting from the delay between  $t_0$  and  $t_1$  more seriously decreases the power gain than does the decrease in amplitude resulting from the drops in  $R_w$  and  $D_2$ .

Table I shows the maximum power gain at several different frequencies of the series magnetic amplifier with a 15-volt power pulse, 120 ma maximum output current and a single-level logic circuit. The core gain column shows the gain limited by the  $B_r/B_m$  ratio of the core and the inductance of the output winding, while the second column shows the gain with reasonable tolerances on all components and voltages and with commercial diodes.

A power gain of three at 2.5 mc can be obtained. This is comparable to the best that can be achieved with the high-frequency transistors commercially available at present.

#### Systems Considerations

Digital data-handling systems require two carrier waveforms of the same frequency and amplitude but 180 degrees out of phase. The output period of the first-phase corresponds to the input period of the second phase and vice versa. Both power pulses can be obtained from a single output transformer with push-pull output windings.

Because of the low-impedance level, it is possible to use a large quantity of distributed wiring ca-

Table II—Figure of Merit for Various Core Materials

Material	Size	60-Cycle B-H Data				Dynamic Magnetizing Force					Merit Figure
		$B_s$ Gauss	$B_m$ $B_s$	$B_r$ $B_s$	$H_c$ Oersteds	Current Flip				Voltage Flip	
						1/4 $\mu$ s	1/2 $\mu$ s	1 $\mu$ s	2 $\mu$ s	1/2 $\mu$ s	
S-1	0.051D	1,880	0.90	0.86	1.48	3.62	2.55	1.81	....	4.36	203
S-3	0.051D	2,040	0.90	0.78	0.59	3.61	2.42	1.58	1.14	3.50	198
4-79 Permalloy	1/8mil	8,300	0.90	0.81	0.14	0.62	0.96	0.58	0.35	1.06	2,160
4-79 Permalloy	1/4mil	8,450	0.90	0.72	0.17	2.43	1.21	0.66	....	1.68	1,440
Orthonik	1/8mil	14,900	0.90	0.85	0.76	....	3.84	....	....	....	1,040
Supermalloy	1/8mil	8,030	0.90	0.76	0.10	....	1.11	....	....	....	1,620
Moly- perminvar	1/8mil	16,000	0.90	0.86	0.40	....	3.49	....	....	....	1,260
74.8 Permalloy	1/8mil	9,720	0.90	0.75	0.24	....	1.33	....	....	....	1,610



Packaging of Ferractor headers and other circuit components. Header at left shows how two cores, representing independent amplifiers, fit into hermetically sealed unit

capacitance. In the Univac magnetic computer, over 300  $\mu\mu\text{f}$  of capacitance are allowed on the output and 40  $\mu\mu\text{f}$  on the input of a magnetic amplifier with a negligible decrease in gain. Since the magnetic amplifiers respond to the integral of the signals applied to them over the input period and output period, they are insensitive to noise and ringing on input signals and power pulses. The combination  $D_s$  and  $R_s$  in Fig. 1A and Fig. 1B serves also to act as a current bias threshold analogous to the grid bias threshold used in electron-tube circuitry to suppress noise.

In the construction of a large system, design procedures are standardized as much as possible. A standard unit of maximum output power is fixed, based on that conveniently handled by the germanium diode. This unit may be on the order of 125 ma and 15 volts, representing the maximum allowable output load on an amplifier with a single output diode. A standard amplifier and complementing amplifier are then designed to yield maximum gain for this maximum output.

Where a larger number of drives is required, a double-power core is used. The double-power cores have twice the output of the single-power cores but require less than twice the input power of a single-power core.

### Core Material

Successful operation of the magnetic amplifier circuits depends in part on the use of optimal material and core design. The figure of merit for the core and magnetic material is

$$0.185 \frac{B_s}{H_m} \left( 2 \frac{B_r}{B_s} + \frac{B_m}{B_s} - 1 \right)^2 \frac{A_m}{A_w}$$

Figure of merit is defined as the

power gain of a series magnetic amplifier with ideal diodes, zero resistance in the output windings and all voltages, currents and resistors on value with zero tolerances. In this equation the effects of the material can be separated from those of the winding. The figure of merit is proportional to the saturation  $B$  dividend by  $H_m$ , where  $H_m$  is the  $H$  required to switch the core at the given speed of operation. Evaluation of the terms that contain  $B_r/B_s$  and  $B_m/B_s$  shows that power gain is roughly proportional to  $B_r/B_s$ . These terms account for the effects of the material. The figure of merit is directly proportional to  $A_m$ , the area of the magnetic material, divided by  $A_w$ , the area of the winding.

### Material Choice

To choose the best material, all commercially available alloys and ferrites were tested and a number of specially prepared ferrites and alloys were checked. Table II shows a comparison of some of the more promising materials. Note that  $\frac{1}{8}$ -mil 4-79 molybdenum Permalloy has the highest figure of merit when evaluated for  $\frac{1}{2}$ -microsecond pulses.<sup>4</sup> This figure of merit assumes unity for  $A_m/A_w$ . In fact,  $\frac{1}{8}$ -mil 4-79 molybdenum Permalloy has the lowest  $H_m$  of any material tested for switching time between one  $\mu\text{sec}$  and 0.1  $\mu\text{sec}$ . Furthermore, it has the highest value of  $B_s/H_m$  of any material tested. The high  $B_s/H_m$  more than compensates for the low  $B_r/B_s$ . The low value of  $B_r/H_m$  was expected in evaluating ferrites for memory use.

The quantity  $B_s$  is an intrinsic property of the material, while  $B_r$  is the remanence when the core is switched over a hysteresis loop of a type that  $B_m/B_s$  equals 0.9. This ratio corresponds closely to normal

amplifier operation.

The values of the figures of merit are for the core material only and do not include the factor  $A_m/A_w$ . However, when these factors are entered the relative status is not altered.

### Bobbin Design

The  $\frac{1}{8}$ -mil 4-79 molybdenum Permalloy must be supported on a bobbin during annealing and subsequent winding because it is extremely fragile and sensitive to strain. Because of the great dependence of the figure of merit on the ratio of the material cross-section to the winding cross-section, an attempt was made to make the bobbin walls as thin as possible. It was soon found that when the wall of the ceramic bobbin was made less than approximately 10 to 15 mils thick, the bobbins became extremely fragile.

Instead of the relatively bulky ceramic bobbin, a metal bobbin was used to support the  $\frac{1}{8}$ -mil Permalloy. Metal bobbins can readily be made with walls only three or four mils thick and still have sufficient strength to withstand the annealing cycle and subsequent winding.

At a frequency of 1 mc, the power-gain bandwidth achieved by use of the stainless steel bobbin is about four times that of the optimal ceramic bobbin. Since the power gains obtained at 1 mc are on the order of five to seven, the stainless steel bobbin makes magnetic amplifier circuits for computers operating at this frequency practical.

This work was supported in part by the AF Cambridge Research Center under Contracts AF 30 (602)-1055 and AF 19 (604)-1376. The contributions of J. P. Eckert, Jr. and Robert D. Torrey are gratefully acknowledged.

### REFERENCES

- (1) R. A. Ramey, On the Mechanics of Magnetic Amplifier Operation, Paper 51-217, *Trans AIEE* 70, p 1,214, 1951.
- (2) D. Leov, W. Miehle, J. Paivinen and J. Wylen, Magnetic Core Circuits for Digital Data Processing Systems, *Proc IRE*, 44, p 154, Feb. 1956.
- (3) N. Menyuk and J. B. Goodenough, Magnetic Materials for Digital Computer Components, I. A Theory of Flux Reversal in Polycrystalline Ferromagnetics, *Jour App Phys*, 26, p 8, Jan. 1955.
- (4) M. F. Littmann, Ultrathin Magnetic Alloy Tapes with Rectangular Hysteresis Loops, *Elec Eng*, 71, p 792, Sept. 1952.



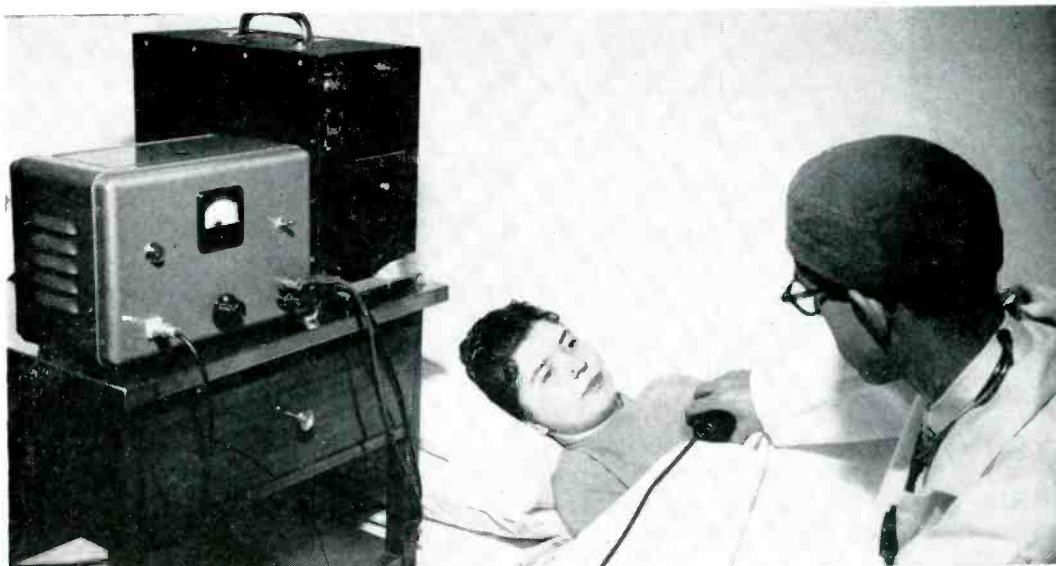

Compact transistorized heartbeat recording system can be operated from either battery or a-c line

# Transistor Amplifier for Medical Recording

By D. W. R. McKINLEY and R. S. RICHARDS

National Research Council  
Ottawa, Canada

**SUMMARY** — Pen recorder amplifier provides transformerless system for recording 3-cps heart signals. Modification of feedback circuit gives audio amplifier with up to 5-watt output flat within 0.2 db from 20 cps to 20 kc

**R**ESearch work in medical electronics often requires an amplifier to couple a heart-beat microphone to a pen recorder. Microphone output is 1 mv at 10,000 ohms and required frequency response of the amplifier is 3 db down at 3 cps and 2 kc. Recorder input impedance is 17 ohms, with 4 volts needed for full-scale deflection.

These impedances, power levels and frequencies suggest the application of transistors and a complementary-symmetry in the output stage to avoid an output transformer. The amplifier shown in Fig. 1 met these performance specifications satisfactorily. With slight modifications, it has also been used as an audio amplifier to feed a loud-

speaker at a level of 1 or 2 watts, with low distortion and flat response to 20 kc.

## Recorder Amplifier

The overall voltage gain of the amplifier is about 4,000 with the feedback loop. The minimum input impedance is about 10,000 ohms and 1 mv produces 4 volts rms output across a 10-ohm load, hence the overall power gain is approximately 100 db. Direct-current feedback loops in the preamplifier stages ensure a high degree of temperature stabilization. Emitter degeneration is employed in the first stage to raise the input impedance to the desired level.

The driver-output stages have

100-percent internal voltage feedback, with slightly less than unity voltage gain, but there is still a trace of crossover distortion unless the feedback loop to the base of the last preamplifier transistor is in place. Degeneration introduced by this loop is 16 db. The 220- $\mu$ f bypass capacitor across the 22,000-ohm resistor in this loop is essential when working with a purely resistive load, otherwise high-frequency transients can cause the power transistors to run away.

The solid curve in Fig. 2, shows the frequency response curve of the amplifier working into a 15-ohm resistive load, with feedback network A. The 3-db points are at 2 cps and 9 kc. The slight increase in

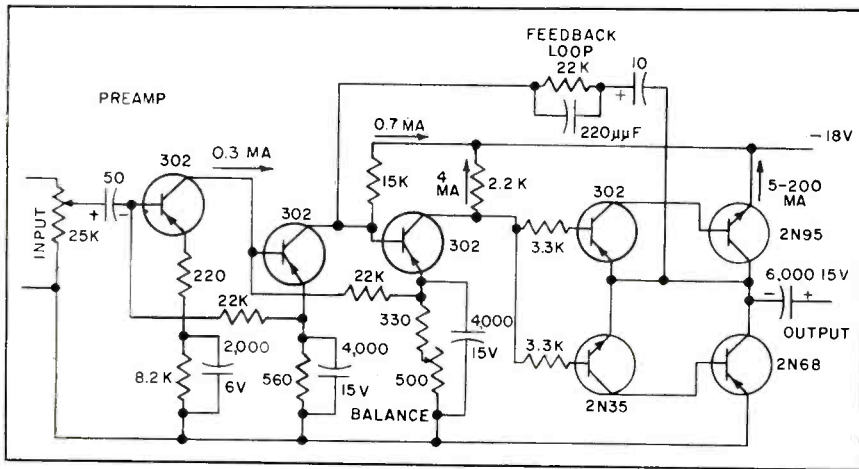

FIG. 1—Transformerless amplifier uses complementary symmetry output stage to match 15-ohm load input impedance of cardiograph pen recorder

response at 5 cps can be removed by selection of the series feedback capacitor and the emitter bypass capacitor, but in practice this bass boost compensates for the fall-off in microphone response at these frequencies.

Figure 3A shows the performance of the amplifier as the load resistance is varied. The maximum undistorted output (1-kc sine wave just below clipping level) is about 1 watt for a 30-ohm load and 2.5 watts for a 6-ohm load.

The efficiency is defined as the ratio of a-c output power to the product of the d-c supply voltage and current to the combined driver-output stage. Curves of total rms harmonic distortion are shown in Fig. 3B for constant output levels of 0.5, 1 and 2 watts.

In Fig. 3C, the solid curve shows the total rms harmonic distortion; and the dashed curve shows the intermodulation distortion, as the input power level is varied. The output signal power, measured here across a 15-ohm load, is directly proportional to input power up to the clipping level. Once this level is reached the distortion increases rapidly.

### Clipping

Operating level of the amplifier should be set so clipping does not occur on the peaks when using a loudspeaker load. The pen recorder is an effective peak limiter. Since the undistorted voltage swing of the amplifier is well in excess of the recorder range, harmonic distortion is no problem with the re-

coder. At reasonable operating levels the harmonic distortion is less than 0.5 percent and the intermodulation distortion still smaller, which meets the requirements of a fairly good audio amplifier.

### Noise

With a source impedance of 10,000 ohms and an assumed effective bandwidth of 10 kc (using network A of Fig. 2) the measured noise output at full gain is 12 millivolts, which is 52 db below the maximum rms signal voltage of 5.2 volts across a 15-ohm load. This is quite satisfactory since the dynamic range of the recorder is less than 40 db. Noise factor of the amplifier is about 7 db. If low-frequency response is not required the noise factor might be improved by redesigning the first stage to eliminate the electrolytic condensers, and by using a low-noise transistor.

The 500-ohm balance control in Fig. 1 is adjusted initially to bring the collector potential of the last preamplifier stage to half the supply voltage. Alternatively, it may be set so a strong sine-wave signal

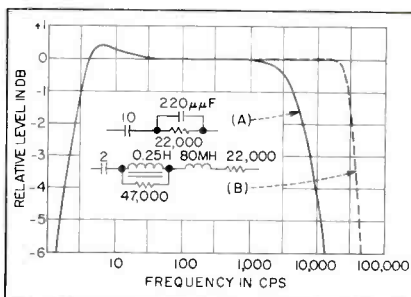

FIG. 2—Response curves of transistor amplifier using two feedback networks

input is clipped equally on positive and negative peaks at the output. Once set, it needs no further attention since the d-c feedback maintains a constant current in this stage over a wide temperature range.

No special selection of transistors is necessary, even for the push-pull driver and output stages, provided that the current gains are within the range of tolerance specified by the manufacturers. The 6,000-µf electrolytic capacitor coupling the output to the load may be omitted by returning the load to a center tap on the power supply. This center tap has to be a low impedance point, which can be obtained easily when using batteries. If a-c operation is desired, two power supplies of opposite polarity are needed to obtain the necessary low impedance.

Direct coupling of the load requires careful selection of the output transistors to ensure equal collector currents, with zero d-c in the load. Even with the best available pair of transistors a small d-c unbalance was observed with increasing output amplitude, resulting in a few milliamperes shift in the load current.

### Loudspeaker Amplifier

The only essential change required in the circuit of Fig. 1, to make it useful for driving a loudspeaker, is to modify the feedback loop as shown at (B) in Fig. 2. In this network the distributed capacitance of the 0.25-henry choke was excessive, so the 80-millihenry air-core choke was added in series to reduce feedback at the highest frequencies.

The frequency response of the amplifier driving a 15-ohm loudspeaker is shown as the dashed curve in Fig. 2. It is flat to  $\pm 0.2$  db from 20 cps to 20 kc, falling off 3 db at 30 kc. Low-frequency response is less important in this application therefore the values of coupling and bypass capacitors may be reduced by a factor of 10 or so, to bring the lower 3 db point up to about 20 cps. The amplifier will also drive a 7-ohm speaker quite satisfactorily, at levels up to 2.5 watts.

The amplifier is well suited to



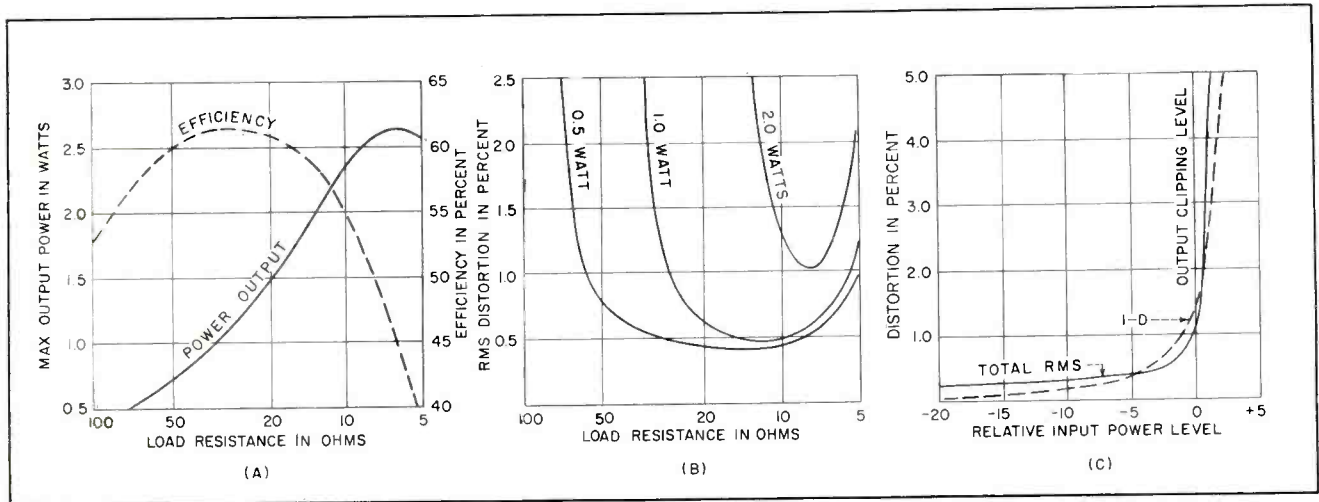

FIG. 3—Power and efficiency (A) rms distortion (B), and rms and intermodulation distortion compared to input power level (C) for transformerless transistor amplifier used to record heart signals at frequencies down to 3 cps

portable operation, using three 6-volt batteries. Over one watt output with 0.5-percent distortion can be supplied to a 15-ohm speaker, with excellent battery economy. Under these conditions the normal overall idling current to all stages is 10 to 15 ma, which increases to 165 ma on peaks. With a 7-ohm loudspeaker the peak current is about 280 ma for 2.5-watts output.

The output transistors work well below their normal ratings and power outputs up to 4 or 5 watts can be obtained by increasing the supply voltage. At still higher levels, the driver stage is the limiting factor, as these transistors can no longer supply adequate base currents to the output transistors.

The 302-2N35 drivers can be replaced by a pair with higher ratings, such as a 2N68-TN95 pair, to yield 10 watts or more of output power on peaks. However, the input impedance of the 2N68-2N95 drivers is considerably lower than that of the 302-2N35 pair, which necessitates a redesign of the previous stage. Furthermore, with the same supply voltage, the idling current of the modified power stages is increased four or five times over the idling current of the original circuit, which may be a serious drawback with battery operation.

### Power Supplies

Because of the class-B operation, batteries will give good service in portable applications. Where 110-volt 60-cycle power is readily available, the simplest forms of tran-

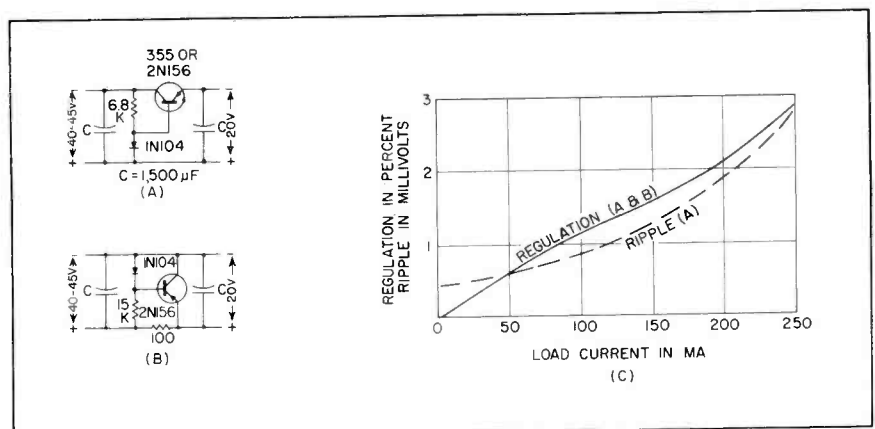

FIG. 4—Series (A) and shunt (B) regulators provide regulation (C) for a-c operation

sistor-regulated power supply are very satisfactory, since the main function of the regulating action is to suppress the ripple voltage. A conventional transformer-rectifier supply, with silicon diodes, is used to furnish full-wave rectified power at 40 to 45 volts to the regulators shown in Fig. 4.

### Series Regulation

With constant load the output voltage of the series regulator, Fig. 4A changes by 1 percent as the line voltage is varied from 90 to 130 volts. Output voltage variation is 2 percent for a load change of 0 to 200 ma. Maximum ripple voltage is reduced to about 2 mv in 20 volts, as compared to 150 mv in 20 volts for the same power supply and filter without the transistor. Ripple voltage of the series regulator decreases as the load drops. The output voltage is fixed at slightly less than the breakdown voltage of the

Zener diode, 1N104, which is pre-selected in the desired voltage range.

The shunt arrangement of the same transistor and diode, shown in Fig. 4B, has a load regulation curve that is almost identical to that shown for the series regulator. The output voltage now is slightly greater than the voltage across the Zener diode. The ripple voltage remains constant at about 2 mv, independent of load. The shunt-regulated supply is a constant-power device, and the total power consumed, including the loss in the 100-ohm series resistor, is greater than for the series regulator, except when the latter is operated continually at maximum load current. On the other hand, an accidental short-circuit across the output of the shunt regulator does no harm, whereas a short across a series regulator usually destroys the transistor.

**SUMMARY** — New type of crossed-field microwave tube resembles magnetron but has no resonant circuit. Operating frequency is determined externally, either as broadband amplifier or frequency-stabilized self-excited oscillator giving over 60-percent efficiency at output of 2 megawatts. In amplifier operation, radar beam can be scanned without mechanically moving reflector or radar can be shifted rapidly to new frequency to avoid r-f interference or enemy jamming signals

By **WILLIAM C. BROWN**

Raytheon Manufacturing Co.  
Waltham, Mass.

# Platinotron Increases

**T**HE PLATINOTRON is a new microwave tube which combines high power output, high efficiency, broadband amplification, low d-c input impedance level, low pushing figure and simple, compact mechanical construction. Power output in the L band is nearly 2 megawatts with over 60-percent efficiency at this level. A bandwidth of 10 percent is easily achieved without dropping below 50 percent in efficiency.

The platinotron derives its high power and efficiency from the magnetron principle of interaction. The bulk of the d-c energy delivered by

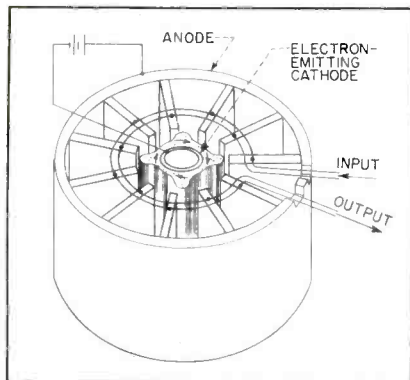

**FIG. 1**—Mode of operation of platinotron is complex, utilizing crossed electric and magnetic fields and a recirculating stream electron beam to give backward-wave behavior

the power supply is converted directly into r-f energy. In addition to having many of the desirable properties of the conventional magnetron oscillator, the new tube has an entirely new and highly desirable performance characteristic—broadband amplification. The chief physical difference from a conventional magnetron is the use of two external couplings for transmission lines rather than one.

### How It Works

The mode of operation is shown in Fig. 1. First an r-f signal is injected into the device. This traverses the r-f circuit and proceeds to the output with little loss because the insertion loss is kept low, usually below 0.5 db. A d-c potential is then placed between the cathode and anode as indicated. As the potential is raised, a cloud of electrons forms around the cathode in the shape of a concentric ring and rotates with an angular velocity dependent upon the applied potential.

As the potential is further increased, a critical value is finally reached where the angular velocity of the outermost electrons becomes synchronous with the velocity of a wave traveling on the circuit. At that point the ring transforms into

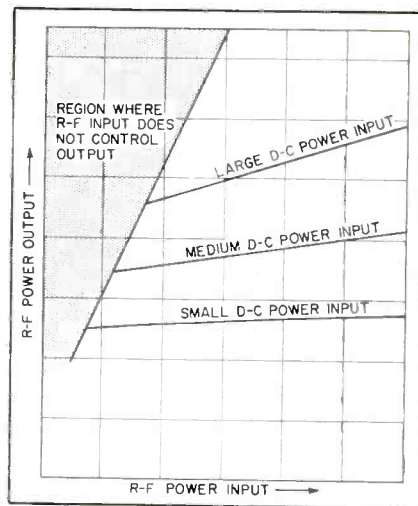
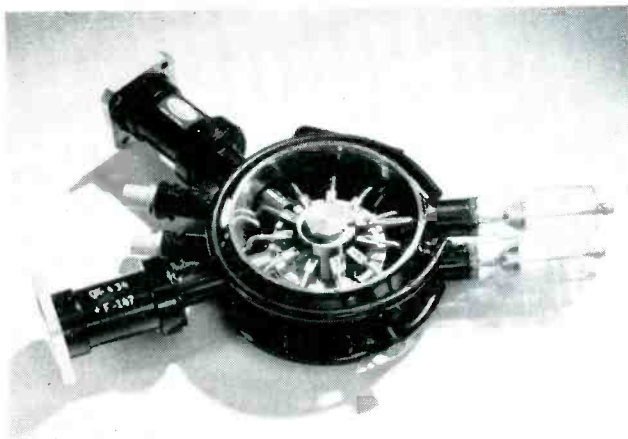

**FIG. 2**—Power output increases only slightly with r-f power input, but increases rapidly with d-c power input

a hub with spokes of space charge or electrons projecting from it. The electrons in these spokes deliver energy to the r-f circuit, surrendering their potential energy (which is a maximum when they are at the cathode) to the r-f field as they move radially to the anode and are collected. Interaction between the spokes of electrons and the energy traveling on the circuit can occur over a wide band of frequencies, without any adjustment of the tube.

As voltage is increased, electrons





**FRONT COVER**—Basic platinotron, with magnet and one cover removed to show 11-vane construction surrounding central 0.75-inch-diameter cathode. Glass-insulated heater leads are at right

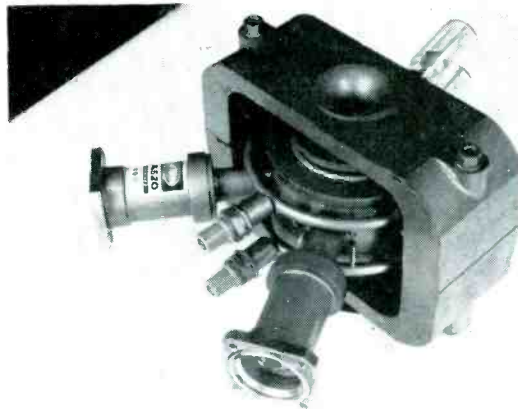

Typical permanent magnet construction. Unlike magnetron, new tube has two external couplings instead of one, with vacuum fittings located between input and output

# Search Radar Range

in the spokes move more rapidly to the anode and create more current flow. The angular velocity remains the same.

## Amplifier Operation

The platinotron behaves as a saturated amplifier rather than as a linear amplifier. The magnitude of the r-f output is independent of r-f input but dependent on d-c input. If the r-f drive for a given level of d-c input is reduced to too low a value, the device ceases to be an amplifier.

Applications of the device are limited to those of a saturated amplifier. This is not a large restriction since pulsed radar applications use amplifiers under saturated conditions and most frequency-modulated devices can make use of a saturated amplifier.

Characteristics of the r-f output as a function of the r-f input are given in Fig. 2. The output does increase somewhat with r-f input, because efficiency increases slightly at higher r-f drive. Also, the r-f drive reappears unattenuated at the output and adds to the r-f power generated by the platinotron itself.

A test setup for amplifier operation is shown in Fig. 3. The resistive isolation pad reduces the out-

put power level from the platinotron oscillator to a suitable driving level and presents a reasonable match to any power which might flow in the reverse direction from the platinotron amplifier toward the input. If re-reflected rather than absorbed, this power would interfere with the measurements being made. In prac-

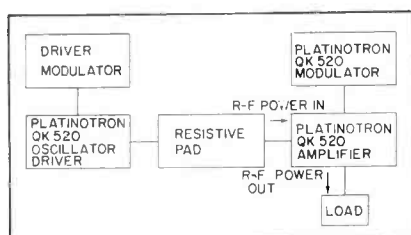

**FIG. 3**—Testing platinotron as amplifier

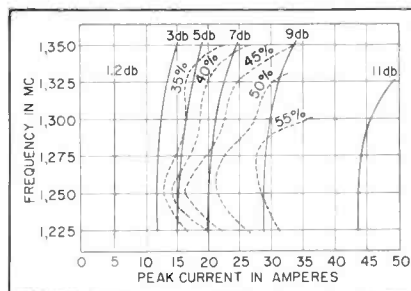

**FIG. 4**—Contours of constant gain and efficiency, obtained by feeding in a nearly theoretical 5-microsecond r-f input spectrum and varying such parameters as anode potential, anode current, magnetic field, frequency and load

tical applications a ferrite isolator with directional attenuation properties is used in place of resistive pad.

With a 5-microsecond input pulse, the output spectrum was observed at anode current increments of 5 amperes up to 50 amperes and frequency increments of 25 mc from 1,225 mc to 1,350 mc. At no point was there a degradation of the quality of the spectrum. Even at the higher current levels, the efficiency was well over 50 percent, with gain of about 10 db.

Efficiency is here defined conservatively as r-f power output minus r-f power input, divided by d-c power input. The test data is replotted in Fig. 4 to give contours of constant gain and efficiency.

The relationships between anode voltage, anode current, magnetic field and power output and efficiency are shown in Fig. 5. The magnetic field usually represents a compromise between magnet weight and the higher efficiency which can be obtained at higher values of magnetic field. Once the magnetic field is selected, it determines the relationship between anode voltage and current. The curves closely follow those for magnetrons.

Under variable load conditions

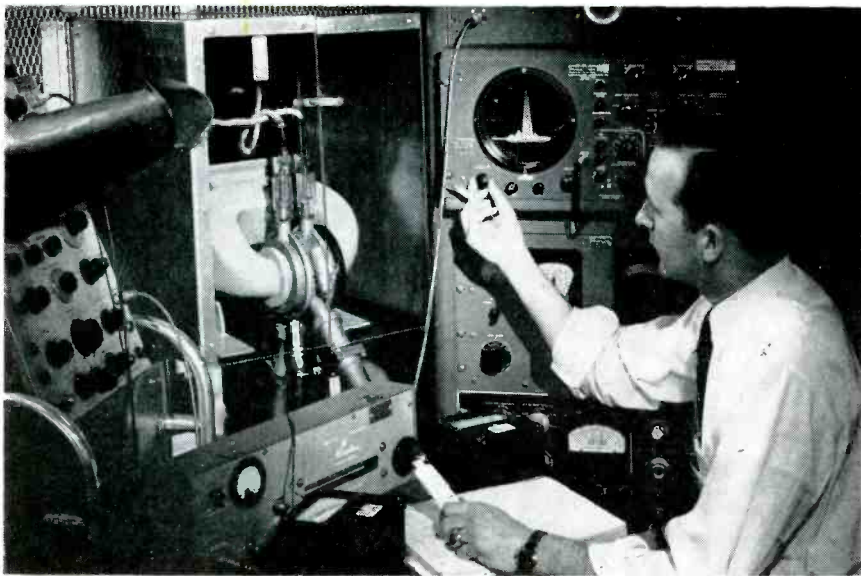

Test setup for amplifier operation of platinotron, with pulse output spectrum showing on screen of scope at right of tube

the quality of the output spectrum remains unperturbed regardless of phase position of output mismatch and vswr up to a value of 2.5.

### Oscillator Operation

The directional behavior and broadband characteristics of the platinotron make stabilized oscillator operation possible over a relatively broad band of frequencies without changing the tube in any way. Table I compares a platinotron oscillator with a comparable magnetron widely used in radar systems.

The method of using a platinotron in conjunction with other circuit elements to form a highly frequency stabilized oscillator is shown in Fig. 6. Where tuning is not required, the line stretcher is omitted. A portion of the output power is reflected from the reference plane  $ll'$ . This reflected power

travels back through the platinotron anode with little or no attenuation or reflection and out to reference plane  $rr'$ . Here most of it is again reflected, the phase of the reflection depending upon the frequency of the incident power and the resonant frequency of the stabilizing cavity. This re-reflected power is then amplified by the backward wave principle and arrives at the reference plane  $ll'$  at full output level.

Steady oscillations can occur only if the loop phase shift from plane  $ll'$  to plane  $rr'$  and return is an integral multiple of 360 degrees. The phase shift vs frequency characteristic of the stabilizing cavity has a slope many times greater than that of any other element in the circuit. A slight change in frequency will thus permit the cavity to correct for a substantial phase shift which might be introduced by

such factors as a change in the antenna load or frequency pushing of the electron stream.

The four phase-shift components which add up to give the total loop phase shift  $\theta_a$  of the system are shown in Fig. 7. Expressed in radians, these are  $\theta_1$ , the two-way phase shift along the coaxial transmission lines which connect planes  $ll'$  and  $rr'$  to the platinotron;  $\theta_2$ , the two-way phase shift which takes place in the platinotron itself;  $\theta_3$ , the phase shift which takes place at reference plane  $rr'$  of the stabilizing cavity system;  $\theta_4$ , the phase shift which appears at reference plane  $ll'$  of the output reflection.

The system will oscillate at a frequency where the total loop phase shift  $\theta_a$  is an integral multiple of  $2\pi$  radians. The phase shift vs frequency characteristic of the stabilizing cavity in the region of cavity resonance has a slope many times greater than that of any other element in the circuit. The tube oscillates in this region

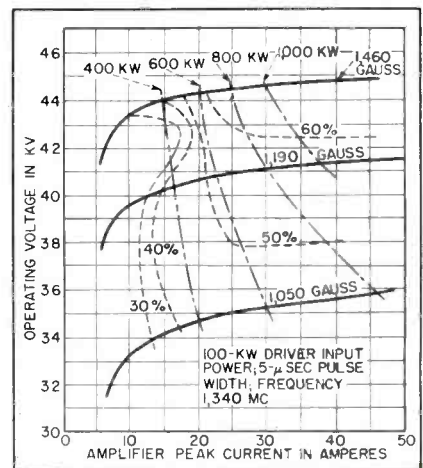

FIG. 5—Typical performance chart for L-band platinotron amplifier

Table I—Comparison of Characteristics as Oscillators

	5J26 Magnetron	QK520 Platinotron
Pulling Figure in mc per sec. . . . .	2.0-2.5	0.4-0.6
Pushing Figure in kc per sec per amp. . . . .	50-100	1-4
Peak Operating Current in amperes. . . . .	46	40
Operating Magnetic Field in gauss. . . . .	1,400	1,150
Operating Voltage in kv. . . . .	28.2	36.0
Typical Efficiency in per cent. . . . .	42	52
Peak Power Output in kw. . . . .	550	750
Spectrum Sensitivity to Heater Power. . . . .	Sensitive	Not Sensitive
Tuning Range in mc per sec. . . . .	1,220-1,350	1,260-1,350

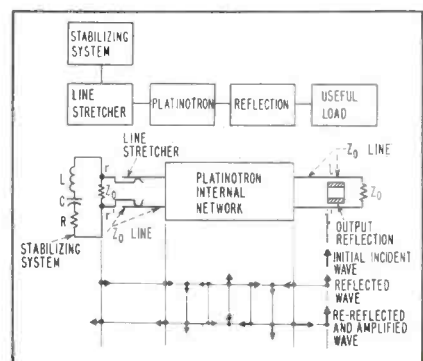

FIG. 6—Method of operating platinotron as frequency-stabilized oscillator



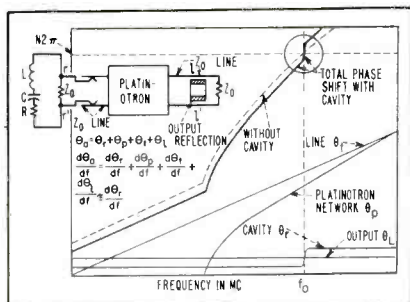

FIG. 7—Components contributing to total phase characteristic of stabilized oscillator. Intersection of dotted lines determines frequency of operation

of steep slope, corresponding to  $N2\pi$  loop phase shift, because damping resistor  $Z_0$  effectively absorbs all incident energy unless it be at a frequency close to that of the resonant frequency of the cavity. There is then no reflected signal for excitation of the platinotron at frequencies and loop phase shift corresponding to other integral multiples of  $2\pi$  radians.

### Oscillator Stability

It is the steep slope of the phase shift characteristic of the cavity which gives the system its high degree of frequency stability. The region of this steep slope is enlarged in Fig. 8. Any increment of phase shift  $\Delta\theta$  added to the total loop phase shift of the stabilized system changes the total value of the loop phase shift and causes the phase-shift curve to intersect the phase shift value  $N2\pi$ , required for oscillation of the system, at a different frequency.

The heavy dashed line in Fig. 8 represents the phase-shift characteristic of an unstabilized system before an incremental phase change  $\Delta\theta$  has been added. The light dashed line represents this same characteristic after the addition of the  $\Delta\theta$  increment. The change in operating frequency of the system caused by the  $\Delta\theta$  increment is seen to be  $\Delta f_u$ .

The heavy solid line represents the phase-shift characteristic of a stabilized system before  $\Delta\theta$  has been added, and the light solid line represents the same characteristic after the addition of  $\Delta\theta$ . In the stabilized case the resulting frequency change  $\Delta f_s$  caused by the  $\Delta\theta$  increment of phase is much less

than the frequency change  $\Delta f_u$  in the unstabilized case.

Assuming that the cavity is the only significant stabilizing element in the circuit, the degree of stabilization  $S$  is

$$S = \left( \frac{df}{d\theta_p} \right) \left( \frac{2Q_L}{f_0} \right) \quad (1)$$

where  $Q_L$  is the loaded  $Q$  of the cavity,  $f_0$  is the resonant frequency of the cavity and  $df/d\theta_p$  is the slope of the platinotron phase-shift characteristic.

The stabilization factor  $S$ , which may easily be in the range of 50 to 100, is the ratio of frequency stability in the cavity-stabilized platinotron to the frequency stability of the unstabilized platinotron run as an oscillator. This factor  $S$  also represents the improvement in frequency stability over a conventional unstabilized magnetron for those frequency instabilities associated with changes in the internal circuit, such as temperature change, vibration, deposition of material on vanes, electronic loading and barometric effects.

### Oscillator Efficiency

Large stabilizations can be obtained by relatively low values of loaded  $Q$  of the cavity. Since the unloaded  $Q$  of the cavity can be made at least 20 times as great, and

since the stabilizing cavity is placed at the input side of the platinotron and therefore has only a fraction of the output power incident upon it, the overall circuit efficiency can be held well over 95 percent.

Figure 9 gives the value of the

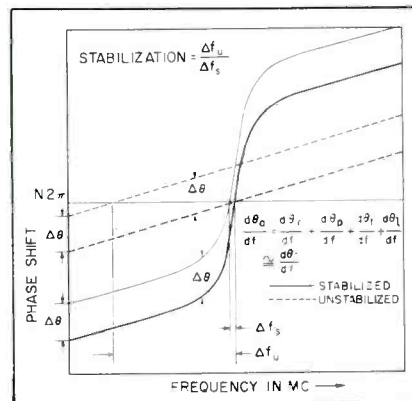

FIG. 8—Expansion of encircled area in Fig. 7, showing stabilizing action of cavity

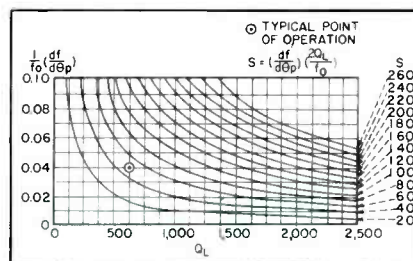
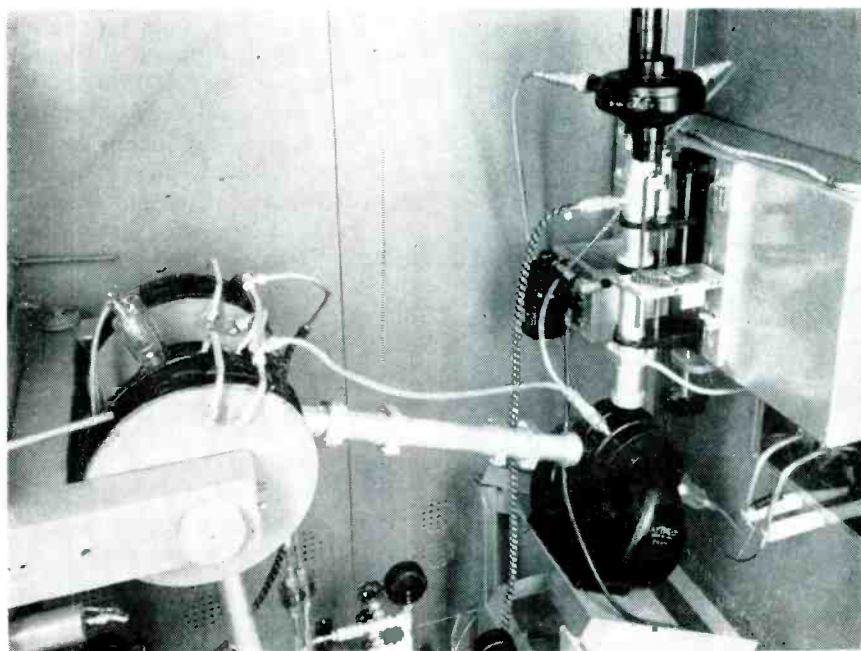

FIG. 9—Variation of stabilization factor  $S$  with  $Q$  of cavity and slope of platinotron phase-shift characteristic



Two platinotrons operating together, with oscillator at right and amplifier at left. All oscillator tuning is achieved by mechanical drives acting on external cavity

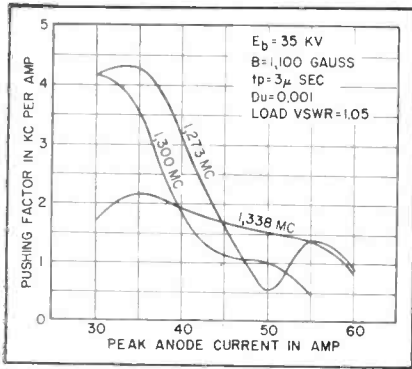

FIG. 10—Dynamic pushing characteristic of L-band stabilized oscillator as function of frequency and anode current. Stabilization factor  $S$  is approximately 70 here

stabilization factor  $S$  for various combinations of cavity-loaded  $Q$  and slope of the platinotron phase-shift characteristic.

### Pulling Figure

For a number of reasons  $|r_1|$  is usually chosen to be 0.6. Then a practical expression for the pulling figure, which is generally recognized as a measure of the effect which a change in external loading

has upon the frequency of the oscillator, is

$$\Delta f = 0.225 f_0 / Q_L \quad (2)$$

where  $f_0$  is the operating frequency of the system and  $Q_L$  is the loaded  $Q$  of the stabilizing cavity system. This equation gives pulling figures which represent a reduction of from 5 to 20 times those normally associated with magnetrons.

### Stabilization Factor

Effects of variations in anode current are reduced in the ratio of the stabilization factor  $S$ . The dynamic pushing figures that may be expected are shown in Fig. 10. The pushing figure is defined as the slope of the curve of frequency vs anode current. The drastic reduction in frequency pushing figure means that excellent spectra can be obtained, even with poorly shaped current pulses. Figure 11 compares frequency spectra resulting from a poorly shaped long-duration (17-microsecond) current pulse in an L-band platinotron oscillator and in a 5J26 L-band magnetron. With the platinotron a nearly theoretical spectrum is obtained, while for the 5J26 the spectrum is more than ten times theoretical.

### Discontinuities

With stabilized oscillator operation of the platinotron there are no regions of anode current or cathode temperature where the effect of the rotating electron beam on the circuit becomes partly or completely discontinuous, as is the case in magnetrons. Such discontinuities can be avoided by using magnetrons only for short-pulse-width applications. As longer pulse widths are used, it becomes increasingly difficult to avoid trouble from this source, which evidences itself by a discrete jump in frequency of the order of a fraction of a megacycle. Since the platinotron does not experience this phenomena, long pulse widths may be used and a broad range of cathode temperatures may be permitted without adversely affecting the near-theoretical quality of the spectrum.

### Oscillator Performance

Behavior over a 100-mc tuning range as an oscillator is shown in Fig. 12. Anode potential, efficiency and

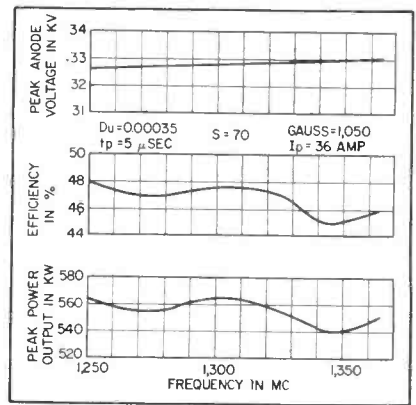

FIG. 12—Platinotron oscillator performance as function of frequency with matched load and fixed values of magnetic field and anode current

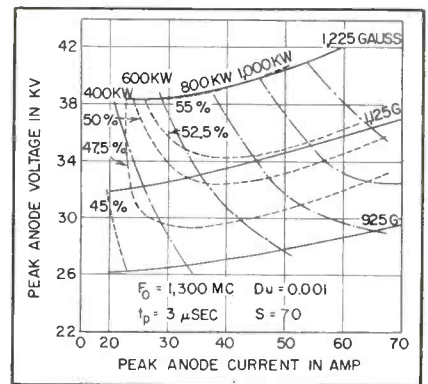

FIG. 13—Platinotron oscillator performance as function of anode current, anode setup and magnetic field at 1,300 mc

and power output vary only slightly over the 100-mc range.

Variation of peak power with anode current and magnetic field used is shown in Fig. 13. As the magnetic field level is increased, the anode potential must also be increased to maintain a constant value of anode current. As the magnetic field is increased, the efficiency first increases rapidly and then more slowly. In practice a magnetic field is selected which is the best compromise between efficiency of operation and size of magnet, which is usually a permanent magnet.

The power output that can be obtained depends primarily upon the life expectancy to be specified. Life at an operating point of 36 kv, 40 peak amperes and 0.0024 duty cycle is in excess of 500 hours.

The early and continued support of Evans Signal Laboratory in developing this tube for military use is gratefully acknowledged.

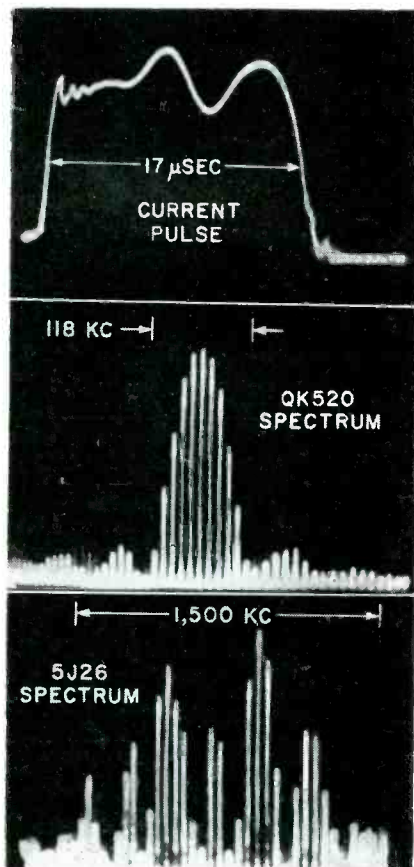

FIG. 11—Comparison of output spectra of QK520 platinotron and 5J26 magnetron for 17-microsecond current pulse



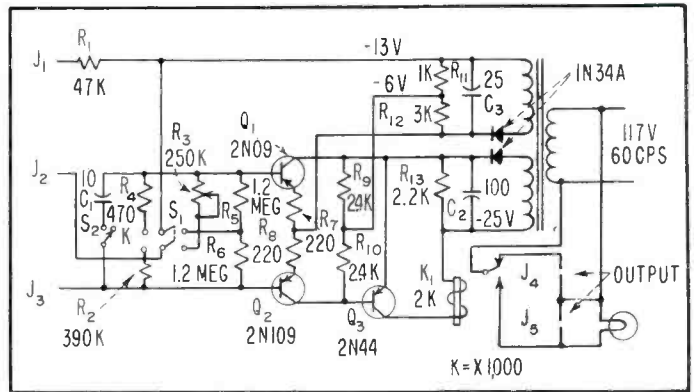
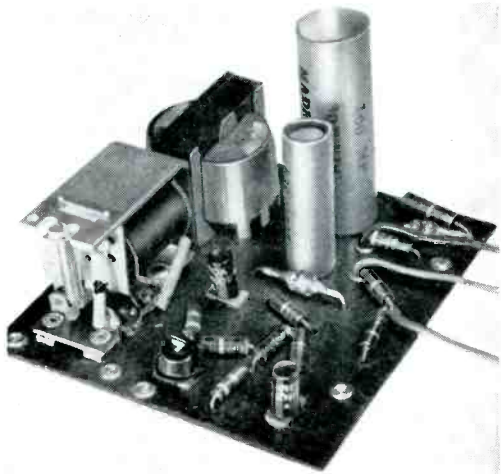

FIG. 1—Circuit diagram of the three-transistor control device

Equipment side of printed chassis

# Transistorized Lab Relay

**SUMMARY** — Control device with almost indefinite life operated from socket power is mounted on printed-circuit board. Semiconductor diodes and transistors permit miniaturization with size determined only by a-c output fixtures, transformer and relay. Controlled circuits can be normally on or off

**A**DVANTAGE of inherent long-life characteristics of transistors is exploited in the design of a new transistorized relay. Two matched 2N109 transistors are used in balanced input and one 2N44 in the relay coil circuit.

Balanced input compensates for ambient temperature changes; it also permits greater versatility in the control circuits. The relay can be energized by a normally open or normally closed contact, by illumination on a cadmium-sulfide cell or photocell and by a control current of 12 microamperes more or less. With the current input feature, a photovoltaic cell, for example, can be used to control the opening and closing of the relay.

The schematic circuit diagram is shown in Fig. 1. With  $S_1$  in normally open position and no input signal, the bias currents of  $Q_1$  and  $Q_2$  are equal. The voltage drops across  $R_9$  and  $R_{10}$  are also equal and opposite; therefore, the resultant voltage at the base of  $Q_3$  is zero.

If  $J_1$  and  $J_2$  are shorted with

By **HARRY A. GILL**

*Development Laboratories  
Fisher Scientific Co.  
Pittsburgh, Pa.*

a resistance up to 400,000 ohms, the increased bias on  $Q_1$  upsets the balance of voltage on  $R_9$  and  $R_{10}$ , producing a negative voltage at the base of  $Q_3$ . Sufficient collector current then flows through  $Q_3$  to energize relay  $K_1$ .

With  $S_1$  in the normally closed position and  $J_1$ ,  $J_2$  open, the collector currents through  $Q_1$  and  $Q_2$  are unbalanced to the point where  $Q_3$  conducts sufficiently to energize  $K_1$ . Shorting  $J_1$  and  $J_2$  balances the collector currents again and  $K_1$  opens.

If a photocell of the cadmium-sulfide type is connected across  $J_1$  and  $J_2$ , changes in illumination will cause the cell resistance to vary, thus producing the same effect as opening and closing the circuit across  $J_1$  and  $J_2$ .

## Reverse Operation

It is sometimes more convenient to actuate the relay by opening a

contact rather than closing it. Using the normally-closed control option permits this to be accomplished and yet if the relay fails, it will fail safe, shutting off the load.

If it is desired to operate the relay from a source of low current, such as a photovoltaic cell, the terminals of the cell are connected to  $J_2$  and  $J_3$  with the positive terminal on  $J_3$ ;  $S_1$  must be on normally open. The action is now push-pull; the  $Q_1$  collector current is increased while  $Q_2$  collector is decreased. The resulting voltage across  $R_9$  and  $R_{10}$  causes the relay to energize.

A slight delay in opening and closing the relay is obtained by closing  $S_2$ . The delay time varies depending on the resistance of the input circuit but it is intended primarily only to prevent relay chatter when a slowly moving, light contact is being made or broken.

Sensitivity control  $R_3$  provides a convenient means of limiting the input current if, for instance, it is desired to reduce the output of a photovoltaic cell because of high ambient light.

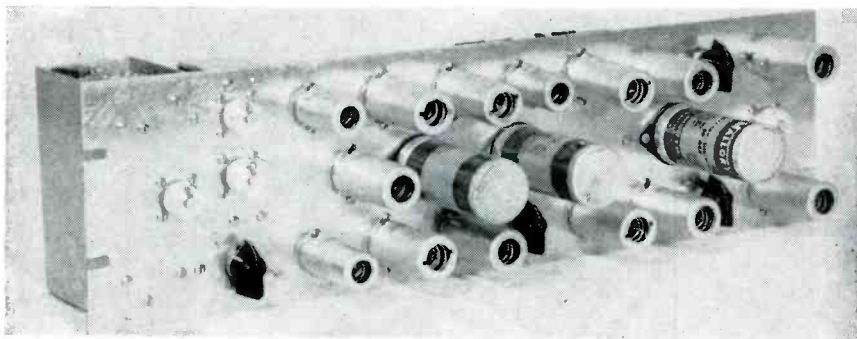

Rack-mounted low-frequency divider chassis achieves phase stability in countdown by using pulse sampling

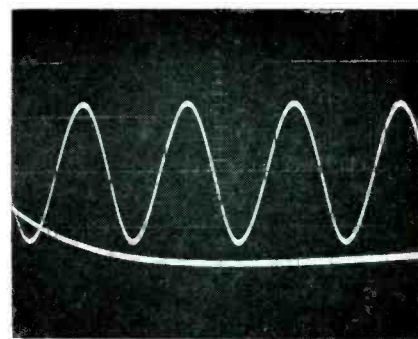

Thirty-minute-exposure waveforms of 2.47-mc (top) and 7.35-kc (bottom) outputs

# SYNC GENERATOR FOR

**P**HASE STABILITY is important in NTSC color television to reduce degradation of the brightness signal caused by the color signal. A phase shift of 0.8 degree at 15 kc in the horizontal synchronizing pulse during the 1/30 second between successive scans would reinforce rather than cancel the dot pattern.

The synchronizing generator to be described was developed for use in a dot-interlace system.

## Sampling Divider

When a stable high-frequency crystal reference is used, the problem of phase stability becomes one of maintaining the output of the divider chain in time coincidence with every  $p$ th cycle of the crystal reference frequency. This may be accomplished by using the output of the divider chain to sample the peak of this cycle of the reference frequency. The sampled output is shaped to form the synchronizing pulse.

The method of sampling used depends upon the frequencies involved. At low frequencies, the square wave outputs from multivibrator dividers may be used to control a gate. At frequencies above 50 kc, sinusoidal dividers are usually used. The outputs of these dividers may be added and clipped to achieve an imperfect type of sampling.<sup>1</sup>

A highly stable pulse can be obtained from a pulse-dividing chain by adding the outputs of the various divider stages and using them to sample the input pulse as illustrated in Fig. 1. A stable multivibrator dividers were used in this particular chain, although the principle is applicable to bistable multivibrators and phantastron dividers.

vibrators and phantastron dividers.

Figure 2 illustrates how the positive pulse duration of each divider is selected so as to select one of the  $p$  pulses that it divides by. The relative phase of these square pulses is chosen to insure that the output pulse is sampled by the flat portion of the square-wave top. The peak square pulse allows one of the input pulses to pass through the gate insuring that the output is in phase with the input.

Jitter in the firing time of the chain multivibrators has no effect on the phase of the output pulse as long as the counting ratio remains constant and the pulse is sampled by the flat portion of the square pulse peaks.

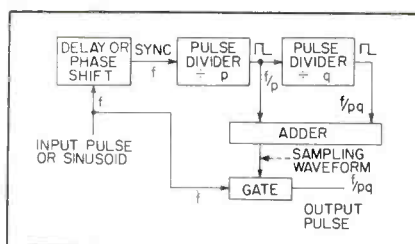

FIG. 1—Basic pulse dividing chain with sampling

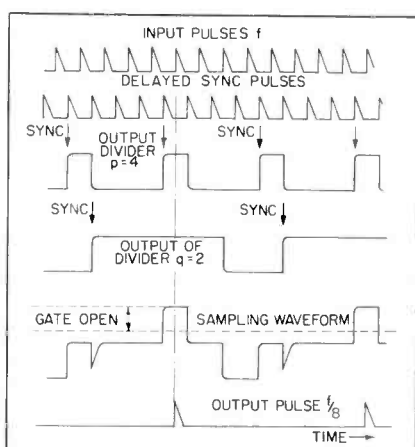

FIG. 2—Pulse relationships in sampling dividing chain

## Experimental Equipment

The high-frequency divider shown in Fig. 3 and 4 was built as a part of a dot-interlace bandwidth-reduction television system.

Crystal oscillator  $V_1$  feeds a 2.47-mc reference signal to buffer  $V_2$ . A link coupled to the buffer stage provides a 2.47-mc sinusoidal output signal.

The first locked-oscillator divider,  $V_3$ , is self-oscillating at 412 kc. The 2.47-mc signal coupled to its grid through the 0.5- $\mu$ f capacitor reacts with the harmonics of the 412-kc signal causing the oscillator to pull in. The oscillator is tuned with the 50- $\mu$ f variable-plate capacitor



**SUMMARY** — Accurately phased horizontal and vertical synchronization pulses are obtained by sampling pulses from frequency divided chains to obtain output corresponding in phase to half-cycle of high-frequency signal. Though design is for 14.7-kc line and 60-cps field frequencies, with 2.47-mc reference frequency, technique is directly applicable to NTSC color systems

By **FRANCIS T. THOMPSON**

*Westinghouse Research Laboratories  
Pittsburgh, Pennsylvania*

# DOT-INTERLACE TV

until pull-in is achieved.

An oscilloscope connected to point A detects lock-in. The 412-kc output of  $V_8$  is used to lock in  $V_4$  at 58.8 kc in a similar manner. The output of  $V_4$  is rectified by the IN34A diode to provide negative pulses which correspond to each negative half cycle of the 58.8-kc output sinusoid of  $V_4$ . This pulse which corresponds to the delayed sync pulse of Fig. 2 is amplified and shaped in  $V_6$  and synchronizes multivibrator  $V_6$ .

The 14.7-kc output of  $V_6$ , which corresponds to divider  $p = 4$  of Fig. 2 is applied to cathode follower  $V_{7A}$ . The output from the plate of  $V_{7A}$  is differentiated by the 100- $\mu\mu\text{f}$  82,000-ohm network and applied to the grid of  $V_{7B}$  where it is clipped to provide a negative 14.7-kc pulse to the low-frequency divider.

This negative pulse also synchronizes multivibrator  $V_8$  whose 7,350-

cycle output corresponds to divider  $q = 2$  of Fig. 2. This output is applied to cathode follower  $V_9$ . The outputs of  $V_{7A}$  and  $V_9$  add in their common cathode resistor to provide the sampling waveform of Fig. 2. The IN34A diode associated with  $V_{11}$  clamps the top of this waveform at ground potential.

### Sampling Portions

The outputs of  $V_9$ ,  $V_8$  and  $V_4$  are added and applied to the grid of  $V_{10}$ . The 75,000-ohm resistor shifts the phase of the sinusoids with respect to each other so the peaks add in phase.

The output of cathode follower  $V_{10}$  is shown in Fig. 5. This waveform which has a peak-to-peak amplitude of approximately 20 v is applied to the grid of  $V_{11}$  where the positive peak of the waveform is clamped at ground potential by the grid diode action.

Grid cutoff is held at a fraction of a volt by dropping plate and screen potentials to approximately 45 v. Only the uppermost peak of the waveform draws cathode current.

The repetition rate of this sharp current pulse is 58.8 kc. This clipping action completes the high-frequency sampling.

Low-frequency pulse sampling is achieved by the sampling waveform of Fig. 2 which is applied to the suppressor grid of  $V_{11}$ . The suppressor allows electrons to reach the plate on every eighth cathode current pulse. The other pulses draw screen current.

The pulse of cathode current occurs at a time corresponding to the center of the sampling waveform peak as illustrated in Fig. 2 because the negative half cycle of  $V_4$  synchronizes the countdown multivibrators.

The 7,350-cps narrow plate pulse of  $V_{11}$  is inverted and amplified by  $V_{12}$  and applied to cathode follower  $V_{13A}$ . The output charges the 100- $\mu\mu\text{f}$  capacitor through the IN48 diode. The charge leaks off through the 270,000-ohm resistor in parallel with the condenser providing a much wider pulse that is applied to output cathode follower  $V_{13B}$ . The output of  $V_{13B}$ , shown in Fig. 6, acts as the horizontal synchronizing pulse. The leading edge of this pulse is in phase with the peak of

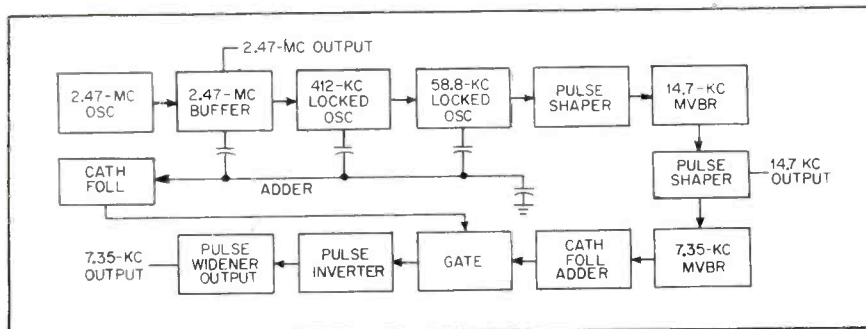

FIG. 3—Block diagram of high-frequency divider used in dot-interlace television system

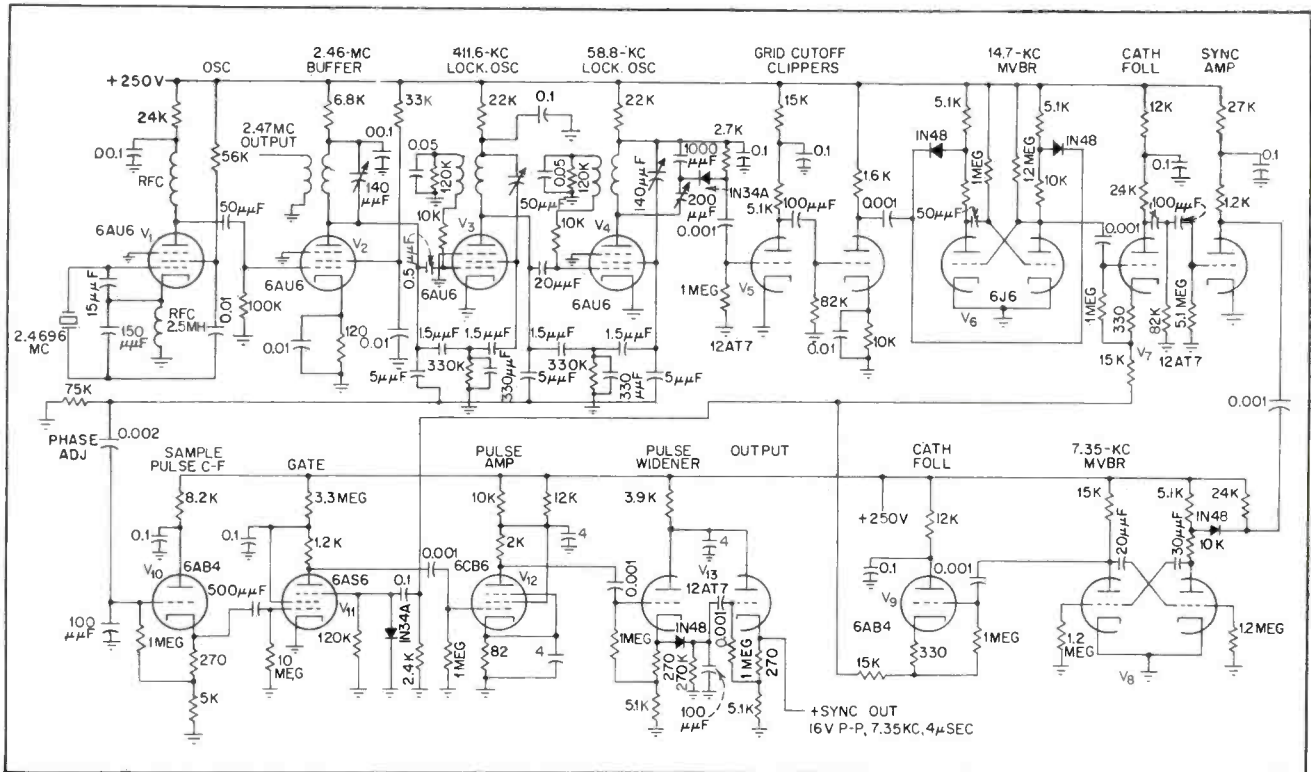

FIG. 4—High-frequency divider counts down 2.47-mc reference frequency to 14.7-kc horizontal line frequency

corresponding cycles of the 2.47-mc output.

### Low-Frequency Divider

The low-frequency divider is shown in Fig. 7 and 8. The 14,700-cps output of the high-frequency divider is applied to the input of

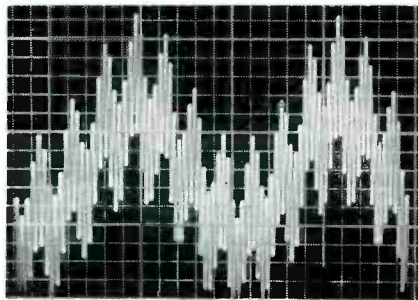

FIG. 5—Composite sampling waveform before clamping and clipping

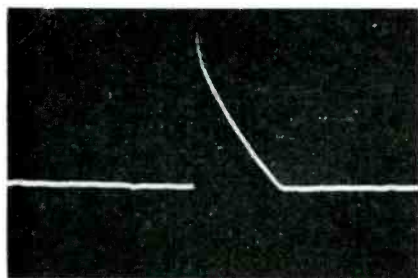

FIG. 6—Horizontal sync pulse has leading edge in phase with peak of corresponding cycles of 2.47-mc reference signal

this divider through the 14- $\mu$ sec delay line in the cathode of  $V_{1A}$ . This pulse is amplified by  $V_2$  and used to synchronize multivibrator  $V_3$ , which has an output frequency of 2,100 cps.

The output of  $V_3$ , which is applied to cathode follower  $V_{4A}$ , consists of a positive pulse similar to divider output  $p$  of Fig. 2. The width of this pulse is approximately  $1/14,700$  second corresponding to  $p = 7$ .

The opposite polarity output of  $V_3$  is differentiated and clipped by  $V_{1B}$  to provide a synchronizing pulse for multivibrator  $V_5$ , which provides a pulse to cathode follower  $V_{6A}$  at a frequency of 300 cps and a synchronizing pulse to clipper  $V_{6B}$  that synchronizes  $V_7$ . Multivi-

brator  $V_7$  provides an output pulse to cathode follower  $V_{8A}$  at 60 cps and a 60-cps test output signal.

The cathode follower outputs are added in the 8,200-ohm common cathode resistor to provide the waveform shown in Fig. 9. The peak of this waveform is clamped at ground potential by  $V_{1B}$  which acts as a diode. This waveform is applied to the suppressor of  $V_{12}$  where it acts as the gating waveform.

### Signal Path

Following the path of the input signal through the sampling portion of the divider, the input signal is inverted by  $V_{11A}$  and applied to the grid of gate  $V_{12}$ , which is controlled by the gating waveform.

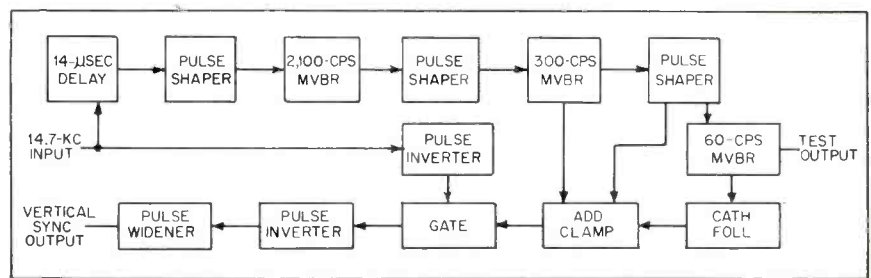

FIG. 7—Low-frequency divider uses pulse-sampling technique to achieve phase stability in counting down 14.7 kc to 60-cps vertical field rate. Vertical sync pulses are in exact phase with every 245th input pulse









# of Junction Transistors

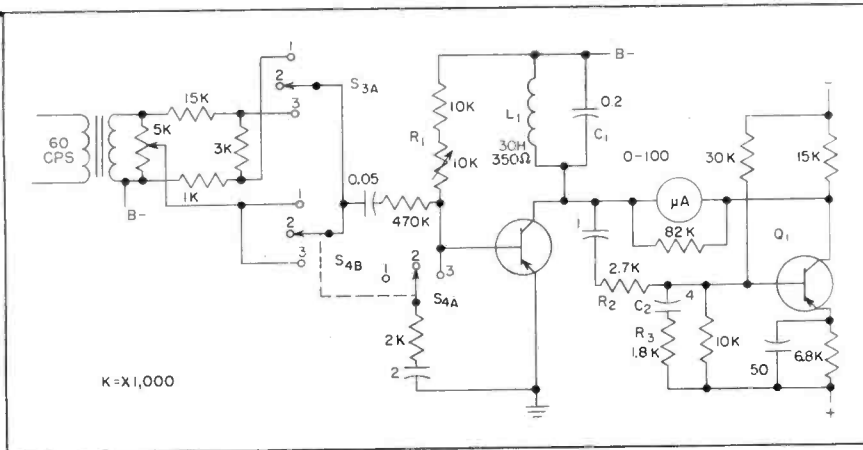

FIG. 3—Circuit used for measuring transistor beta and input impedance

Transistor is attached to tester with spring clips (at right)



characteristic being measured. One switch turns the meter on and chooses power supply polarity for *npn* or *npn* types.

With the other switches in their neutral positions the tester monitors static collector current as shown in Figure 2A. Current may be adjusted with  $R_1$  to test transistors at currents from 0.15 to 15 ma with full-scale deflections of 2 and 20 ma.

The full-wave rectifier a-c meter responds equally well to d-c currents of either polarity, hence requires no lead reversal with change in transistor type. Collector-current range switch  $S_1$  alters the meter shunt and adds a voltage divider. This arrangement provides a constant driving impedance for the meter so the scale non-linearity will be identical on low and high-current ranges. In position 3, it also places a purely resistive load on the transistor so auxiliary tests of cut-off frequency may be carried out using the tester as a device for furnishing power and controlling the operating point of the transistor.

### Collector Leakage

The emitter-open transistor leakage,  $I_{co}$ , is measured with  $S_2$  in Fig. 1 in position 1. The meter is placed in series with the transistor with only a high-impedance shunt, as

shown in Fig. 2B. The shunt in Fig. 2C was chosen to adjust the a-c meter to read 100  $\mu$ a d-c full scale.

Base-open leakage  $I_o$  ( $I_b = 0$ ) is measured similarly, but  $S_2$  in position 3 adds a shunt across the meter to reduce full scale sensitivity to 2 ma.

### Current Gain

To measure current gain a known a-c is fed in the transistor base and the output current measured. Output current is then proportional to  $\beta$  and the meter can be calibrated directly in terms of gain.

Two precautions are necessary to insure reliable readings.

To operate the transistors properly at large collector currents a low-impedance d-c load must be used; this load must not shunt the a-c signal away from the meter circuit. To meet these conditions, shunt choke  $L_1$  in Fig. 3 was chosen. The choke drops only 5 v d-c due to a static current of 15 ma and yet conducts only a small portion of the a-c signal. Nevertheless, this alternating current conduction is important (particularly at small output indications where the meter impedance rises to more than 10,000 ohms) in accurate measurements because the inductance varies with static current and thus the fraction of the signal shunted may

be a function of the current in the choke.

Capacitor  $C_1$  minimizes the variation in signal shunting by tuning the inductor below the 60-cps signal frequency. Thus, as the inductor current increases, the inductance drops but the resonant frequency increases closer to the signal frequency. In this way, signal impedance can be maintained nearly constant.

Beta is defined as the base-to-collector current gain with the collector shorted to ground. Shorted means that the impedance must be smaller than the transistor output impedance  $r_o$ . This criterion is not automatically met for an a-c rectifier meter and a moderate power transistor; it is not uncommon to find output impedances of the order of a few thousand ohms which is less than the impedance of a 100-microampere a-c meter to a 25-microampere signal.

To remedy this situation a one-stage transistor amplifier comprising  $Q_1$  was added to reduce the effective impedance of the meter. If the potential at the collector of the transistor under test rises, for instance, the change is amplified and inverted in phase by  $Q_1$ . The current which flows back through the meter to the collector of the test transistor due to this inverted signal is nearly the opposite of the

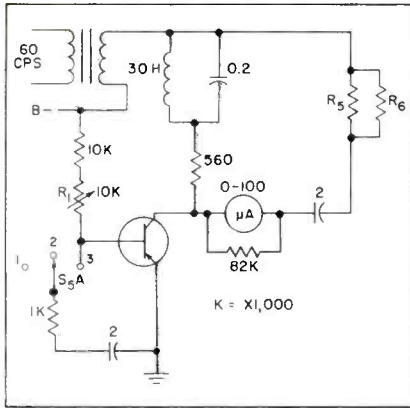

FIG. 4—Output resistance measurement ohmmeter circuit

collector current of the tested unit. Hence, little net unbalanced current results at the collector terminal.

The detector-unit impedance is approximately the total resistance in the base circuit  $Q_1$  divided by its current gain. For the circuit in this tester the effective impedance is about 100 ohms, much less than most transistor output impedances. Resistors  $R_2$ ,  $R_3$  and capacitor  $C_2$  in the base circuit of  $Q_1$  form a phase-shift correcting network to prevent self oscillation of this feedback amplifier.

The base-collector current gain is measured by injecting a known 60-cps current from a high-impedance source into the base and reading the output current. Two choices of input current are available by switch  $S_{2A}$ , roughly  $\frac{1}{2}$  or 2  $\mu\text{a}$ . These correspond to full-scale current-gain indications of 200 or 50.

#### Input Resistance

Transistor input resistance  $r_i$  is measured with a circuit arrangement similar to that used in determining  $\beta$ . An unknown base signal current is adjusted to make the output meter read full scale and then a portion of this base current is shunted away from the base through resistor  $R_4$  in Fig. 3 by  $S_{1A}$ . The fraction of current still entering the base is

$$i/i_o = R_4 / (R_4 + r_i) = (1 + r_i / R_4)^{-1}$$

from which the input resistance scale may be calibrated. For example, since  $R_4$  is 2,000 ohms, a half-scale reading after adjustment and shunting means the input resistance is 2,000 ohms, a two-thirds full-scale reading means 1,000 ohms

and a one-third, 4,000 ohms.

An a-c operated ohmmeter is used for measuring the output impedance with the base at a high signal level impedance ( $r_o$ ) or at 1,000 ohms ( $r_o'$ ). Figure 4 illustrates how the meter is placed in series with an alternating potential, a fixed resistance and the transistor being tested. The meter current, neglecting the choke shunt, is

$$i_m = e_s / (R_s + R_m + r_o) \\ = \frac{e_s}{(R_s + R_m)} \left[ 1 + \frac{r_o}{R_s + R_m} \right]^{-1}$$

where  $e_s$  is the applied potential,  $R_s$  is the series resistance,  $R_m$  is the meter resistance and  $r_o$  is the measured transistor resistance. Metered output current  $i_m$  changes with output resistance  $r_o$  in the same manner as shown above for the input resistance. Consequently, the same scale divisions can be used. Proper choice of  $e_s$  and  $R_s$  multiply the resistance scale by 10 to ensure that the scale center corresponds to a typical output resistance value. Because the meter impedance changes with applied current the given expression is not precise, but if the series resistor and the applied potential are experimentally fixed with  $R_s$  so zero resistance is full scale and 20,000 ohms is half scale, adequate accuracy is available for all but the most precise applications.

#### Construction Features

The relative position of the power transformer and load inductor can result in an induced potential in the inductor and a spurious bias in the meter reading. The positions used were chosen empirically by connecting the meter across the inductor and moving the transformer to various places until a point was found which produced negligible pickup.

The power transformer used to operate the transistors and furnish the a-c test signal is a modified Stancor 6134 filament transformer. The high-current secondary was removed and in its place a 6.8-v power winding and 5.3 and 3.0-v signal windings were wound. It is not necessary that the two signal windings be separate, a 3-v tap on the 5.3-v secondary would be satisfactory.

Regulation of the transistor power supply will be a little better if a full-wave rectifier is used with a center-tapped 13.6-v winding. This would also aid the filtering possibly circumventing the use of a choke filter element—and increasing the ripple frequency well above the signal frequency.

The inductive kick of the transistor-load choke when the current is abruptly changed with 15-ma flowing in the choke produces over a 100-v pulse, enough to ruin the majority of transistor types. Because of this pulse, a transistor should never be pulled from the socket with the power on. Switch  $S_{2A}$ , a section of the power switch, shorts the inductor as the power is turned off, safeguarding the transistor.

When the meter is switched to read leakage current, the d-c collector current is rapidly interrupted, making control of the switch opening sequence important if the resultant inductive pulse is not to ruin all transistors tested. Switch  $S_{2B}$  shorts the inductor and going from position 2 to 1 it closes before  $S_{2A}$  grounds the transistor base interrupting collector current.

It is also important that  $S_{2B}$  break contact going from position 2 to 3 and cut off the base current to the transistor before  $S_{2C}$  removes the low-impedance meter shunt or else the meter will be an a sensitive current scale while still carrying the full static collector current. To insure these contact sequences,  $S_2$  must be modified.

#### Battery Operation

In instances where self-contained operation would be an advantage, battery life would be excellent since instrument warm-up is not required and current is not drawn except when actually testing. A Burgess B5 battery should furnish 500 to 1,000 hours of testing under normal circumstances.

This modification necessitates an internal oscillator that could be a neon-bulb type operating from 67½-v battery or a transistor audio oscillator. A reduction in size of the transistor load choke and coupling capacitors can be achieved by running the oscillator at a higher operating frequency.





Plug-in unit fits into the standard nine-pin noval socket. Base is hermetic-seal structure  $\frac{7}{8} \times 1 \frac{1}{16}$  in., with overall height  $2\frac{5}{8}$  in.

# Three Oscillator Designs Standardize Circuitry

By H. E. GRUEN

Associate Engineer  
Armour Research Foundation  
Chicago, Ill.

**SUMMARY** — Thirty-nine existing crystal oscillator circuits shrink into three basic designs using MIL-approved crystals and subminiature tubes. Up to 2.5 octaves within range of 0.8 to 75 mc are covered by unit occupying less than 2.5 cu in. Below 16 mc, untuned circuits afford frequency stability of 5 to 10 ppm. Plug-in package design may be varied physically for special applications without sacrificing any of the specified performance features

**A**NALYSIS of present crystal oscillator circuitry including four generic types and a few special-application designs, has been made to determine requirements for a series of standardized, packaged units. Data obtained for each of 39 circuits includes type of crystal, operating frequency, stability, output voltage, crystal drive level and operating conditions peculiar to each circuit. As a result of this survey, three basic oscillators, a Colpitts, electron-coupled Colpitts and cathode-coupled were designed.

The Colpitts and electron-coupled Colpitts have untuned circuits with plug-in crystals or any number of external crystals in a switching network. The high-frequency

cathode-coupled types require adjusting tuned circuits when changing frequency. If many crystals are used, tuning is done externally. These circuits provide highest output voltage consistent with stability and drive level requirements. Design criteria developed previously<sup>1</sup> and additional experimental work produced circuits covering the 0.8 to 16-mc range.

## Colpitts Oscillator

The Colpitts circuit is shown in Fig. 1A with component values for each of the three ranges. The 5636 ruggedized subminiature pentode is triode-connected. The correct crystal load capacitance of  $32 \mu\mu\text{f}$  and the proper ratio of  $C_s/C_c$  occurs when the oscillator couples to a

circuit having an input capacitance of  $15 \mu\mu\text{f}$ .

Current requirement is about 4 ma at operating voltage. Frequency change is from 0.5 to 1 ppm for a 10-percent change in supply voltage, with the operating frequency dependent on the load capacitance. Using commercially-available 5-percent capacitors all circuits operate within 5 to 10 ppm of the crystal antiresonant frequency.

## Operating Characteristics

Output voltage and crystal drive level are shown in Fig. 2A. The range of values was obtained using production CR-18/U crystals. Any military type designed to operate at antiresonance into a  $32\text{-}\mu\mu\text{f}$  load

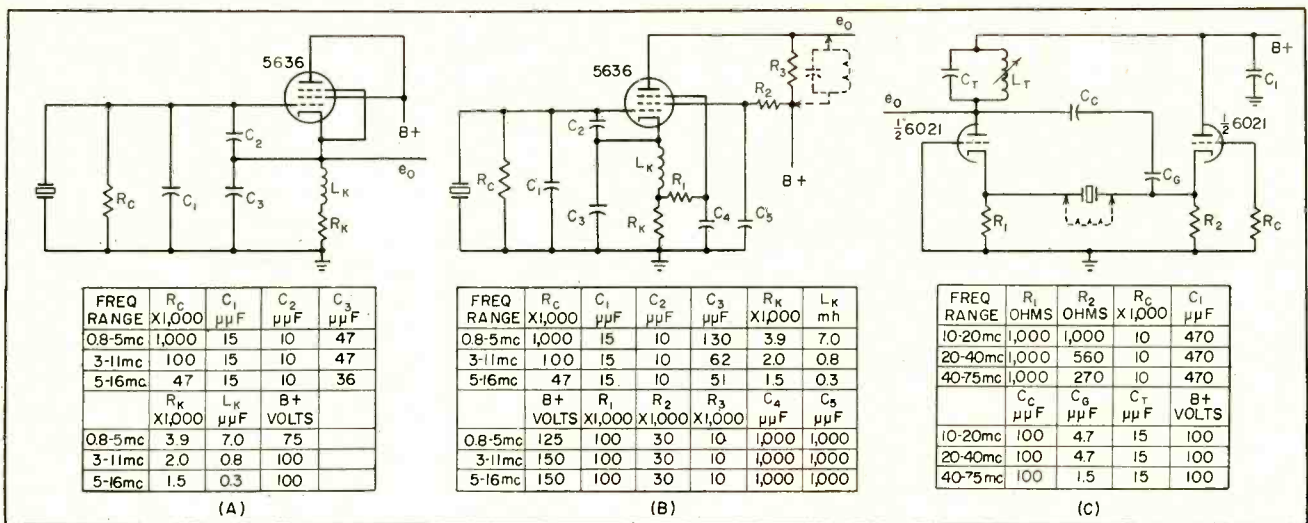

FIG. 1—Circuits and component values of Colpitts (A) electron-coupled Colpitts (B) and cathode-coupled (C) crystal oscillators

in the range 0.8 to 16 mc may be used. This includes the CR-18/U, CR-27/U and CR-36/U.

As shown in Fig. 2A the factor limiting output voltage is the crystal drive level. Since the ratio of crystal drive voltage to output voltage is constant for given operating conditions, the crystal drive power level increases as the square of the voltage. Thus there is little increased output for much greater crystal dissipation.

Low-frequency, high-resistance crystals are difficult to start in a circuit which drives at high power levels. This is caused by high initial circuit gain. With fixed crystal parameters, reducing the tube transconductance when not oscillating can lower the initial gain. Oscillations then stabilize at lower amplitude with reduced output and crystal drive level.

### Electron-Coupled Colpitts Oscillator

Electron-coupled crystal oscillators offer advantages of ease of frequency multiplication, high ratio of output voltage to crystal drive and control frequencies independent of load-impedance variations. The Colpitts circuit adapts to electron coupling since the plate operates at a-c ground. This allows use of a tetrode or pentode, with the screen grid acting as the oscillator plate. The circuit of the electron-coupled oscillator is similar to the Colpitts, with the addition of a plate load circuit. Resistor  $R_2$  reduces the screen voltage to less than the plate voltage.

The electron-coupled circuit is shown in Fig. 1B. Components in the oscillator portion are nearly identical to those of the Colpitts, but in the middle and high bands  $C_3$  is 15  $\mu\mu\text{F}$  larger. This yields the same feedback ratio as the Colpitts operating into a 15- $\mu\mu\text{F}$  load. In the low-band circuit  $C_3$  is much larger. This reduces the amplitude and allows plate current flow for more of the cycle. Otherwise the output at the plate load would be small due to cutoff.

The Colpitts circuit tube type is also used in the electron-coupled arrangement, with decoupled biasing in the suppressor-grid circuit. A 10,000-ohm resistance provides a fixed load and d-c path for plate current. Two sets of output voltage curves under two plate load conditions, are shown in the upper graph of Fig. 2B. The lower curves represent output when the 10,000-ohm load is used alone. The upper curves represent rms output when a circuit tuned to the crystal fundamental is added as shown in Fig. 1B.

The harmonic output obtainable is a function of the load impedance at the desired frequency and the harmonic content of the plate current. The lower graph of Fig. 2B shows peak-to-peak plate current in the three circuits. This was determined by measuring voltage across a 100-ohm load, thus minimizing the effect of stray capacitance on the wave shape. The curves can be used to compute the output at any load impedance.

Plate current waveforms at three frequencies are shown in Fig. 3. Measurements were made using plate supplies of 100 and 150 volts, with the values of  $R_2$  chosen to maintain 75 volts at the screen. The peak-to-peak current at 100 volts is slightly less than the 150-volt values with the waveform nearly unchanged, indicating that operation is independent of plate voltage. Measurements at higher frequency show waveforms similar to those at 5 mc with plate current values of Fig. 2B.

### Waveform Analysis

A Fourier analysis of the waveform produced by a 1-mc, 240-ohm crystal in this circuit is approximated by the broken line of Fig. 3. The result can be expressed in terms of the peak amplitudes by  $C_n = I_{p,n}/(n\pi + 1)$  where  $C$  is the Fourier coefficient at the  $n$ th harmonic.

Using this equation the designer may predict the output voltage of the electron-coupled oscillator when the impedance at the desired harmonic frequency is known. As an example, the fundamental and second harmonic output of a typical 1-mc crystal unit with a plate impedance of 5,000 ohms at both frequencies is calculated as shown. From Fig. 2B the peak-to-peak current at 1 mc is 10 ma. Then  $C_1 = 10/4.14 = 2.42$  ma p-p = 0.865 ma rms; and  $C_2 = 10/7.28 = 1.37$  ma p-p = 0.49 ma rms.

The output voltages at each harmonic are then:  $e_{o1} = i_{rms1} Z_L =$



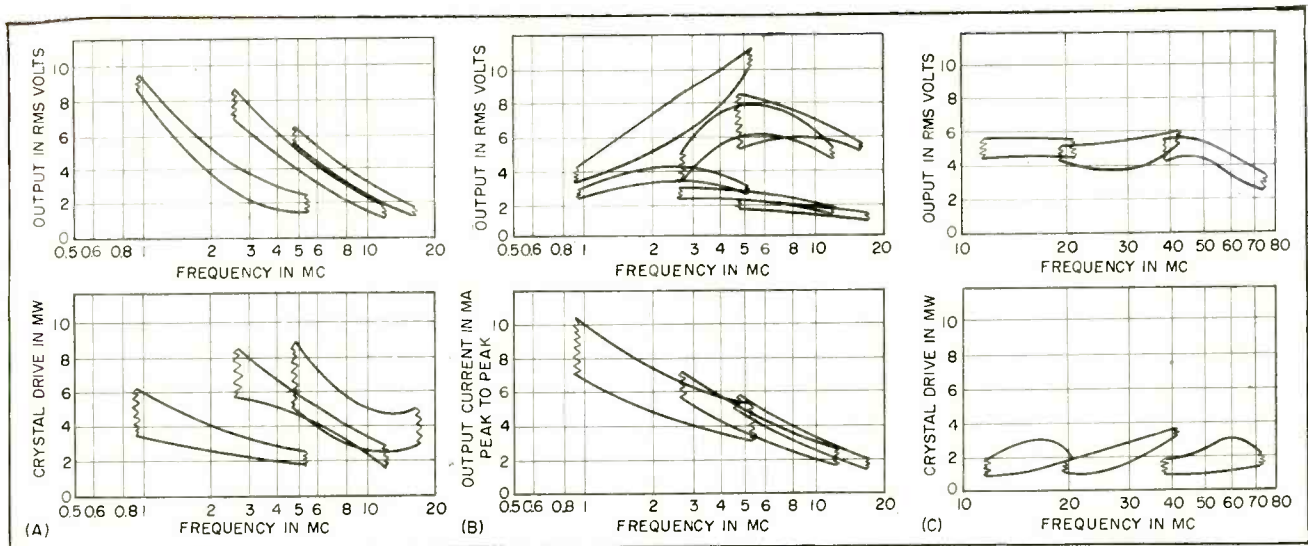

FIG. 2—Measured performance characteristics in three ranges of Colpitts (A), electron-coupled (B) and cathode-coupled (C) units

$0.865 \times 10^{-3} \times 5,000 = 4.3$  volts (fundamental); and  $e_{o2} = i_{r_{m2}} Z_L = 0.49 \times 10^{-3} \times 5,000 = 2.44$  volts (2nd harmonic).

These circuits also require about 4 ma of current at the specified plate voltage. Frequency change for a 10-percent variation in supply voltage is from 0.5 to 1 ppm, and as the plate load circuit is tuned through resonance at the fundamental the change is 3 to 4 ppm. The operating frequency, as for the Colpitts circuit, is within 5 to 10 ppm of the crystal antiresonant point. Military crystals CR-18/U, CR-27/U, and CR-36/U may be used.

### Cathode Coupled Oscillator

The cathode-coupled oscillator covers from 10 to 75 mc. A dual triode is used, one section as a grounded-grid amplifier, the other as a cathode follower. Feedback is between the two cathodes through the low-impedance path of the crystal at series resonance. Crystal operation at exactly series resonance requires zero phase shift around the circuit loop. The various stray capacitances must therefore be compensated by the circuitry. This cathode follower is free of phase shift over a wide frequency range due to the small grid-to-cathode capacitor shown in Fig. 1C.

The input capacitance of the grounded-grid stage is resonated at a given frequency. Then the cathode follower load is the crystal resistance in series with the am-

plifier input impedance, plus the effect of the cathode resistors. With the plate tank tuned to resonance, oscillation will occur at the series-resonant frequency of the crystal.

When the tank circuit is tuned for maximum output voltage or grid current, the operating frequency varies directly with Q and plate tank impedance and inversely with capacitive phase shift in the cathode circuits. Tuning the cath-

circuit components resonate at each frequency. A variable inductance resonates with the total circuit capacitance of about  $15 \mu\text{f}$ . Preferred military crystal types include CR-32/U, CR-52/U, CR-54/U, CR-55/U, and CR-56/U.

At 40 mc and higher, uncontrolled oscillations may occur due to feedback through the crystal capacitance when the plate tank is detuned from the crystal frequency. These can be eliminated by resonating the capacitance with a low-Q inductor which operates over a wide frequency band. The network impedance prevents oscillation throughout the tuning range of the plate tank. The required turns of wire wound on a 1/2-watt, 1,500 to 2,200-ohm resistor work well. The inductance value is chosen to tune the crystal shunt capacitance to the center of the operating band.

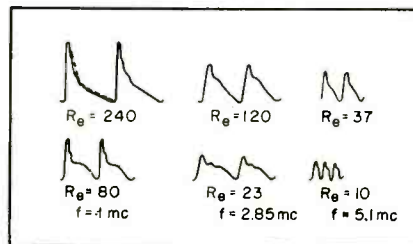

FIG. 3—Electron-coupled plate current waveforms. Broken line approximates Fourier analysis of the 1-mc crystal unit

ode circuit over a band of frequencies is not recommended. The operating frequency of the oscillator will be above series-resonance of the crystal at the low end of the band and below it at the high end. The range is 10 to 20 ppm due to variation in crystal Q and the repeatability of tuning.

### Circuit Variations

Three variations of the basic circuit of Fig. 1C cover the 10 to 75-mc frequency range. The tank

### Typical Performance

Performance data for the three cathode-coupled circuits are shown in Fig. 2C. The lower graph shows that drive levels with typical crystals are centered about 1 mw.

The author acknowledges the help of E. H. Borgelt of Wright Air Development Center in his design recommendations and of J. S. Kurinsky of Armour Research Foundation who constructed and tested the units.

### REFERENCE

- (1) H. E. Gruen, How to Design Colpitts Crystal Oscillators, *ELECTRONICS*, 30, p 146, Jan. 1957.

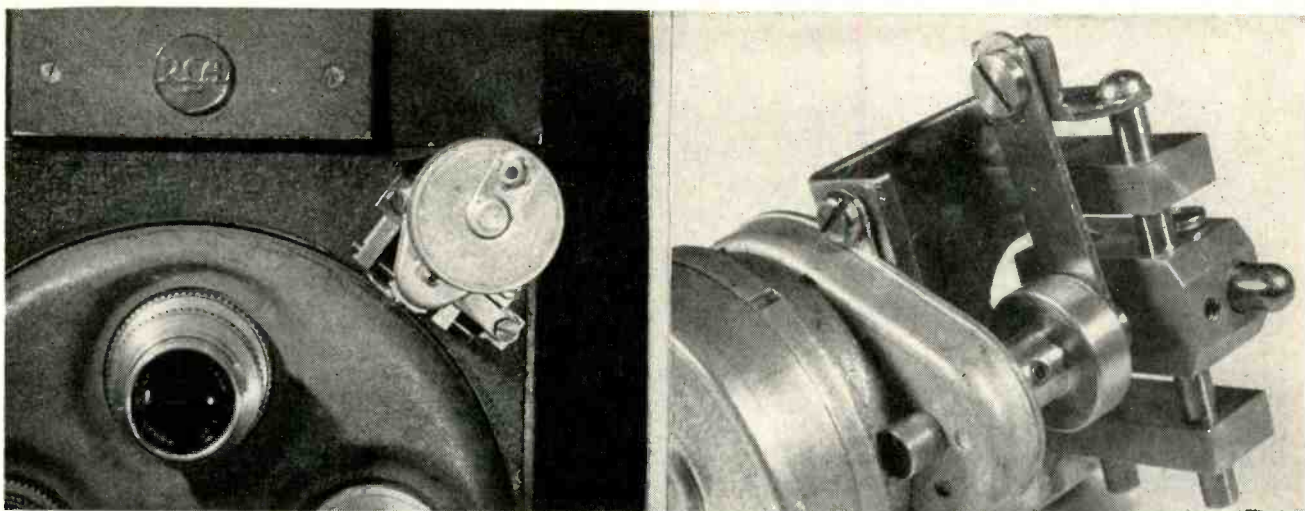

Mounting position of antiburn device that oscillates tv camera lens board (left) and mechanical details of device showing cam-operated detent (right). Work is now progressing on device to move lens board in circular orbit for even better burn-in immunity

# Motion Minimizes Image

**SUMMARY** — By oscillating lens board of tv camera at slow rate, image orthicon burn-in is reduced as much as 90 percent. Horizontal centering circuit in camera is modified to cancel resultant horizontal motion. Details of circuit modification and results of tests on discarded tube are given

**EXPENSIVE IMAGE - ORTHICON** tubes used in television cameras often have to be discarded simply because of an inherent weakness in which the image orthicon retains a previous camera shot. Experience at WBAL-TV and WISN-TV has shown that about 25 percent of the tubes so discarded resulted from this weakness, sometimes known as burn-in or stickiness. Especially exasperating are the times when some of the best image orthicons have to be discarded when other characteristics such as tonal composition, flatness of field, noise level and freedom from blemishes are especially good.

## Causes

Burn-in is caused by two separate and distinct forms of operation. The first is the burn-in on the photo-sensitive surface behind the front plate of the tube itself which results when the camera is focused

on a bright object. This occurs whether or not the camera is on,

hence the importance of capping the lense when the camera is not in use.

Second, and more important, is burn-in on the target itself. This occurs only when operating potentials are present on the tube.

## Correction

The method by which the latter may be corrected consists of slightly moving the focused scene on the image-orthicon tube. Two problems had to be overcome to do this. The first problem was that of interference of the detent mechanism on the camera. This problem is resolved by immobilizing the normal detent of the camera and fabricating a new detent arrangement on the lens turret. This detent consists of a rounded steel pin engaging four recesses, each corresponding to one of the lenses. The detent pin, mounted on a carriage, is slowly moved back and forth by

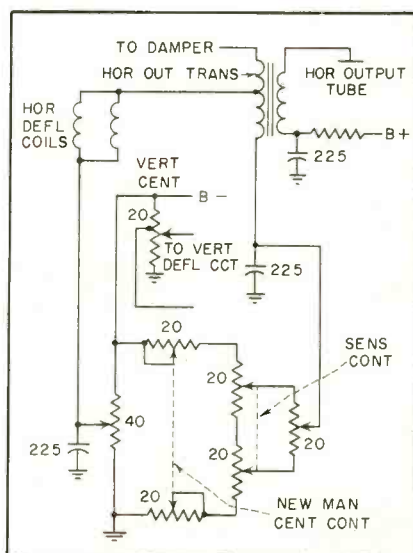

FIG. 1—Horizontal circuit modification required in RCA TK-30 field camera to produce stationary image while lens board is oscillating horizontally



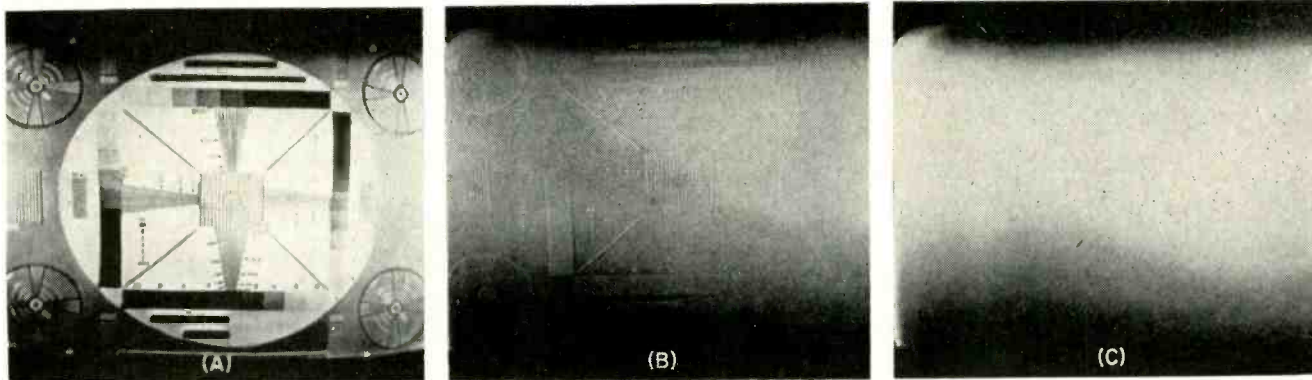

FIG. 2—Effects of burn-in are graphically demonstrated by comparing normal test pattern on master monitor (A) with monitor appearance after tv camera is panned to white card (B). Monitor appearance under same conditions but with antiburn device on (c)

By JOHN T. WILNER

Director of Engineering  
WBAL-TV  
Baltimore, Maryland

# Orthicon Burn-in

a heavy-duty clock motor.

The second problem was the physical motion of the television picture on the television receiving sets and monitors. This turned out to be minor since most television shots are usually of short duration and during actual on-the-air experiences it was found that this motion was not objectionable.

However, there are times when no motion can be tolerated. Because of this, electrical horizontal cancellation of the motion is used. For nontelevision use, the horizontal physical motion of the picture is of no consequence and no means of cancellation is required. The rate at which the motion takes place is

about one revolution in about two minutes.

Figure 1 shows one method of electrical cancellation of horizontal motion. This potentiometer arrangement is connected into the horizontal centering circuit of the television camera and electrically centers the picture opposite to that of the mechanical movement. The manual horizontal centering adjustment is still available for normal requirements. A carbon potentiometer allows smooth centering movement.

## Results

Figure 2A shows a typical RETMA test pattern that was

photographed directly from a master monitor. The illumination on the test pattern was 150 foot-candles. The tv camera lens opening was f11. The photographing camera lens opening was f2.8 and the exposure was one-tenth of a second. All subsequent tests were photographed using the same camera settings.

The test pattern was focused by the tv camera and exposed for one minute. The image orthicon used for all of these pictures was one which had been discarded because of excessive burn-in. This tube had been in operation for 460 hours, against an average of 850 hours.

The television camera, with the antiburn mechanism turned off, was then horizontally panned to a white card having the same illumination after one-minute exposure on the test pattern. Figure 2B shows the effect of the test pattern burn-in. Figure 2C was taken under conditions identical to Fig. 2B except that the antiburn mechanism was turned on. Figure 3A shows the camera focused on identification card with the antiburn mechanism turned off. The burn-in is clearly visible. Figure 3B shows the same result with the antiburn device working.

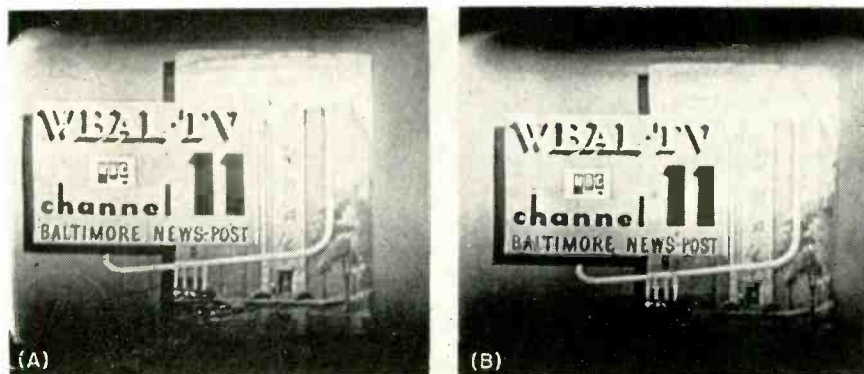
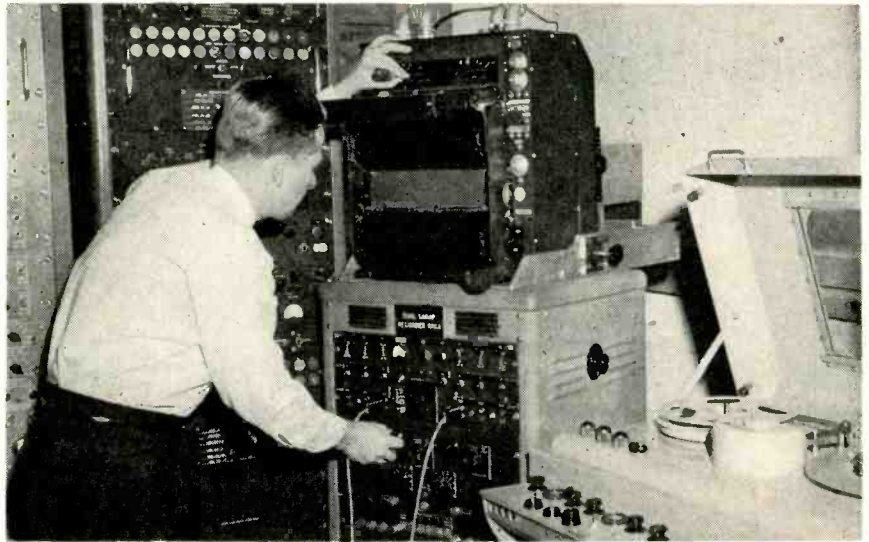

FIG. 3—Burn-in effects without the antiburn device (A) and with the device (B)

By H. B. RIBLET

*Applied Physics Laboratory  
The Johns Hopkins University  
Silver Spring, Maryland*



Operator lines up one channel of dual channel data plotter. Tape playback unit at right feeds telemetered data to discriminators mounted in rack behind operator

# Automatic Data Plotter

**SUMMARY** — Need for manually reading and replotting telemetered data is eliminated by device that automatically plots data as function versus real time and effects 60-to-one saving in man-hours. Recording characteristics can be made to conform with transfer function of telemetering system, relating data values and corresponding displacements, whether linear or nonlinear, with prescribed scale factor

**M**OST TELEMETERING SYSTEMS and in particular f-m/f-m telemetering systems that are used in many guided-missile programs, employ standard photographic recording oscillographs and complex manual operations to obtain the final plots of function versus real time.

During the past few years, a number of systems have been proposed and built to speed the process of data reduction and to eliminate a number of these complex steps. The simplified automatic data plotter to be described performs many of these steps automatically and provides a direct plot of function versus real time with a great saving of time. This system provides a method of photographically printing a calibrated scale

grid and a time grid simultaneously with the data trace.

Figure 1 shows a block diagram of the SADAP. The usual frequency discriminator and calibrator, together with the optical galvanometer, are supplemented with a scale grid projector and time-grid strobe-flash tube.

The scale grid template is constructed directly from the frequency-function calibration curve in a separate pantograph device and has the same characteristics as the function scale card which is used to read the data manually. However, in this case, the scale grid is photographed continuously along with the data trace, making it unnecessary to tabulate and replot the data. The time grid is also photographed simultaneously and can be

synchronized with the real field time values.

The calibration procedure of the recorder thus becomes a simple operation of inserting particular frequencies corresponding to specific function values as read from the function - frequency calibration curve. These specific frequencies are inserted into the recorder from the frequency calibrator and the sensitivity and zero of the galvanometer are adjusted so the recording sensitivity agrees with the function scale.

The function grid may be made to correspond to any transfer characteristic desired, as indicated in Fig. 1, where the scale grid is shown as a nonlinear function. This system therefore has a distinct advantage over a preprinted



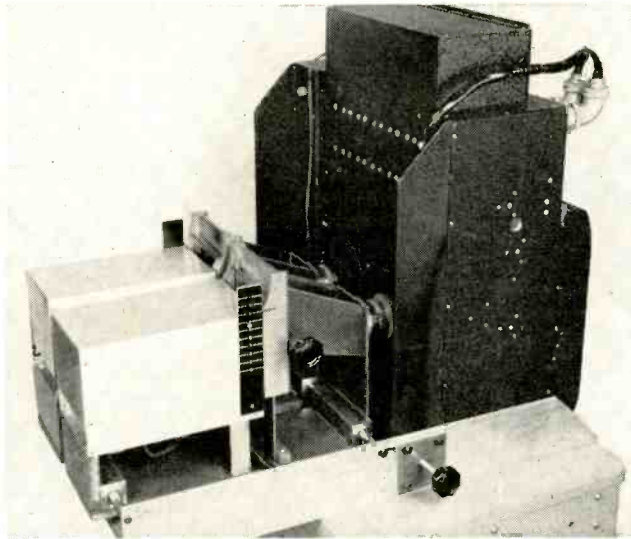

Rear view of dual-channel automatic data plotter shows scale-grid projectors mounted on rear of galvanometer recorders

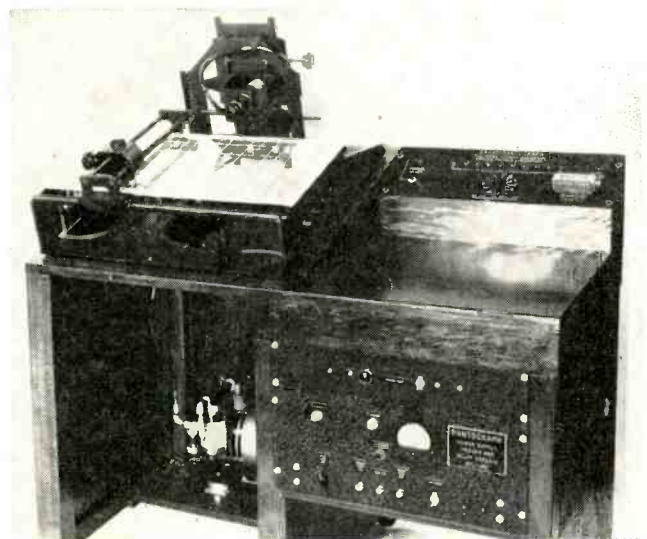

Calibration curve pantograph assembly on top of cabinet has strobe-tube circuits installed in cabinet

# for F-M/F-M Telemetering

grid system or a photographic system which has no function-grid lines at all. At the same time it maintains a high-frequency response of better than 1,000 cps by use of an optical writing system.

## System Description

The plotting system consists of three main parts, a galvanometer recorder, a time-pulse generator and a scale-grid pantograph.

The galvanometer recorder is a standard unit which has been modified to provide the optical elements necessary for the superimposition of the function-scale grid, the time grid and the data trace. The standard 30-cm optical lever arm is preserved, but the standard timing system is replaced by a gas-dis-

charge strobe tube which can be triggered from a pulse-generating circuit.

## Galvanometer Recorder

Figure 2 illustrates the recorder proper. The blocks at the top of the diagram indicate a source of data, that originates from telemetering data stored on magnetic tape. A system of subcarrier discriminators and low-pass filters is necessary for conversion of the f-m data into an electrical current to stimulate the magnetic galvanometer.

The galvanometer light source consists of an incandescent-lamp line filament which is projected onto the galvanometer mirror, thence to the half-silvered mirror

directly under the collimator lens and film plane.

The function-scale-grid film or template is an opaque film with transparent slits that represent the scale-grid lines to be photographed on the film. The image of this template is projected by a standard optical projection lens through the half-silvered mirror and the collimator lens directly onto the film plane. The strobe-flash tube which generates the time grid is contained in a light seal with a slit window whose image is projected onto the film plane in a path parallel to and coincident with the optical path from the galvanometer mirror.

Thus, this optical system superimposes three images: one from the galvanometer mirror; one from the scale-grid template and one from the strobe-flash tube which generates the time grid. As the film is driven past the exposure window, the function-grid lines are photographed as horizontal lines for the full length of the record; the time grid is photographed as vertical lines sequentially along the record and the galvanometer produces a continuous data trace on this

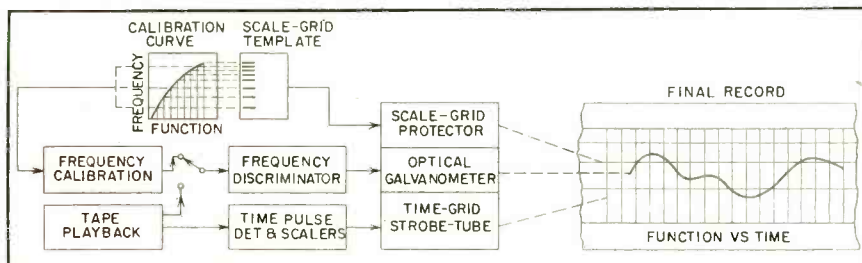

FIG. 1—Block representation of simplified automatic data plotter or SADAP

time and function grid system.

Though Fig. 2 shows a one-channel system, more than one channel can be recorded, depending on the design of the photographic unit.

### Time-Grid Generator

Figure 3 shows a simplified diagram of the time-grid generator. This system controls the light intensity of the flash tube that illuminates the timing grid.

A train of pulses, representing actual field time as recorded on the magnetic tape and detected during playback, are fed into the A scaler. Here the pulses are increased in magnitude and given a sharp leading edge suitable for triggering a standard bistable - multivibrator scaler stage.

The preset scaler, shown in Fig. 4, incorporates four GE 4SN1A3 binary stages to count the pulse train and provide an output pulse at any predetermined number of input pulses. The binary units (Fig. 5) have a 6J6 reset-pulse amplifier connected to each triode through selector switch S<sub>1</sub>. This switch allows a selected reset configuration, which can give a predetermined ratio of input pulses to output pulses. Thus, each group of four binary stages is reset to a particular configuration each time an output pulse occurs.

### Scaler Operation

Initially assume that the reset button has been depressed and that the scaler selector switch is set to 1. When the reset button is depressed, there is a higher voltage applied to the grid of the first section of each binary scaler causing

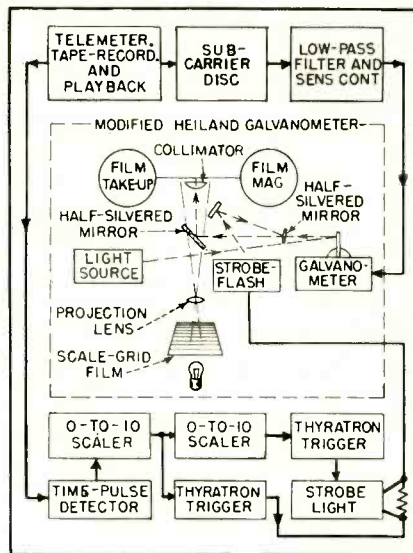

FIG. 2—Block diagram of recorder proper

conduction. When the first scaler flips the second section conducts, producing a negative-going pulse which is transmitted to the second binary scaler. This causes the second scaler to flip and so on until all four binary scalers have flipped.

The negative-going pulse at the output of the last scaler is differentiated and applied to the tuned circuit connected to the grid of the 6J6 feedback tube, producing a damped oscillation at the grid. Since the tube is normally cut off, the first negative swing of the oscillation has no effect. When the oscillation goes sufficiently positive, the tube conducts and the plate voltage drops.

The plate load for this tube consists of the parallel combination of four 6,800-ohm resistors, which are wired to the four decks of the selector switch. The negative-

going signal at the plate is transmitted through the diodes to the grid of the conducting section of all the binary scalers resetting to the original condition wherein all the first sections of the scalers are conducting.

With the scaler selector switch set at 1, there will be a negative-going signal at the output of the last scaler for each input pulse.

### Schmitt Trigger

At the same time the reset is taking place, the negative-going signal at the output of the last scaler is applied to the input of the Schmitt trigger and cathode follower as shown in Fig. 3.

The Schmitt trigger, shown in Fig. 6, provides an output of uniform amplitude and duration. Since the grid of the first section of the trigger is held at a higher potential than the grid of the second section, the potential of the common cathode follows that of the grid with the higher potential. With no signal applied to the input, the first section conducts heavily and the second section is cut off.

When a negative-going signal is applied to the input of the trigger, the plate potential of the first section increases, the cathode potential decreases and the second section starts to conduct. The regeneration continues until the first section is cut off and the second section is conducting heavily.

The trigger remains in this condition as long as the grid of the first section is held negative by the input. Once the input goes sufficiently in the positive direction, the first section starts to conduct, the regenerative cycle reverses and the first section is then conducting and the second cut off.

Since the input signal is differentiated, the signal applied to the input grid is a short negative pulse. The output, taken from the plate of the second section, is therefore a short negative pulse which is fed to a dual cathode follower providing identical outputs. One output is fed to the next scaler and the other is fed to the strobe trigger.

### Strobe Trigger

Figure 7 shows the strobe thyatron trigger.

A minor time line is produced

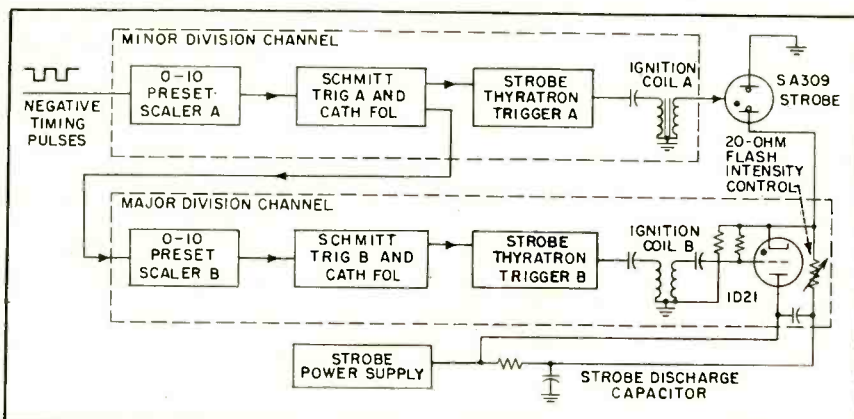

FIG. 3—Time-grid generator and strobe tube circuits utilize standard circuit elements





major time line starting with the first pulse from the *A* scaler for every one to ten minor time lines.

### Template Pantograph

Figure 8 shows a schematic diagram of the optical-mechanical pantograph developed to provide function-scale-grid templates for the data plotter. The mechanical connection between the crosshair cursor and the lens assembly for photographing an image of a slit on the film plane is shown in simplified form.

Mechanical arm *A* is pivoted at point *B* to allow the crosshair cursor to travel from one end of the calibration curve to the other and the lens assembly to travel between mechanical stops. Pivot point *B* is adjustable to accommodate a variety of dimensions in calibration curves.

In the operation of the pantograph, the crosshair cursor is centered upon predetermined intersections of function values and the curve. At each intersection the strobe tube which illuminates the image of a slit is energized, thus photographing a line on the photographic film located at *C*.

The completed function-scale-grid template shown in Fig. 9 has a series of closely spaced lines photographed on the film which represents the function values desired. The incremental spacing of these function-grid lines corresponds to the curvature of the calibration curve as shown in Fig. 10.

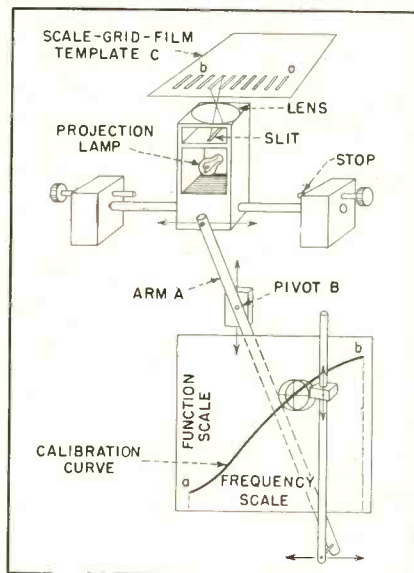

FIG. 8—Schematic diagram of pantograph used in data plotter

The scale-grid lines are constructed from the intersection of the function values and the curve.

Note that in Fig. 9 ten different scales are photographed on one film since only a small vertical image of the template is needed in the recording process. Thus, as many as ten functions can be made available by a simple mechanical detent arrangement in the film holder.

Major and minor divisions are produced on the function-scale template by the same system that was used for producing major and minor timing divisions.

A mechanical counting system of stepping switches is interlocked in such a way that the operator can preset the number of major and

minor divisions to be used. The operator then pushes one button each time a function line is to be photographed and the machine automatically produces a minor grid or major grid line as required.

### Calibration

The calibration procedure used in plotting data from an *f-m/f-m* telemetering system will be described as a detailed example. In this system, the function values are transmitted by a *f-m* subcarrier and the function amplitude is proportional to the frequency of the carrier transmitted.

A calibration curve similar to the one in Fig. 9 is plotted, giving the function to be measured as one coordinate and the frequency as the other coordinate. This calibration curve can include a combination of the transfer characteristics of all of the components in the system. In the particular system being described, the transmitted data are stored on a magnetic tape as the subcarrier frequency. Therefore, the instantaneous frequency at any given time represents a particular function value.

During calibration, a specific frequency is recorded onto the calibration tape. Two or three different values of frequency may be used to give a two or three-point calibration. Each calibrating frequency can be related to a specific function value from the calibration curve; therefore the calibration point becomes a frequency analog

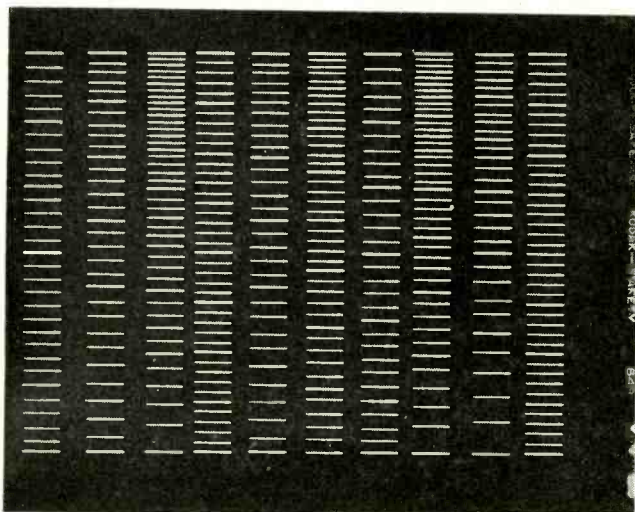

FIG. 9—Typical function-scale-grid template has ten different scale grids on same piece of film

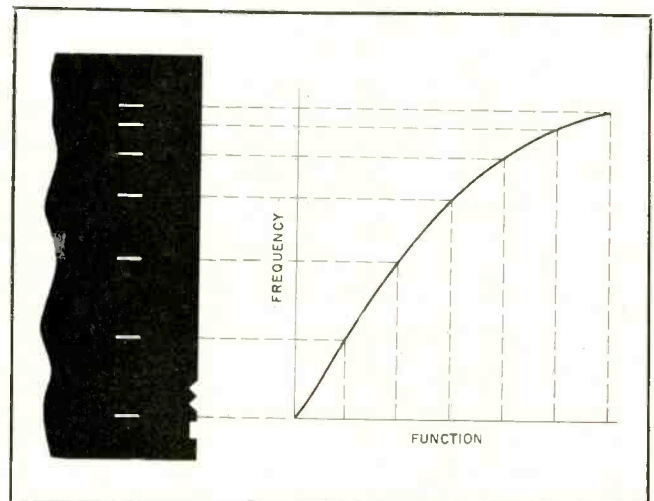

FIG. 10—Calibration curve (right) illustrates construction of scale-grid template (left)



of the function value to be calibrated.

In the case of a voltage-controlled, f-m subcarrier oscillator, this calibration frequency can be considered as an analog of the input voltage and again related to a specific function value in cases where the transducer output is a voltage. These calibration frequencies are played back from the magnetic-tape storage through the playback demodulation equipment which is connected to the recording galvanometer.

Calibration points are of sufficient length to allow adequate time for the sensitivity and zero adjustments.

### Pantograph Operation

The operation of the calibration-curve pantograph is simple and straightforward. The calibration curves are prepared on standard 8½ by 11 or 10 by 15-inch graph paper. Ozalid copies of original curves may also be used. The function values to be transferred to the calibration-curve templates are determined and indicated on the curve so they can be easily recognized under the crosshair cursor.

The ratio between major and minor divisions is decided upon and programmed onto the counting circuits; the center line between the extreme ends of the calibration curve is marked to enable accurate placement of the curve on the plotting table. The operator then checks to see that the crosshair cursor will traverse the curve from one end to the other accurately while the lens assembly moves from one mechanical stop to the other.

After the film has been loaded into the camera, the operator starts at one end of the calibration curve and intersects each function point to be transferred to the film. At each point the strobe-flash tube is energized to photograph the function-grid line at that point.

Since as many as ten functions may be placed on one film, an adequate identification system must be used. One simple method is to identify the film itself and also to identify the number of the function-grid position with the particular function used in the calibration curve. The detent positions in

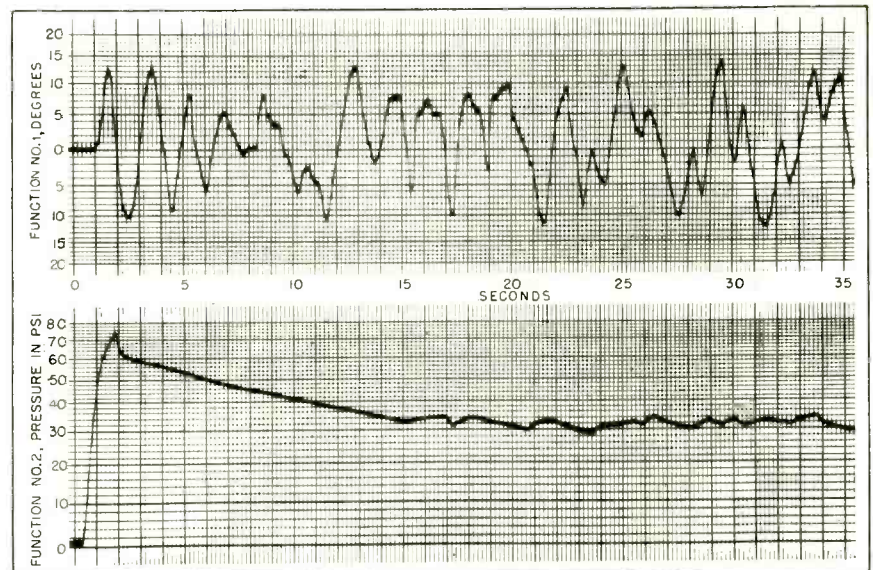

FIG. 11—Typical data plots made simultaneously on SADAP show degrees (top) and pressure in psi (bottom). Horizontal time scale is in seconds

the film holder are numbered for this purpose.

A system to identify the film itself for a particular group of functions has been worked out, involving the use of a standard ink pen with India ink. In the dark-room the title is written with India ink directly on the emulsion side of the film. The area immediately around the writing is then exposed to a small amount of light. This identification is done prior to its insertion in the film holder. During subsequent photographic processing, the ink washes off, leaving its image in the silver emulsion.

After the film has been properly exposed in the calibration curve pantograph, the film is processed in a photographic reversal bath to obtain an opaque background with transparent grid lines.

### Evaluation

To complete the manual data reduction for a single missile flight in a reasonable time, approximately one week, it is most efficient for a large number of people to coordinate their efforts in some sort of a production-line effort. As a typical example, it takes approximately 15 to 20 people, working an 8-hour day, approximately one week to complete the data reduction of 20 to 25 telemetered functions. This involves 600 to 800 man-hours for a typical flight-length time of about 120 seconds.

The simplified automatic data plotter yields a complete set of data, involving approximately twenty functions plotted as function against time, in approximately 10 hours. This time includes making the scale grid templates, photographic processing and annotation.

Experience has shown that one man can efficiently operate this equipment. Thus, a ratio of 1:60 is obtained in manpower saving and a significant improvement is obtained in the time required.

### Application

In f-m/f-m systems there are often a number of transducers, such as inductance gages and other electro-mechanical coupling devices, which have a nonlinear transfer characteristic. The simplified automatic data plotter is particularly useful in plotting such data, utilizing the feature of the nonlinear scale grid.

Figure 11 shows a typical data plot produced by the plotter. Even when the transfer characteristic is linear, the ability to change from one scale grid to another, thus obtaining different relations between minor and major divisions, is an extremely useful feature. In addition, this device provides an easy method for applying a scale grid to photographic film, thereby utilizing the high writing speeds of an optical galvanometer.

# Amplifier Selectivity Curves

By RONALD L. QUANDT and JACK SANDERS

Airborne Systems Laboratory  
Hughes Aircraft Company  
Culver City, California

**SUMMARY** — Curves and nomograph determine relative attenuation at points on response curve relative to gain and midband response. Design parameters for amplifier having specified response can be determined

**I**N THE DESIGN of flat-staggered multiple-stage bandpass amplifiers, it is often necessary to determine the relative attenuation of points in the amplitude-frequency response with respect to unity gain at midband. Conversely, it is often desired to find the design parameters of a

flat-staggered bandpass circuit having a prescribed attenuation or gain at specific frequencies.

The curves shown here are useful for obtaining rapid, graphical solutions to many such problems. The nomograph in Fig. 1 is useful for quickly computing the parameter  $X$  used in

the curves. It is also useful for finding the frequencies corresponding to a given attenuation once  $X$  and the circuit  $Q$  have been determined. Cascaded  $N$ -uple stages are presumed here to have the same  $f_0$ . It should be noted that  $X = 1$  at the half-

(continued on p. 190)

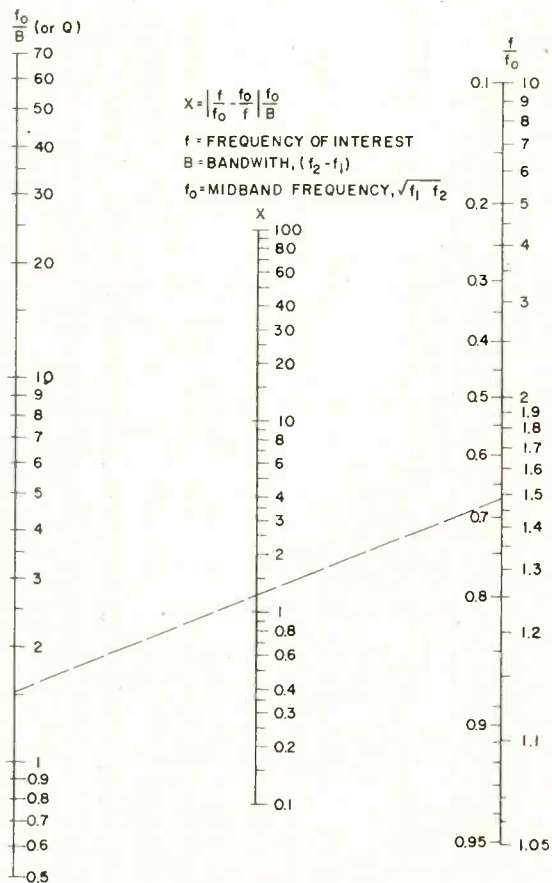

FIG. 1—Nomograph for determining value of  $X$

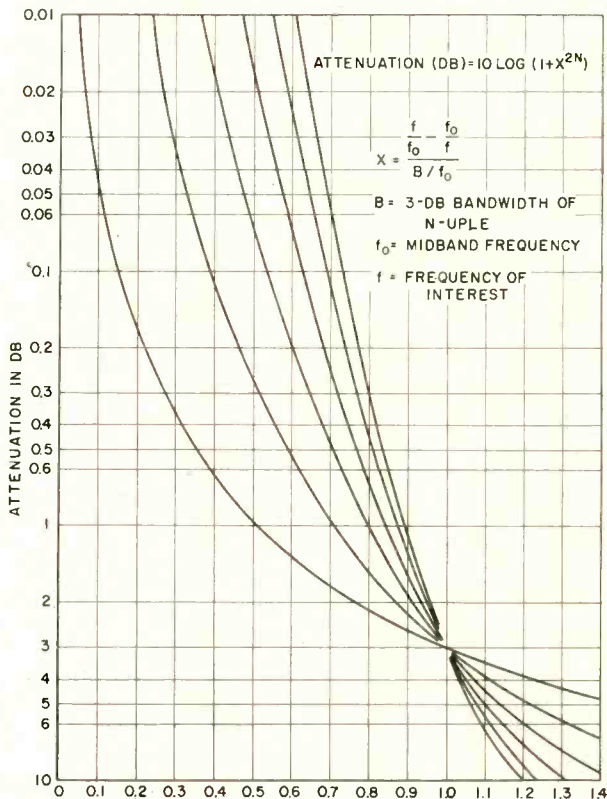

FIG. 3—Selectivity curves for values of  $X$  from 1 to 100





**Cinch**  
ELECTRONIC  
COMPONENTS

DB-25S

# CANNON CONNECTORS

## D SUB-MINIATURE DPA AND DPX SERIES

More than thirty years experience in the design and manufacture of standard electronic components insure Cannon Connectors by CINCH to be of the highest quality materials, fabricated to specifications to maintain consistent quality of product; highest standards throughout all operations.



DB-25P

### D SUB-MINIATURES: STANDARD PIN AND SOCKET INSERTS:

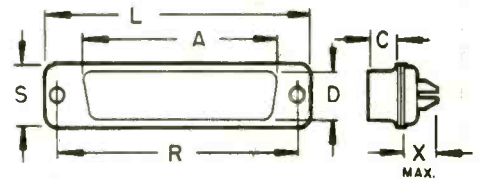

size	A	C	D	L	R	S	X	weight
DA-15P	1 1/4	1 3/4	2 3/4	1 17/32	1.312	3 1/4	3/16	.013
DA-15S	1 1/2	1 3/4	3/16	1 17/32	1.312	3 1/4	3/16	.014
DB-25P	1 1/16	1 3/4	2 3/4	2 3/4	1.852	3 1/4	3/16	.023
DB-25S	1 33/64	1 3/4	3/16	2 3/4	1.852	3 1/4	3/16	.031
DC-37P	2 13/64	1 3/4	2 3/4	2 23/32	2.500	3 1/4	3/16	.035
DC-37S	2 11/64	1 3/4	3/16	2 23/32	2.500	3 1/4	3/16	.035
DD-50P	2 7/8	1 3/4	1 5/32	2 3/8	2.406	3 3/4	3/16	.035
DD-50S	2 3/4	1 3/4	2 7/8	2 3/8	2.406	3 3/4	3/16	.040
DE-9P	4 3/4	1 3/4	2 3/4	1 13/64	.984	3 1/4	3/16	.011
DE-9S	4 1/4	1 3/4	3/16	1 13/64	.984	3 1/4	3/16	.012

FRACTIONS ±1/4 Tolerance      DECIMALS ±0.005 Tolerance

### D SUB-MINIATURE SPECIFICATIONS:

Shell, including flange — steel or brass; Finish — Cadmium plate or Iridite. Contacts — No. 20, 5 ampere rating — Copper base alloy, gold plate finish.

Insert arrangements — 5 plus coaxials in 9, 15, 25, 37 and 50 contacts.

Insulation material — Zytel 101 or DIALL.

Polarization — Keystone cornered shell.

Operating temperature —67° to +310°F.

Send for illustrated Catalog No. 157 with details of "D" Sub-Miniature, "DPA" and "DPX" Series.



DPA 32-34P



DPA 32-33S

### DPA CONNECTORS:

Shell with retaining plate. Pin and Socket Inserts.

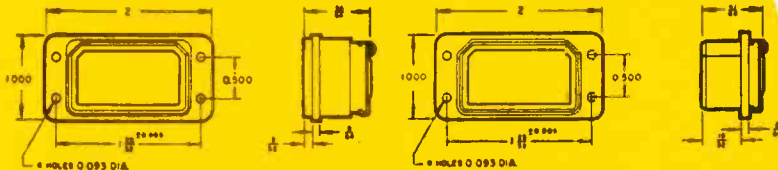

DPX 23-34P



DPX 23-33S

### DPX CONNECTORS:

Split shell. Pin and Socket Inserts.

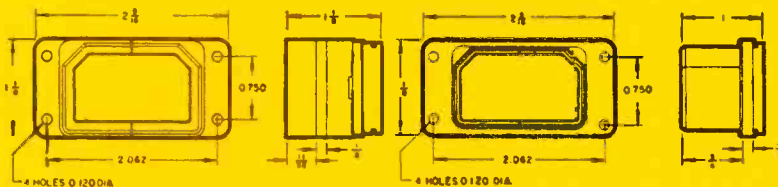

For your connector requirements—you can depend on CINCH.

Centrally located plants at Chicago, Illinois; Shelbyville, Indiana; LaPuente, California; St. Louis, Missouri.

★ Manufactured by Agreement with Cannon Electric Company



**Cinch**  
ELECTRONIC  
COMPONENTS

## CINCH MANUFACTURING CORPORATION

1026 South Homan Ave., Chicago 24, Illinois.  
Subsidiary of United-Carr Fastener Corporation, Cambridge, Mass.

(continued from p 188)

power frequencies,  $f_2$  and  $f_1$ .

For cases where the deviation of the frequency of interest  $f$  from the midband frequency of an amplifier,  $f_0$ , is small compared to  $f_0$ ,  $X$  may be determined from  $X \approx |f - f_0| / (B/2)$ .

### Examples

An amplifier is to be designed having a midband frequency,  $f_0$ , of 40 mc. Its overall bandwidth,  $B_0$ , is to be 26 mc. What is the lowest order  $N$ -uple that can be used if it is desired to attenuate a 26.9-mc signal by 8 db with respect to  $f_0$ ?

Overall  $Q$  of the amplifier is  $Q_0 = f_0/B_0 = 40/26 = 1.54$ . At the frequency of interest, 26.9 mc,  $f/f_0 = 26.9/40 = 0.672$ . From Fig. 1, find  $X = 1.26$ , corresponding to  $Q_0 = 1.54$  and  $f/f_0 = 0.672$ .

From the Fig. 2, opposite  $X = 1.26$ , find an attenuation of 7 db for  $N = 3$  and 8.7 db for  $N = 4$ . Therefore, a quadruple must be used.

An amplifier consists of three identical, flat-staggered pairs in cascade. If each pair has a bandwidth  $B_2$  of 10 mc, what is the overall bandwidth  $B_0$  of the amplifier; what are its upper and lower half-power frequencies,  $f_2$  and  $f_1$ , respectively and what is the total attenuation of a signal at 60 mc with respect to a signal at  $f_0 = 40$  mc?

At the half-power frequencies of the amplifier, each pair contributes one-third of 3 db or 1-db attenuation. From the curves for a pair  $N = 2$  and an attenuation of 1 db,  $X = 0.71$ . The value of  $X$  so determined, for cascaded identical  $N$ -uples is numerically equal to the bandwidth shrinkage factor of the amplifier. Hence, the overall bandwidth is,  $B_0 = XB_2 = (0.71)(10 \text{ mc}) = 7.1 \text{ mc}$ . Next determine overall  $Q_0 = f_0/B_0 = 40/7.1 = 5.63$ . From the nomograph, corresponding to  $Q_0 = 5.63$  and  $X = 1$ , find  $f/f_0 = 1.093$  and 0.914. Since  $f_0 = 40$  mc, it follows that  $f_2 = (40)(1.093) = 43.7 \text{ mc}$  and  $f_1 = (40)(0.914) = 36.6 \text{ mc}$ .

Determine  $Q_2$  ( $Q$  of a pair);  $Q_2 = f_0/B_2 = 40/10 = 4$ . At the frequency of interest, 60 mc,  $f/f_0 = 60/40 = 1.50$ . From the nomograph, corresponding to  $Q_2 = 4.0$  and  $f/f_0 = 1.50$ , find  $X = 3.33$ . From the curves, find the attenuation per pair ( $N = 2$ ), corresponding to  $X = 3.33$ . It is equal to 21.1 db.

An amplifier is to be designed using a flat-staggered quintuple ( $N = 5$ ) cascaded with a synchronously tuned stage ( $N = 1$ ). The overall bandwidth,  $B_0$ , must be 20 mc. If the quintuple has a bandwidth,  $B_5$ , of 22 mc, what is the bandwidth  $B_1$  required of the synchronously tuned stage

and at what frequencies will the attenuation of a signal be 40-db below that of  $f_0 = 40$  mc?

Determine  $Q_0$  (overall  $Q$ ) of the amplifier  $= f_0/B_0 = 40/20 = 2$ . From the nomograph, find one of the normalized overall, amplifier half-power frequencies, say  $f_2/f_0$ , corresponding to  $Q_0 = 2$  and  $X = 1$ ,  $f_2/f_0 = 1.282$ .

Determine  $Q_5$  ( $Q$  of the quintuple)  $= f_0/B_5 = 40/22 = 1.82$ . From the nomograph, find  $X_5$  ( $X$  for the quintuple)  $= 0.91$ , corresponding to  $f_2/f_0 = 1.282$  and  $Q_5 = 1.82$ . From the curves for a quintuple ( $N = 5$ ), opposite  $X_5 = 0.91$ , find the attenuation of the quintuple to be 1.4 db.

At the half-power frequencies of the composite amplifier, the attenuation contributed by both the synchronous and the quintuple)  $= f_0/B_0 = 40/22 = 1.82$  db. Hence, the attenuation at those frequencies due to the synchronously tuned stage alone must be equal to 3.0 db - 1.4 db = 1.6 db.

From the curves, find  $X_1$  ( $X$  for the synchronous stage)  $= 0.67$ , corresponding to an attenuation of 1.6 db in the synchronously tuned stage ( $N = 1$ ).

From the nomograph, find  $Q_1$  ( $Q$  of the synchronous stage) to be equal to 1.33, corresponding to  $X_1 = 0.67$  and  $f_2/f_0 = 1.282$ . The bandwidth of synchronously tuned stage  $B_1$  may then be determined to be  $B_1 = f_0/Q_1 = 40/1.33 = 30$  mc.

From the nomograph, choose a value of  $f/f_0$  and find  $X_1$  and  $X_5$  corresponding to  $Q_1$  and  $Q_5$  above. From the curves and these  $X$ 's, find the attenuation of each amplifier separately. When added, the sum of these attenuations in db is the overall attenuation of a signal at the chosen frequency relative to one at  $f_0$ . Find, by trial and error, that when  $f/f_0 = 1.78$  and 0.562, the attenuation of a signal at those frequencies is 40-db below a signal at  $f_0$ . The corresponding frequencies are thus  $f = (40)(1.78) = 71.2$  mc and  $(40)(0.562) = 22.5$  mc.

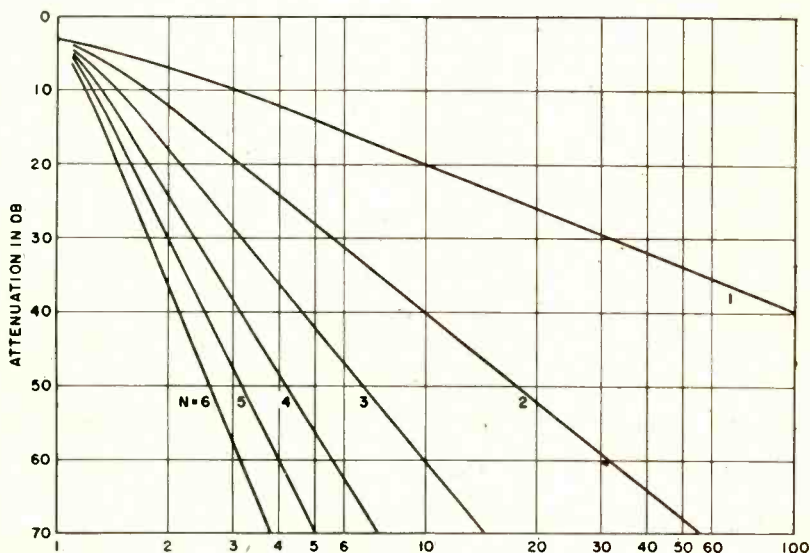
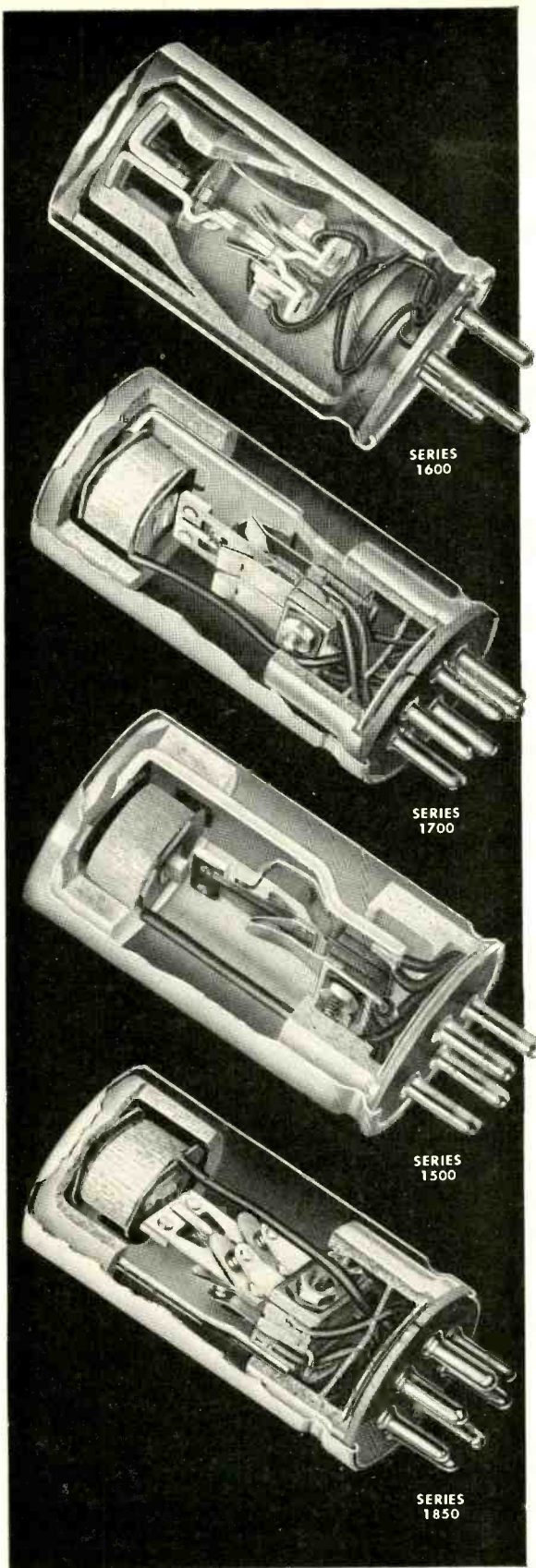

FIG. 3—Selectivity curves for values of  $X$  from 0 to 1.4



# Inside these New Mallory Vibrators...

*New performance  
for your power supply*



New advances in contact design—based on more than a quarter century of Mallory pioneering in the vibrator field—give today's Mallory vibrators even better performance than ever.

Count on these new Mallory models for up to 100% longer life... for faster starts... for extremely low mechanical hum... for greater consistency of output throughout their life. Arcing, erosion, contact transfer and variations in spacing have been greatly reduced. Heat dissipation is higher.

A complete series of models, incorporating new ideas in contact technology, covers practically any vibrator power supply requirements you may have for new equipment on your drawing boards. Check the table shown here, and call a Mallory vibrator specialist for a consultation on your application.

	Series	Description	Applications
Interrupter types	1600	light to medium duty, shunt drive	automotive, electronics
	1500	medium to heavy duty, separate drive	communications, electronics
	1700	heavy duty, separate drive, split reed	communications, electronics
	1750	heavy duty, separate drive, duplex operation	communications, electronics
Self-rectifying types	1800	nominal duty, shunt drive	electronic equipment—
	1850	nominal duty, separate drive	for high efficiency, small space

#### Serving Industry with These Products:

**Electromechanical** — Resistors • Switches • Tuning Devices • Vibrators  
**Electrochemical** — Capacitors • Mercury and Zinc-Carbon Batteries  
**Metallurgical** — Contacts • Special Metals • Welding Materials

Parts distributors in all major cities stock Mallory standard components for your convenience.

**Expect more... get more from**



**See us at Wescon... The Mallory Booth is 1312**





it's

first in  
Performance  
Reliability  
and Quality

Kepeco

# FOR VOLTAGE REGULATED POWER SUPPLIES

## KR SERIES



1.5 Amp.  
**KR**  
SERIES

MODEL  
KR-16MC

OUTPUT VOLTS DC	6.3V AC	Model	Rack Mount			Price
			W	H	D	
0-150	Each supply	KR16	19"	12½"	17"	\$625
100-200	has two	KR17	19"	12½"	17"	\$625
195-325	15 Amp.	KR18	19"	12½"	17"	\$695
295-450	outputs	KR19	19"	12½"	17"	\$695

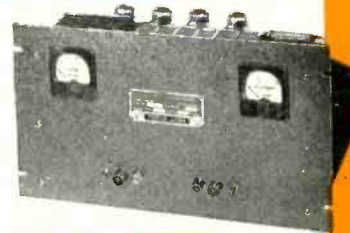

600 ma.  
**KR**  
SERIES

MODEL KR-8M

OUTPUT VOLTS DC	6.3V AC	Model	Rack Mount			Price
			W	H	D	
0-150	Each supply	KR 8	19"	10½"	13"	\$330
100-200	has two	KR 5	19"	10½"	13"	\$240
195-325	10 Amp.	KR 6	19"	10½"	13"	\$240
295-450	outputs	KR 7	19"	10½"	13"	\$250

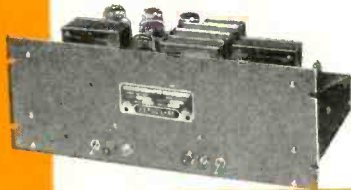

300 ma.  
**KR**  
SERIES

MODEL KR-4

OUTPUT VOLTS DC	6.3V AC	Model	Rack Mount			Price
			W	H	D	
0-150	Each supply	KR 12	19"	7"	11"	\$270
100-200	has two	KR 3	19"	7"	11"	\$180
195-325	5 Amp.	KR 4	19"	7"	11"	\$180
295-450	outputs	KR 10	19"	7"	11"	\$190



125 ma.  
**KR**  
SERIES

MODEL KR-1C

OUTPUT VOLTS DC	6.3V AC	Model	Rack Mount			Price
			W	H	D	
0-150	Each supply	KR 11	19"	7"	11"	\$180
100-200	has one	KR 1	19"	7"	7½"	\$ 90
195-325	3 Amp.	KR 2	19"	7"	7½"	\$ 90
295-450	output	KR 9	19"	7"	7½"	\$ 97

To Include 3" Current and Voltage Meters, Add M to Model number (e.g. KR 16-M) and Add \$30.00 to the Price.  
To Include Dust Cover and Handles for Table Mounting, Add C to Model number (e.g. KR16-C) and Add \$10.00 to the Price.  
To Include Meters, Dust Cover and Handles, Add MC to Model number (e.g. KR-16 MC) and Add \$40.00 to the Price.

PRICES F.O.B. Flushing.

### ★ FAST RECOVERY TIME    ★ GOOD STABILITY    ★ LOW OUTPUT IMPEDANCE

Kepeco **KR** Voltage Regulated Power Supplies are conservatively rated and are designed for continuous duty at 50°C ambient.

**REGULATION:** Less than 0.2 volts for line fluctuation from 105-125 volts and less than 0.2 volts for load variation from 0 to maximum current.

**RIPPLE:** Less than 3 mv. rms.

**STABILITY:** The output voltage variation is less than the regulation specification for a period of 8 hours.

**RECOVERY TIME:** Less than 50 microseconds. The excursion in the output voltage during the recovery period is less than the regulation specification.

**OUTPUT IMPEDANCE:** Less than 0.1 ohms from 20 cycles to 100KC. Less than 0.5 ohms from DC to 20 cycles. Many units have very much lower output impedance.

featuring

- Fast recovery time, suitable for square wave pulsed loading.
- Voltage range continuously variable without switching.
- Either positive or negative may be grounded.
- Advanced vacuum tube regulator circuitry.
- Power requirements 105-125 volts, 50-65 cycles.
- Locking type voltage control AC, DC switches, fuses, and pilot lights.
- Terminations on rear of unit.
- Oil filled condensers.
- Color Grey Hammerstone.
- Guarantee one year.

All models available for 400 cycle operation on special order.

SEND FOR BROCHURE B-576 — SPECIFICATIONS ON NEW MAGNETIC, TRANSISTOR AND TUBE VOLTAGE REGULATED POWER SUPPLIES AND SEMI-CONDUCTOR DC TO DC CONVERTERS



## KEPECO LABORATORIES, INC.

131-38 SANFORD AVENUE • FLUSHING 55, N.Y. • INDEPENDENCE 1-7000

Visit Booths #808-809 • WESCON SHOW • AUGUST 20-23 • SAN FRANCISCO

mm with better signal-to-noise ratio than would be obtained using two half-tracks; and combination magnetic and photographic prints for 35-mm theatrical release so that the same prints can be used whether or not a given theatre is equipped for magnetic sound. At present this can be accomplished only by sacrificing some of the picture area to make room for the

photographic sound track. Conceivably, it would be possible to have just as many photographic tracks as magnetic tracks without increasing space requirements.

George Lewin, Chief of Pictorial Engineering at the Army Pictorial Center, described the work outlined above at a recent New York panel discussion on sound recording co-sponsored by the SMPTE.

## Magnetic Core Coincidence Circuit

By A. L. FREEDMAN  
Ericsson Telephones Ltd.  
Beeston, Nottingham  
England

A MAGNETIC CORE coincidence circuit is obtained by connecting the output windings of two square loop cores in parallel, as shown in Fig. 1. With both cores initially saturated in the same sense, a current pulse applied to the input winding of one of the cores will not cause the core to change state because its output winding is short circuited by the output winding of the other core. If input pulses are applied to both cores, both will switch, generating an output signal on the common output winding. An output signal is also obtained when the cores are simultaneously switched back to the initial state by a pulse applied to a reset winding on each core.

Circuits based on this principle have been investigated using 3 mm Mullard D cores which require one ampere-turn to change state. In the coincidence circuit, however, an input signal as large as 1.85 ampere-turns can safely be applied to either core without causing switching, so that the circuit operates correctly for input signals in the range 1 to 1.85 ampere-turns.

The way in which this tolerance arises is as follows: Assume that an input current is applied to core A in Fig. 1, both cores being in the zero state. Current generated in the output windings of core A is in such a direction as to tend to switch core B into the one state. As long as the ampere-turns applied to core A are less than twice the minimum switching ampere-turns, the excess current passed by core A to core B is not enough to switch core B. The latter remains on the horizontal part of its hysteresis loop, short-circuits core A and prevents it from switching. When an input current generating at least twice the minimum switching ampere-turns is applied to the input winding of core A, both cores switch and the circuit no longer acts as a coincidence circuit.

This analysis is confirmed by

## Spot Wobble Cuts TV Screen Lines

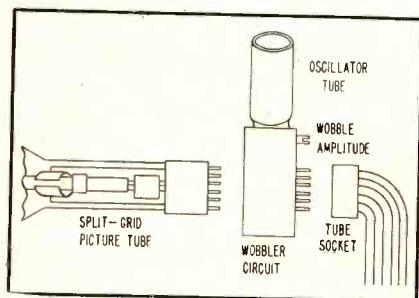
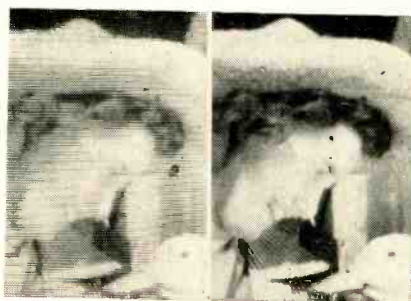

FIG. 1—Wobble oscillator mounts conveniently at base of crt. Short leads minimize stray r-f radiation



Photos of the same crt screen without spot wobble (left) and with proper wobble adjustment (right).

AVERAGE tv viewing distance is the point at which the viewer just fails to distinguish individual horizontal lines. With a 24 in. picture tube, this distance is about eleven feet. This normal viewing distance can be reduced to six feet through the use of spot wobbling.

Spot wobbling, in effect, lengthens the beam vertically so that adjacent lines are just tangent. The horizontal dimension of the beam, on which the resolution depends, is left unchanged. The spot must be wobbled at a frequency sufficiently

high that individual cycles of wobble are not visible.

**SPLIT GRID**—A new crt, developed by Westinghouse, allows wobbling without the extra deflection coils required by a system developed in Britain. The electron gun is a low-voltage electrostatic type with the cylindrical focus electrode cut in half along a horizontal plane.

The oscillator used to produce the wobble is mounted at the base of the crt where all operating voltages are available, as shown in Fig. 1. The oscillator circuit of Fig. 2 drives the split grid at about 25 mc. The low capacitance of the split grid allows high wobble frequencies to be easily obtained. The oscillator coil consists of 11 turns of No. 17 wire on a 3/4-in. diameter form.

The oscillator-split grid combination has a high  $Q$ , minimizing driving power and reducing oscillator harmonics. The mounting keeps leads short preventing r-f radiation. No interference effects due to oscillator harmonics have been noted.

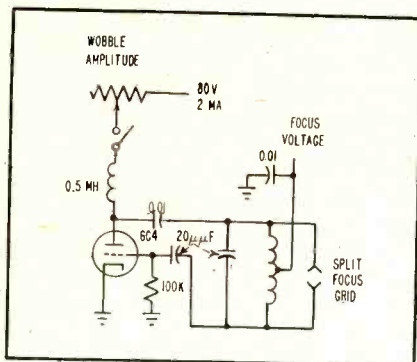
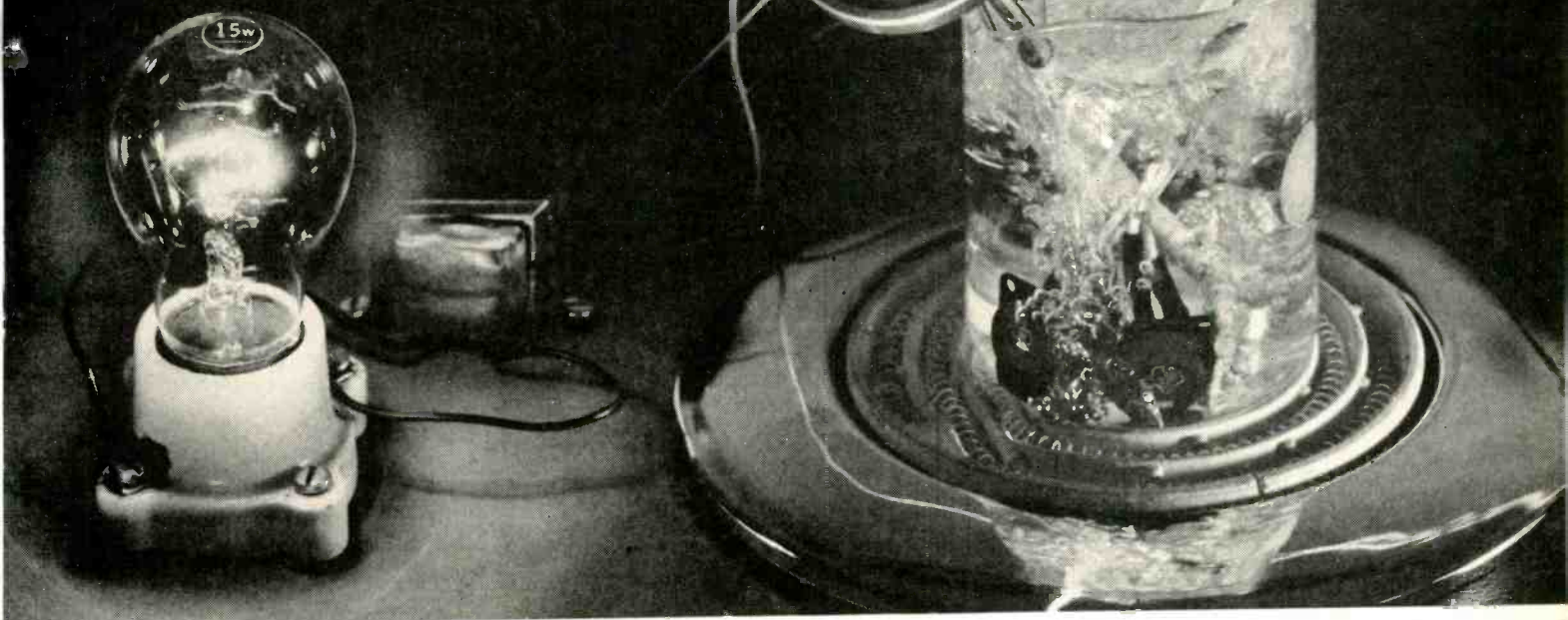

FIG. 2—Oscillator drives split focus grid at 25 mc, causing the beam to widen vertically



SILICON  
POWER  
TRANSISTORS



now you can get

**15 watts at 100°C**



**NEW silicon high power transistor**

For your audio servo uses — and many other applications, you can reach new transistor highs — in power, temperature and gain with low distortion and the stability and reliability you expect from silicon transistors. In Class B push-pull operation, two new TI Type 2N389 silicon diffused junction transistors provide 15 W power output at 100°C ... with distortion of less than 10% and typical beta cutoff frequency of 300 kcps. This new transistor is the first high power silicon transistor and the latest addition to the TI silicon line ... widest in the industry.

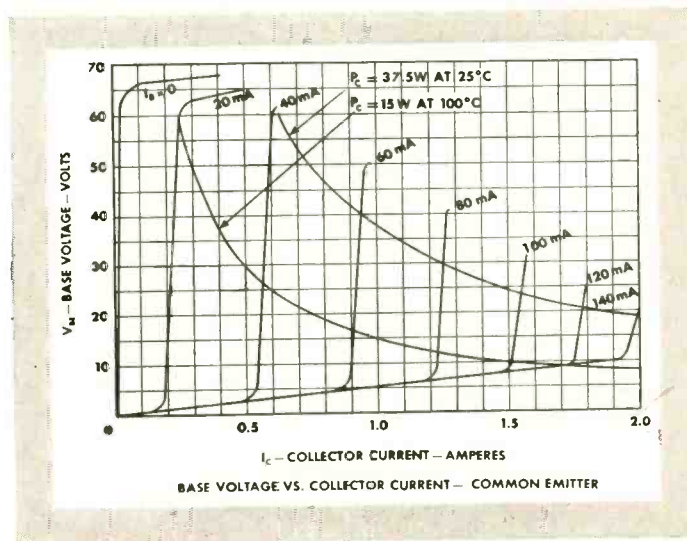

**absolute maximum ratings**

Power Dissipation at 100°C	15 Watts
25°C	37.5 Watts
Collector to Emitter Voltage	+60 Volts
Base to Emitter Voltage	-2 Volts
Collector Current	2 Amperes
Saturation Resistance	6 Ohms
Base Current	0.5 Ampere
Storage Temperature	-65 to +150° C

visit our booths  
no. 3001, 3002, 3019, 3020  
at the 1957 wescon show



**TEXAS INSTRUMENTS**  
INCORPORATED  
POST OFFICE BOX 312 · DALLAS 21, TEXAS

the fact that a three-core, three-input coincidence gate was found to operate correctly for input pulses 1 to 1.4 times the minimum switching ampere-turns.

The coincidence circuit can, of course, be used as an and-gate for simultaneous inputs. Such an and-gate, is shown in Fig. 2A. The 36-ohm resistor is used to reduce the output generated when both cores switch to that obtained when transferring from a single core. When compared with the or-gate of Fig. 2B it is seen that while in the latter the output windings are connected in series, in the and-gate they are connected in parallel. This is the dual of relays.

The author acknowledges the permission of the Controller of Research of Ericsson Telephones Ltd. to publish this material.

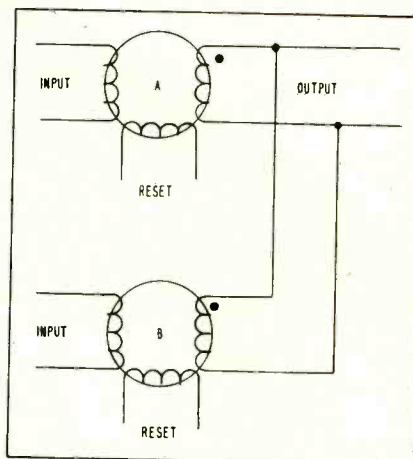
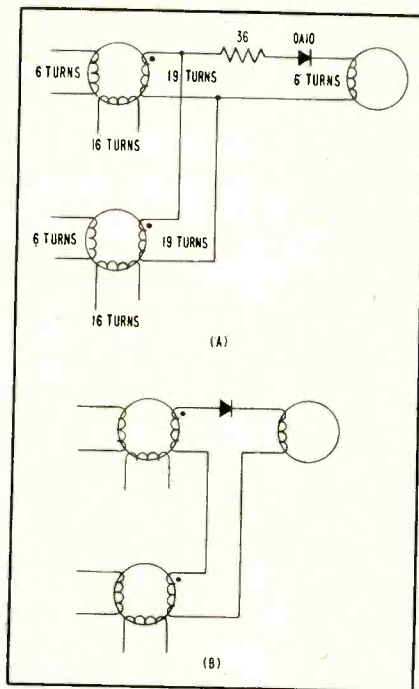

FIG. 1—Basic coincidence circuit using two magnetic cores generates signal on common output when inputs are excited

FIG. 2—Coincidence circuit used as an and gate (A) and as an or gate (B) has output parallel and series

## Silicon Diodes as Logarithmic Elements

Y. GOLAHNY  
Raytheon Manufacturing Co.  
Waltham, Mass.

LOGARITHMIC converters are useful in instrumentation associated with signals of a wide dynamic range, in mathematical computation, and in

automatic gain control systems such as used for signal compression and expansion.

Linear-to-logarithmic scale conversion may be obtained by many techniques including thermionic diodes with negative anodes, vari-

able- $\mu$  tubes and application of feedback in amplifiers, contact rectifiers, special potentiometers and photomultiplier tubes. Practical shortcomings of these devices include range and accuracy limitations, input and output coupling difficulty and cost.

An inexpensive linear-to-logarithm converter with reasonable range and accuracy, utilizing available stock diodes, may have an advantage over these devices.

A diode will approximate logarithmic characteristics in the lower range of its volt-ampere characteristic curve. As the current through the diode increases, the logarithmic approximation improves, until the current is large enough to cause a significant deviation from the logarithmic current-voltage relation. The upper limit of the logarithmic range was found to be approximately 1 ma.

The logarithmic characteristics of some diodes were explored by measuring their current-voltage relation in ranges from 0.5, 1.0 and 2 ma to 5, 10, and 20 uua. An accurate analysis was obtained by comparing the voltage increments for each diode. Table I summarizes

Table I—Diode Logarithmic Conversion Characteristics

Type	No. tested	Number of Decades						Temp C	Direction
		2	3	4	5	6	7		
IN300	2			2				25	Forward
IN300A	23		1	6	6	5	4	25	Forward
	6		1	2	2	1		75	Forward
	2							25	Reverse
	6							75	Reverse
IN305	5							75	Forward
	6							75	Reverse
IN432	5		2		3			75	Forward
	5							75	Reverse
Exp 7	30	1	3	7	11	4	3	25	Forward
	15		7	3	1	2		25	Reverse
Exp 8	25	3	7	7	7	1		25	Forward
	24		2	13	7	1		40	Forward
	24	6	9	2				40	Reverse
IN460	5			2	3			75	Forward
	5							75	Reverse
CK840	10			6	3			25	Forward



# IT'S ROUND-UP TIME AT AMP

... products for your **ELECTRONICS**  
and **AVIONICS** applications

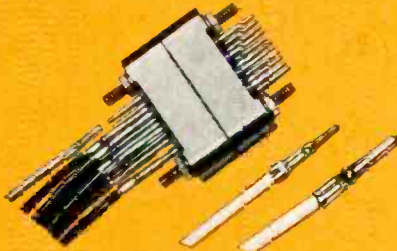

## TAPER PINS

The A-MP Miniature Taper Pin Receptacle eliminates tedious and costly operations of soldering leads to miniature connectors. This solderless, quick-disconnected terminal is applied to the lead by means of A-MP Automachine and A-MP Certi-Crimp Tooling... then capped over other type connectors, modified to receive the A-MP 37 Series Miniature Taper Pin Receptacle.

Other A-MP Taper Pins are available (Series 53 and 88) for wire sizes 24 - 12 AWG and a wide range of insulation sizes. Insulation piercing Taper Pins are available for small stranded wires and popular size tinsel cords.

## TAPER TAB RECEPTACLES



A-MP Taper Tab Receptacles are a recent development for flat tabs employing the taper key principle. They are available for wire sizes 24 - 18 AWG, in gold, silver and tin plated finishes.

The tapered section of these receptacles is standardized to fit the same size tapered tab. Insulation piercing Taper Tab Receptacles are available for small wire sizes and tinsel cords.



## CONNECTORS FOR PRINTED CIRCUITS

The AMP-Edge Connector is design-engineered with positive wiping contact and frictional grippage. This connector gives you: greater flexibility... its size does not limit the size of your completed unit; design versatility... easily applied, in any arrangement, to any section of the perimeter; costs reductions... in applying connector to the wire and to the printed circuit.

The AMPin Connector... gets leads to the printed circuit in one assembly operation... eliminates your investment in expensive automation equipment... no loose leads during the solder-dip process... construction promotes good capillary flow of solder during dipping process... can be applied to solid or stranded wires... is self-retaining and self-aligning.

## THE SHIELDED WIRE TEAM

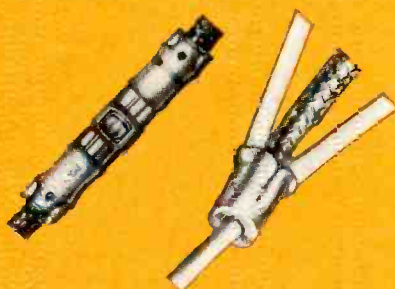

The A-MP Shielded Wire Splice joins sections of shielded wire so that the inner conductor and outer shield are firmly spliced and remain effectively insulated from each other. Features include: rectangular inspection window, in center, permits easy inspection to determine proper placement of ends of inner conductor; inspection ports, at each end, to check proper depth of braid enclosed after crimping; and overhang of outer sleeve projects beyond inner elements and grips braid for anti-vibration support.

The A-MP Termashield Shielded Wire Ferrule are of one-piece construction, is slightly thicker than the wires joined, and is the ideal one-step splice for ground tap accommodation.

This A-MP Shielded Wire Team is color-coded for easy identification of leads and connectors and provides a simple one-step operation that reduces assembly time and costs.

Further information on these products is available on request.

# AMP INCORPORATED

WHOLLY OWNED SUBSIDIARIES: Aircraft-Marine Products of Canada Ltd., Toronto, Canada  
Aircraft-Marine Products (Great Britain) Ltd., London, England  
Societe AMP de France, Le Pré St. Germain, Seine, France  
AMP - Holland B.V., Hertoerbosch, Holland  
DISTRIBUTOR IN JAPAN: Oriental Terminal Product Co., Ltd., Tokyo, Japan

General Offices  
3422 Eisenhower Blvd.  
Harrisburg, Pa.



Visit us at the  
**WESCON SHOW**  
Aug. 20-23, 1957  
Booth Nos. 2319-2320.



**Colorful  
Comfortable**

**Get Kraeuter's  
All New  
"CG" Pliers**

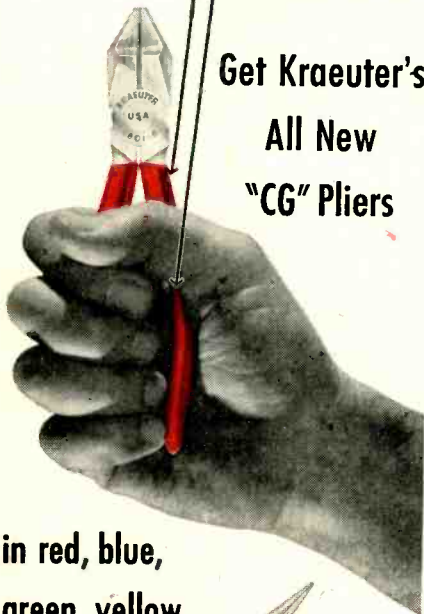

**in red, blue,  
green, yellow  
& orange**



KRAEUTER has done it again. Now for the first time you can secure comfort and color along with KRAEUTER quality at no increase in cost.

Every KRAEUTER solid joint plier has a cushion grip of thick vinyl to make your tough jobs easy. All KRAEUTER "CG" cushion grips provide easy identification—easy to locate in your tool box—ideal for departmental color coding in your plant. All KRAEUTER "CG" cushion grips assure you comfort and ease on the job.

Whether you use side cutters, diagonals, lineman's or one of the other quality pliers in KRAEUTER's long line, you will find "CG" cushion grips a standard feature at regular prices.

Ask your distributor for KRAEUTER "CG's" today and put ease in your work.

\*CG Cushion Gripped Pliers

**BUY THE FINEST  
BUY KRAEUTER  
BUY AMERICAN**

AS MODERN AS TOMORROW

**kraeuter & co., inc**

FOR 100 YEARS THE FINEST IN HAND TOOLS 1860-1960 NEWARK, N. J.

Circle 102 Readers Service Card



the logarithmic conversion characteristics for the diodes investigated. Maximum variation of the current-voltage relationship was specified as 2 db. Conversion factors were 0.08 v per decade in the forward direction and 1.6 v per decade in the reverse direction. A 10-percent voltage tolerance includes measurement errors, electrometer drift and noise.

Diodes IN300A, Exp-7 and Exp-8 yield a substantial proportion of units with good logarithmic conversion characteristics over a range of 7 decades in the forward direction with a conversion factor of 0.08 volts per decade. Thirty Exp-7 type diodes, for example, yielded 3 units with 7 decades, 4 with 6 decades, 11 with 5 decades, 1 with 4 decades, 3 with 3 decades, 1 with 2 decades, and 2 with no decades of logarithmic current voltage relation within 2 db.

An increase in ambient temperature results in a decreased logarithmic range and affects the linear to logarithmic conversion factor. In the reverse direction, the conversion factor of 1.6 v per decade is quite high but the logarithmic range, tolerance and consistency are considerably poorer than in the forward direction.

Diodes such as IN300A, Exp-7 and Exp-8 can be used directly as logarithmic elements. Appropriate circuits, such as a bridge network containing more than 1 diode, and

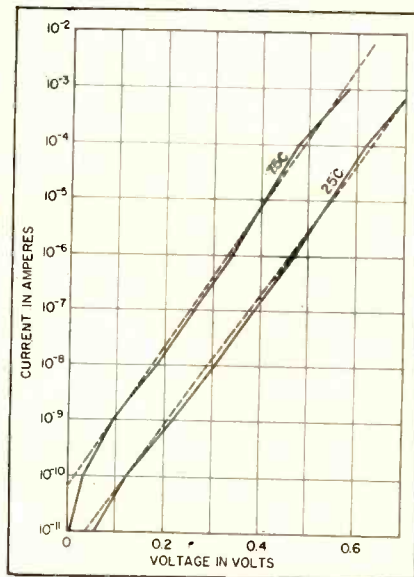

Characteristic of IN300A diode at 25 C and 75 C compared to true logarithmic function (dashed line)

the connection of a number of diodes in series should extend the range of useful logarithmic conversion and increased volts per decade output. The graph illustrates the current voltage characteristics in the forward direction of a IN300A diode, chosen at random, and compared with a true logarithmic function at 25 C and 75 C.

The adverse temperature effects may be reduced by compensating circuits or the enclosure of the diodes in a constant temperature oven similar to the type used for communication crystals.

## Galactic Noise Effects TV Receivers

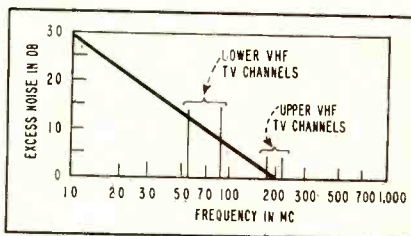

FIG. 1—Galactic noise in excess of thermal equivalent noise as measured by the Bureau of Standards using a vertically polarized dipole

TELEVISION RECEIVER noise factors measured in the laboratory differ from noise factors encountered in actual use since the laboratory measurements fail to take into ac-

count the many external influences affecting the receiver connected to an actual antenna. A more accurate measure of the noise present in a tv system is the effective system noise factor. This takes into account the noise of the antenna, transmission line and the noise from external sources in addition to the receiver noise itself.

In the vhf region, from channels 2 to 6, the predominant external noise is galactic noise. As shown in Fig. 1, it decreases with rising frequency at approximately 7 db per octave.

Figure 2, shows the variation of effective system noise with changes in receiver noise factor, assuming



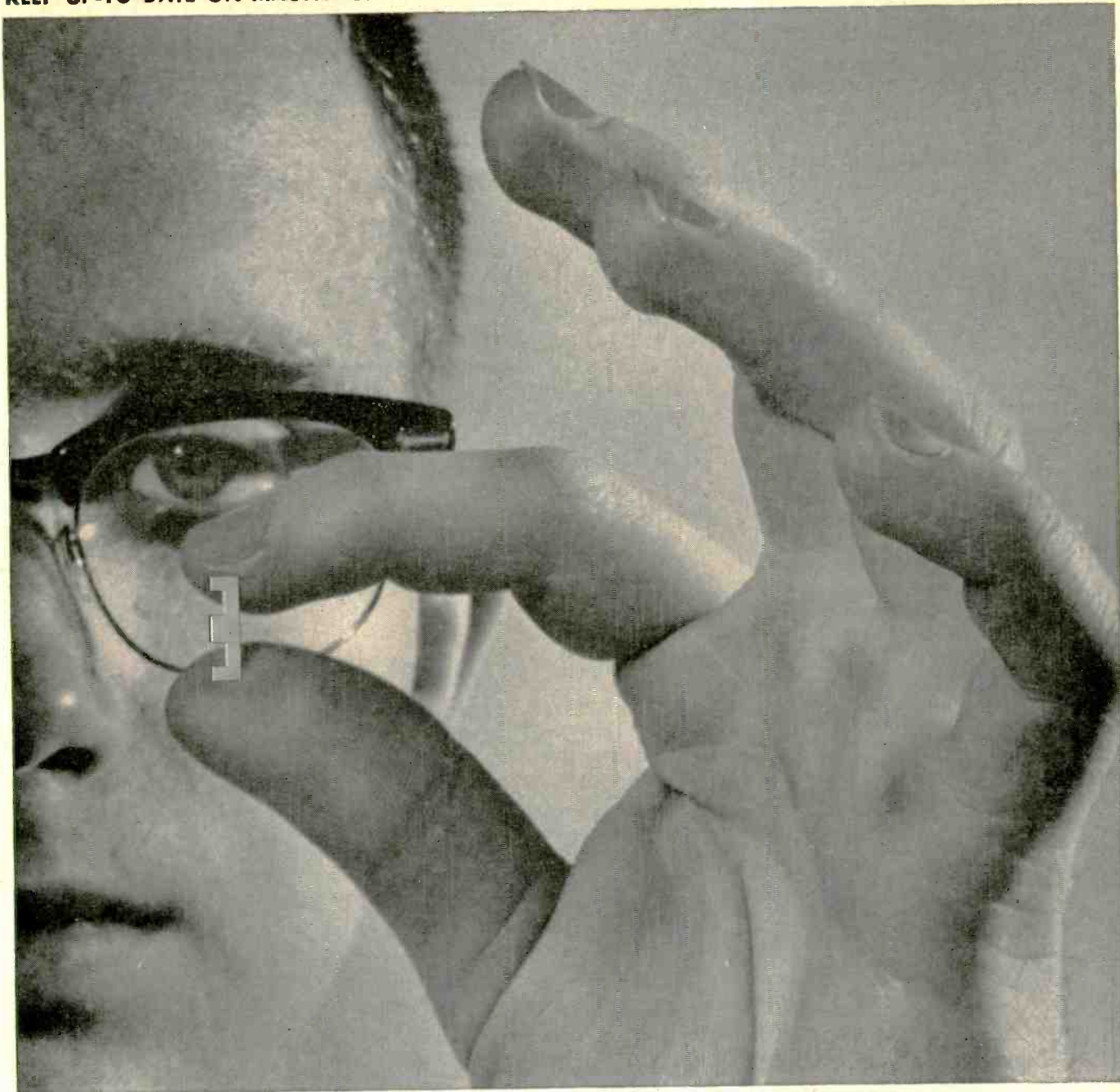

## Here are laminations for miniaturization

If you are making transformers for transistorized or other miniaturized equipment, information about our ultra-small size "performance-guaranteed" laminations can be important news to you. These nickel-iron laminations are produced in standard gauges, and are available in Hy Mu 80, 48 Alloy and, if required, Orthonol.

Dry-hydrogen annealed by our exclusive process, these laminations provide all-important uniform quality. This annealing at a dewpoint of  $-60^{\circ}\text{C}$ . brings our Performance-Guaranteed laminations to ultimate permeability from as little as 5% of that value in the unannealed state.

Like all laminations from Magnetics, Inc., the "miniatures" are packed in standard nine-inch boxes to facilitate handling in your plant, and are immediately available from stock. These features alone provide substantial savings.

Edges of these fine tolerance laminations are cut off squarely and cleanly to minimize air gap where mating parts are butted. Thus, high operating efficiency is insured.

There's no room here for the really detailed story, but for complete information on our "Performance-Guaranteed" magnetic laminations, send for our newest catalog—just published—ML-301. Write today. *Magnetics, Inc., Dept. E-41, Butler, Pennsylvania.*

**MAGNETICS inc.**

When to specify  
**VULCAN ELECTRIC  
CARTRIDGE  
HEATERS**

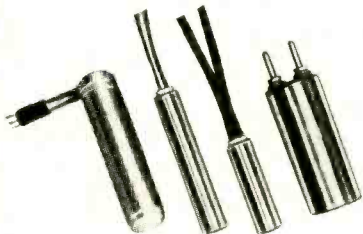

**1. When application is for:**

Complete insertion into machine parts, dies, platens, molds, presses, die blocks of embossing machines, packaging machines, etc.

**2. When specifications call for:**

Length—1" to 25" (or longer); diameter— $\frac{1}{4}$ " to  $1\frac{1}{64}$ " (or greater); wattage—10 to 3200 (or higher); voltage—standard 115 or 230, special 6 to 440; sheath—brass, steel, nickel or high temperature alloys; standard or special lead wires or terminals.

**3. When you have "hot" problems:**

Vulcan Engineers are ready to provide special heating units—engineered to your needs.

**Complete Line of  
ELECTRIC  
HEATING UNITS**

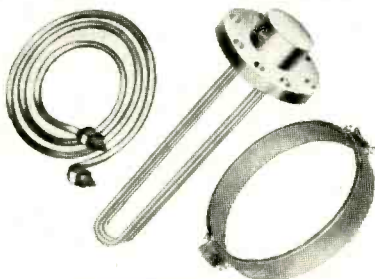

Whatever your need for electric heat, Vulcan offers you a complete line of low-cost, efficient units—cartridge, strip, tubular, finned, immersion, band and ring heaters. Write for catalog.

**VULCAN**

**ELECTRIC COMPANY**  
DANVERS 10, MASS.

Cartridge • Strip • Tubular • Immersion Electric Heaters • Soldering and Branding Irons • Solder and Glue Pots

Circle 104 Readers Service Card

no antenna and transmission line losses. If these losses are to be considered, they may be added directly to the receiver noise factor. The  $y$  intercepts are the contribution of galactic noise.

These curves are of significance in tv tuner design, since they show the overall system improvement brought about by any reduction in receiver noise. For example, reducing the receiver noise factor from 4 db to 1 db at channel 4 produces only about 0.5 db improvement in the entire system noise factor. A one-to-one improvement ratio is found only at the higher vhf channels.

The above information is drawn from the paper, "Galactic Noise—An Important Design Consideration of VHF Television Tuners" by

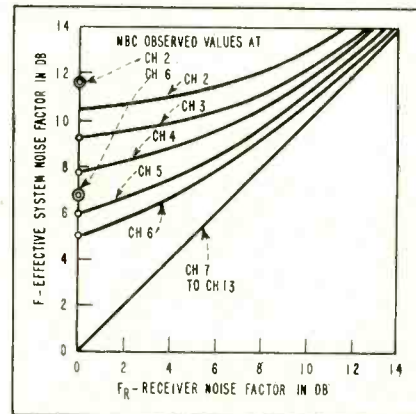

FIG. 2—Effect of galactic noise on effective system noise factor. Discrepancies between these measurements and the Bureau of Standards data are within the normal variations of galactic noise

D. Carson of the RCA Victor Television Division—N.H.

## Preamplifier for Ceramic Pickups

By WILLIAM NEWITT

Senior Engineer  
Electro-Voice, Inc.  
Buchanan, Mich.

It is desirable that ceramic phono pickups have low source impedance, with an output voltage comparable to that of a magnetic pickup. Some power gain should also be provided so that the ceramic unit may compare favorably with the high power sensitivity of a magnetic pickup.

Power gain may be provided by a transistor amplifier. By placing the amplifier close to the pickup, minimum hum and noise pickup as well as minimum loss due to shunt capacitance can be obtained.

The highest input impedance obtainable from a transistor may be realized from the common-collector configuration. Since the input impedance depends also to a considerable extent on the output load of such a circuit, satisfactory results have been obtained by a tandem type of circuit. Two transistors are used in a cascade-common-collector configuration with the input impedance of one stage comprising the load of the preceding stage.

An experimental circuit, shown in Fig. 1, utilizing 2N184 transistors can handle two volts rms input without introducing distortion. With simulated ceramic pickup,

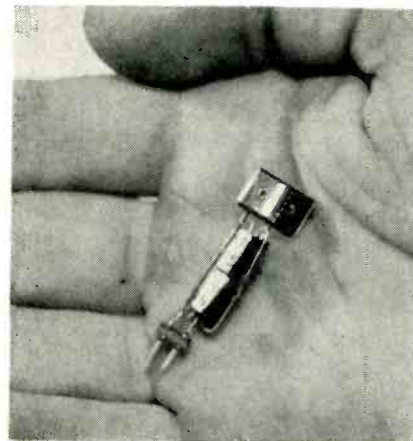

Complete preamplifier can be housed in tubing  $\frac{5}{16}$  in. wide and  $\frac{3}{4}$  in. long

having 500  $\mu\text{f}$  internal capacitance, coupled to the input, open-circuit output response is within  $\pm$  db from 35 to 40,000 cycles. Output impedance is 120 ohms at 1,000 cycles.

The transistor assembly was built into a small phenolic tube  $\frac{3}{8}$ -inch in diameter and  $\frac{3}{4}$ -inch long. Plugs fitted at each end permit attachment directly to the pickup. Actual performance verified the results obtained with the simulated ceramic pickup. Total loss in gain resulting from insertion of the transistor unit was  $\frac{1}{2}$  db.

At 1,000 cycles, the impedance of the 500  $\mu\text{f}$  pickup would be about



# 50 ohm Coax Terminations dc to 4 KMC!



## 8 new instruments! 1 to 500 watts coverage!

New Sierra 160 series Coaxial Terminations are ideal for use with directional couplers, or in other applications requiring wide frequency range and low VSWR. They provide extremely high stability, and will dissipate full rated power continuously up to an ambient temperature of 40°C. Derating permits operating at still greater ambient temperatures. Terminations are completely shielded, and may be used to adjust transmitters without radiation. They are also useful for converting Sierra Bi-Directional Power Monitors to a termination type wattmeter.

### SPECIFICATIONS

Model	Power*	Connectors	VSWR
160-1F	1 watt	Type N fem.	Less than 1.06, dc to 2 KMC; less than 1.08, dc to 4 KMC.
160-1M	1 watt	Type N male	
160-5F	5 watts	Type N fem.	Less than 1.08, dc to 4 KMC.
160-5M	5 watts	Type N male	
160-20F	20 watts	Type N fem.	Less than 1.08, dc to 1 KMC; less than 1.15, dc to 4 KMC.
160-20M	20 watts	Type N male	
160-100F	100 watts	Type N fem.	Less than 1.2, dc to 3300 MC.
160-500F	500 watts	Type N fem.	

\*Up to 40° C ambient.

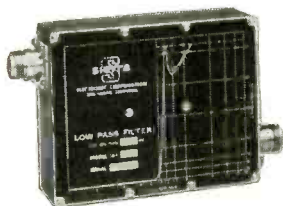

### New LOW PASS FILTERS

Sierra 184 series Low Pass Filters have an insertion loss not more than 0.4 db in pass band, sharp cut-off, 1.5 VSWR or less, and rejection greater than 60 db from 1.25 to 10 times cut-off frequency. Five models: for cut-off frequencies of 44, 76, 135, 230, 400 MC. Power range 250 watts in pass band, 25 watts in rejection band.

Write for Bulletin!

## Sierra Electronic Corporation

A Subsidiary of Philco Corporation  
3885 Bohannon Dr., Davenport 6-2060, Menlo Park, Cal., U.S.A.  
Sales Representatives in major cities  
CANADA: Atlas Radio Corp., Ltd., Toronto, Montreal, Vancouver, Winnipeg  
EXPORT: Frazer & Hansen, Ltd., San Francisco, New York, Los Angeles



# Sierra

## WIDEBAND DIRECTIONAL COUPLERS

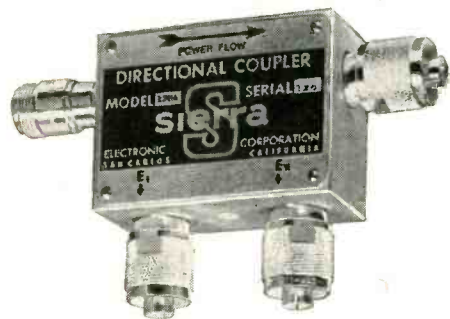

Versatile, accurate Sierra couplers are offered in 6 models for frequencies 10 kc to 2000 mc. Couplers provide transmission line measurements including reflection coefficient, VSWR, power. Also permit matching of loads to lines dynamically by indicating conditions providing minimization of reflected voltages. Request Bulletins 101, 104.

Coupling Factor: (in db ± 1 db)

Model	10 kc	3 mc	10 mc	30 mc	100 mc	300 mc	1000 mc	2000 mc
137, 137A				73	63	53	43	37
138, 138A				59	49	39	29	
145		52	42	32	22	12		
150				53	43	33	23	
139	50	50						

Directivity: 12 db ± 3 db greater than coupling factor at each frequency.

Impedance: Models 137 and 138 are 51.5 ohms. Models 137A, 138A, 145 and 150 are 50.0 ohms. Model 139 may be matched to most impedances.

Power: Usable to 1000 watts throughout frequency range.



### SIERRA 148 CRYSTAL DETECTOR

Insures sensitive readout for Sierra Directional Couplers. Low VSWR, high sensitivity to 1200 MC. 50 ohm input impedance, filtered output. Type N input, BNC output connectors.

Data subject to change without notice

3663-1

# NOW...ANY MICROWAVE COMPONENT CAN BE BUILT AND ENGINEERED TO YOUR PARTICULAR APPLICATION

Regardless of complexity, design or tolerance problems—you can get UHF or microwave components that are job-engineered to your application. All units are delivered, *electrically tested and proven*, ready for immediate operation.

Components can be built from your prints or can be designed and built to integrate with the application. Close and confidential coordination is maintained from drawing board stage to installation.

Range of assemblies is practically unlimited—from dc. to over 40,000 mc., military or industrial. Typical examples are these components, delivered ready for field use:

## Telemetering . . .

### Tunable S-Band Transmitter Cavity—

re-entrant type, pulse output 150 w., operates at extreme altitudes and under extreme conditions of temperature, humidity and salt spray.

## Improving signal-to-noise ratio . . . selectivity . . .

### Tunable UHF Pre-Selector—

relatively low frequency coaxial resonator with very low insertion loss, extreme selectivity and very high signal-to-noise ratio. Especially adapted to use in aircraft or in crowded communication bands.

## Calibrating . . . designing S-Band components . . .

### S-Band Signal Generator Cavity—

re-entrant type, complete with thermistor mount and calibrated variable attenuator. Frequency range 2700 to 3400 mc.

Get the facts on our complete design, engineering and mechanical fabrication facilities. Have us quote on your needs—cavities, mixers, duplexers, multipliers, rotary joints, twists, bends and other components or assemblies.

Contact us today. Request catalog.

**CUSTOM-ENGINEERED MICROWAVE PARTS**

**J-V-M ENGINEERING COMPANY**

4631 LAWNDALE AVENUE, LYONS, ILLINOIS (Chicago Suburb)

Circle 106 Readers Service Card

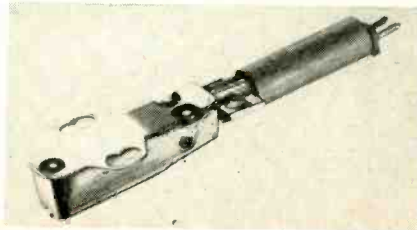

Transistor preamplifier unit installed on phono cartridge can be mounted in phono-graph pickup arm

32,000 ohms. Increase in power sensitivity of the pickup with the attached transistor unit is about 300 times. Thus, a power gain of about 25 db has been provided, and the ceramic phono pickup is cap-

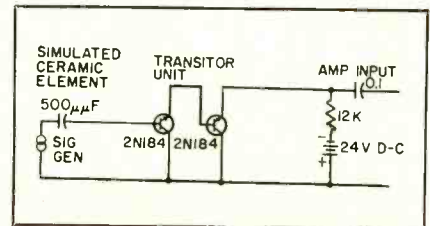

FIG. 1—Simple transistor amplifier can be built into phono pickup arm with power supply installed in amplifier

able of driving low load impedances.

The only change required in the existing equipment is the addition of a low-current d-c supply and two components to the preamplifier unit.

## Simple Transistor Sweep Generator

By H. L. ARMSTRONG

National Research Council  
Ontario, Canada

TRANSISTOR multivibrators can be operated either as triggered or free-running sweep generators.

The circuit of a triggered sweep generator is shown in Fig. 1. Initially,  $Q_2$  is conducting rather heavily while  $R_2$  provides enough bias current to almost bottom the collector of  $Q_2$ . Transistor  $Q_1$  is near cut off. A positive trigger cuts  $Q_2$  off and its collector voltage instantly rises in absolute value. This rise, which causes the initial step in the waveform of Fig. 2 is coupled to  $Q_1$ , turning it on. Then the signal at the collector of  $Q_1$  is fed back to  $Q_2$ , cutting it off.

The current drawn by  $Q_1$  through  $R_1$  makes the voltage available at point A for  $Q_2$  less, in absolute value, than it would otherwise be. This voltage begins to charge capacitor C, and the charging current keeps  $Q_1$  turned on. As C becomes charged, the rate of charge, (slope of the sweep), tends to decrease. This causes  $Q_1$  to draw less current. Thus the voltage at point A increases in absolute value, tending to maintain the sweep rate. This feedback improves the linearity of the sweep.

At the end of the sweep,  $Q_2$  begins to conduct. The change which this produces at the collector is coupled to  $Q_1$ , cutting it off.

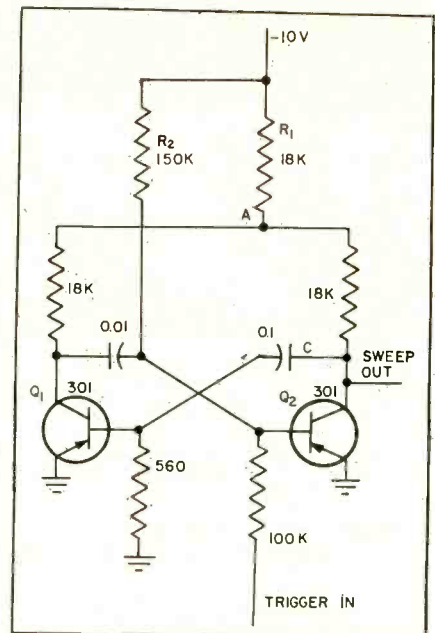

FIG. 1—Triggered sweep generator can be made free-running by increasing value of resistance  $R_2$

This feeds back a signal to  $Q_2$ , causing it to conduct very heavily discharging C. Thus the flyback is achieved at the end of the sweep.

If *npn* transistors were used all polarities would be reversed, thus obtaining a positive sweep. The circuit can be made to free-run by altering  $R_2$  to larger values. Waveforms obtained are similar to those for triggered operation.

Figure 2 shows a typical waveform for triggered operation. The trigger, shown on the lower trace, represents about 80 microamperes



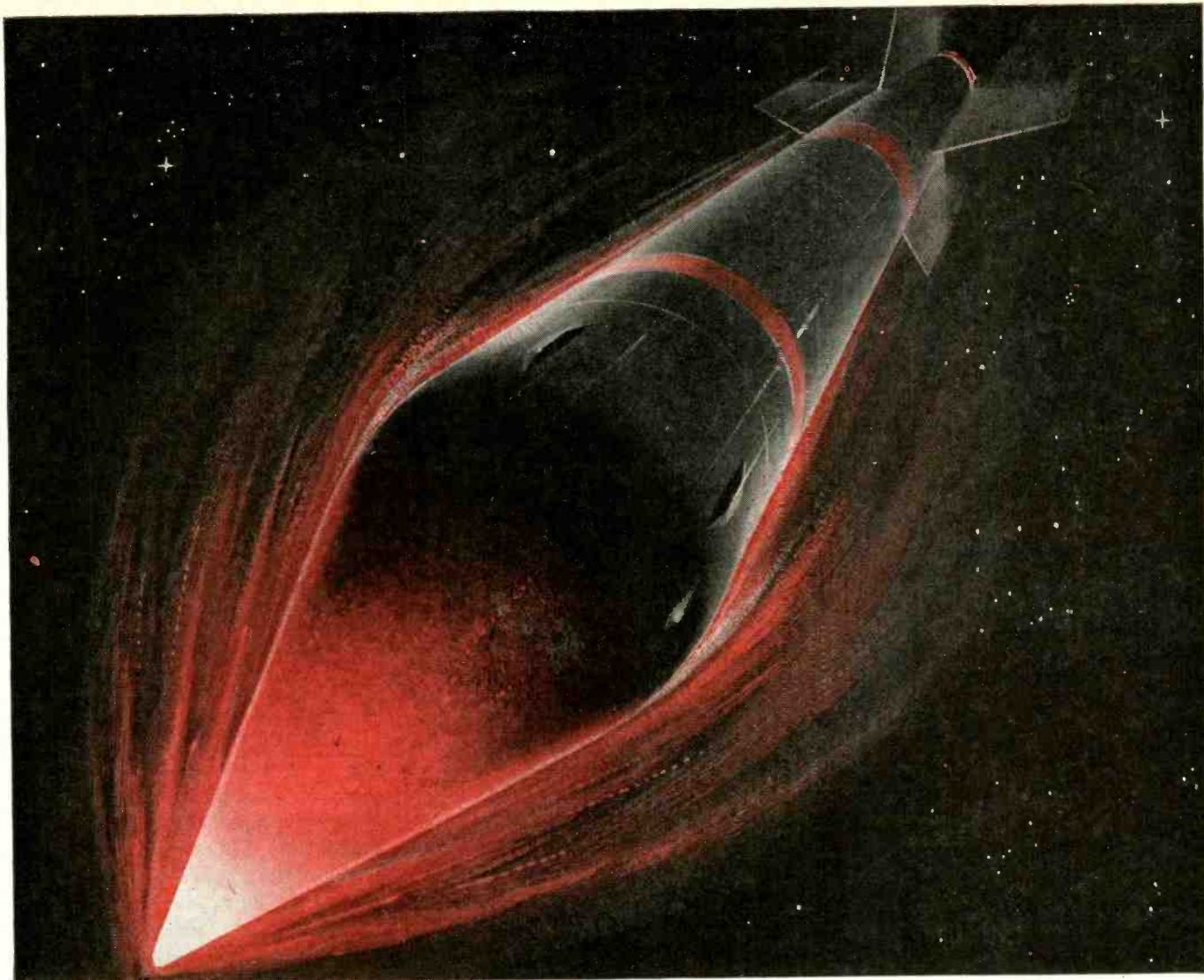

Sustained operating temperatures up to 400° F, as in guided missiles, are death to inferior electrical insulations and laminates. CDF glass-base laminates of Teflon\*—the only laminates of their kind approved by the military—can take this punishment steadily.

## LATEST HIGH-HEAT INSULATION SYSTEMS NEED CDF GLASS-BASE LAMINATES AND TAPES

**Widest available range offers Teflon, epoxy, silicone, mica products for dimensional stability under continuous heat**

As components and equipment grow smaller, and heat becomes more difficult to dissipate, CDF high-heat electrical insulations become increasingly important to electronic design. For nowhere else can such a wide range of quality insulations be found under one roof as at CDF.

**FOR HIGH-HEAT PRINTED CIRCUITRY,** CDF glass-base metal-clad laminates of Teflon\* and epoxy exhibit best dimensional stability and current-carrying capacity. Constant operating temperatures of 300°F — soldering temperatures to 500°F — are readily met by these specialized CDF Dilecto® laminates.

**HIGH-HEAT FLEXIBLE INSULATIONS.** CDF offers a wide choice of insulating tapes made of Teflon, silicone varnish, silicone rubber, and Micabond®, with glass-cloth support. CDF tapes may be used either by hand

wrapping or on automatic winding machines. Unsupported Teflon in colors available to meet MIL-STD 104.

**TEFLON SPAGHETTI TUBING AND OTHER SPECIALTIES.** Part of CDF's vast fabrication facilities is devoted to the production of custom parts from Teflon — spaghetti tubing, rods, sheets, and machined parts to rigid specifications.

**NEW — cementable** Teflon, bondable to itself and to other materials with commercial adhesives.

**SEE SWEET'S** Product Design File, Electronics Buyers' Guide, and other directories for the name and phone number of your CDF sales engineer. Then send your print or your problem, and we'll return specific technical data and test samples.

\*trademark of DuPont tetrafluoroethylene resin

**CDF** **CONTINENTAL-DIAMOND FIBRE**  
A SUBSIDIARY OF THE **Buditt** COMPANY • NEWARK 16, DEL.

deep in the heart of  
the U. S. AIR FORCE

"HUSTLER"



SEAELECTRO  
**PRESS-FIT**®

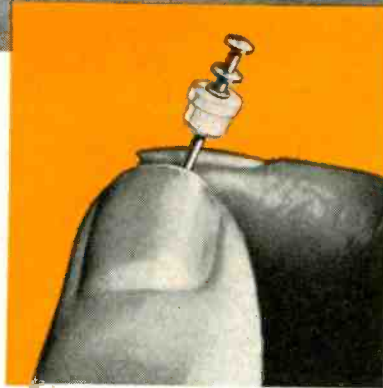

## TEFLON† TERMINALS

America's first supersonic bomber, the B-58 "Hustler", flies above 50,000 feet, with a crew of only three!

Hence a maze of electronic equipment for the many automatic functions. On such equipment rests the success of our defense program and the maintenance of peace.

The electronic gear, in turn, depends on its insulation barrier, even down to the tiniest Teflon-insulated terminal. There must be no failure—electrical, mechanical, thermal or from any other cause.

That Seaelectro's original and genuine "PRESS-FIT" terminals are used in the "Hustler" program, speaks for itself. Available in hundreds of standard and stocked miniature and subminiature types . . . widest selection of lugs and platings . . . eight different code colors . . . backed by the pioneer's installation "know-how".

**NEW MANUAL!** Write on business stationery for the big "PRESS-FIT" data book. Also samples.

**OR VISIT US AT WESCON SHOW!** Booth 2619 for exhibits; Sheraton Plaza for consultations and entertainment.

†Reg. Trademark,  
E. I. Du Pont de Nemours & Co.

**Seaelectro**  
CORPORATION

610 Fayette Avenue, Mamaroneck, N. Y.



peak signal. Duration is not critical. The output sweep waveform is shown in the upper trace. Its linear part represents about 0.5 volt, and duration is about two milliseconds.

The output of the multivibrator

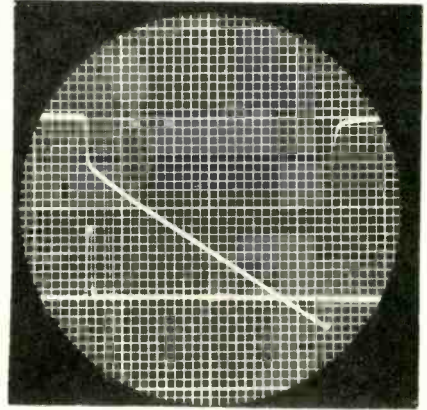

FIG. 2—Trigger pulse and sweep waveform for simple transistor sweep generator

can be loaded heavily enough to drive an ordinary grounded-emitter transistor amplifier stage. In one application it was possible to connect the output directly to the base of the amplifier stage through a 10,000-ohm resistor without harming the waveform.

## Low-Mu Triodes Control Power

By JOHN DEGELMAN  
Dept. of Biology  
Boston University  
Boston, Mass.

VALVE solenoids and similar electro-mechanical devices can be controlled by 6AS7 or 6336 low- $\mu$  triodes when difficulties, due principally to the low  $\mu$  of these triodes, are overcome.

The 6AS7 will pass 125 milliamperes per section and the 6336 nearly 400 per section, whereas a comparable beam-power tetrode handling no more than half the current of the 6AS7, demands a plate potential of nearly double the 150 volts required by the 6AS7 and is more critical as to plate load matching. Further, the plate load resistance of the 6AS7 may be as little as 300 ohms, that of the 6336 but 200 ohms.

With a plate supply of 150 v, the



# When you need Reliable Control of Timing

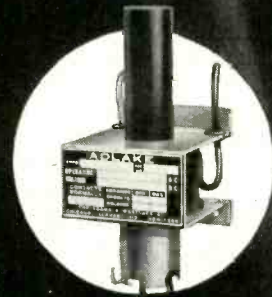

you need **Adlake**  
*mercury-to-mercury*  
relays

You are invited to Booth 1505  
12th Annual Instrument-Automation Exhibit  
September 9th - 13th  
Cleveland Auditorium, Cleveland, Ohio

- Mercury-to-Mercury contact of Adlake Relays gives ideal snap-action with no pitting, sticking or burning.
- Hermetically sealed at the factory so dust, dirt, moisture cannot affect them.
- Time delay characteristics are fixed and tamper-proof.
- Adlake Relays are quiet, chatterless and require no maintenance whatever.

If you have a control problem, our engineers will be happy to help you solve it. There's no obligation. Write The Adams & Westlake Company, 1171 N. Michigan, Elkhart, Indiana.

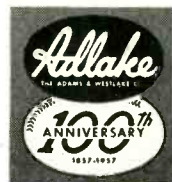

The Adams & Westlake Company  
NEW YORK ELKHART, INDIANA CHICAGO  
original and largest manufacturers of plunger-type relays

# PHILCO®

REGISTERED TRADEMARK OF PHILCO CORPORATION

uses **ERIE "PAC"**  
in its newest  
**TV models**

to...

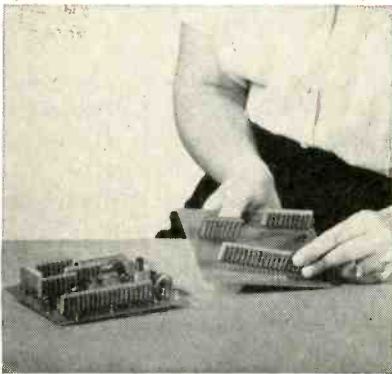
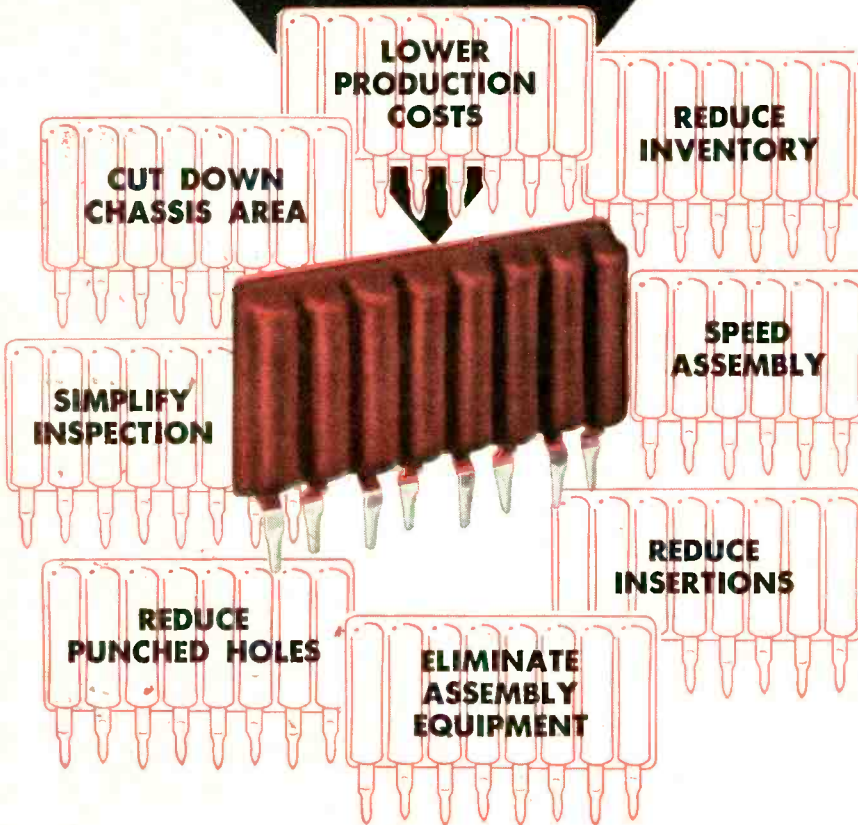

The ERIE Pre-Assembled Components system, known as PAC, is a custom designed module containing standard resistors and capacitors mounted to a printed wiring board. Other manufacturers of many types of electronic equipment are taking advantage of similar benefits of lower production costs and more compact chassis assemblies by the employment of PAC's. Our engineers will be glad to consult with you about incorporating PAC in your equipment.

**ERIE** *Electronics Division*  
**ERIE RESISTOR CORPORATION**  
 MAIN OFFICES: ERIE, PA.  
 FACTORIES: ERIE, PA. • HOLLY SPRINGS, MISS. • TRENTON, ONTARIO, CANADA

grid of one triode section must be made  $-75$  v with respect to its cathode to cut off plate current. Also, it is not possible to cut off one triode section by a cathode resistor common to both triode sections with but one section passing full plate current.

In overcoming control difficulties to make use of the unique characteristics of the 6AS7, the circuit shown was devised for the operation of a laboratory respirator.<sup>1</sup> In the plate load circuits of the 6AS7 are solenoids used to pull a slide-fitting air-valve piston to and fro in a cylinder.

In the circuit shown, owing to the operation of a free-running

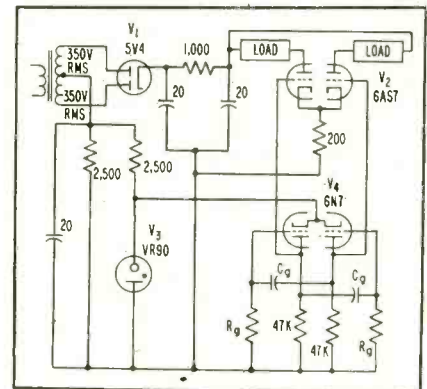

Circuit of the solenoid-actuating device, using direct-coupled tubes

multivibrator, the solenoids act alternately, one being supplied with 100 ma while the opposite solenoid is cut off and passes less than 0.25 ma.

The 6AS7 is controlled by a low-frequency astable multivibrator  $V_4$ , which is operated with  $-90$  v supplied to the cathode in a manner previously described.<sup>2</sup> For other applications,  $V_4$  may be arranged as a bistable or monostable multivibrator.<sup>3</sup> With the high voltage applied to  $V_4$  as a negative potential at the cathode, the anode potentials of  $V_4$  become negative with respect to ground. This makes possible a direct coupling from the plates of the controlling tube to the grids of the controlled tube.

The grids of the multivibrator, although connected to ground via the two grid resistors  $R_g$ , are also returned to the point of highest positive potential. Early examples



# PRECISION TRANSISTOR ANALYZERS

## 5-Function Versatility BCT-300



1. Full Family Curve Tracing plus scope calibration.
2. Input impedance and current gain versus frequency can be read directly on a meter.
3. Energizing, detecting and measuring circuit performance.
4. Forward and reverse diode checking.
5. Testing of neon lamps, magnetic elements, other networks.

### PERFORMANCE ADVANTAGES

- a. Tests all PNP and NPN transistors in either grounded base or grounded emitter configuration.
- b. Provides frequency response for small signal testing to 1.0 megacycle.
- c. Sweep circuit provides 270 volts, 10 amperes, or 20 watts.
- d. Input current available to  $\pm 110$  milliamperes.
- e. Operates at a precision level accuracy of  $\pm 2\%$ .

### BLOCK DIAGRAM OF BCT-300 SHOWING VARIETY AND FLEXIBILITY OF TEST FUNCTIONS.

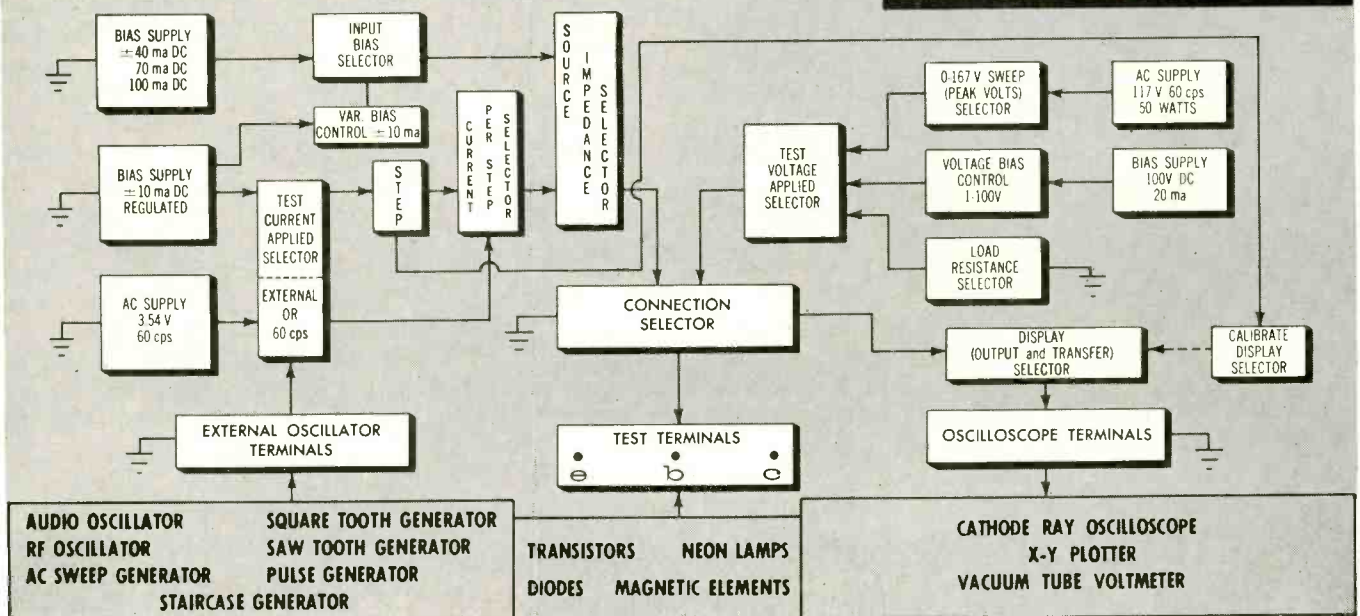

## Wide Range Parameter Testing BTS-400

1. Provides direct meter reading of all hybrid parameters in grounded base or grounded emitter configuration.
2. DC bias settings are continuously adjustable, and metered with maximum ratings of 6 amperes, 150 volts, or 60 watts.
3. Current transfer ratio parameter range of 1/10 to 1,000 covers all commercially available transistors.
4. This is the only test unit made with an input impedance parameter range of 10 to 100,000 ohms.
5. Precision parameter measurement to within  $\pm 2\%$  provides the highest accuracy of any commercial unit.

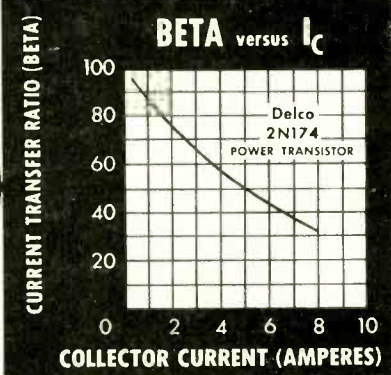
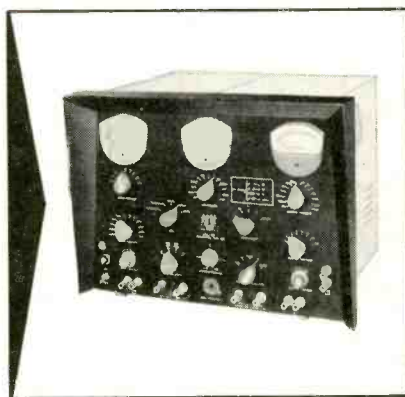

The curve shown above on the 55 watt Delco 2N174 was obtained with Norden-Ketay BTS-400 Test Set.



Write for Bulletins containing full data on these transistor measuring devices to:  
Norden-Ketay Corporation, Instrument & Systems Division, Wiley St., Milford, Conn.

Sales Offices: Stamford, Conn. | Chicago  
Washington, D.C. | Dayton, Ohio | Los Angeles

telephone quality  
in a miniature relay?

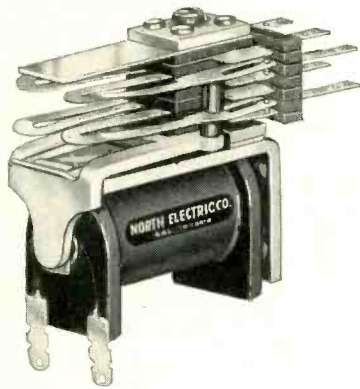

yes!  
**IN NORTH  
"M" TYPE  
RELAY!**

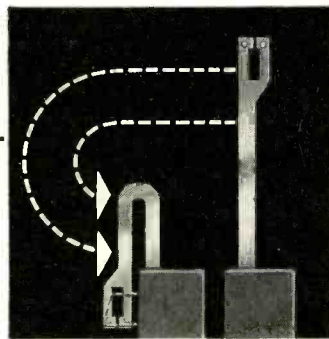

Note the "U" shape of the lever springs. From the pile-up, the lever spring extends the full length of the coil, then doubles back an equal distance to the fixed contact points.

Stability of operating characteristics, with which relay dependability is achieved, can be maximized by a configuration which puts the fixed contact springs as close as possible to the clamping axis of the pile-up and yet escapes the penalty of the greatly foreshortened lever spring common in miniaturized relays.

In the North "M" Relay, both requirements have been met.

The fixed contact springs are lateral extensions from the anchoring pile-up, minimizing any possibility of post-adjustment variation.

The unique "U" design of the lever springs in North's "M" Relay enables it to meet critical space requirements while retaining lever spring length to achieve telephone dependability.

The armature in North's "M" type relay operates on a knife hinge—never needs lubrication, and the small amount of armature travel provides fast operation.

Lightweight operating parts keep contact bounce at an absolute minimum.

North's "M" type relay can be furnished with 6, 12, 24, 48, or 100 Volt coils; 1, 2, or 4 DPDT standard spring arrangements; with double gold or single silver contacts; with dust cover and octal mounting plug.

North's "M" type relay is available from stock.

Length 1-13/16", Height 1-1/4", Width 25/32", Weight 1.8 oz.

INDUSTRIAL DIVISION

**NORTH ELECTRIC COMPANY**

778 SOUTH MARKET STREET • GALION, OHIO

Available in Canada through Ericsson Telephone Sales of Canada, Ltd., Montreal 8, P. Q.



Table I—Characteristics of Twin Power Triodes

Type	$\mu$	$r_p$ in ohms	$g_m$	$i_p$ in ma	plate diss in w
6AS7	2	280	7,000	125	13
5998	5	300	11,000	135	15
6080	ruggedized version of 6AS7				
6336	2	250	11,000	400	30
6394	same as 6336 with 26.5-v heater				

fied by the manufacturers as allowable for the 6AS7.

The low plate supply voltage required for the 6AS7 allows the rectified and filtered power supply to be divided into a positive potential supply and a regulated negative potential supply for operation of the multivibrator, without an overly high initial supply voltage. The total available voltage from the filtered power supply does not exceed 300.

Power rectifier  $V_1$  is a type 5V4 with an indirectly heated cathode. Full power-supply voltage is not delivered by the 5V4 until after a time lapse of more than 15 seconds following heater and high voltage a-c application to the 5V4. This time delay is considered enough to protect the cathodes of the 6AS7 plates before the tube's cathodes have come up to operating temperature.

The alternative to this design is to provide a time-delay relay. The cathodes of these low- $\mu$  power triodes are subject to severe damage or ruin if full power-supply voltage is applied to their plates before the cathodes have come up to operating temperature.

A tabulation of the characteristics of twin power triodes useful in the described applications are shown in Table I.

#### REFERENCES

- (1) J. K. Merlis, & J. Degelman, An Improved Animal Respirator For Laboratory Use, *Science*, 144, No. 2,974, 1951.
- (2) J. Degelman, Phototube Operated Trigger Circuit, *ELECTRONICS*, p. 134, Jan. 1948.
- (2) J. Degelman, Phototube operated Nichol. D. Sayre and F. C. Williams, "Waveforms," Rad. Lab. Series, 19, McGraw-Hill Co., New York, N. Y., 1949.

### Electro-optical Amplifier

IN CONJUNCTION with a photoconductor, an electroluminescent cell can be used as an electrical power amplifier and also as a bistable trigger device. Such a device has



SHIELDING'S *Universal* ENCLOSURE  
PROVIDES MAXIMUM SHIELDING EFFECTIVENESS  
. . . FOR COMPLYING WITH ALL APPLICABLE  
MILITARY SPECIFICATIONS.

# R. F. *interference* SUPPRESSED

Shielding has the practical solution to all your electro-magnetic suppression problems — the Shielding Universal Enclosure. Multi-Cell® design features either single or double shielding in cell or isolated type enclosure . . . interchangeable standard panels of solid and/or mesh material . . . a wide variety of enclosure sizes both standard and custom-built. A complete test report, performed by independent consulting engineers in accordance with military specifications, has just been completed — evaluating designs and different types of material used. For your copy of this report and the new Shielding folder giving all design details, write today to:

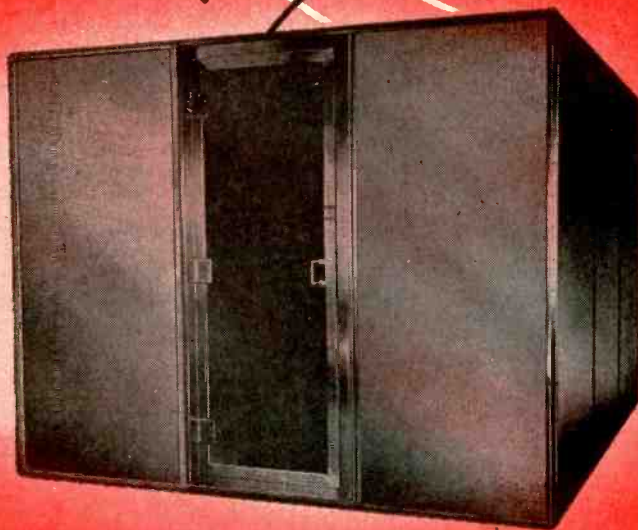

## SHIELDING, INC.

18 READE ST., RIVERTON, N. J.

**SALES OFFICES:**

CHICAGO — R. EDWARD STEMM  
DENVER — WILLIAMS & ASSOCIATES  
LOS ANGELES — CARL A. STONE ASSOCIATES, INC.  
FORT WORTH — MITCHELL SPEARS COMPANY  
SEATTLE — G. M. GILLETT COMPANY  
CANADA — MJS ELECTRONICS SALES LTD., AJAX, ONTARIO  
EXPORT AGENT — ELECTRO-NUCLEAR COMPANY, SEATTLE

## for ACCURATE MEASUREMENT of FREQUENCY, PERIOD, or TIME INTERVAL

*Electro-Pulse*  
presents the new  
**MODEL 7550B**

- 5¼" x 17" Panel Size
- Crystal Accuracy
- Measures 0.1 CPS—100 KC
- Measures 10  $\mu$ s—1.2 days

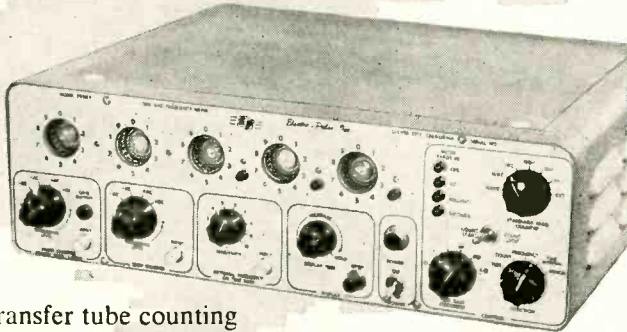

Featuring glow transfer tube counting techniques and printed wiring throughout, Model 7550B offers optimum reliability, economy, and accuracy for general purpose use in frequency and time measurement.

Write for complete data: our Bulletin 7550B/E  
Representatives in Major Cities

**FOR SCIENCE AND INDUSTRY**

## *Electro-Pulse* PULSE INSTRUMENTATION

- PULSE GENERATORS
- TIME DELAY GENERATORS
- PULSE CODE GENERATORS
- MAGNETIC CORE TESTING EQUIPMENT
- BLOCK UNITS FOR TEST SYSTEMS

VERSATILE ...

... WIDE RANGE ... ACCURATE ... SERVICEABLE

Utilizing advanced circuitry, Electro-Pulse offers a broad line of proven equipment for applications in development and test of RADAR, navigational aids, digital computers, data handling equipment, fire control systems, guided missile control, ballistics research, etc.

### MEGACYCLE PULSE GENERATOR MODEL 3450A

- 20 CPS to 1.6 Megacycles
- 0.1 to 5  $\mu$ s pulse width
- 0.1 to 5  $\mu$ s pulse delay
- 50 volt low impedance output

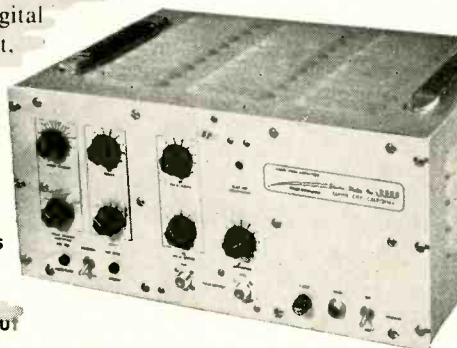

Representatives in Major Cities

**EP** *Electro-Pulse, Inc.*

11861 TEALE STREET, CULVER CITY, CALIFORNIA  
Telephones: EXmont 8-6764 and TEXas 0-8006

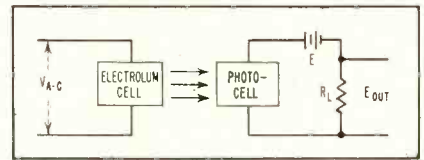

Electro-optical power amplifier

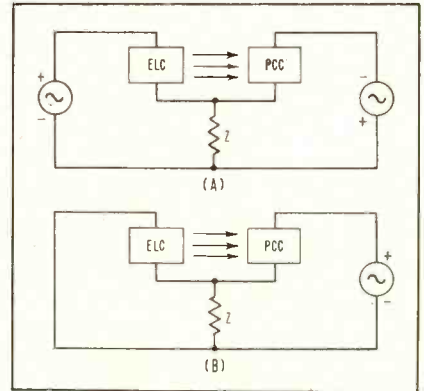

Common impedance develops regeneration (A) or bistability (B)

been used experimentally and found to have a power gain of 50 db. Frequency response of existing devices is poor.

Primary advantages of this type of trigger circuit are the inherently low cost of components and flexibility of the circuit. Triggering is accomplished by mechanical, electrical or optical means. Output can be either optical or electrical.

In the experimental circuit, the electroluminescent cell used a zinc responsive copper-activated zinc sulfide. The photocell employed cadmium sulfide, thus putting the spectral response at peaks in the green region.

Power gain was increased by the use of regeneration, achieved through use of a suitably phased a-c source and a common impedance illustrated. Proper choice of the common impedance and the voltage sources produces a bistable circuit.

This information has been furnished by General Electric Co., Syracuse, N. Y.

## Transistor Beta Tester

BY JOHN D. HARMER  
Raytheon Manufacturing Co.  
Waltham, Mass.

COMPACT instrumentation used in conjunction with an oscilloscope with d-c amplifiers makes it possible to trace out the beta-curve (relationship between base current



# Pacemakers in the technology of our electronic age

Certain discoveries, inventions and developments of Bell Telephone Laboratories have been truly epochal in their effect upon the technology of our time. Each has come out of a single quest—a search for ways to make telephony ever better. But many have opened the way to exciting advances in TV, movies, radio, horology, astronomy. Here are ten of Bell Laboratories' contributions to the modern world.



**Electronic amplifier.** First high-vacuum electronic amplifier. Made possible long distance telephony and then opened the way to radio broadcasting.

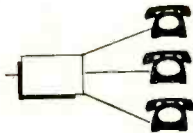

**Wave filter.** Precisely separates bands of frequencies. Provided major key to economical sharing of the same wires by many voices or radio programs. Indispensable control tool in radio, television and radar.

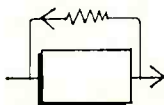

**Negative feedback amplifier.** Provides distortionless and stable amplification. Made possible the enormous, precisely controlled amplification needed in long distance telephone calls. The principle is now basic in high-quality amplifiers for radio, TV and high-fidelity reproduction.



**Quartz crystal.** Standard super-accurate quartz crystal oscillator developed for frequency controls in radio telephony. Has also become the standard control for clocks in world's astronomical laboratories.



**Coaxial cable system.** Hollow tube with a central conductor was developed to transmit hundreds of voices simultaneously. Now also provides long distance carrier for TV in partnership with microwave beams.



**Transistor.** Tiny solid-state device uses extremely small amounts of power to amplify signals. Makes possible electronic telephone switching and much smaller hearing aids, radios, TV sets and electronic computers.



**Dial system "brain and memory."** Takes over your call and sees that you are connected in the best and quickest way. Newest example: Direct Distance Dialing from home telephones to any part of the nation.

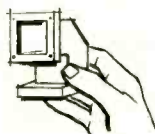

**Waveguide.** Hollow conductor transmits high-frequency waves. From this came the "pipe" circuits that are essential to radar and very short-wave radio communications.

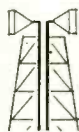

**Microwaves.** Bell Laboratories developed long distance microwave transmission. It operates by focusing radio beams from station to station, carries cross-country telephony and TV.



**Radio astronomy.** This great new science began in the study of radio interference at Bell Laboratories . . . with the tremendous discovery that radio waves emanate from the stars.

**BELL TELEPHONE LABORATORIES**  
WORLD CENTER OF COMMUNICATIONS RESEARCH AND DEVELOPMENT



# NEW! Syncramental motor provides precise bi-directional stepping

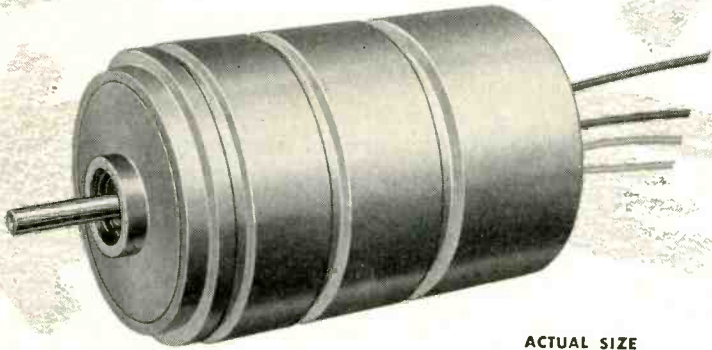

ACTUAL SIZE

The Syncramental Motor accurately translates pulses to incremental shaft position for conversion of digital information to analogous shaft displacements. Compact, long-life power can rotate potentiometers, counters, rotary switches, control mechanisms.

A special magnetic clutch mechanism, rather than ratchets, indexes the shaft. Clutch and detent mechanism are mounted between two Ledex Rotary Solenoids whose armature plates face each other. Clutch rotates with one or the other of the energized armatures, to which it has been magnetically attracted, causing shaft rotation. Solenoid de-energizing returns the armature to original position, but clutch and shaft are held in displaced position by the detent.

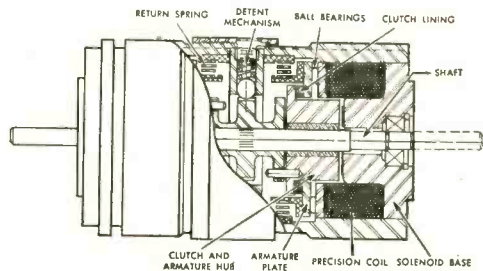
**PERFORMANCE:**

Angular increment per pulse— $36^\circ$  (either direction). Detent accuracy— $\pm 1/2^\circ$  under no load conditions. Maximum stepping rate—15 per second. Load capacity—up to 2 lb. in. starting torque at  $20^\circ\text{C}$ . Life expectancy—2 million steps in either direction.

**ENVIRONMENTAL CONDITIONS:**

Temperature—minus  $55^\circ\text{C}$ . to  $120^\circ\text{C}$ . Altitude—up to 90,000 ft. Meets applicable requirements of MIL-E-5272A.

**SIZE, MOUNTINGS:**

Dimensions—1.500" dia. x 2.525" long. Weight—13 oz. Mountings—standard Servo.

*Write today for complete data...*



**SYNCRAMENTAL  
MOTOR**

**G.H. Leland  
INC.**

123 WEBSTER STREET, DAYTON, OHIO

IN CANADA: Marsland Engineering Ltd., Kitchener, Ontario  
IN EUROPE: NSF Ltd., 31-32 Alfred Place, London, England

$i_b$ , and collector current  $i_c$ ) of any junction transistor. The instrument operates from a 60-cycle supply and the curve is swept at this frequency. A single switch reverses all polarities so either *nnp* or *pnnp* transistors can be measured. The collector bias is adjustable in 12 steps between 2 and 60 volts. A calibration device is included that enables the scale of collector and base currents in the display to be determined.

The transistor to be tested is inserted in the subminiature socket. Terminals  $G$ ,  $I_b$ , and  $I_c$  are connected to the oscilloscope common and X and Y plate terminals respectively. The collector bias voltage is produced across a 10-kilohm

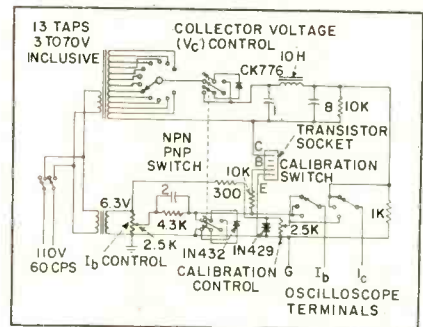

Circuit diagram of the transistor beta curve tracer showing connections to be made to a cro

resistor by a half-wave rectifying circuit and a smoothing filter.

This voltage is adjusted by switching to various taps on the transformer secondary. Collector current circulates through a 1,000-ohm resistor to ground and from there through the emitter to the collector and back to the power supply. The voltage across the 1,000-ohm resistor indicates instantaneous collector current.

The transistor base is fed via a 10-kilohm resistor from a 2.5-volt transformer secondary across a 6.3-volt transformer secondary. Ideally, the base current should sweep from zero to a maximum and then back to zero only, without reversal of polarity, as transistor action occurs only in one current direction.

An automatic d-c biasing circuit is therefore included in the base supply, which comprises a 4.3-





**write for sample installed on YOUR wire!**

Inspect a SEALINK sample installed on *your* wire...only then will you grasp the significance of this newest of Burndy developments for wiring! Here is the very first fully water-sealed splice exceeding all immersion, dielectric, voltage drop and tensile strength requirements...a splice that keeps out the elements. Rapid, controlled SEALINK installations are made with the Burndy MR8 Hand Hytool without need for reversing the tool. SEALINKS are made for AWG conductor sizes 26 thru 10. Send us a sample of your wire—we'll send you an installed SEALINK plus full details on this new method for making insulated, sealed splices.

**BURNDY**

NORWALK, CONNECT.

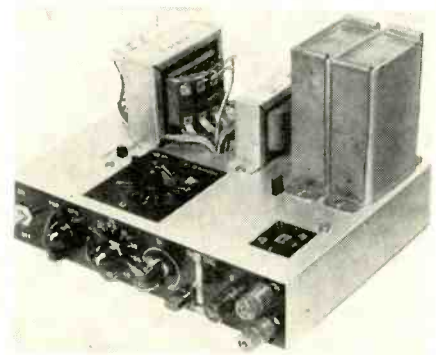
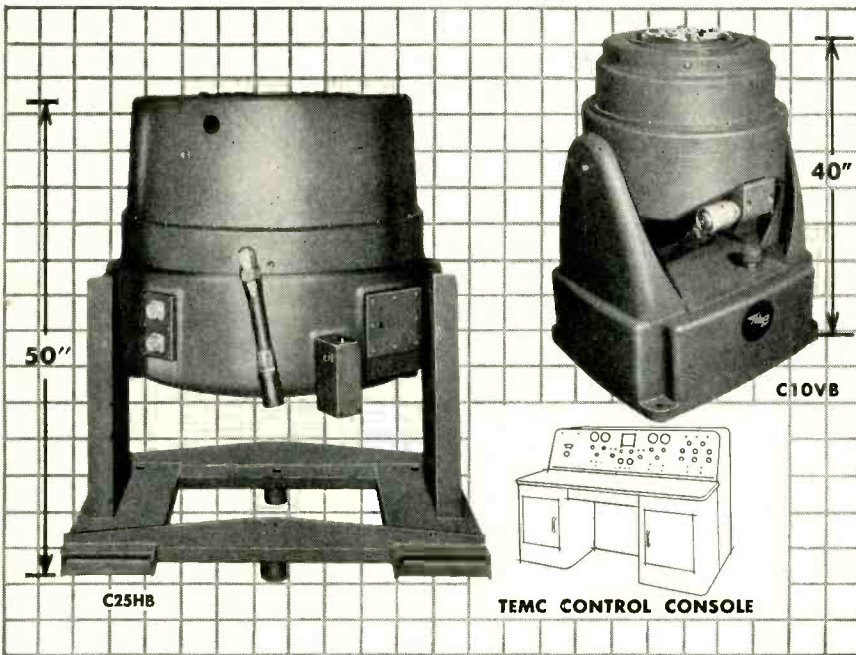

Photograph of the curve tracer shows layout of parts

# Vibration Testing cuts product development time

Testing components and structures with electrodynamic vibration exciter systems cuts research and development time in aircraft and missile systems. Often within hours, or minutes, the effect of service vibration can be pinpointed.

MB has perfected shaker systems that permit testing to all required specifications, enable engineers to speed product development from blueprint to prototype to production.

## COMPLEX MOTION TESTING

Several MB Exciter Systems reproduce complex and random motions. They can subject products to the actual service vibration. The Model C10VB Shaker shown offers the widest frequency range for its force. Model C25HB provides higher forces for higher "g."

## ENVIRONMENTAL TESTING

Both the above shaker systems can be used with environmental chambers . . . for "high altitude" and high or low temperature vibration testing. Oil cooled, they don't affect chamber vacuum.

## SPECIFICATIONS

**MB C10VB System provides . . .**  
 10 "g" on table loads to 145 lbs.  
 20 "g" on table loads to 57.5 lbs.

<b>Force output:</b>	<b>Band width:</b>
1750 lbs. Sine	5-5000 cps
1050 lbs. RMS	15-2000 cps
3150 lbs. Peak	15-2000 cps

**MB C25HB System provides . . .**  
 10 "g" on table loads to 422 lbs.  
 20 "g" on table loads to 172 lbs.

<b>Force output:</b>	<b>Band width:</b>
5000 lbs. Sine	5-2000 cps
3500 lbs. RMS	15-2000 cps
10,500 lbs. Peak	15-2000 cps

In meeting your requirements, MB offers you advanced designs . . . plus quality construction of shaker, amplifier and control system . . . plus an experienced field service organization.

**MB manufacturing company**

A DIVISION OF TEXTRON, INC.

1075 State Street, New Haven 11, Connecticut

HEADQUARTERS FOR PRODUCTS TO ISOLATE . . . EXCITE . . . AND MEASURE VIBRATION



kilohm resistor shunted by a 2- $\mu$ f smoothing capacitor in series with the base current supply, and followed by a 1N432 shunt-rectifying diode. The required polarity of this diode and of the collector supply rectifying diode depends upon whether the transistor is *nnp* or *pnnp*. A four-pole two-position reversing switch is set according to the type of transistor to be tested.

Setting of the 2.5-kilohm potentiometer controls the amplitude of swing of the bias current. The voltage across the 10,000-ohm resistor and base-emitter resistance of the transistor indicates instantaneous base current.

► **Calibration**—A calibration switch is so arranged that the terminals leading to the oscilloscope are normally connected to the 1,000-ohm resistor in the collector circuit and the 10,000-ohm resistor in the base circuit. The oscilloscope spot then traces out the  $i_c - i_b$  curve. When the switch is depressed and calibration control is set to zero, the  $I_c$  terminal is connected to ground. The oscilloscope spot then traces out the X-axis. When the switch is raised,  $I_b$  is connected to ground and the spot traces out the Y-axis.

A reference voltage for calibration is produced across a symmetrical type 1N429 Zener diode by applying a 6.3-v sine wave to it through a 300-ohm resistor. The diode limits at plus and minus 6 volts, so a squared sine wave appears across it having a regulated amplitude of 12 volts. This voltage is applied across a 2.5-kilohm potentiometer that feeds to the calibration switch. The potentiometer is scaled for both  $I_c$  and  $I_b$ . When



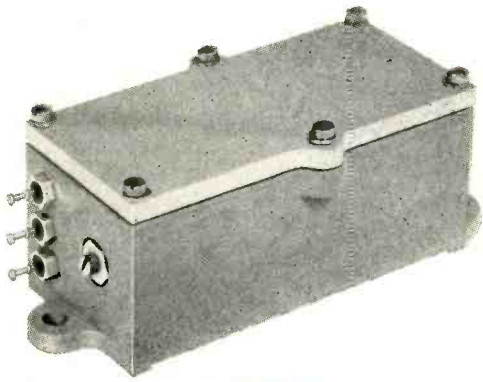

A line of accelerometers has been announced by the Components Division of Fairchild Controls Corporation. The unit shown—designated Type 940—is now being built for a toss bombing control system for the U.S. Air Force. These accelerometers have been developed with the same exceptional accuracy and reliability found in the complete Fairchild line of precision components: pressure transducers; linear and non-linear, single and multi-turn potentiometers; FilmPots® and trimmers.

## **NOW!**

# **ACCELEROMETERS**

**featuring Fairchild accuracy and reliability**

Fairchild's new line of accelerometers will accurately measure a wide range of static or uniformly-varying types of acceleration. Applications include flight testing, air-borne telemetering and computing, and measurement of maneuvering accelerations of missiles and aircraft. Variations of conformation, G-range, natural frequency and damping can be developed to meet special customer requirements. Damping is accomplished by the viscous shear action of the mass in an oil medium.

Over-all accuracy, including linearity, hysteresis and repeatability, is better than 1.5%. The Type 940 (shown above) will operate under ambient temperatures of  $-55^{\circ}\text{C}$  to  $100^{\circ}\text{C}$  and will withstand vibration in the order of 10-55cps .030" double amplitude and 55-500cps at 5G in each of the three axes. Whatever your precision component requirements, whether potentiometers, pressure transducers or accelerometers, you can rely on Fairchild's complete line and advanced engineering for the best answer. For information, write to: Dept. 140-87A, Fairchild Controls Corporation, Components Division.

**EAST COAST**  
225 Park Avenue  
Hicksville, L. I., N. Y.

**WEST COAST**  
6111 E. Washington Blvd.  
Los Angeles, Calif.



**FAIRCHILD**  
**PRECISION POTENTIOMETERS**  
**and COMPONENTS**

From  
"figures of  
speech"

to  
"conversation"  
piece

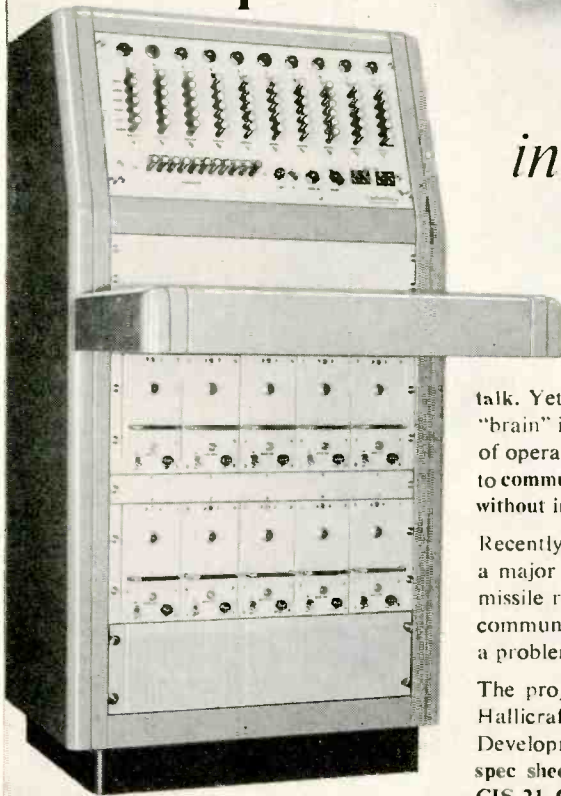

in 53 days  
with RDA\*

One of the few things today's large electronic computer cannot do is talk. Yet the product of its fantastic "brain" is useful only when hundreds of operators and researchers are able to communicate with perfect teamwork, without interruption or interference.

Recently Hallicrafters was asked by a major firm engaged in guided missile research to devise a superior communications system to solve such a problem. The need was urgent.

The project was assigned to Hallicrafters \*RDA Division (Rapid Development Assistance). From spec sheet to finished product, the CIS-21 Computer Intercom System was designed, built and delivered in exactly 53 days.

Through more than 1,000 practical combinations of ten amplifiers, the CIS-21 provides instantaneous and perfect communication between 250 remotely stationed individuals or groups. An outstanding feature is a matrix switch that guarantees constant output regardless of the number of amplifiers in use.

Whatever your problem may be in electronics production, development or research, Hallicrafters RDA is a talking point worth considering. For information, contact us today.

The  
**hallicrafters**  
Company

4401 West Fifth Avenue  
Chicago 24, Illinois

the calibration switch is depressed or raised and the calibration control is set to other than zero, the X or Y axis line appearing on the oscilloscope is broadened into a cyclic trace, the vertical or horizontal limits of which are displaced by precisely the amounts indicated on the calibration control.

The curve tracer in its present compact form is useful for comparing the current gain factors of different transistors or of various transistors in a batch of the same type. The change of current gain with operating point is immediately observable. The a-c value for  $\beta$  is the slope of the tangent to the trace, while the d-c value for  $\beta$  is determined from the co-ordinates of the trace point with respect to the origin.

Provided only curve shape is required, and fixing of the origin is not required, an oscilloscope with a-c amplifiers can be used.

Absolute accuracy of the calibration can be no better than 10 percent. Input resistances to the transistor base will vary with operating point and between transistors and comprise an unknown resistance (in the order of 1,500 ohms) in series with the 10-kilohm resistance upon which the current calibration is dependent. The resulting error will be greatest at very low values of  $I_b$ .

The stability factor of the testing circuit is not low and was designed this way for simplicity. For this reason it can be expected that the value of  $I_{co}$  will be augmented  $\beta$  times in its effect upon collector current. This effect is not likely to cause instability in the transistor except at extremely high operating powers or in high ambient temperatures.

## Pulse Attenuators for CRO Displays

By H. BRUCE McFARLANE

Radiation Laboratory  
University of California  
Livermore, Calif.

SIGNALS of wide voltage range and high frequency require development of a new technique of pulse measurement. It is desired to obtain



**DRIVER-HARRIS ALLOYS AT WORK IN PRODUCT ADVANCEMENT**

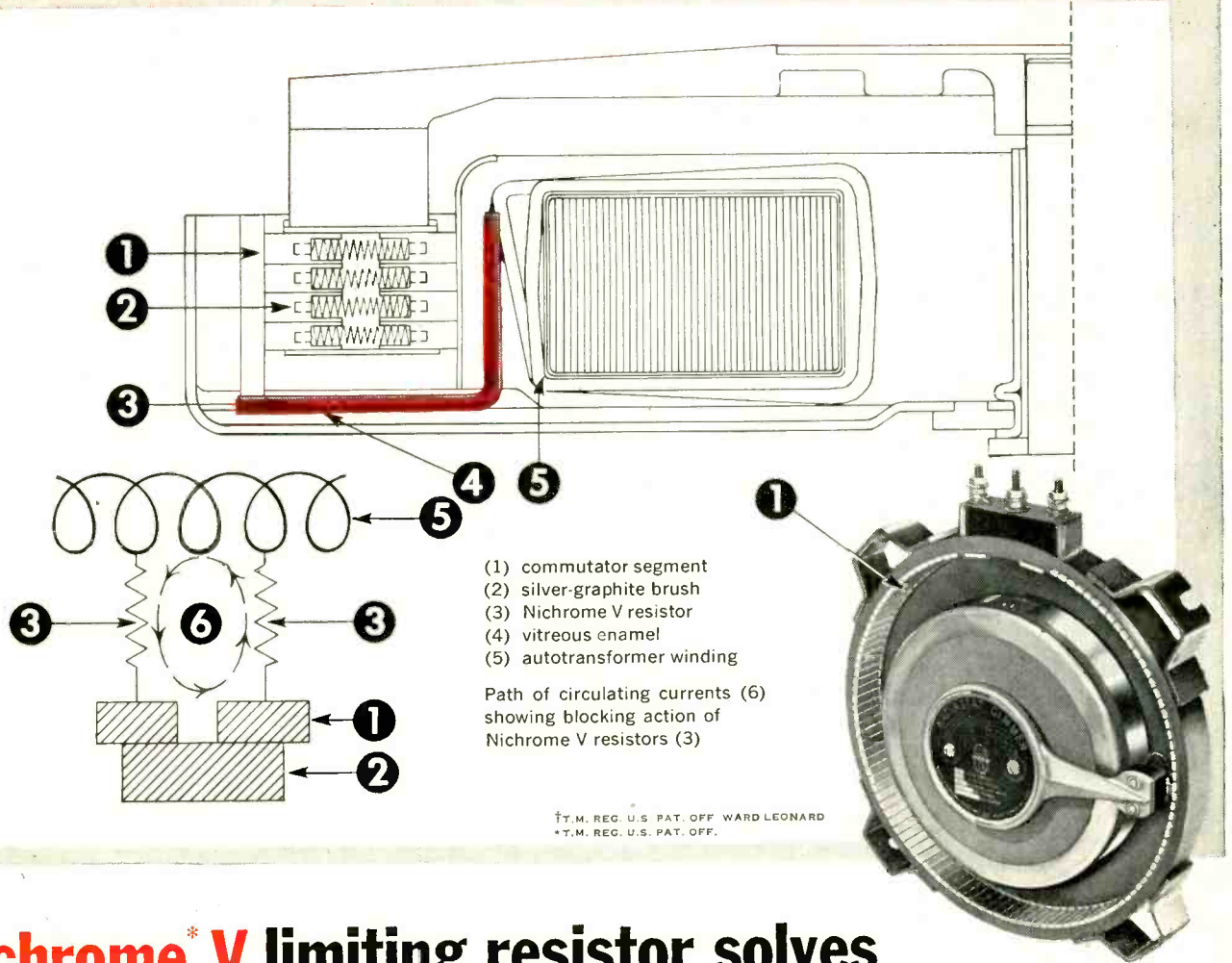

(1) commutator segment  
 (2) silver-graphite brush  
 (3) Nichrome V resistor  
 (4) vitreous enamel  
 (5) autotransformer winding  
 Path of circulating currents (6)  
 showing blocking action of  
 Nichrome V resistors (3)

†T.M. REG. U.S. PAT. OFF. WARD LEONARD  
 \*T.M. REG. U.S. PAT. OFF.

# Nichrome<sup>®</sup> V limiting resistor solves age old brush problem in Ward Leonard Dimmers

This Ward Leonard 6.6 KW Radiastat<sup>†</sup> Dimmer is essentially a specially designed core type autotransformer whose output voltage is linear, furnishing smooth, stepless control from maximum to zero. Other notable features are: Highest rating in smallest size and longer, maintenance-free life.

Nearly all adjustable autotransformers depend upon carbon brushes to limit the short-circuiting current which occurs whenever the brush straddles two segments. However, in the Radiastat Dimmer, circulating currents are kept to a minimum in a unique way, permitting use of self-cleaning, self-lubricating, low resistance silver-graphite brushes.

In the Radiastat, each segment is electrically connected to its respective turn of the winding through a Nichrome V current limiting resistor. During commutation, the main winding is protected against burnout from high short-circuiting currents, thereby eliminating external resistors or high resistance brushes.

These all important resistors (one for each segment) connect to the segments beneath the vitreous enamel and run out and up to connect with the winding. They protect every step of the Radiastat, regardless of the contact arm position—drop a penny or a nail across adjacent segments—there's no pouff! no burnout! The Nichrome V circulating current resistors completely safeguard the unit.

Nichrome V is used because it supplies a specified ohmage in a #10 wire 3<sup>3</sup>/<sub>16</sub>" long; bonds well with the vitreous enamel; is highly resistant to heat and corrosion, and easily withstands severe current surges.

Driver-Harris now produces 132 different high nickel alloys in many different forms and in hundreds of sizes for almost every kind of industrial application. Do you need help with a special alloy? Tell us about it and if we haven't got it, we'll develop it for you.



## Driver-Harris<sup>®</sup> Company

HARRISON, NEW JERSEY • BRANCHES: Chicago, Detroit, Cleveland, Louisville  
 Distributor: ANGUS-CAMPBELL, INC., Los Angeles, San Francisco • In Canada: The B. GREENING WIRE COMPANY, Ltd., Hamilton, Ontario  
 MAKERS OF THE MOST COMPLETE LINE OF ALLOYS FOR THE ELECTRICAL, ELECTRONIC, AND HEAT-TREATING INDUSTRIES

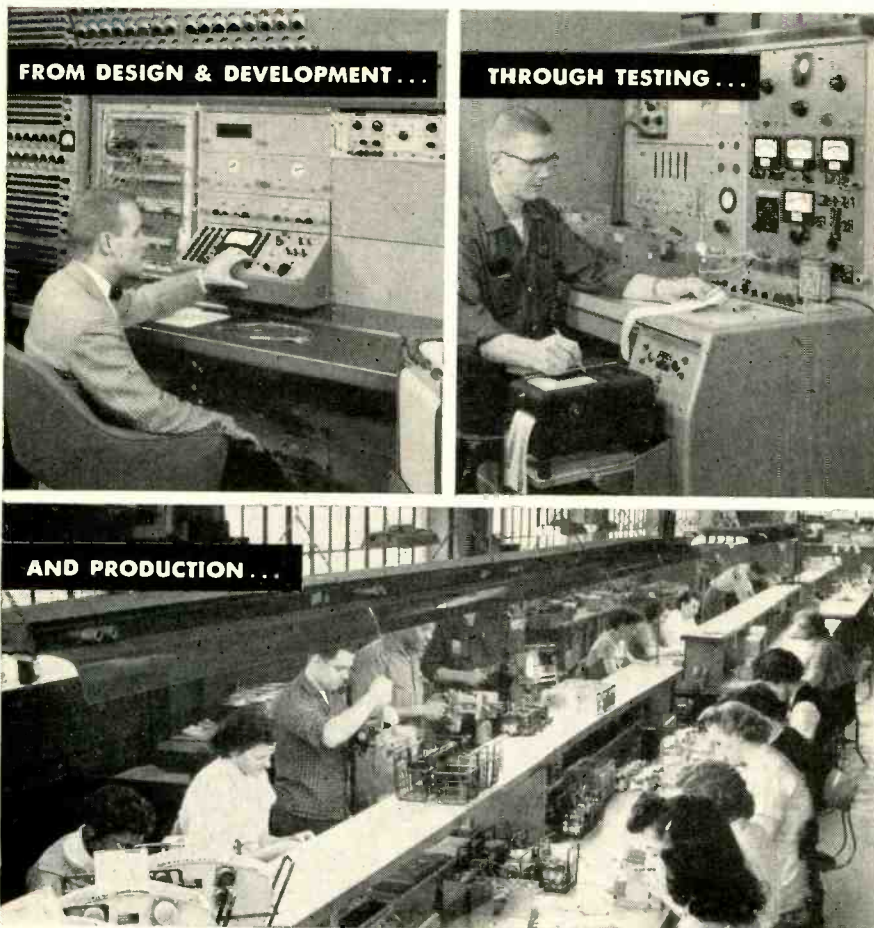

## ELECTRONIC CONTROLS

### For Aircraft and Missiles

Thompson experience, skills and facilities—from design through production—are ready to go to work for you. You can count on Thompson for development and production of electronic control sub-systems and components, countermeasures and microwave components. We invite your inquiries.



Aircraft Controls

Missile Controls

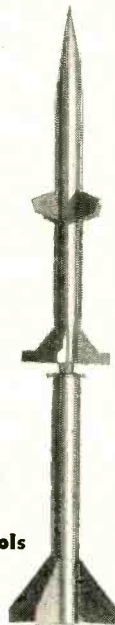

Visit our Booth #920  
at Wescan



ELECTRONICS DIVISION

**Thompson Products, Inc.**

2196 CLARKWOOD ROAD • CLEVELAND 3, OHIO

information from a single pulse in regions from  $10^{-4}$  to  $10^3$  volts by means of cathode-ray tube displays. The signal-level range in which a cathode-ray tube can satisfactorily operate is from 5 to 100 volts. It is evident that a large number of presentations would be necessary to display the signal over such a wide dynamic range. To reduce the number of oscilloscopes, tests were made to determine if a nonlinear attenuator could be built that would attenuate the high voltages more than the low voltages, thereby essentially compressing the signal.

This report deals with the design and performance of a termination,

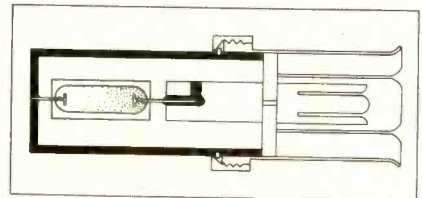

FIG. 1—Coaxial terminating resistor

a linear attenuator and a nonlinear attenuator.

A terminating resistor for pulse lines must be capable of withstanding repeated application of pulses having amplitudes of 1,000 volts and durations of  $1 \mu\text{sec}$ , without change in its electrical characteristics.

The impedance should be a nominal 50 ohms. The vswr should not exceed 1.04 from d-c to 300 megacycles. The length of the termination should be no more than 3 inches and its diameter not more than 1 inch.

Film-type resistors, although good from a frequency standpoint, will not stand the high pulse voltage. The Allen-Bradley 2-watt molded-carbon resistor has been used in the past without any special geometry of shielding and is able to hold voltage. The General Radio type 874 coaxial connector was used because of its ease of connection, the fact that it is a hermaphroditic connector and because of a vswr of less than 1.01 up to 1,000 mc. Figure 1 shows a cross-sectional drawing of the termination.

Considerable difficulty has been experienced in soldering molded-



# RELIABILITY ASSURANCE

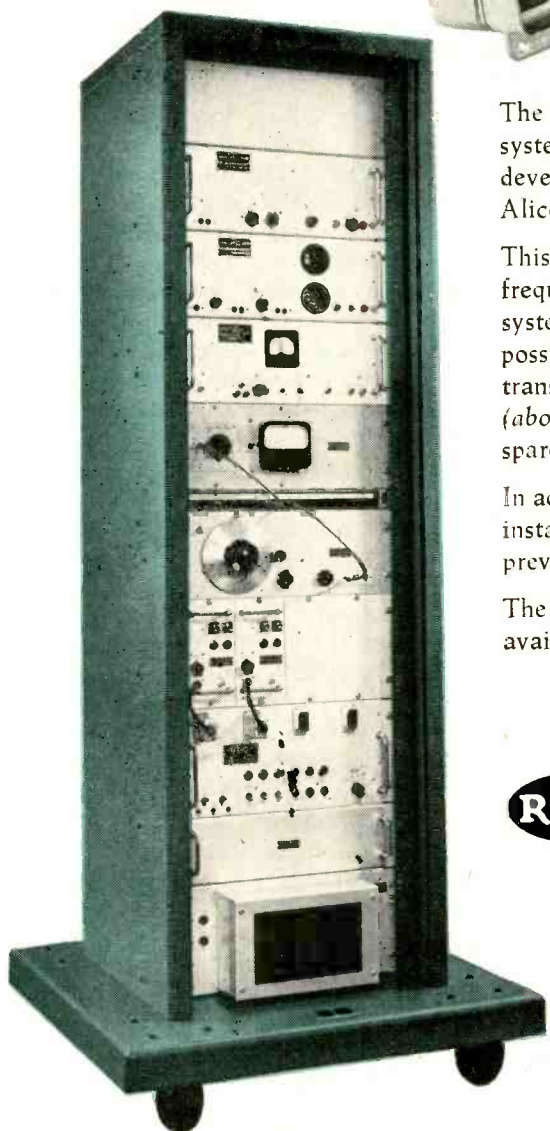
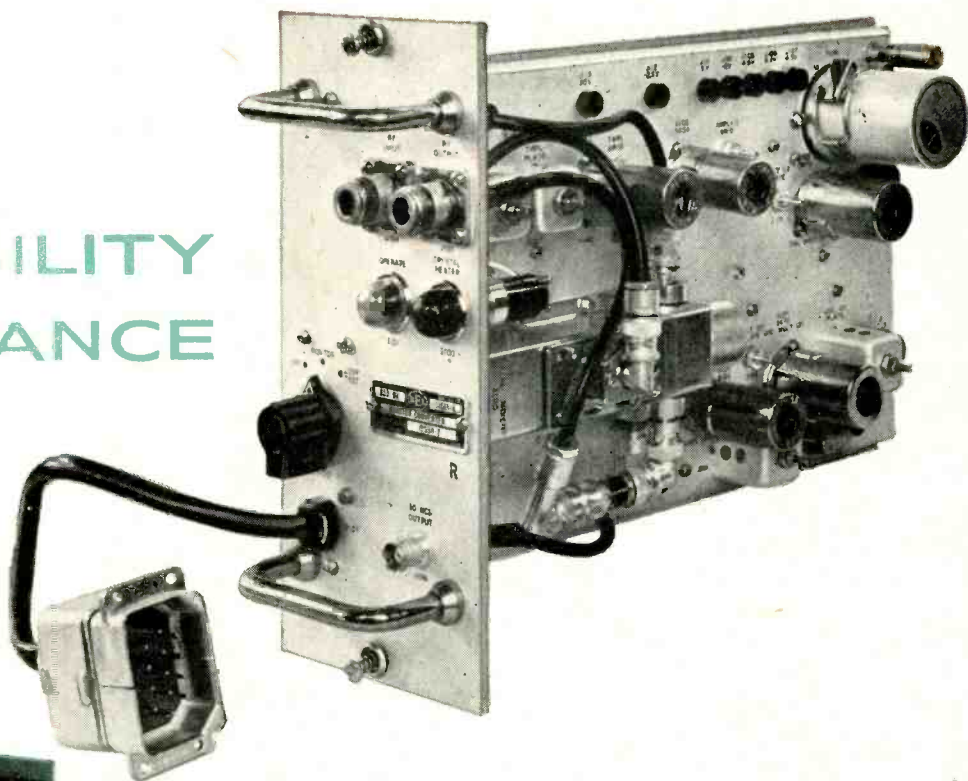

The operating reliability of White Alice, largest tropo scatter system yet conceived, is of the utmost importance. REL, which developed and manufactured all scatter radio equipment for White Alice, has also devised the easily movable test bay (left).

This bay permits system level settings to be made, measures system frequency response, and enables noise loading tests which measure system intermodulation of two or more stations. It also makes possible precise measurement of carrier frequency while the transmitter is in service. The incorporated monitor converter (above) provides a loop between a station's spare transmitter and spare receiver for all of the above tests.

In addition, any panel from transmitter exciters or receivers can be instantly inserted in REL's unique test bench, pictured in a previous advertisement, for complete measurement and testing.

The skills and experience which achieved these solutions are also available for your specialized radio problem.



**Radio Engineering Laboratories, Inc.**

36-40 37th St • Long Island City 1, NY

STillwell 6-2100 • Teletype: NY 4-2816

Canadian representative: AHEARN & SOPER CO • 384 BANK ST • OTTAWA

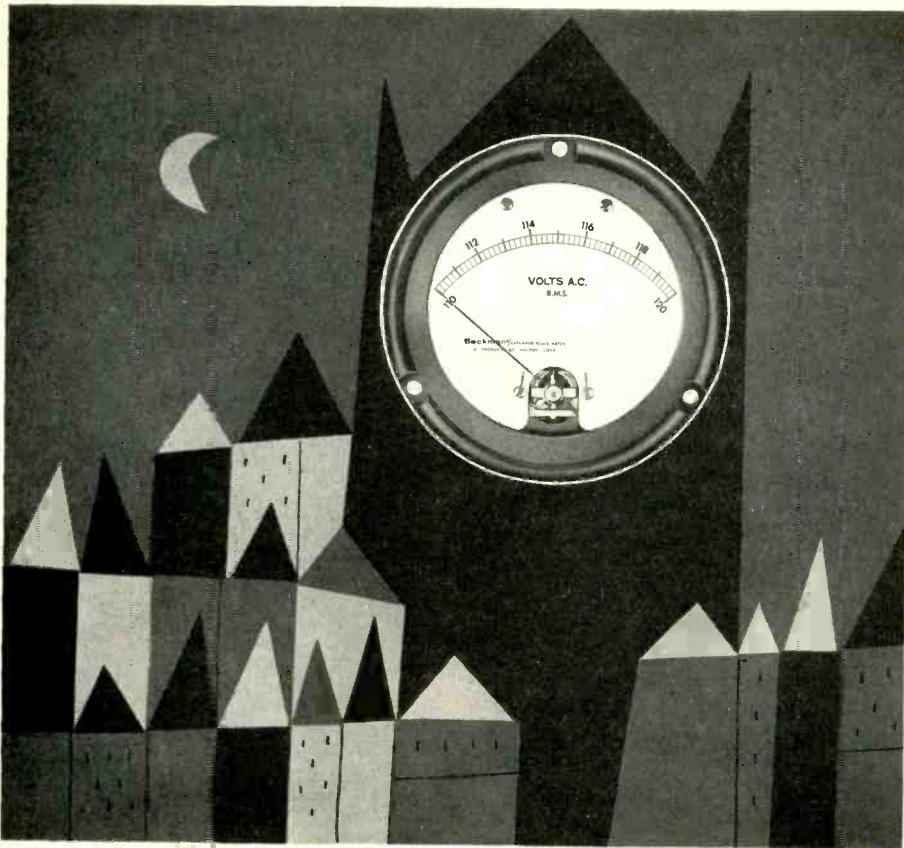

*When you're on the run, and there's barely time for the hastiest over-the-shoulder glance, Beckman Expanded Scale Voltmeters read*

# right at a glance

BECKMAN EXPANDED SCALE VOLTMETERS read accurately from any angle, under the most hair-raising conditions of distance, darkness and distraction.

HOW COME? Because the useful portion of the scale is expanded and the rest tossed out. No befuddling bunched-up divisions at one end of the scale, as in conventional meters.

THE RESULT? Accuracy to 0.3% of center-scale voltage. Resolution to 0.1 volt. Readability to 20/400 vision.

THE FACTS? Beckman Expanded Scale AC & DC Voltmeters are for panel installations down on the ground, up in the wild blue yonder, or for test equipment anywhere. The eight basic models come in shapes, sizes, standard scales and accuracies to suit your installation.

OTHER QUESTIONS? Write for data file 84A.

**Beckman** / **Helipot**  
Corporation

Newport Beach, California  
A division of  
Beckman Instruments, Inc.  
Engineering representatives  
in principal cities

1171

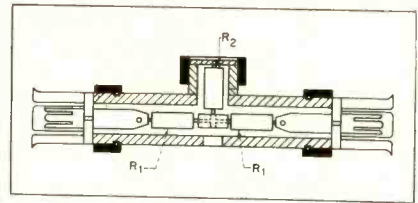

FIG. 2—Housing for linear attenuator

carbon resistors with short leads. Empirical data on the behavior of these resistors with temperature changes has been difficult to compile because of erratic behavior. In general, however, it can be stated that molded-carbon resistors of the type used are characterized by a resistance change with change in temperature as follows:

(1) As the temperature is increased the resistance increases.

(2) As temperature increase is halted resistance increase halts.

(3) As temperature is decreased to initial value, resistance decreases to a value that is higher than the initial value of the resistance.

(4) Further increases in temperature that do not exceed the previous highest temperature reached by the resistor (as in (2)), allow the resistance upon cooling to return to the value noted in (3).

(5) Further temperature rises, wherein the temperature exceeds the previous highest value reached in (2), cause the resistance upon cooling to be greater than that in (3).

Exceptions to the above have been noted in that an occasional resistor will display erratic changes of resistance with increase in temperature. It has been possible to utilize this behavior of molded-carbon resistors in the construction of all three devices mentioned in this report. Inasmuch as leads on the resistors, if left long, contribute an excessive amount of inductance to the devices, it has been found necessary to curtail the length of the leads to somewhere in the neighborhood of 0.1 inch.

To ascertain that the resistors which are to be soldered into the termination do not fall outside the tolerances established, it is necessary to specify to the supplier that the resistors come from the 0.95 to 0.99 sides of the nominal 47-ohm range. Upon heating as they are



Wescon

See you at Aug. 20-23

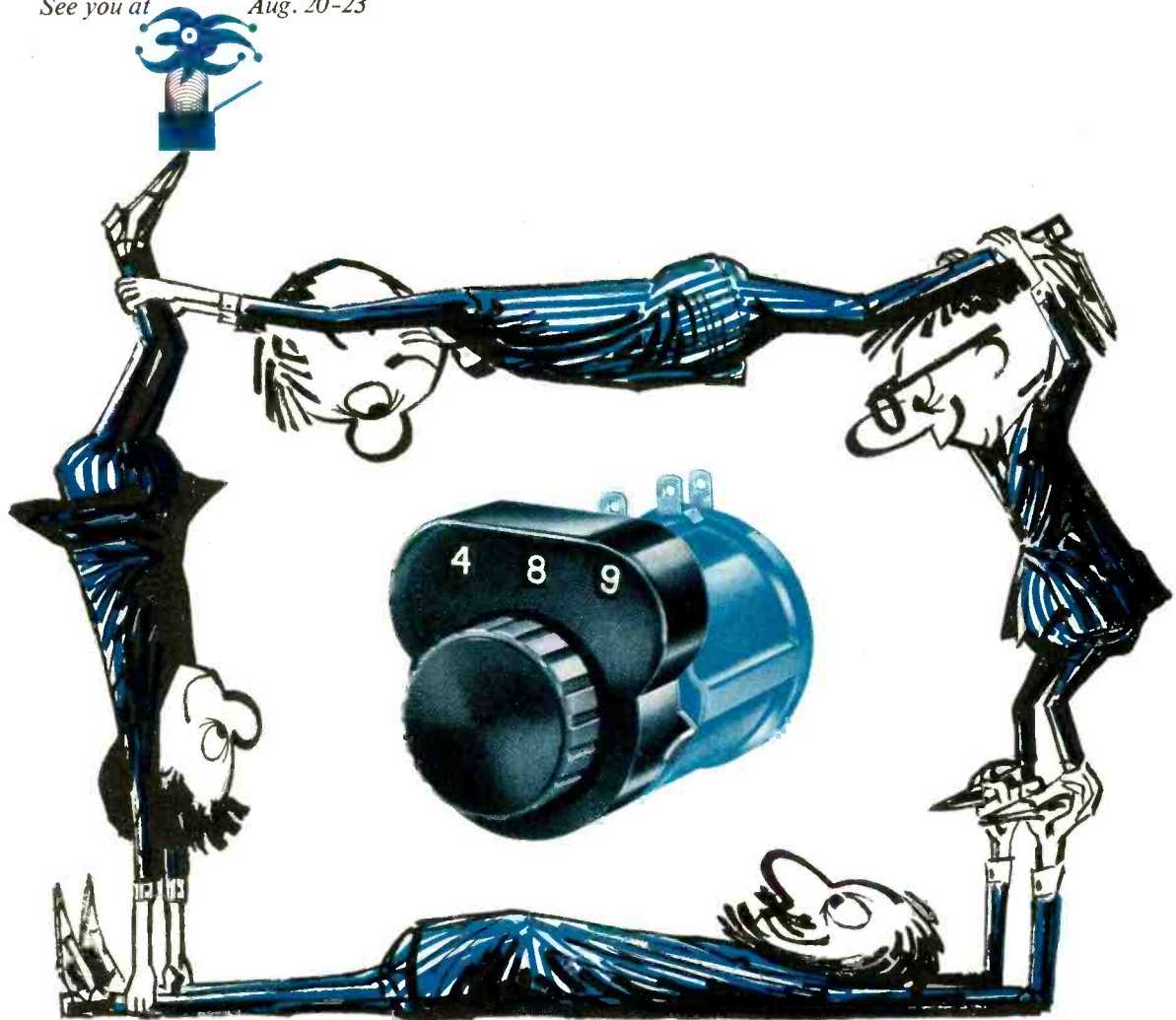

## A Dial to reckon with

When position is everything, you can count on the new DIGIDIAL\* ten-turn decimal-counting dial... for indicating shaft position from  $0^{\circ}$  to  $3,600^{\circ}$ ... with reading resolution of 0.05% of full scale or better.

The DIGIDIAL reads by the numbers. This means farewell to interpolations and operator errors... hail and hello to fast, accurate reading from as far as six feet away... from just about any angle except behind the panel. You'll welcome its compact construction, light weight, simple installation and smooth operation. You'll utter gleeful greetings to the positive, non-distorting locking mechanism.

If position is important to you, you'll want to know more about the DIGIDIAL... to get the whole story, write for data file 82A.

Beckman®

**Helipot** Corporation: Newport Beach, California

a division of Beckman Instruments, Inc.

Engineering representatives in principal cities

1163\* ®Trademark

# HALLIBURTON

## ALUMINUM CASES

FOR INDUSTRIAL AND MILITARY USE  
PRECISION-MADE TO SPECIFICATION



### MILITARY CASES

(per Joint Military Specifications) for Air Force, Navy, Army and other military branches' applications. Halliburton Series 120H.

Water-air tight, shockproof. Available in all sizes. Reusable storage, shipping and carrying cases for Aerial Cameras, Aerological Equipment, Electronic Controls, Radio Devices, Navigation Instruments, etc. Requires no special packaging or crating.

### INDUSTRIAL and MILITARY CARRYING CASES



Weather tight—lightweight. Available in various sizes, complete or without interior details to your specifications. Series 100X.

Applicable for enclosure of Electronic Controls, Radio Devices, Cameras and Equipment, Aerological Equipment, Navigation Instruments, Medical Apparatus, etc.

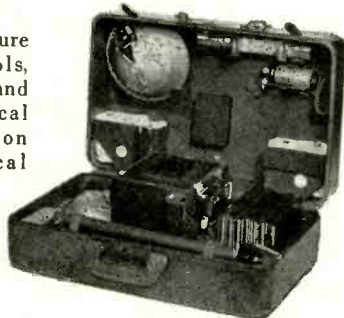

For further information write to

**HALLIBURTON, INC.**  
4724 South Boyle Avenue, Los Angeles 58, California  
Telephone: LUdlow 8-3181

soldered into place, they usually fall within the 48- to 52-ohm limit required.

The linear attenuator must attenuate pulses having an amplitude of 1,000 volts and durations of 1  $\mu$ sec and input impedance should be 50 ohms when the attenuator is terminated in 50 ohms. Size should not exceed 1 in. diameter by 6 in. in length.

The 50-ohm attenuator is made using the same type of molded-carbon resistor. The electrical circuit used is that of a balanced tee attenuator. For accurate calibration, however, the attenuator is marked as input on one end and tested to determine its exact attenuation.

It can be shown that the values of resistors required in the two arms and the leg of a tee attenuator are represented by the following formulas:

$$R_1 = Z_0 \frac{K - 1}{K + 1} \quad R_2 = Z_0 \frac{2K}{K^2 - 1}$$

where

$K =$

$\frac{\text{current in load resistor without attenuator}}{\text{current in load resistor with attenuator}}$

$Z_0 =$  characteristic impedance of line

$R_1 =$  resistance of each of the two arms of the tee

$R_2 =$  resistance of leg of the tee

Table I shows the theoretical resistance values required for the attenuators as well as the nominal 5 percent resistor values actually used. These resistance values are automatically adjusted by the heat used in soldering them into place.

Measurements of  $Z$  and  $\theta$  were made on a vhf bridge with the attenuator terminated in 50 ohms. Using the bridge measurements as a guide, attenuator housings having a variety of configurations were constructed and tested. A cross section of the housing having the most favorable characteristics is shown in Fig. 2. Field tests have

Table 1. Resistance when  $Z_0$  is 50 ohms

Approximate attenuation in db	Ultimate value after heating		Nominal value	Nominal value
	$K$	$R_1$ $R_2$		
10	3	25    37	24	26
14	5	33    21	33	20
20	10	41    10	39	10



Design Problem:

# 226 Control, Power and Instrumentation CIRCUITS

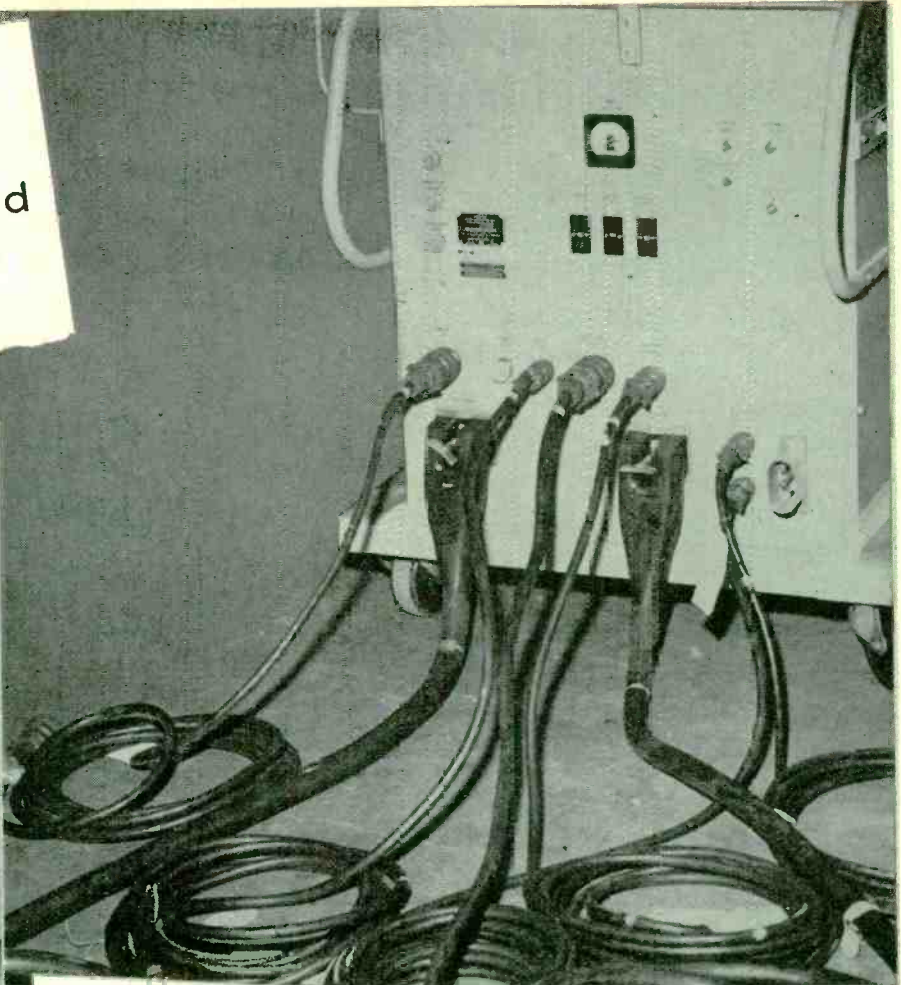
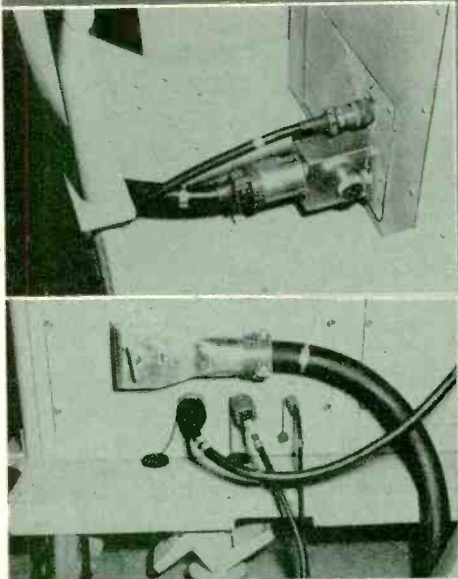

## SPECIFICATIONS

### ELECTRICAL

Capacitance load within cable held to 40 uuf/ft • Cross talk attenuated to a 40 db level • Voltage breakdown 3000V • Leakage resistance 75 megohms/1000 ft. maximum • Conductor sizes and types: #22; #22-TPSJ • Floating shields.

### PHYSICAL

Diameters:  $\frac{3}{4}$ " to  $1\frac{1}{32}$ " • Lengths: 2' to 1000' • Cable Configuration: 6, 9, 10, 12, 24, 41, 61 and 63 conductors •

### Connectors:

AN type A and B

Cannon DPD2

1) Molded 90° attachment

2) Metal back shell

} Each with mechanical engaging mechanism

Bend radius: Four times cable diameter, retaining flexibility at -65°F.

Conductors: Number coded every 2" inside of cable.

### ENVIRONMENTAL

Reliable operation from -65°F. to +200°F. Neoprene jacketed to withstand severe abrasion: trucks running over cable; dragging along rough ground; burial.

Resistance to oils, fuels, acids, liquid oxygen, fungus, ozone and sunlight.

Completely waterproof and submersible.

## Solution: 8 RELIABLE, COMPACT, VERSATILE PACIFIC AUTOMATION PRODUCTS Engineered Electronic Cables

The eight electronic cables installed on the above junction box comprise the 226 vital control, power and instrumentation circuits for check-out of the Chance-Vought REGULUS I MISSILE.

They were designed and manufactured by Pacific Automation Products who assisted development engineers in the design of this system — keeping the number of cables to a minimum, fulfilling the circuitry requirements, preserving functional versatility, and maintaining reliability under exacting operating conditions.

The criteria governing Pacific Automation Products' concept of a system design are as follows:

1) proven reliability; 2) maximum versatility; 3) minimum number of cables; 4) mutual interchangeability. This concept guarantees optimum performance and maximum reliability.

Pacific Automation Products' engineers give consideration to all contingencies in the design of the cable system; as an example, the electrical, physical and environmental conditions stipulated to the left, in the design of cables for the Chance-Vought REGULUS I GROUND SUPPORT SYSTEM.

*Engineers and technicians are invited to investigate career opportunities with us. Submit resume for interview.*

Engineering representatives will be pleased to discuss your design problems, when you visit them at Booth 159 — Air Power Panorama, Washington, D.C., July 31-Aug. 3; Booth 2412 — WESCON Show, San Francisco, Aug. 20-24.

For further information, write for Bulletin 158



**PACIFIC AUTOMATION PRODUCTS, INC.**

1000 Air Way, Glendale 1, Calif. • CHapman 5-6871—TWX: GLN7371

137 Walnut Hill Village, Dallas, Texas • FLeeewood 2-5806

420 Lexington Ave., New York 17, N.Y. • LEXington 2-5193



# 10 reasons why the STAT-TRAN® is specified

FOR PULSE COUPLING AND  
BLOCKING OSCILLATOR CIRCUITS

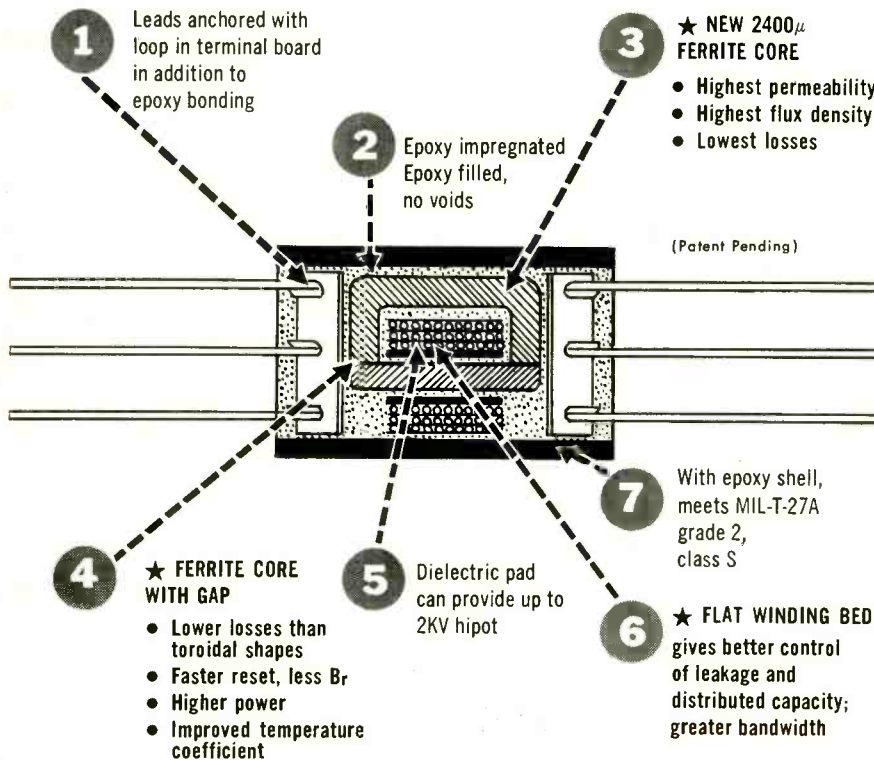

8 Small size — only 7/16" D x 3/4" L

9 Now available for immediate delivery

10 Lowest cost — (volume price only \$1.88 ea.)

## Save Engineering Manpower by using our Prototype Service

At today's engineering costs, if your engineer spends only 30 minutes designing and building a pulse transformer you are losing money. You could purchase a prototype Stat-Tran\* and still save! (Figured @ engineering costs of \$10.00 per hour and a prototype Stat-Tran\* @ \$4.60.)

## Write For New Pulse Transformer Catalog

Available now, your free copy of our new 12 page, 2-color catalog, giving complete technical specifications on pulse transformers and filters as well as outlining typical circuitry and applications.

# Pulse Engineering

REDWOOD CITY  
CALIFORNIA

2657 Spring Street

2 \*REG. TRADE MARK

shown that these attenuators are rugged and stand up well under both severe mechanical and severe electrical usage. For reliable operation, the average power dissipation should not exceed 1 watt.

The nonlinear attenuator must show attenuation to a 1,000-volt signal of 20 db, while attenuation to a 10-volt signal should be approximately 6 db. The attenuator should pass signals having a rise time of  $10^{-9}$  seconds and attenuation should be the same for signals of opposite polarity. Input im-

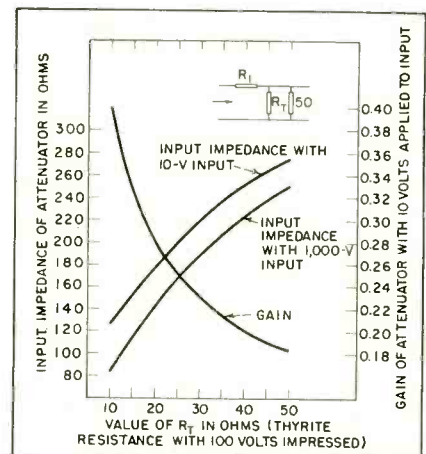

FIG. 3—Thyrite characteristics under varying conditions

pedance with 1,000 volts input should be 50 ohms.

Initial experiments on a suitable nonlinear material to be used centered around silicon carbide marketed by the General Electric Company under the trade name of Thyrite. This material is sold in various cylindrical sizes. The type ultimately chosen has a diameter of 0.5 inch and a thickness of approximately 0.06 inch. Thyrite has a negative resistance characteristic. Its resistance can be expressed by the following relation:

$$R_t = \frac{1}{K E^n}$$

where

$R_t$  = resistance of Thyrite at voltage  $E$   
 $E$  = applied voltage  
 $K$  = a constant (amperes at one volt)  
 $n$  = an exponent

The values of both  $K$  and  $n$  depend upon the dimensions and resistivity of the material used in the particular resistor in question. No two samples of Thyrite have identi-



# HUGHES GERMANIUM DIODES

*with high conductance  
and  
quick recovery, together*

Never before have the properties of high conductance and quick recovery been combined to this extent in one diode. For the first time, Hughes offers this unusual combination in a new series of germanium point-contact devices. They have the famous glass package created at Hughes, the same rugged construction which enables all Hughes diodes to withstand shock, vibration, and severe environmental conditions. But inside there are changes. And these changes, painstakingly developed and meticulously introduced into the manufacturing process, impart to the diodes their unusual characteristics—make them fill a need long recognized in the industry.

#### APPLICATIONS:

These diodes make possible advanced, higher speed circuits in which recovery from a forward pulse must be achieved in a minimum of time. Their low forward voltage drop combined with the fast recovery make them ideal for transistorized computer circuits and similar applications.

#### SPECIFICATIONS AT 25° C

Type	Forward Voltage Drop @ 10mA	Maximum Reverse Current @ -50V	WIV	Forward Current @ +IV
HD-2762	0.80V	50 $\mu$ A	80V	20mA
HD-2763	0.80V	100 $\mu$ A	80V	20mA
HD-2764	0.67V	50 $\mu$ A	80V	50mA
HD-2765	0.67V	100 $\mu$ A	80V	50mA

All types recover to 100 Kohms in 1  $\mu$ sec when switched from 30 mA forward to -85V reverse in the modified IBM "Y" test circuit.

If you plan to be in San Francisco for the Wescon show, please visit our booths (#2910-11 and #2912-13). Perhaps we can discuss the new diodes there and determine how to use them most effectively in your circuits. Or, if you prefer, ask for a visit from one of our sales engineers. Please write:

SEMICONDUCTOR DIVISION • HUGHES PRODUCTS • *International Airport Station, Los Angeles 45, California*

*Creating a  
new world  
with*  
ELECTRONICS

**HUGHES PRODUCTS**

HUGHES



SEMICONDUCTORS

© 1957, HUGHES AIRCRAFT COMPANY

# LIFE IS NO PROBLEM

WITH **TIC** PRECISION POTENTIOMETERS

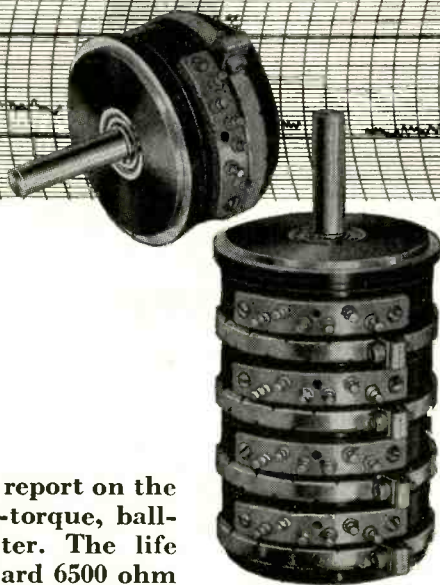
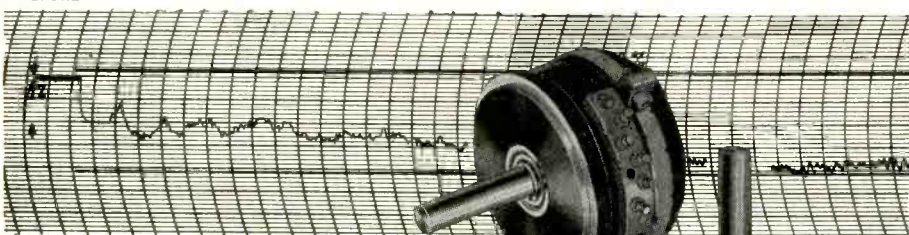
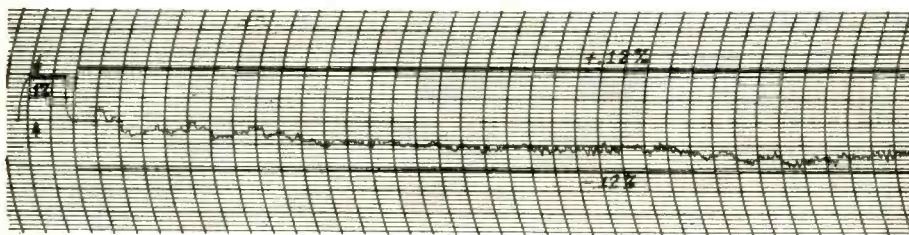

Take for instance a recent test report on the TIC Type ST20, a 2-inch, low-torque, ball-bearing precision potentiometer. The life test was conducted on a standard 6500 ohm unit. At 30RPM the ST20 was subjected to 700,000 cycles, reversing direction every 30 minutes. The linearity graphs shown above show the before and after of the ST20's independent linearity. *As can be seen, the linearity change is imperceptible.*

Some of the change in linearity after the life cycling can be attributed to change in effective resolution due to contact wear. Other results from the life test indicate less than 100 ohm equivalent noise resistance except for one spot, where it was less than 1000 ohms. The 1000 ohm spot was of such short duration that the linearity recording did not pick it up. **Test Summary: The ST20 will perform with only infinitesimal degradation for over 700,000 cycles.** If it's long life at full precision performance, that you want, specify precision potentiometers by TIC.

## TECHNOLOGY INSTRUMENT CORP.

569 Main Street, Acton, Mass. COLonial 3-7711  
West Coast Mail Address, Box 3941, No. Hollywood, Calif. POplar 5-8620

cal characteristics although all resistors of a given classification fall within a specified range. Both  $K$  and  $n$  vary from sample to sample.

Assuming a simple L-type attenuator, it can be seen that the nonlinear element must fall in the shunt-leg rather than in the series leg to produce the desired characteristics. Since it is required that the upper limit of output voltage be 100 volts, the Thyrite resistors are measured at this voltage.

Dissipation in the Thyrite resistor will exceed the continuous power rating of 0.1 watt if direct current is applied.

Actual measurements with a simple pulser showed that most samples were within the range of from 10 to 50 ohms with 100 volts applied. A simple attenuator consists of a series resistor leg and a shunt Thyrite leg. The output is shunted by the 50-ohm transmission line or terminating resistor. The three curves of Fig. 3 show the Thyrite resistance with 100 volts applied versus: gain of attenuator with 10 volts input, input impedance with 10 volts input and input impedance with 1,000 volts input.

The curves show that even if all the Thyrite units are selected in

## Ultrasonic Surgery



Transducer heads for ultrasonic unit being perfected for brain surgery are inspected by William J. Fry of the bioacoustics laboratory at the University of Illinois. Conditions previously considered inoperable can be treated by focussed ultrasonic beams



# Tuning Fork Controlled

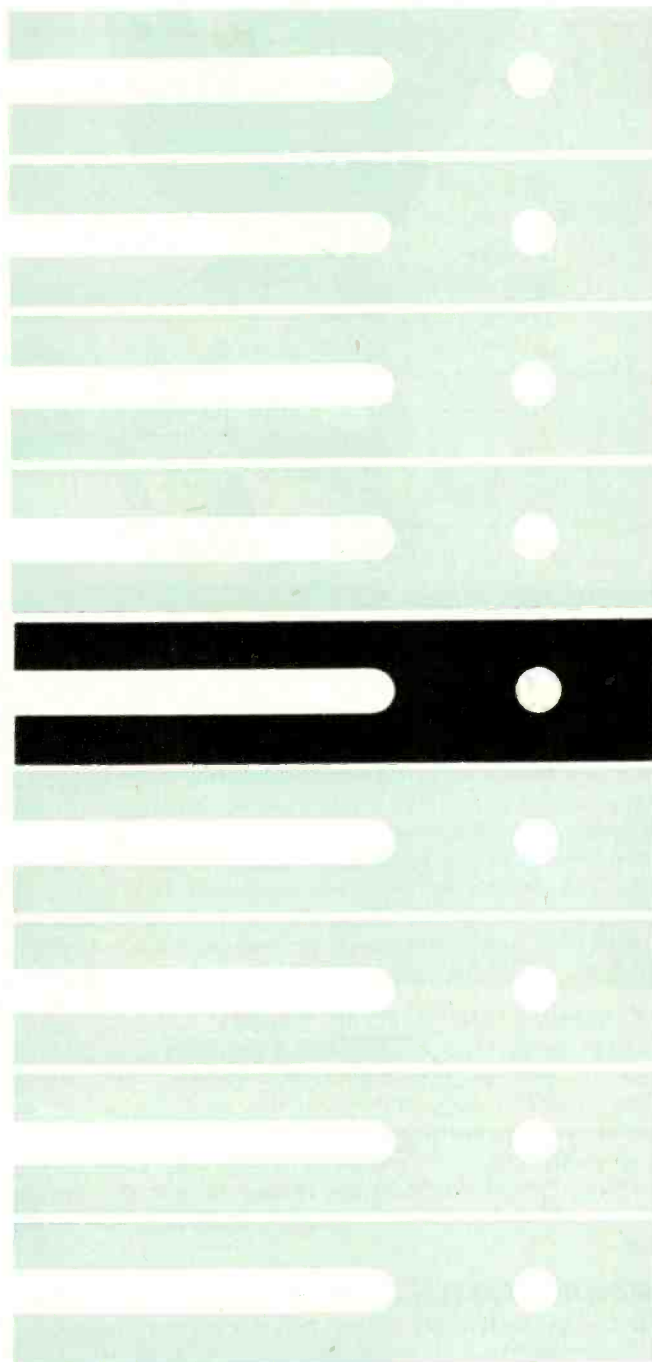

Tuning Fork Resonators, the ultimate in precision audio frequency control.

**PHONE OR WRITE**

for complete information regarding component type Tuning Fork Resonators, and variously packaged Frequency Standards, Oscillators, Drivers, and Frequency Dividers.

**PHILAMON LABORATORIES INC.**

90 Hopper Street, Westbury, Long Island, N. Y. EDgewood 3-1700

Circle 131 Readers Service Card

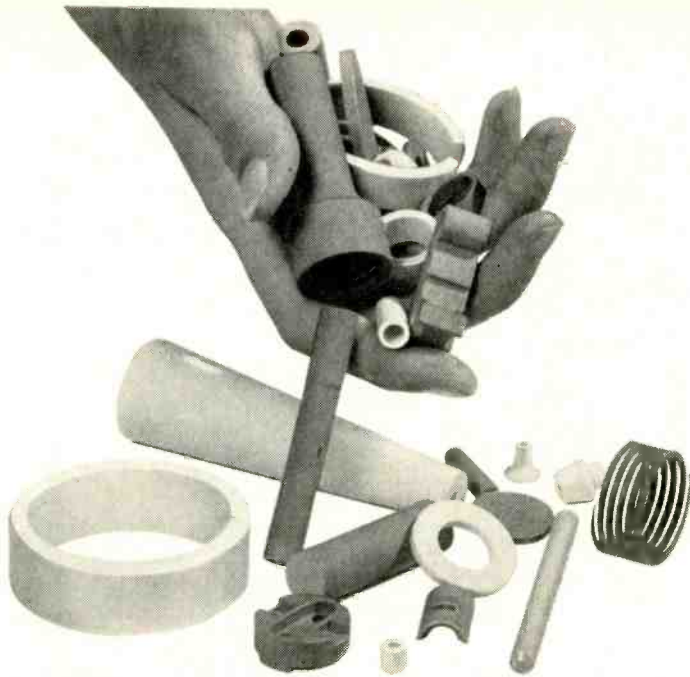

two special services on  
**DIAMONITE** *high alumina parts*

to speed up your production or development work

- **PROMPT, 24 HOUR OFF-THE-SHELF SERVICE** from large, comprehensive carefully-controlled inventories of hundreds of precision DIAMONITE parts in different shapes and sizes . . . rings, cylinders, tubes and rods. You can adapt these standard parts to your specific projects . . . and get your ideas into production in a matter of days or weeks, instead of months. You will also be in a position to enjoy better deliveries and better costs, as well as better quality, when you are ready to go into production.
- **SPEEDY SERVICE ON SPECIAL SHAPES** in small lots from DIAMONITE'S complete, modern pilot plant. The shapes will be engineered to your submitted drawings. Delivery of parts will be made in a matter of days. This saves you three ways: (1) In time required to get your projects through the preliminary stages; (2) In saving on costly dies until you have tested your ideas and worked out the "bugs"; and (3) In time needed to get the project into production. Air mail your prints and specifications for prices and deliveries.
- **ALL DIAMONITE PARTS** — from inventory or from pilot plant — have all the properties for which DIAMONITE is famous. These include extremely low dielectric loss factors, high thermal shock resistance, high strength, high hardness, absolute zero water absorption, and many other desirable characteristics.

Start saving time and money now in developing your ideas. Send for a copy of the DIAMONITE OFF-THE-SHELF Inventory and Price List #357, or pick up your copy at

THE DIAMONITE EXHIBIT  
**BOOTH 2129**  
**WESCON SHOW**  
 San Francisco's Cow Palace  
 August 20, 21, 22, 23

**DIAMONITE**  
 products manufacturing company  
 pioneers in  
 the development of high  
 alumina ceramics  
 Canton 3, Ohio  
 Phone: GLEndale 6-8195

the range of 10 ohms, the attenuator still has a wide range of input impedance (83 to 125 ohms). Also, the output at 10 volts input is down 8 decibels.

An attenuator with better characteristics can be built if two stages are used instead of one. Since the mismatch criterion is actual volts reflected into the system rather than vswr at any particular voltage, it is evident that a better matching characteristic is desirable with 1,000 volts applied than with 10 volts applied.

The development work on the coaxial linear attenuator was done in collaboration with R. H. Rector. This work was performed under the auspices of the U. S. Atomic Energy Commission.

## Determining Grounded-Grid Operation

By FRANK AGRESTI  
 Applications Engineer  
 Ampere Electronic Corp.  
 Hicksville, N. Y.

EQUIPMENT designers are often required to determine grounded-grid operating conditions for which the method of calculation is not described in the popular reference books.

A simple method of making the

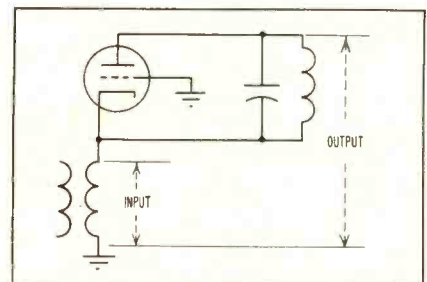

FIG. 1—Basic grounded-grid circuit

necessary calculations is described here. The determination is easily made from any set of the usual grounded-filament typical operating conditions and the characteristic curves published by the manufacturer.

This method may also be used to determine the grounded-grid con-



**Relay Sales**

Telephone Relays

Midget Relays

Keying Relays

Rotary Relays

Sealed Relays

Sensitive Relays

Latching Relays

Stepping Relays

Delay Relays

Timers

Contactors

Motor Starting Relays

Differential Relays

Polarized Relays

AN Approved Relays

Write for Catalog  
1957-C8

**Relay Sales**

# why wait for RELAYS

**LEADING MAKES-  
LATEST TYPES  
IN STOCK!**

AUTOMATIC ELECTRIC  
Type BQA and Many  
Others in Stock

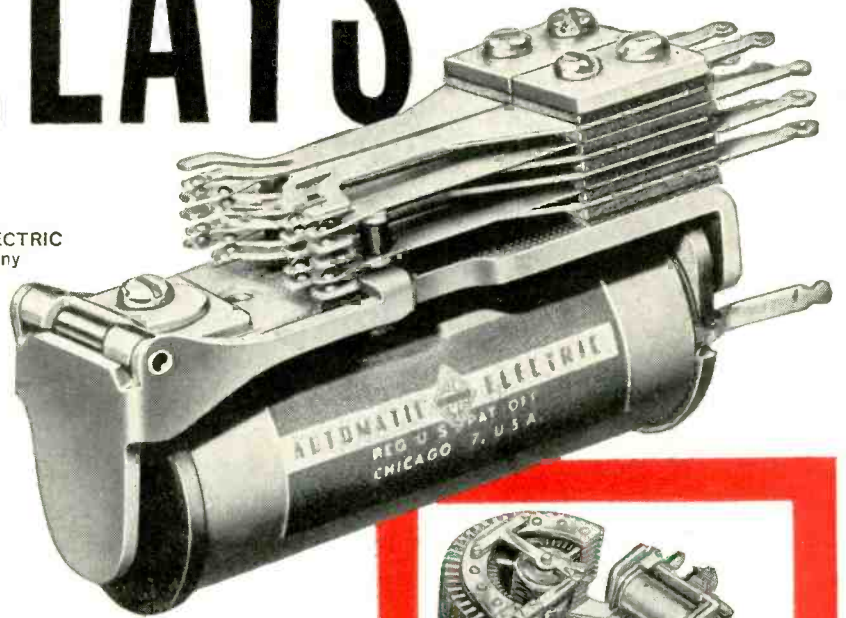

We maintain complete distributor stocks of the following makes:

Advance Relays	Phillips Controls
Automatic Electric	Struthers-Dunn
Clare	Leach Relays
Neomite-Elgin	Terado and Others

### We Anticipate Your Relay Needs

Relay Sales cannot get better delivery from manufacturers than you. Relays now in stock were ordered as long as 10 months ago and selected by men who have specialized in supplying relays to the industry for many years. The items illustrated are typical of hundreds of thousands in stock. They are available in all popular coil ratings and contact arrangements. Why wait for relays? Call us today!

Write or Phone for Same Day Shipment  
Phone: West Chicago 1100

**RELAY SALES, INC.**

P.O. BOX 186-A

West Chicago, Ill.

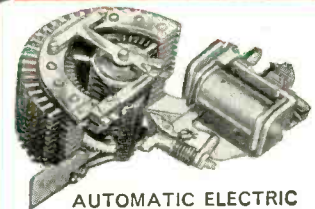

AUTOMATIC ELECTRIC  
Type 45 Stepper  
Wide Selection

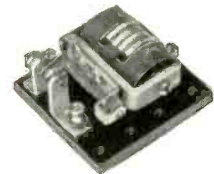

STRUTHERS DUNN  
Keying Relay  
Many Types in Stock

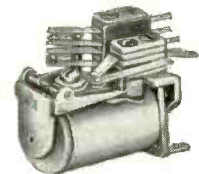

PHILLIPS CONTROL  
9QA Midget for Sub Chassis  
Mounting. Many Others  
in Stock



(Actual Size)  
NEOMITE-ELGIN  
Sub Miniature Hermetically Sealed  
Relay. All Advance Types in Stock

# "Just Doing a Little Exploring!"

If you're the man  
whose product needs  
this Tung-Sol Relay—  
then it's you I'm  
exploring for



Tung-Sol produces a line of thermal relays in the general operating range characterized by the Type 609. Snap action contacts and extremely sensitive actuating heater elements provide uniform cycling. Operating principle permits manufacture of time delay relays and relays which function on small differential of voltage and current. Compact and lightweight, Tung-Sol relays are ideal for instruments and electrical equipment application.

#### NOMINAL DESIGN CONSIDERATIONS

Contact capacity.....1 amp 30 volt resistive  
Contact arrangement.....SPST (NC) or SPDT  
Operating power.....As low as 1/2 watt  
Time delays.....Up to 5 seconds  
Operate on current differential as small as .05 amps  
Operate on voltage differential as small as .3 volts

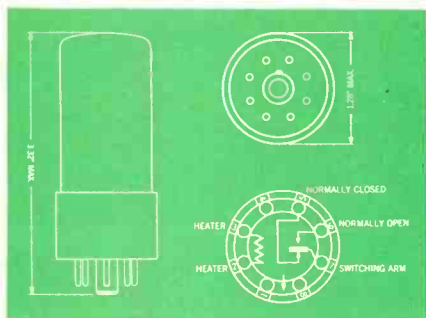

#### NOMINAL CHARACTERISTICS OF 609

Operating voltage.....6.4 volts  
Operating time.....1. plus or minus .5 seconds  
Release time.....1. plus or minus .5 seconds  
Contact capacity.....1 amp at 30 volts  
Contact arrangement.....SPDT

For additional data write:

Electroswitch Division, Tung-Sol Electric Inc., Newark 4, N. J.

Sales Offices: Atlanta, Ga.; Columbus, Ohio; Culver City, Calif.; Dallas, Tex.; Denver, Colo.; Detroit, Mich.; Irvington, N. J.; Melrose Park, Ill.; Newark, N. J.; Philadelphia, Pa.; Seattle, Wash. Canada: Montreal, P. Q.

**TUNG-SOL** THERMAL RELAYS

Table I—Values of *K* For Plate Angle

Angle of flow in degrees	Multiplying factor <i>K</i>
90	6.10
100	5.50
110	5.00
120	4.60
130	4.25
140	4.00
150	3.75
160	3.50
170	3.32
180	3.14

ditions whenever grounded-filament conditions are calculated by any of the standard methods.

The following typical constant-current characteristic curves, together with the associated grounded-filament operating data, were selected from a tube handbook as an example.

The tube used is a type 5868 as r-f power amplifier or oscillator in class-C telegraphy. Typical operation in grounded-filament circuits is shown below. The values shown are for continuous commercial service (CCS).

frequency	100 mc
d-c plate voltage	4,000 v
d-c grid voltage	-350 v
peak r-f grid voltage	580 v
d-c plate current	535 ma
d-c grid current (approx)	115 ma
driving power	60 w
power input	2,140 w
power output (approx)	1,690 w
plate dissipation	450 w

The following steps are used to determine the grounded-grid operating conditions from the above data:

- (1.) Construct the load line *AB* on the constant current curve. Locate point *A* from operating conditions. Locate *B* from operating conditions.
- (2.) Determine the total r-f plate voltage swing (*a'A*).
- (3.) Determine the total r-f grid voltage swing (*a'B*).
- (4.) Calculate the power output for grounded-grid operation.

$$\text{Power output} = \frac{a'A + a'B}{a'A} \times$$

- (5.) Determine the drive power for grounded-grid operation.  
Drive power = drive power grounded-



# "FIGURE OF MERIT"

## MEASUREMENTS

Q-METER  
Type 260-A

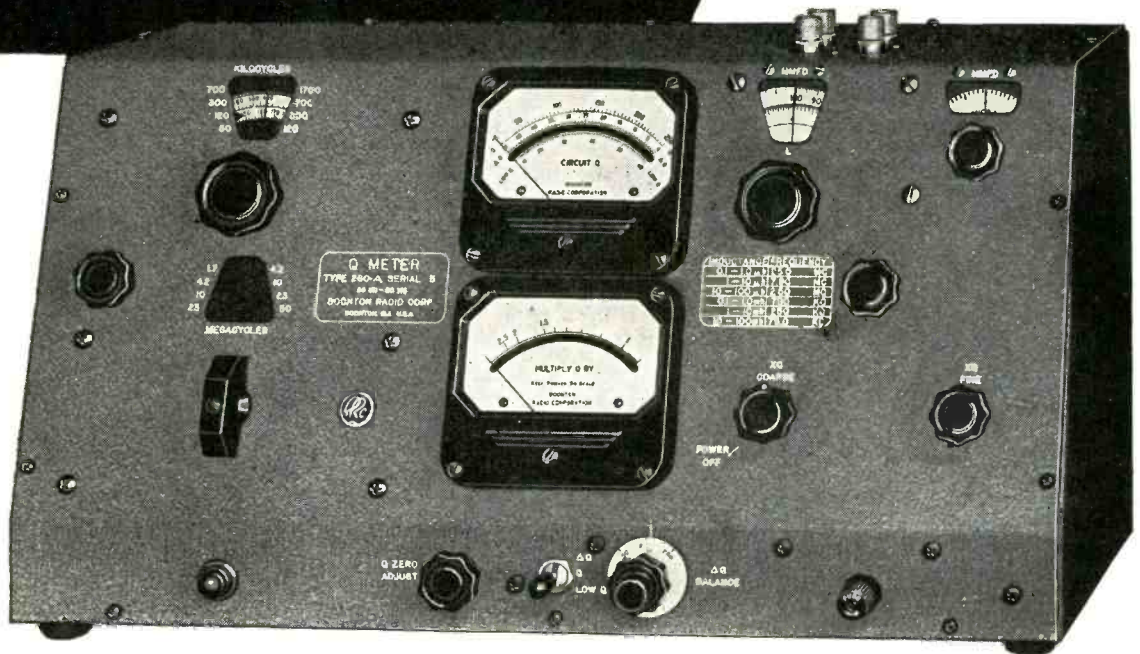

Use this versatile Q-METER TYPE 260-A for determining the "FIGURE OF MERIT" (Q) of inductors, capacitors, the selectivity and gain of a resonant circuit, and other circuit parameters associated with Q.

### DIELECTRIC PROPERTIES

Measure dissipation factor and dielectric constant of various insulating materials easily, efficiently, and with good accuracy.

#### FEATURES

LO Q SCALE: permits Q readings down to a value of 10.

$\Delta$  Q SCALE: reads the difference in Q of two circuits or components up to a value of 125.

All indications on large meters with parallax correction and accuracy of  $\pm 1\%$  full scale.

Thermocouple for indicating current inserted into measuring circuit redesigned for high burnout point well above operating current. Oscillator maximum output level adjusted to minimize possibility of thermocouple failure.

#### SPECIFICATIONS

FREQUENCY RANGE: 50 Kc to 50 Mc continuously variable in eight ranges.

FREQUENCY ACCURACY: Approx.  $\pm 1\%$ .

RANGE OF Q MEASUREMENTS: 10 to 625

RANGE OF DIFFERENCE Q MEASUREMENTS: 0 to 125.

INTERNAL RESONATING CAPACITANCE RANGE:

MAIN TUNING DIAL: 30 to 450 mmf. (direct reading) calibrated in 1.0 mmf. increments from 30 to 100 mmf; 5.0 mmf. increments from 100 to 450 mmf.  
VERNIER:  $-3.0$  to  $+3.0$  mmf. (direct reading) calibrated to 0.1 mmf. increments.

ACCURACY OF RESONATING CAPACITOR:

MAIN TUNING DIAL: Approximately  $\pm 1\%$  or 1.0 mmf, whichever is the greater.  
VERNIER:  $\pm 0.1$  mmf.

PRICE: \$775.00 F. O. B. Factory

**BOONTON  
RADIO  
CORPORATION**

Boonton, New Jersey



**0 CPS to 1 MC!**  
**DIRECT READING**



**new**  
Computer-Measurements Model 226A

**UNIVERSAL COUNTER-TIMER**

**OUTSTANDING FEATURES:**

- ★ Three independent, adjustable trigger level controls permitting full rated sensitivity at any voltage level between -300 and +300 volts.
- ★ Small voltage increments ordinarily masked by attenuators are easily selected.
- ★ Simplified color-coded controls and direct read-out in kc, mc, sec, or millisec, with automatic decimal point indication.
- ★ Oscilloscope marker signals facilitate start and stop trigger level adjustment for time interval measurement of complex waveforms.

A brand new, multi-purpose instrument provides precision measurement of frequency, frequency ratio, period (1/frequency) and time interval. Pressure, velocity, acceleration displacement, flow, RPS, RPM, etc., may also be measured with suitable transducers. The 226A may be used as a secondary frequency standard.

price: **\$1,100.00**

- Long Term: 3 parts per million per week
- Display Time: Automatic: Continuously variable 0.1 to 10 seconds
- Manual: Until reset
- Input Impedance: 1 megohm and 50 mmf
- Trigger Level: Continuously adjustable from -300 to +300 volts
- Accuracy: ± 1 count ± stability
- Secondary Frequency Standard: 1 mc; 100, 10, 1 kc; 100, 10, and 1 cps
- Dimensions: 17" W x 8¾" H x 13½" D approx.
- Weight: 50 lbs. approx.

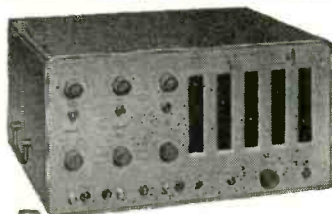

**MODEL 225A** 0 cps-100 kc  
**UNIVERSAL COUNTER-TIMER**

Similar to the 226A in design. Featuring Oscilloscope Trigger Level Marker Signals; Three Direct-Coupled Inputs of 70 mv sensitivity; Direct Reading, Automatic Illuminated Decimal Point. Easily portable. Price: **\$840.00**

Data Subject to Change Without Notice - Prices F.O.B. Factory  
Write for complete specifications on the new 226A and the 225A models and the complete CMC line of electronic counting and controlling equipment.

**Computer-Measurements Corporation**

5528 Vineland Avenue, North Hollywood, Calif. 78H

**SPECIFICATIONS:**

**FREQUENCY MEASUREMENT**

Frequency Range: 0-1,000,000 cycles per second  
Input Sensitivity: 0.2 volt rms. Direct-coupled input  
Time Bases: 0.00001, 0.0001, 0.001, 0.01, 0.1, 1 and 10 seconds. Also can use external 0-1 mc standard

**PERIOD MEASUREMENT**

Period Range: 10 microseconds to 1,000,000 seconds  
Frequency Range: 0.000001 cps to 100 kc  
Input Sensitivity: 0.2 volts rms. Direct-coupled input

Gate Times: 1 and 10 cycles of unknown frequency  
Standard Frequency Counted: 1 mc; 100, 10, 1 kc; 100, 10, 1 cps; external 0-1 mc.

**TIME INTERVAL MEASUREMENT**

Range: 3 microseconds to 1,000,000 seconds  
Start and Stop: Two independent or common channels Positive or negative slope  
Input Sensitivity: 0.2 volts rms. Direct-coupled input  
Standard Frequency Counted: 1 mc; 100, 10, 1 kc; 100, 10, 1 cps; external 0-1 mc.

**GENERAL**

Stability: Short Term: 1 part in 1,000,000 (temperature-regulated crystal)

FREQUENCY • TIME INTERVAL • PERIOD • FREQUENCY • PERIOD • TIME INTERVAL • PERIOD • TIME INTERVAL • FREQUENCY

PERIOD • TIME INTERVAL • FREQUENCY • PERIOD • TIME INTERVAL • PERIOD • TIME INTERVAL • FREQUENCY

filament + difference between power output for grounded-grid and grounded-filament operation.

For example, refer to the typical operating conditions and constant-current curves for the type 5868/AX9902 triode.

- (1.) Locate point A ( $E_b=4,000$ ,  $E_c=-350$ ) and point B  
Peak plate current is determined by multiplying average d-c plate current by the proper factor,  $K$ . For class-C operation use a factor of 4 and for class-B and class-AB operation a factor of 3.14.  
 $i_{bmax} = I_b \times K = 0.535 \times 4 = 2.14$  a  
 $e_{cmax} = E_c + E_b = 580 - 350 = +230$  v  
point B ( $i_{bmax} = 2.14$ ,  $e_{cmax} = +230$ )
- (2.)  $a'A = 4,000 - 300 = 3,700$  volts
- (3.)  $a'B = 580$  volts
- (4.) Grounded-grid power output =

$$\frac{3,700 + 580}{3,700} \times 1,690 = 1,950 \text{ w}$$

- (5.) Grounded-grid drive power =  $60 + (1,950 - 1,690) = 320$  w

The typical operating conditions for grounded-grid are: driving power approximately 320 w, power

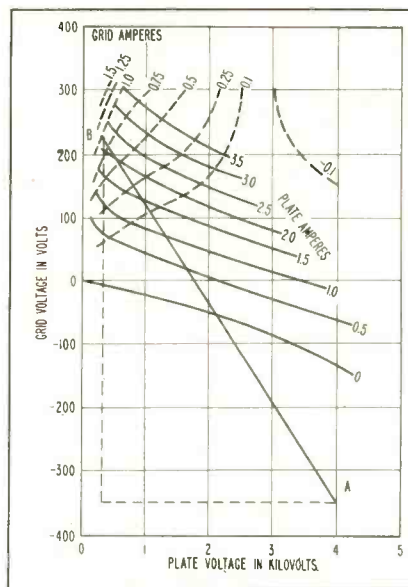

FIG. 2—Constant-current characteristics of type 5868 tube

output approximately 1,950 w.

All other conditions are the same as for grounded-filament operation.

The results are approximate since they depend on the accuracy of the grounded-filament data. They also do not provide for the greater circuit and tube losses inherent at the higher frequencies used in grounded-grid operation.

The method outlined above assumes an angle of plate current flow of 140 deg for class-C operation and 180 deg for class-B and



the complete job  
with heavy-duty  
discaps...at  
no added cost!

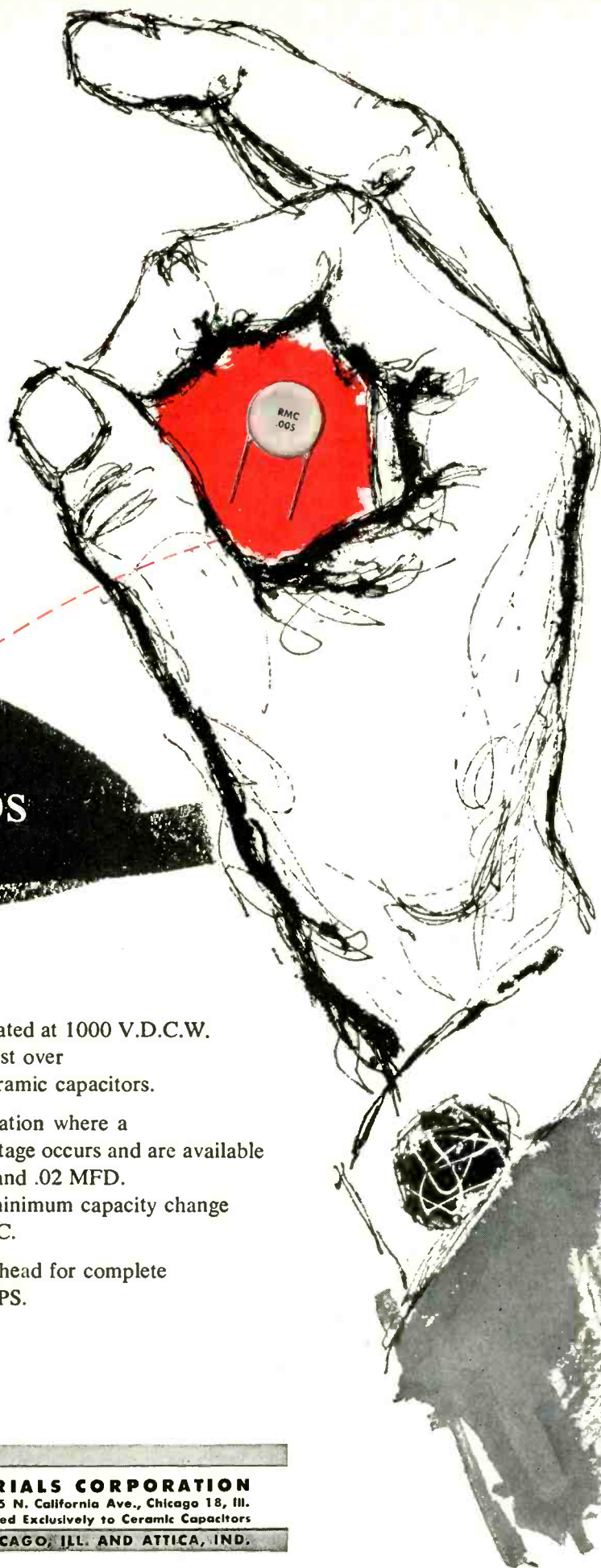

## RMC Type B Discaps

RMC Type B DISCAPS are rated at 1000 V.D.C.W. and are offered at no extra cost over lighter constructed by-pass ceramic capacitors.

They are ideal for any application where a steady or intermittent high voltage occurs and are available in capacities between .00015 and .02 MFD.

Type B DISCAPS exhibit a minimum capacity change between  $+10^{\circ}$  C and  $+65^{\circ}$  C.

Write on your company letterhead for complete information on RMC DISCAPS.

DISCAP  
CERAMIC  
CAPACITORS

**RMC**

**RADIO MATERIALS CORPORATION**

GENERAL OFFICE: 3325 N. California Ave., Chicago 18, Ill.

Two RMC Plants Devoted Exclusively to Ceramic Capacitors

FACTORIES AT CHICAGO, ILL. AND ATTICA, IND.

**always  
the leader  
— all ways**

**Engineered Economy\* Iron Cores  
originated by  
Radio Cores, Inc.**



\*trademark

★ the leader in quality

★ the leader in price

★ the leader in engineering

★ the leader in volume

★ the leader in design

Just a few short years ago, Iron Cores cost over 100% more than at the present time. This has been achieved by the creation of our line of ENGINEERED ECONOMY\* IRON CORES which enables us to reduce the amount of your minimum inventory through guaranteed immediate delivery service . . . this has been achieved by the new use of automation which enables us to cut costs and pass these savings on to you . . . this has been achieved by more efficient production methods, which reduce processing and material costs which again means savings to you.

Now, you can select from over  
19 types of ENGINEERED ECONOMY\*  
IRON CORES which do the job of over 100 types  
... custom-made cores at stock prices. We invite your inquiry.

Also, custom iron cores to your specifications.

**Radio Cores, Inc.**

9540 Tulley Avenue Oak Lawn, Illinois



Copyright 1956  
Radio Cores, Inc.

class-AB operation. For other angles of plate current flow the factor  $K$  must be adjusted as shown in the table.

### Large Shielded Enclosure

BY RICHARD J. COSTELLO and  
BRYCE D. McMICHAEL  
General Laboratories Dept.  
Bell Aircraft Corp.  
Buffalo, N. Y.

A LARGE shielded room, 40 ft long by 35 feet wide by 18 ft high, has been designed to accommodate complete aircraft and missile systems. The system is isolated within the area and sufficient electrical and hydraulic power is available to operate that system, thus checking operation for electrical noise interference.

The single-walled room is constructed of galvanized iron panels bolted to steel channels and tensioners making up the supporting framework. The room closely approximates a standard copper shielded enclosure in design except for the materials used. The inside wall is covered with a painted wall-board.

► Access — Two personnel doors are located, one in each end and one large sliding door is set in a 40-ft wall section. This equipment door clears 16½ ft high by 21 ft wide and is supported on a track and column arrangement completely external to the room itself. The doors open in two sections. They are motor operated and air-bladder-sealed when closed.

Copper and brass have been used on all door closures to insure effective electrical contacts. The room is air-conditioned to maintain uniform temperatures during all testing operations.

Twenty-six power line entrances are provided for the enclosure, each line being filtered by Tobe-Deutsch-

Table I — Attenuation of Large Shielded Enclosure

Frequency	Attenuation in db	Type Filed
150 kc	71	Magnetic
200 kc	106+	Electric
1.0 mc	106+	Electric
18.0 mc	104	Electric
400 mc	84	Plane Wave



To **engineers** who want to straighten  
out the curves in their careers...



**DOUGLAS TEAMWORK  
HELPS TO RELIEVE  
ENGINEERS OF  
BURDENSOME  
PROJECT DETAILS!**

There are no "dead end" jobs at Douglas. As part of a crack engineering team, you'll be encouraged to use your full talents. Important assignments will give you the opportunity for greater accomplishments and the kind of future you want for you and your family. Wherever you choose to locate — in California or across the nation — Douglas offers many career opportunities including...

**TOP ASSIGNMENTS FOR THERMODYNAMICISTS!**

Mechanical Engineers work on all phases of analysis, design and installation of equipment involved in heating, cooling and air distribution at high speeds.

For important career opportunities in your field, write:

C. C. LaVENE  
DOUGLAS AIRCRAFT COMPANY, BOX F-620  
SANTA MONICA, CALIFORNIA

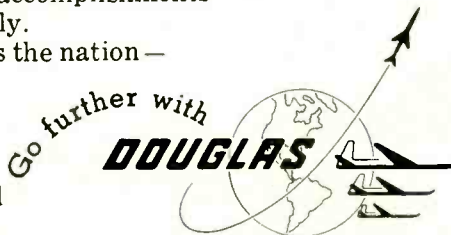

**FIRST IN AVIATION**

# here's another ENGINE GENERATOR SET designed and built by HOMELITE

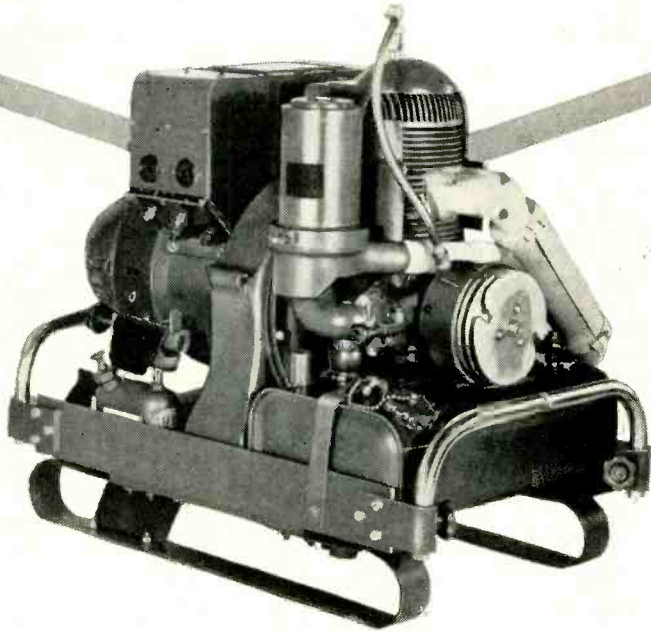

This lightweight, gasoline-engine-driven generator is another example of how Homelite met and solved a particular power supply problem. Designed and built to the most exacting MIL specifications, this generator has a military rating of 3 KW\*, 120/208 volt, 400 cycle, single and 3 phase AC at 0.8 P.F. and has been supplied fully winterized for starting and operation at temperatures down to  $-65^{\circ}\text{F}$ .

If you have a need for light, compact, gasoline-engine or electric-motor-driven generators that must meet stringent MIL specifications, call Homelite first. With over 30 years' experience in designing and building hundreds of thousands of generator sets from .15 KW to 5 KW in a variety of voltages and frequencies, Homelite will be first with the best solution to your power supply problems.



\*This military rating must be met at 5000 ft., after 500 hours of operation, and at an ambient temperature of  $107^{\circ}\text{F}$ . Under average conditions this unit is capable of producing close to 5 KW.

For the full story, write for Homelite's new booklet, "Generators for Military Use."

**HOMELITE**  
A DIVISION OF TEXTRON INC.  
6808 RIVERDALE AVENUE, PORT CHESTER, NEW YORK  
MANUFACTURERS OF CARRYABLE PUMPS  
GENERATORS · BLOWERS · CHAIN SAWS

Canadian Distributors: Terry Machinery Co., Ltd.



Looking through the large equipment door into the shielded room

man line filters 1650-1 and 1753. These filters were chosen because of their rated attenuation of 100 db over the frequency range from 14 kc to 15,000 mc. With these filters, the total power capacity of the room is 300 amperes at 28-v d-c and 35 kva of either 60 or 400-cycle a-c. Five hydraulic oil entrances are provided through the wall of the room to enable servo system operation of an aircraft or missile during the test.

Ace Engineering & Machine Co. designed the room and Bell Aircraft personnel together with Electro-Search, Inc. and International Electronics Engineering, Inc., conducted tests. The first test was conducted on a similarly constructed room of much smaller dimensions.

A second test was then performed upon the large room in accordance with the military specification. The results of this test are presented in Table I.

At the higher test frequencies (400 mc) no adequate and satisfactory explanation of the different results obtained for the large (84 db) and small (110 db) rooms could be found. A definite signal leakage through the large room existed, but there was no single major source for this leakage.

Owing to the 2,500 linear feet of seams in the room, there might be sufficient leakage per foot to account for the discrepancy. Ambient temperature could affect results by varying leakage and resistance of the joints between panel seams. It was noted that results varied from day to day and from season to season.

Oxidation of door-contact surfaces, or air-bladder pressure extremes might also affect leakage.



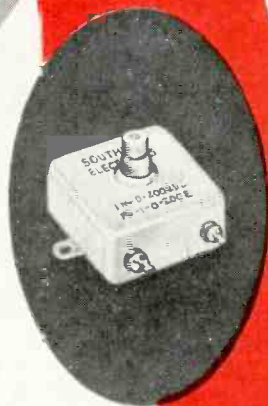
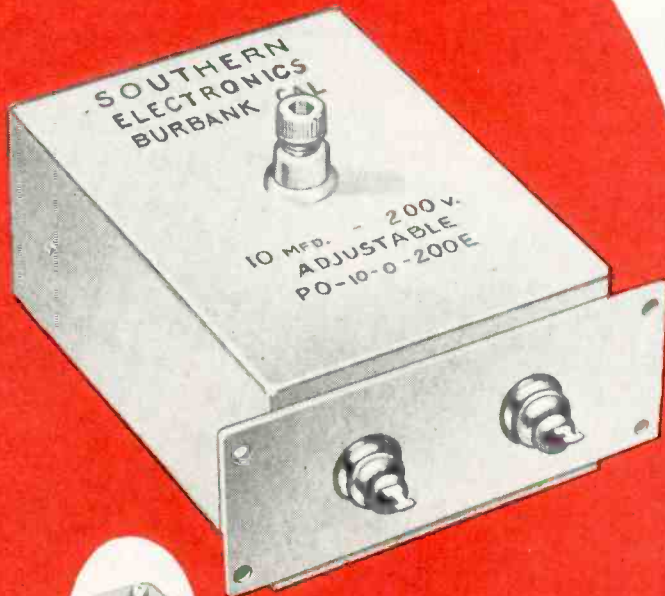

**NOW AVAILABLE FROM  
0.1 M.F.D. to 10 M.F.D.**

Check these outstanding features:

- Accuracy in the order of 0.1% or better!
- Long Time stability in the order of 0.03%!
- I.R. — @ 25° C —  $10^{12}$  OHMS
- Dielectric Absorption — .015%
- Dissipation Factor — .0002
- Temp. Coeff. (—20° to 140° F.) 100 P.P.M. per °C

Excellent for Computer Integration, Test Equipment or Secondary Standards.

America's electronic leaders specify Southern Electronics' polystyrene capacitors for their most exacting requirements. Goodyear Aircraft, Beckman Instruments, Reeves Instrument Corp., Electronic Associates, Inc., Convair, M.I.T., Calif. Inst. of Tech., and many others. Make sure you're getting the finest — always specify S.E.C.!

Wire, write or phone for complete catalog today!

**ADJUSTABLE**  
precision  
polystyrene  
capacitors

... WITH PERFECT  
HERMETIC SEAL TO  
INSURE EXTREMELY  
LOW LEAKAGE!

REG. U.S. PAT. OFFICE



**SOUTHERN ELECTRONICS**  
*Corporation*

150 West Cypress Ave., Burbank, California



## Juke-Box Transistor Tester Lights Up Sorting Glasses

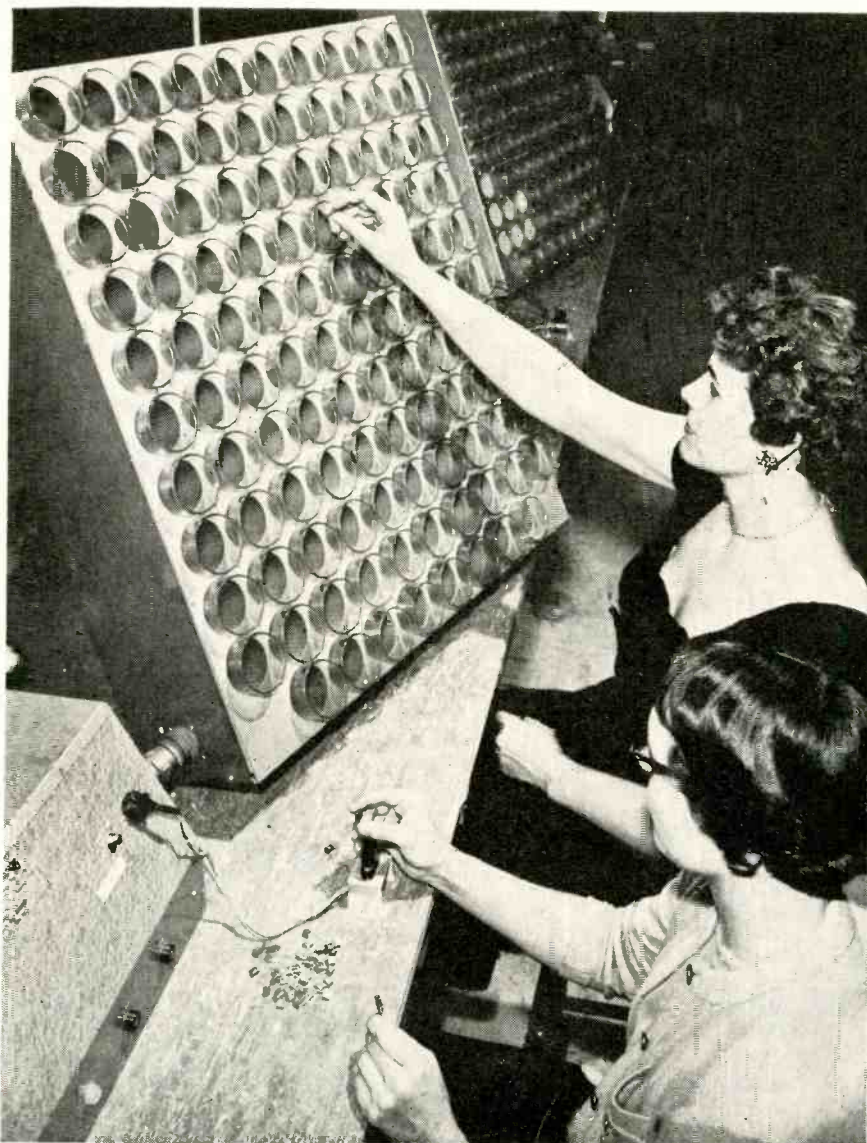

Juke-box tester for matching germanium audio transistors for use in push-pull class B operation. After checking five parameters, tester lights pilot lamp under correct plastic glass in frame, to guide operator at rear who does actual sorting

TRANSISTORS for matched audio applications are automatically given five different tests in less than one second, after which the correct sorting bin for that particular transistor is indicated by a pilot lamp, in the Dallas plant of Texas Instruments Incorporated. This permits accurate sorting into 108 different categories, for precision matching. Two of these bins are for units which do not qualify as audio devices but are still useful as small-signal general-purpose transistors.

Plastic 8-ounce drinking glasses serve here as sorting bins. A clear 6-watt, 115-volt pilot lamp behind each glass creates an edge-lighting effect at the rim, to indicate clearly to the operator the correct sorting receptacle for that transistor.

Time studies showed that two operators more than doubled the number of transistors which could be measured and sorted by one operator. One loads the transistors into the test socket and removes them. The other, seated directly in front of the sorting frame, picks up the tested transistor and places it in the illuminated glass. All transistors in a given glass are perfectly matched in beta value, for use in class B push-pull operation.

The characteristics checked are collector cutoff current with base and emitter grounded, punch-through characteristics between collector and emitter, 100-ma beta check, 50-ma beta test and 5-ma beta test.

## Wrapping of Leads Cuts Quality of Soldered Joints at Terminals

WRAPPING OF LEADS around terminals prior to soldering is now an obsolete manufacturing procedure, according to J. Roy Smith of U. S. Navy Electronics Laboratory in San Diego. Those solder-soaked knotted joints are unnecessary and make parts replacement extremely difficult. Simple soldered connections are adequate and more reliable for all environments provided large parts and wiring harnesses

are clamped down to prevent the relative motion which fatigues wires and causes failure.



Bends of about 120 deg. as shown here, are now considered adequate

► **Recommended Joints**—In chassis wiring, when using stud terminals the recommended procedure is to

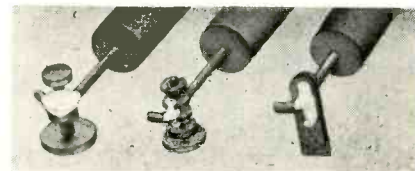

Unwrapped joints give better visibility for inspection of soldering



"DAD, WHAT'S  
'OLD PRO'  
MEAN?"

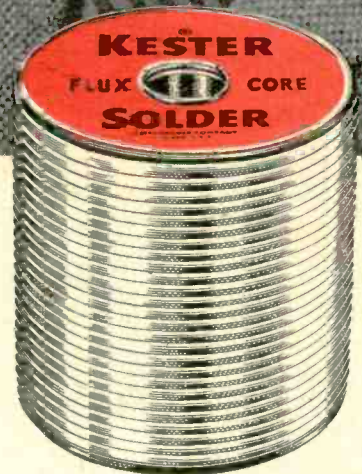

## KESTER FLUX-CORE SOLDER

Leave it to a child to get to the heart of the matter quickly. No gobbledygook or double-talk is going to turn him aside from his single-minded objective.

It's like that with solder. No meager test dependent upon a "sample" or even a "one-line operational test" is going to prove conclusively the merits of a "Johnny-come-lately" solder from

that second source of supply. The wise buyer knows that the solder used on his production line must do the job he requires day-in and day-out without question.

And KESTER SOLDER has been time-tested and industry-proved for over 50 years.

That's what we mean by "old pro," Sonny!

**SEND TODAY** for your copy of the 78-page Kester textbook, "Solder ... Its Fundamentals and Usage." It's free!

**KESTER SOLDER** *Company* 4204 Wrightwood Avenue, Chicago 39, Illinois  
Newark 5, New Jersey • Brantford, Canada

## Design of the Month: NOISE TUBE

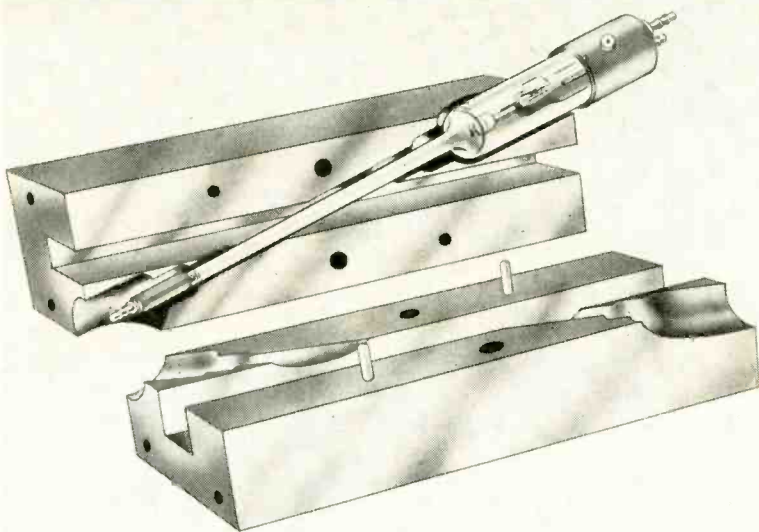
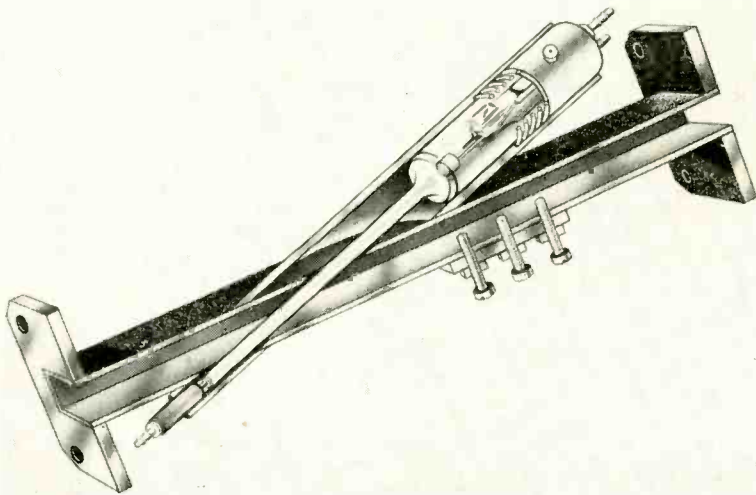
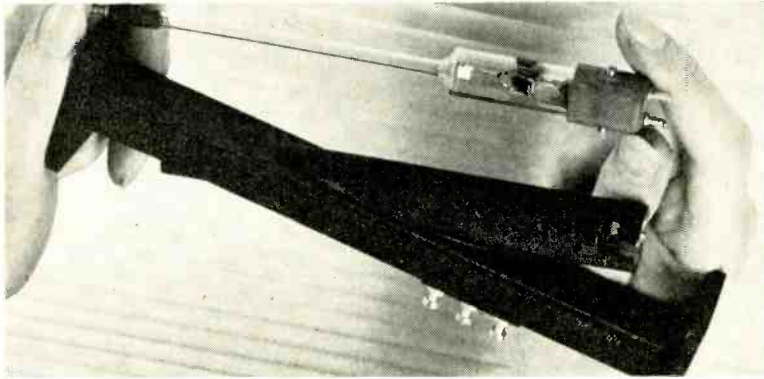

Waveguide mount only  $7\frac{1}{4}$  inches long holds Ferranti TE10 X-band noise tube at 15-deg angle. Three screws enable user to tune from 8,500 mc to 10,500 mc, for generating constant noise output of 15.25 db for testing noise factor of microwave superheterodyne receivers. Alternative milled-block construction uses mated channels. Division down center lines of major dimension does not affect electrical performance yet simplifies construction, allows internal inspection of waveguide and facilitates inspection of components. Construction time is about one-third of that required to make conventional waveguide assembly. Distributed by Ferranti Electric Inc., 30 Rockefeller Plaza, New York City

bend pigtails around the terminals a little more than a right angle (say 120 degrees).

For slotted terminals the pig-tails are placed in the slots and the ends of the leads bent aside to lock the part in place.

For eyelet terminals the pigtails are placed in the holes and the ends of the leads also are bent aside to prevent the part from falling out. These are hand operations without pliers. The surplus ends of the pig-tails should be cut off with hand cutters, leaving about  $\frac{1}{8}$  inch extension on the leads after the bend. This extension holds the part in place until soldered.

► **Harness Joints** — Connecting wires and cables in completed equipment must be clamped down at intervals to prevent fatigue under environmental motion. Cable harnesses should be clamped down before soldering. If this is done the same joints can be used as for hookup wires. However, the lead extensions should be bent in the direction of the tendency of the wire to move, to hold the wire in place until soldered.

► **Inspection**—Absence of the old multi-wrap technique before soldering leaves the terminal clear for a much closer inspection. The quality of the soldered connection is readily determined by inspection. If it can be seen that the solder has wetted the surface of both the terminal and the wire lead and that solder has flowed tangentially to form a concave fillet between the two parts, then a continuous soldered connection is assured.

► **Repair**—Replacement of parts is greatly simplified by these pro-

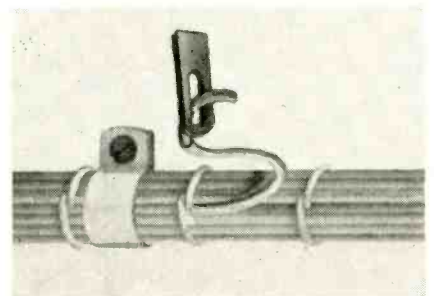

Cable lead should be bent in direction shown here, just enough so it cannot fall out before soldering



from **PSI**...

*these silicon products:*

*high conductance diodes*

*general purpose diodes*

*fast recovery diodes*

*miniature rectifiers*



*8 typical diodes in  
PSI's high conductance series*

	Peak Re- current Inverse Voltage (volts)	Maximum Forward Voltage @ 25°C (volts)		Maximum Inverse Current ( $\mu$ a)			Maximum Average Forward current (ma)	
		@ 100ma	@ 200ma	@ 25°C	@ 150°C	Test Voltage	@ 25°C	@ 150°C
PS 606	80	1.1		.250	30	- 70	125	50
PS 611	80		1.0	.025	5	- 70	200	100
PS 618	200	1.1		.250	30	- 180	125	50
PS 623	200		1.0	.025	5	- 180	200	100
PS 630	330	1.1		.250	50	- 300	125	50
PS 633	330		1.0	.100	25	- 300	200	100
PS 634	420	1.1		.250	50	- 380	125	50
PS 637	420		1.0	.100	25	- 380	200	100

PSI offers a complete line of high-reliability silicon products for a broad range of applications.

The High Conductance series includes 38 types consisting of useful combinations of d.c. inverse voltages, forward conductance, and inverse leakage limits. Most requirements can be filled by one of these types.

WRITE TODAY for new specifications describing PSI's complete line of semiconductor products.

*pacific  
semiconductors,  
inc.* 

10451 West Jefferson Boulevard, Culver City, California

# HIGH POWER at TRANSISTOR VOLTAGES

## Model DV 60-2 Transistor POWER SUPPLY

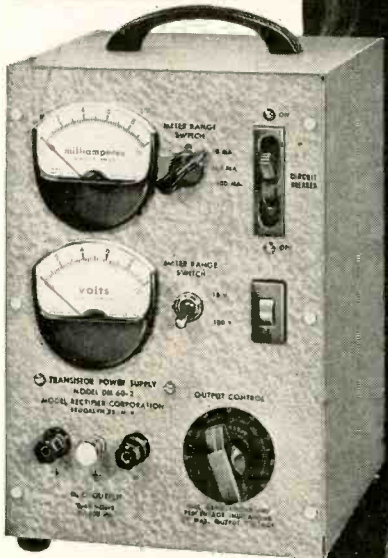

**\$110**

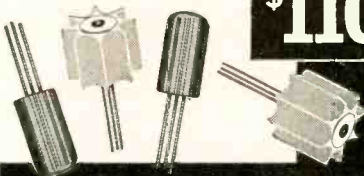

Thorough and versatile! Efficiently powers all transistor circuits. Unparalleled performance and price.

- AC OPERATED, delivers 0-60 volts DC at currents up to 1000 milliamperes.

- SUPERIOR to conventional DC power supplies specified for vacuum tube high voltage range and offering erratic reactions when used at low transistor voltages.

- CONTINUOUSLY VARIABLE, equivalent to a battery. High power.

- RIPPLE SUPPRESSION below .05% at rated current, by two section choke input filter.

- COMPLETE CONTROLS, front panel switch-type magnetic circuit breaker, neon pilot light, Powerstat output control, multirange voltmeter and milliammeter and output binding posts. Meters accurate to 2%, readable at distance. Height 10 3/4", Width 7", Depth 9 1/4", 21 lbs.



WRITE FOR CATALOG OF ENTIRE LINE  
**MODEL RECTIFIER CORPORATION**  
 1065 Utica Ave.  
 Brooklyn, New York

Circle 142 Readers Service Card

cedures. Damaging forces formerly applied to terminals and tube sockets when removing wrapped joints during parts replacement are eliminated. The lead extension may be merely untwisted from a stud terminal without heating the joint excessively.

## Conductive Wax Makes Battery Connections

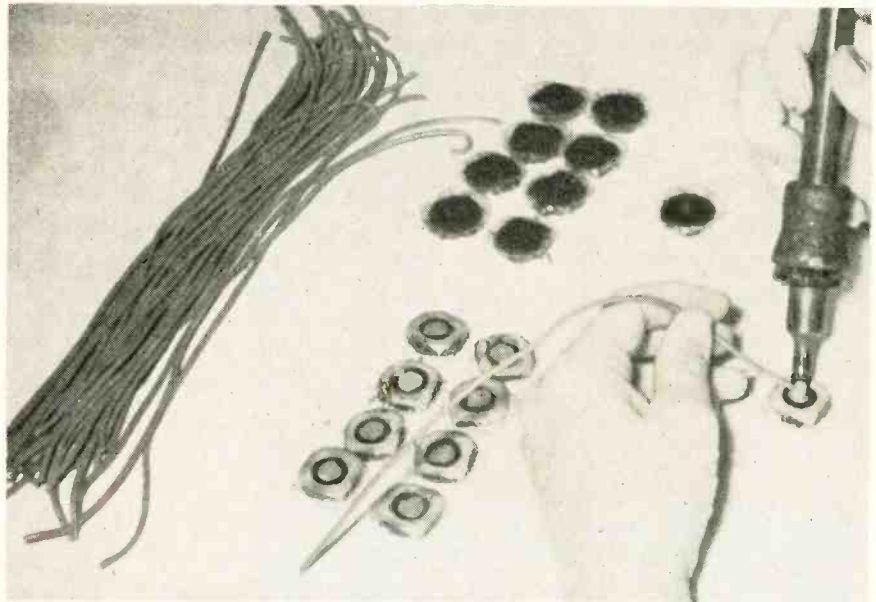

Using low-temperature pencil-type soldering iron to apply wax to zinc side of wafer cell. The wax is similarly applied to graphite side, as on cells shown at rear

SERIES CONNECTIONS between individual wafer-type cells of dry batteries are made automatically by stacking, after a new Burgess conductive wax is applied to the sides of the cells. The wax adheres to a wide variety of materials, including zinc, aluminum, magnesium, graphite and copper, making possible many other types of electrical connections as well. The new wax is available from Burgess Battery Company, Freeport, Ill.

Heating to about 170 F converts the wax to its liquid form, for easy application. At room temperature the material becomes a solid. It consists of a high-quality wax and a finely divided metallic powder such as silver, mixed in a critical ratio. If the wax content is too high, the particles of metal tend to become islands and resistance goes up. If the wax content is too low, the material loses its fluidity at high temperatures. A typical resistance value for the material is 0.005 ohm-cm, but this can be varied within rather wide limits.

► **Applying Wax**—Although the wax can be readily heated in a glass beaker and poured, many other methods are possible. One method involves extruding the material at room temperature into strings about 0.1 inch in diameter, much like ordinary solder. In this form the wax can easily be applied to the desired surface by hand, using a low-temperature soldering iron for melting the wax.

In mechanized production, the wax can be melted and applied by a printing setup. Alternatively, a small amount of solid conductive wax can be placed between the two surfaces to be joined, and the objects then heated until the wax melts and bonds to the surface. Since the cold wax is conductive, an electric current can be sent through the wax to produce the necessary heat.

► **Conductive Tape**—Work is now in progress on the production of a conductive wax tape. With this, two conductors can be connected by



# SRU-55 Series Klystrons give high power at low voltage

Small reflex oscillator klystrons for 14.5-17.0 kmc and 15.7-17.0 kmc

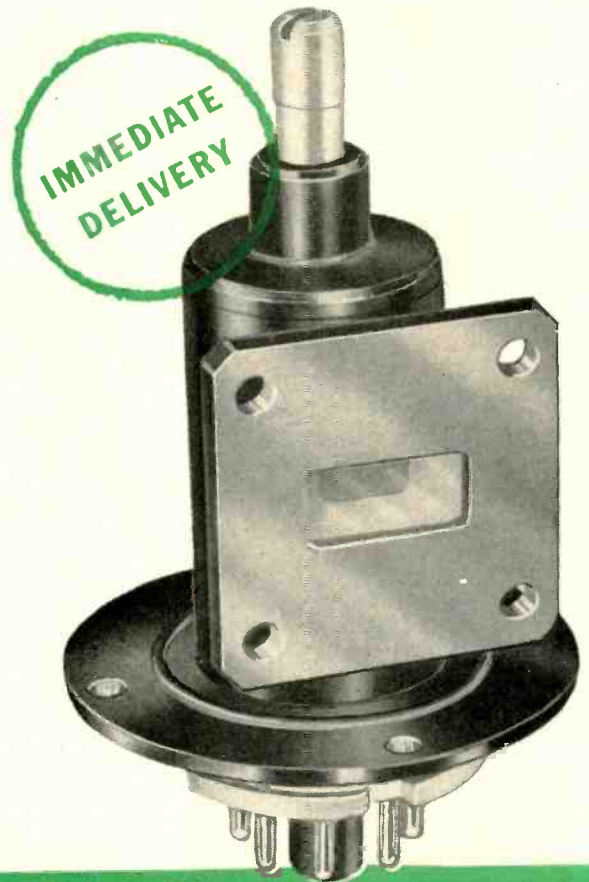

## SRU-55 OPERATING SPECIFICATIONS

14.5 to 17.0 kmc  
300 v  
45 to 75 mw  
20 mw

## SRU-55A OPERATING SPECIFICATIONS

Frequency	15.7 to 17.0 kmc
Beam Voltage	300 v
Output Power (optimum load)	40 to 45 mw
Minimum Output Power	20 mw

Ready for immediate delivery are two Sperry K Band Klystrons. The SRU-55 and SRU-55A satisfy a multiplicity of requirements yet are manufactured with the economies of a single tube type.

The SRU-55 was developed primarily as a local oscillator in radar systems.

Only 3 $\frac{1}{2}$ " high and 1 $\frac{1}{16}$ " in diameter, it couples rugged construction with superior vibration characteristics to withstand the severe environment of airborne applications for thousands of hours. The SRU-55 exhibits high

frequency stability under abrupt changes in line voltage. Objectionable leakage has been controlled to eliminate need for external shielding. Other features include low voltage operation and ease of tuning over an extremely broad range with no appreciable hysteresis.

The SRU-55A was designed especially as a signal source for test sets like the AN/UPM-28-29. Other applications: local oscillator in microwave receivers and spectrum analyzers; low-power transmitting tube. Important features

include minimum leakage and excellent test modes. Dimensions and operating features are similar to those of SRU-55. Write or phone your nearest Sperry district office for more details.

**SPERRY** ELECTRONIC TUBE DIVISION  
**GYROSCOPE COMPANY**  
Great Neck, New York

DIVISION OF SPERRY RAND CORPORATION

BROOKLYN • CLEVELAND • NEW ORLEANS • LOS ANGELES •  
SAN FRANCISCO • SEATTLE. IN CANADA: SPERRY GYROSCOPE  
COMPANY OF CANADA, LTD., MONTREAL, QUEBEC

Visit our booths 2309-2310 at the Wescon Show.

let Williams  
help you apply

**FERRIC  
OXIDES**

to the manufacture  
of your

**FERRITES**

You'll be well repaid by getting the facts on a special group of Pure Ferric Oxides, developed by Williams especially for use in the manufacture of ferrites.

Williams Ferric Oxides analyze better than 99%  $Fe_2O_3$ . They contain a minimum of impurities. They are available in a broad range of particle sizes and shapes. Among them, we're certain you'll find one that's "just right" for your requirements. The proper application of Ferric Oxides to the manufacture of Ferrites is our specialty.

Tell us your requirements . . . we'll gladly send samples for test. Chances are good that our Ferric Oxide "Know How" can save you considerable time and money. Address Dept. 25, C. K. Williams & Co., Easton, Pa.

**WILLIAMS**

**COLORS & PIGMENTS**

**C. K. WILLIAMS & CO.**

Easton, Pa. • East St. Louis, Ill.  
Emeryville, Cal.

**P.S.** We also produce IRN Magnetic Iron powders for the Electronic Core Industry, the Magnetic Tape Recording Industry and others. Write for complete technical information.

Circle 144 Readers Service Card

PRODUCTION TECHNIQUES

(continued)

simply taping them together. It is also possible to incorporate the silver powder in adhesives or glues which can be used to join conductors mechanically as well as electrically.

## Magnetic Rings Hold Tiny Tube Parts

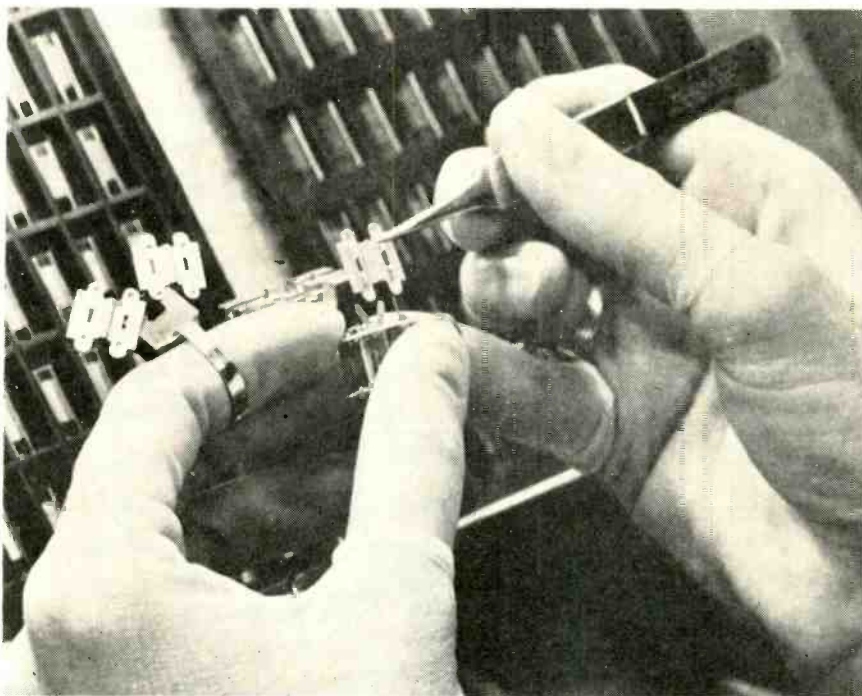

Method of using permanent-magnet ring to hold tiny parts during assembly of electrode structure for high-reliability tubes. Operator now picks up all parts before starting

A SMALL PERMANENT MAGNET worn as a ring simplifies the assembly of tiny parts for electronic tubes in the Owensboro, Kentucky plant of General Electric Co. Motion studies indicated that use of the U-shaped Alnico 5 magnets stepped

up this tweezer-type assembly operation 12 percent. Formerly, time was lost in making the extra motions needed to pick up the tiny parts individually from their bins as they were needed during the assembly.

## Turntable Speeds Assembly of Panels

A SIMPLE PLYWOOD turntable having felt-padded wood and metal fixtures for holding seven large power supply panels upright at one time contributes to production efficiency on short runs of special equipment in the Clifton, N. J. plant of Federal Telephone and Radio Co., a Division of IT&T. The operator installs components in convenient groups on each panel in turn without changing her working position. As an example, the two meters are mounted as a group, since they call for the same screwdriver and socket wrench.

A grooved wood strip positions each panel radially. An adjustable

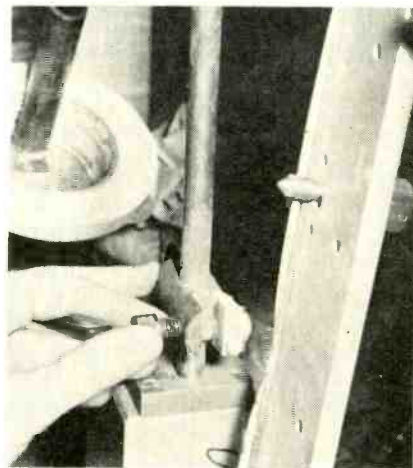

Simple clamp with knurled lock screw holds each panel upright during assembly



# SHORT LENGTH- SMALL NECK DIAMETER- MINIATURE BASING-



Off-center neck design for sector-scanning applications.

## SAVE **SPACE** AND **WEIGHT** IN AIRBORNE RADAR

Miniaturized 3" to 12" diameter radar tubes save space and weight in military and commercial installations. Ideal for use in airborne radar or *any* installation requiring high performance with miniaturization. Du Mont miniaturized radar tubes feature short overall length and small neck diameter. Nine-pin miniature design saves base and socket weight. Reasonable power requirements aid in reduction of associated circuitry size and weight.

Detailed specifications upon request . . .

### DU MONT RADAR TUBES

TABLE OF IMPORTANT SPECIFICATIONS								
Type	Diameter	Length	Focus	Deflection	Neck Diameter	Voltage	Deflection Angle	Screen
B1173	3"	5 $\frac{1}{8}$ "	Elect.	Mag.	$\frac{7}{8}$ "	7KV	70°	Alum.
K1517	3"	6 $\frac{3}{8}$ "	Elect.	Mag.	$\frac{7}{8}$ "	8KV	Off Center Neck	Alum.
5BCP-	5"	7"	Mag.	Mag.	$\frac{7}{8}$ "	8KV	70°	Reg.
B1174	5"	6 $\frac{3}{8}$ "	Elect.	Mag.	$\frac{7}{8}$ "	8KV	70°	Alum.
B1142	7"	8 $\frac{1}{2}$ "	Mag.	Mag.	$\frac{7}{8}$ "	8KV	70°	Reg.
B1175	7"	7 $\frac{13}{16}$ "	Elect.	Mag.	$\frac{7}{8}$ "	10KV	70°	Alum.
B1191	10"	10 $\frac{3}{16}$ "	Elect.	Mag.	$\frac{7}{8}$ "	10KV	70°	Alum.
B1132	10"	12 $\frac{1}{2}$ "	Elect.	Mag.	1 $\frac{1}{16}$ "	10KV	78°	Reg.

Industrial Tube Sales, Allen B. Du Mont Laboratories, Inc., 2 Main Ave., Passaic, N. J., U.S.A.



**EXTREMELY COMPACT!**  
**NEW Beattie**  
**OSCILLOTRON**  
 Camera  
 Recording System  
 Model K-5



**K-5 Oscillotron with Camera and 35mm Magazine**

Based on a group of interchangeable components, the Beattie Oscillotron Model K-5 Recorder provides with one basic component, a foundation for a complete recording system from Single Frame to Continuous Motion, plus Polaroid-Land.

**OUTSTANDING FEATURES**

- Extremely compact – body extends only approx. 6 in. Especially desirable for rack mounted oscilloscope and radar scope displays
- Fast, easy interchangeability from one camera to another
- Instantly changeable film magazines (35mm, 70mm, or Polaroid Land).
- No special tools required for attaching or removing unit
- Oscilloscope controls remain unobstructed
- Mounts directly to standard 5.6" Oscilloscope bezels

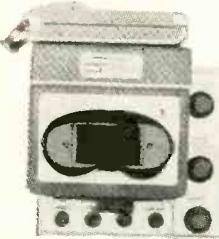

**K-5 Oscillotron with Polaroid Land Camera**

- Oscilloscope display may be viewed with both eyes while recording
- Complete remote automatic operation
- One periscope for all types of recording.

Write today for complete detailed specifications and prices.

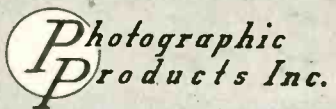

1000 NORTH OLIVE STREET, ANAHEIM CALIF.

Circle 146 Readers Service Card

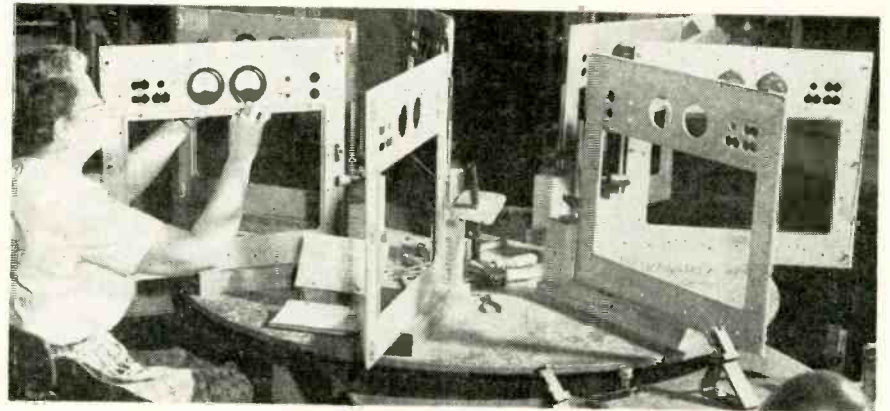

Method of using turntable to expedite installation of parts on seven power supply panels at a time. Holding clamps are padded with masking tape to protect finished front surface of panel

clamp on a vertical rod provides vertical support for each panel, permitting use of the table for a wide range of panel heights in standard rack width.

The turntable is readily turned by hand as required to move the next work position in front of the operator. Flip-up cards indicate parts to be installed.

**Solder Wave in Pot Replaces Dip Soldering**

SOLDERING TIME and temperature are reduced to a minimum in a new dip-soldering machine which lifts the molten solder up to the board

in the form of a linear wave. Only a 2-inch-wide strip of the board is in contact with the molten solder at any given time, so that warping

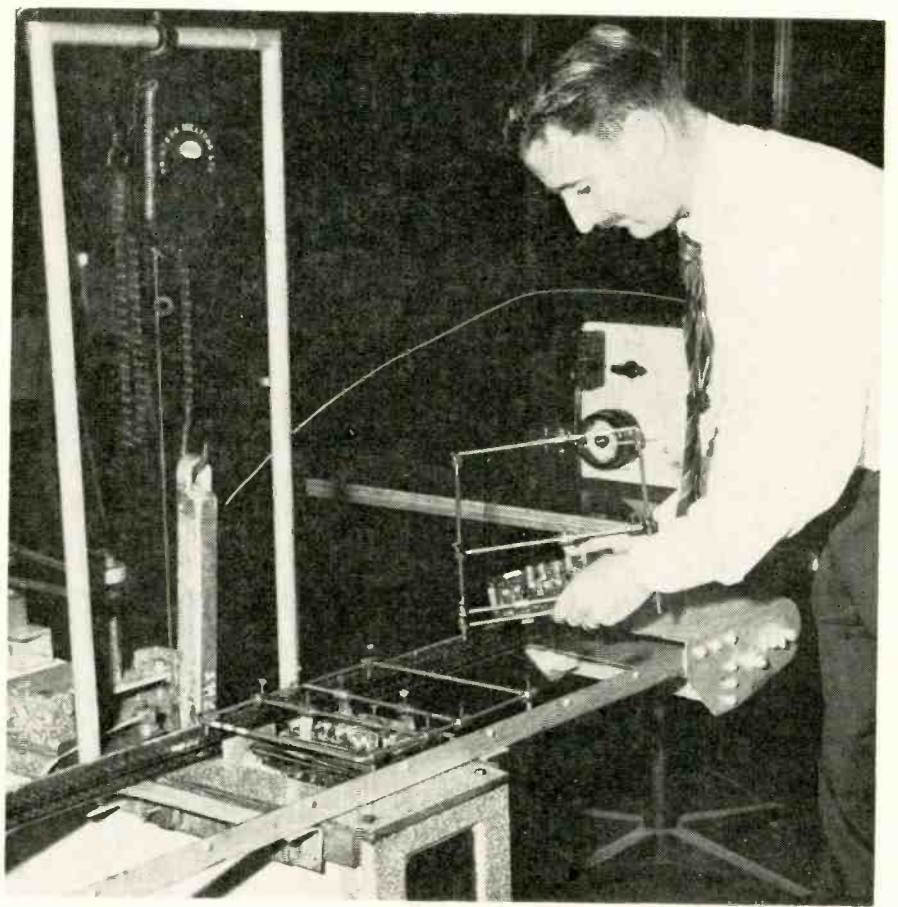

Demonstration of new soldering machine, in which simple motor-driven bicycle-chain conveyor is used to move board-holding pallets smoothly across top of solder wave



Having your  
ups  
and downs?



... if they involve Wire Wound Resistors

# DALOHM has the answer!

All Dalohm products are carefully designed and skillfully made to assure you of supreme quality and dependability, plus the widest versatility of application.

Outstanding examples of the Dalohm line are these miniature, silicone-sealed, wire wound resistors.

You Can Depend On



FOR THOSE TIGHT SPECIFICATIONS

## TYPE PH

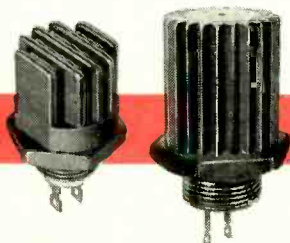

These Dalohm resistors combine high power rating with sub-miniature design. High heat dissipation and protective covering are achieved with vertical-finned black anodized aluminum housings. Vertical single hole panel mounting is provided by integral threaded base and lock nut. Ruggedized construction assures dependability under the most extreme conditions.

- Completely welded construction from terminal to terminal
- Silicone sealed for absolute protection against moisture, shock and salt spray
- Three wattages and sizes: PH-25, 25 watts; PH-50, 50 watts; PH-100, 100 watts
- Resistance values from 0.1 ohm to 60K ohms, depending on type
- Tolerances from 0.05% to 3%

Ask for Bulletin R-33

## TYPE RH

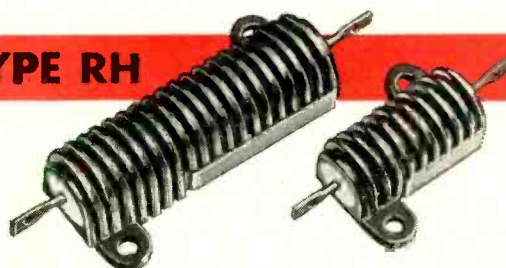

Another Dalohm resistor that resolves power and space problems in tight specifications. Black anodized finned housing provides protection and maximum heat dissipation. Mounting lugs provided for horizontal mounting.

- Completely welded construction from terminal to terminal
- Silicone sealed for absolute protection against moisture, shock and salt spray
- Three wattages and sizes: RH-25, 25 watts; RH-50, 50 watts; RH-250, 250 watts
- Resistance values from 0.1 ohm to 100K ohms, depending on type
- Tolerances from 0.05% to 3%

Ask for Bulletin R-21C

**JUST  
ASK  
US**

You are invited to write for the complete catalog of Dalohm precision resistors, potentiometers and collet-fitting knobs.

If none of our standard line fills your need, our staff of able engineers and skilled craftsmen, equipped with the most modern equipment, is ready to help solve your problem in the realm of development, engineering, design and production.

Just outline your specific situation.

**DALE PRODUCTS, Inc.**

1300 28th Avenue Columbus, Nebraska, U.S.A.

• Export Dept: Pan-Mar Corp.  
1270 Broadway  
New York 1, N. Y.



# P&B PROGRESS

A REVOLUTIONARY, NEW HIGH SHOCK/VIBRATION RELAY\*

NOW!

A latch relay that withstands 100<sub>g</sub> shock and 30<sub>g</sub> vibration to 2000 cps.

\*KG RELAY (Pat. Pending)

ONLY 2.0 WATTS AT NOMINAL VOLTAGE FOR 12 MILLISECONDS EFFECTS ARMATURE TRANSFER



NEW  
POTTER & BRUMFIELD  
KG SERIES RELAY

The new KG magnetic latch relay was designed by P&B engineers at the insistence of leading aircraft and missile manufacturers and their suppliers of control systems. A permanent magnet which locks the armature into position is the secret of the KG's dramatically high resistance to shock and vibration.

In addition to withstanding 30<sub>g</sub> vibration from 6 to 2000 cps, tests show the contacts will open for no more than 80 microseconds during 100<sub>g</sub> shock.

Armature transfer from one set of the 6PDT contacts to another can be made in approximately 12 milliseconds with only 2.0 watts at nominal voltage. The KG is rated for ambient temperatures from -65°C to +125°C.

The KG, together with other relays in the P&B "Star Series", has vastly increased the realm of relay reliability for critical applications demanding positive action of all components. Write or wire today for complete technical data.

POTTER & BRUMFIELD, INC., PRINCETON, INDIANA—SUBSIDIARY OF AMERICAN MACHINE & FOUNDRY COMPANY



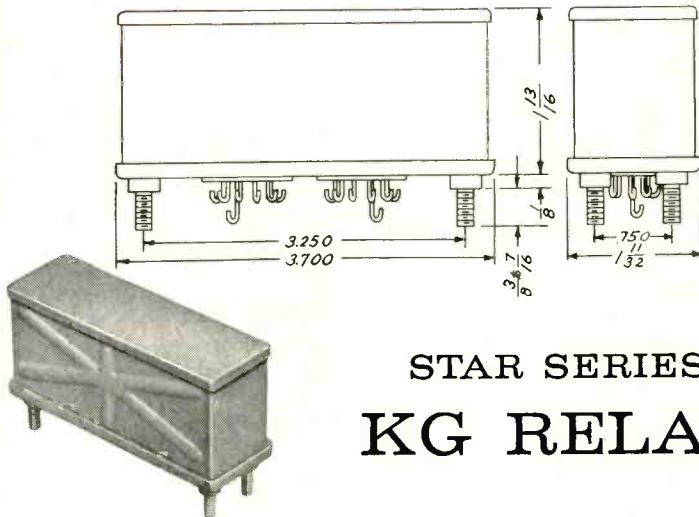

## STAR SERIES KG RELAY

**DESIGNATION:** KG23DBH

**GENERAL: Insulating Materials:** Teflon, glass and ceramic.

**Insulation Resistance:** 100 megohms min.

**Breakdown Voltage:** 500 V. RMS.

**Shock:** 100g where contact openings less than 80 microseconds may be permitted.

**Vibration:** 30g 5 to 2000 cycles.

**Ambient Temperature:** -65°C to +125°C.

**Weight:** 13 ozs.

**Pull-in-Speed:** 12 MS using 310 ohm coil at 24 V. DC. (25°C).

**Terminals:** Two 11 pin multiple solder headers with hook ends for 3 #20/AWG wires.

**Enclosures:** Hermetically sealed only.

**Dimensions:** 1-11/32 x 3.700 x 1-13/16 (See drawing for width, etc.)

**CONTACTS: Arrangements:** 6 pole double throw.

**Load:** Dry circuit to 3 amps, 115 V. AC, resistive. 5 amps, 28 V. DC, resistive.

**COIL: Power:** 2.0 watts at Nominal Voltage.

**Duty:** Either coil may be left energized without damage to the relay.

**Insulation:** Teflon tape.

**MOUNTINGS:** Four 3/8 inch #8-32 studs on 3/4 x 3/4 inch centers.

**COIL DATA:(EACH COIL)**

<b>Voltage:</b>	6 V. DC	12 V. DC	24 V. DC	48 V. DC	110 V. DC
<b>Resistance:</b>	14 ohms	55 ohms	310 ohms	835 ohms	5500 ohms
<b>±10% @ 25°C</b>					

See What's New in P&B Progress at Booth 603, 604 WESCON, San Francisco, August 20-23

# Potter & Brumfield, inc.

PRINCETON, INDIANA

Subsidiary of AMERICAN MACHINE & FOUNDRY COMPANY Manufacturing Divisions  
also in Franklin, Ky. and Laconia, N. H.

Mail the coupon below for further engineering data on P&B's new Star Series relays plus new compact catalog of standard type relays. If you need answers to a specific application problem, write in detail.

Potter & Brumfield, Inc., Princeton, Indiana  
Attn: T. B. White, Brig. Gen. M.C. (Ret.)  
Special Projects Engineer

Please send me complete data on the new Star Series relays, plus the new compact catalog of P&B standard relays.

Name \_\_\_\_\_  
Company \_\_\_\_\_  
Address \_\_\_\_\_  
City \_\_\_\_\_ Zone \_\_\_\_\_ State \_\_\_\_\_

and heat damage to components are minimized. The new machine was developed by Fry's Metal Foundries Ltd. of London, England and is being made available here by Electrovert Inc., 489 Fifth Avenue, New York, N. Y.

► **How It Works**—The solder pot holds approximately 500 lb of solder, held at 480F by thermostatic control of electrical heating units. The solder wave is produced by forcing molten solder through a U-shaped horn having a circular inlet in which is mounted a motor-driven impeller pump. The output end of the horn is an 8-inch long

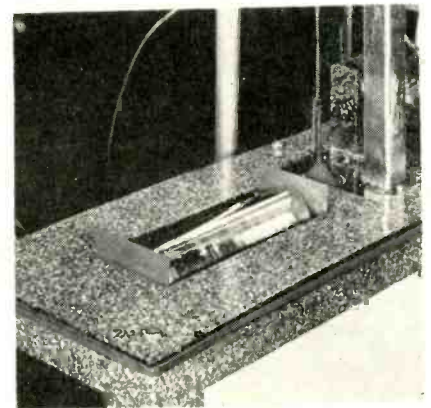

Closeup view of solder wave formed by pumping molten solder up through rectangular opening

rectangle projecting about 3/4 inch above the surface of the solder. With the impeller blade rotating in the circular input load which is well below the surface of the pot, solder is forced smoothly through the horn to emerge in the form of a rounded 8-inch-long wave that is always free from oxide. The wiring board is moved through the crest of this wave of molten solder by a simple conveyor mechanism at a speed of 4 feet per minute, to give practically perfect soldering of joints on every part of the board.

Height of the solder wave is controlled by changing the speed of the impeller. The drive motor for this is mounted on a lead screw, so that the motor position can be changed by turning a crank. This changes the tension of the V-belt which couples the output shaft of the motor gear box to the vertical shaft of the impeller blade. As ten-



# NOW QUICK SERVICE ON PRINTED CIRCUIT PROTOTYPES

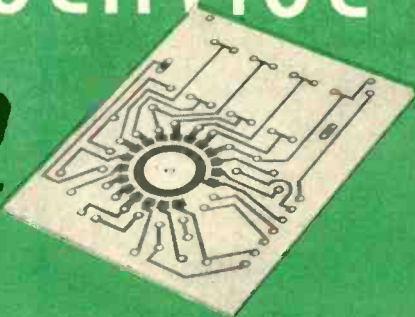

Now Photocircuits Corporation offers you  
the services of its newly formed

## PROTO DIVISION

for faster delivery of Printed Circuit Prototypes

- No need to wait weeks for a few engineering samples! We'll deliver FULLY FABRICATED parts within days from receipt of your art work or negatives and specifications.
- This separate division is completely streamlined in its methods and systems to guarantee you the fastest possible service.
- To accomplish this result a special set of "ground rules" has been formulated. Your local factory Sales-Engineer will give you all the details.
- He can figure costs *on the spot!* You will not be delayed by having to write the factory for formal quotation.

The PROTO DIVISION combines speed with the three vital attributes that have made Photocircuits the leader in the industry . . . EXPERIENCE, EQUIPMENT and CONTROL!

NOW you'll meet that deadline and still benefit from all the cost and quality advantages of printed wiring.



Phones:  
Glen Cove 4-8000  
Flushing 7-8100  
Cable: PHOCIRCO

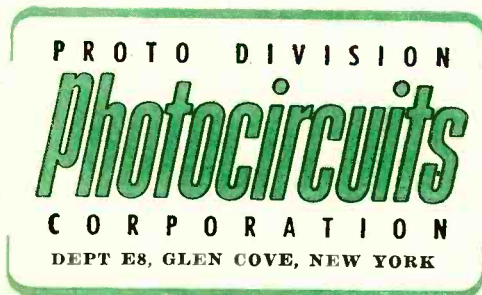

Sales- Engineering Offices:

HOUSTON, TEX. • LOS ANGELES, CAL. • AHERTON, CAL. • ROCHESTER, N. Y. • KANSAS CITY, MO.  
CHARLOTTE, N. C. • DENVER, COLO. • SPOKANE, WASH. • CHICAGO, ILL. • PHILADELPHIA, PA.

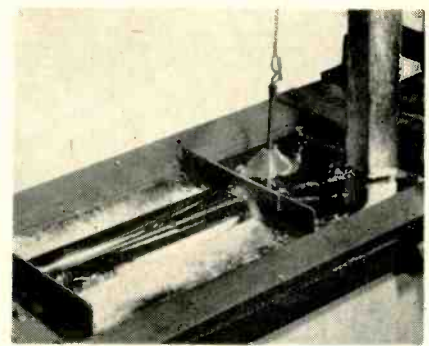

Top of machine with cover removed, showing level of molten solder in pot. At right rear is stainless steel float suspended by chain going to gear-brake arrangement controlling feed of solder ingot next to float

sion changes, a Hi-Lo automatic variable-speed spring-loaded split pulley (made by Equipment Engineering Co., 2853 Columbus Ave., Minneapolis, Minn.) on one of the shafts changes correspondingly in diameter to give the desired change in pump speed.

► **Solder**—Solder level is not critical in the pot, since the pump determines the height of the solder wave. The level is automatically maintained within  $\frac{1}{4}$  inch by a simple automatic gravity feed arrangement. A 12-lb ingot of solder 21 inches long is suspended over the pot by a bicycle chain which passes over a sprocket wheel on the large output gear of a six-gear train. On the shaft of the small input gear is a smooth drum against which a brake pad is held by spring tension. A stainless steel float in the solder pot counteracts the tension of the brake spring. When the solder level drops, the float works against the spring to release the brake, allowing the solder ingot to drop into the pot until the level is restored again.

A special Flowsolder alloy is used, with tin content slightly over the eutectic value of 63 percent and with extremely low aluminum and zinc impurity content to give high wetting properties and minimum pickup of contaminating material from the board being soldered. When this solder is applied by means of a solder wave, solder consumption is about 27 percent lower from the board being soldered.

► **Controls**—The electrical control



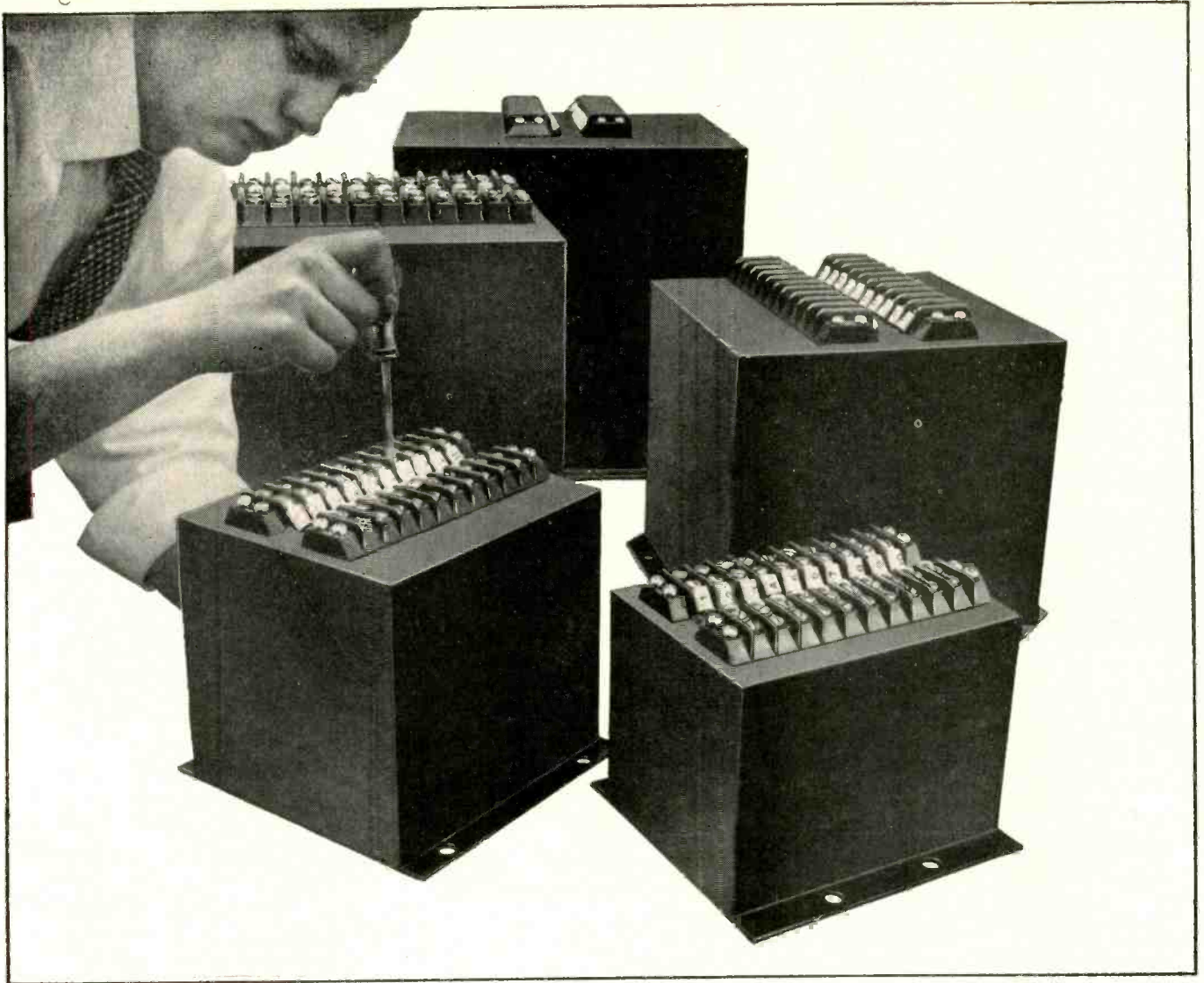

## Now--CONTROL offers you standardized saturable reactors

If you're a design engineer who would be delighted with industrial components which are sensitive and, under normal operation, last virtually forever with no maintenance or servicing, then you'll welcome CONTROL's *standard* lines of saturable reactors.

With CONTROL reactor assemblies and magnetic amplifiers, you know complete physical and operating characteristics—a copy of our Catalog R-10 awaits your request. And, delivery is fast because sub-assemblies of these units are stocked, awaiting your control-winding specifications.

CONTROL reactors are available for both 120- and 240-volt 60-cycle operation. There are eleven standard sizes in each voltage range. They have extremely high gain. Six ampere-turns control nearly 2,000 watts in the largest size. Power outputs range from 50 to 2000 watts, with only 2 ampere-turns required for control of the smallest units.

In addition to higher gain, smaller exciting current, and fewer ampere-turn characteristics, CONTROL reactors have a 40 to 1 cut-off ratio. They are totally enclosed so that the high performance toroidal cores used are protected, and the entire assembly has the ruggedness required for long life.

CONTROL offers the same convenience of standardization in use of high permeability magnetic devices that you've enjoyed with other components. Add to this convenience ruggedness and freedom from maintenance which is unmatched, and you'll welcome CONTROL to your design picture. Write for complete details and literature today. CONTROL, Dept. E-36, Butler, Pennsylvania.

Reliability begins with

**CONTROL**

A DIVISION OF MAGNETICS, INC.

# Electra... a pioneer name in precision resistors

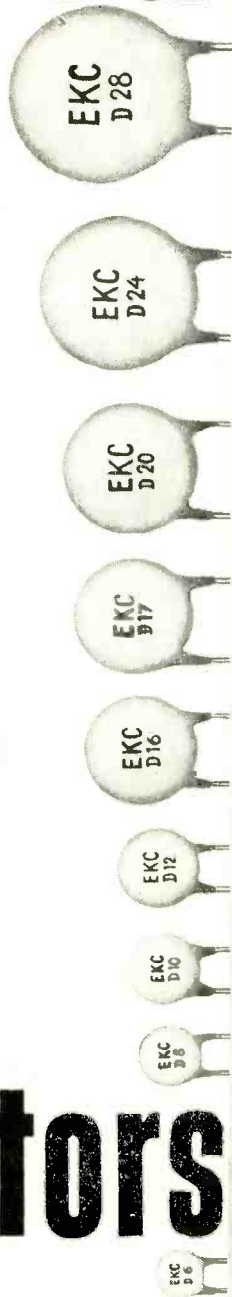

a pioneer name in precision resistors

Now...  
 America's  
 newest name  
 in  
 ceramic disc  
 Capacitors

- Temperature Compensating
- A. C. Line Filters
- General Purpose
- Extended T. C.
- General By-Pass

Electra, a pioneer and recognized leader in the precision deposited carbon resistor industry, now offers you a complete line of ceramic disc capacitors in nine physical sizes.

Electra Ceramic Disc Capacitors offer the utmost in high stability, low power factor, High Q, low drift, high insulation, and low inductance.

In Electra Capacitors you get precision, product uniformity, small physical size, a wide range of capacitance values, and low cost. Write today for full details—ask for our new Catalog Bulletin No. 101.

The above are general types available. High voltage Disc Capacitors, and other special types also available on request.



**ELECTRA MANUFACTURING COMPANY**  
 4051 Broadway — Kansas City, Missouri — WEstport 1-6864

system for the machine, made by Deselectro Co. of New York, provides four separate heating elements in the solder pot. Three of these are connected to the three phases of a 220-volt power line. The fourth is a spare which can be substituted for any of the others without shutting down the machine, merely by changing plugs. An audible alarm and pilot lamps indicate failure of a heater element and tell which one has burned out.

A 10-watt thermostat immersed in the bath is preset and sealed for the desired temperature, to prevent tampering. This controls the heating elements through contactors. A second thermostat is used to prevent starting of the impeller motor before solder is molten. A synchronous motor is used for the impeller to give constant speed regardless of voltage changes which occur as the heating elements are switched on and off by the thermostat.

► **Flux**—Special fluxes have been developed for use with the dipping unit. By adjusting the viscosity of the molten resin it has been found possible to formulate a flux which remains on the circuit panel after its passage through the solder wave while being mobile enough to allow the molten solder complete access to the printed wiring and the joints to be soldered. Because of its presence on the exit side of the solder

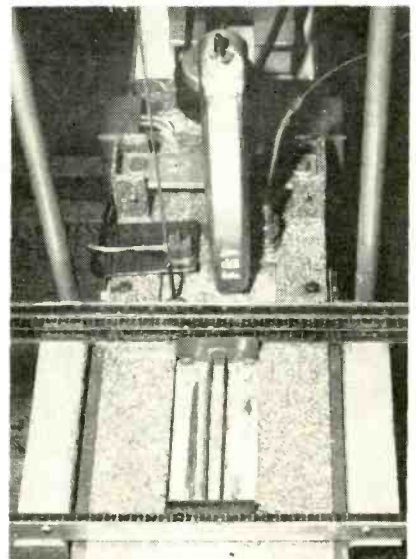

Appearance of rectangular output end of solder horn when impeller is turned off





## THE BIG STICK

Since 1946, Martin engineering has placed special emphasis on the science of rocket and missile development.

It is because of this that Martin is now building a most potent and important weapon system—the ICBM Titan—an ocean-spanning missile to back up the traditional American policy of peace with honor:

*“Speak softly and carry a big stick!”*

From this intercontinental peace protector to the world’s first satellite launching vehicle now nearing completion, Martin engineering is pioneering the new age of missiles and rockets.

If you are on the watch for tomorrow, watch Martin today.

---

**MARTIN**  
BALTIMORE · DENVER · ORLANDO

# Better solders, fluxes and alloys for better electronic components

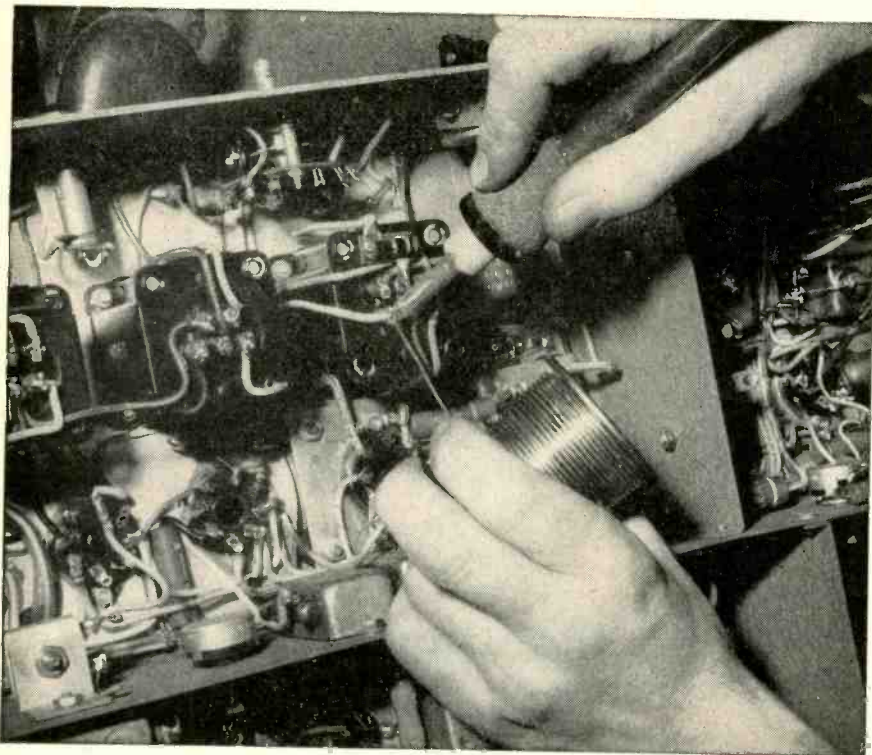

For volume production components, Federated supplies these quality-controlled alloys and non-ferrous supplies:

1. Counter-electrode alloys that are spectrographically or quantometrically tested. Samples from each heat meet exacting specifications to assure proper performance.
2. Rosin Core and Activated Rosin Core Solders of uniform quality for high-speed production, competitively tested to assure maximum efficiency and non-corrosive characteristics.
3. Liquid fluxes that surpass government corrosion-free requirements.
4. High-fluidity Castomatic® Solder for printed circuits, automatically cast under pressure in air-tight machines to minimize dross formation, gives better results in the dipping pans.

All Federated products are produced under the strictest quality-control procedures, developed by ASARCO's Central Research Laboratory, where spectrographically pure metals are refined for electronic experimentation.

No other producer of non-ferrous materials gives you such assurance of constant quality. Try Federated products. It will pay you well.

Federated Metals

Division of

**AMERICAN SMELTING AND REFINING COMPANY**

120 Broadway • New York 5, N. Y.

In Canada: Federated Metals Canada, Ltd., Toronto and Montreal

wave, it effectively prevents the formation of icicles and bridging. The dipped panel is covered with a thin layer of solid resin which is dry and hard, eliminating need for protective varnish.

Where a flux residue is undesirable, or inadmissible, another flux is available which is removed during the passage of the panel through the solder wave. To avoid excess solder pickup on the exit side, vibration of the panel during its passage through the solder wave is recommended with this flux.

► **Advantages**—The shape of the solder wave inherently provides angled entry and exit of the board. This feature, combined with the washing action of the moving solder, prevents trapping of flux or air at a joint. The solder wave does not interfere with normal capillary action; solder flows up through the holes around the leads to give a desired neat fillet on the top side of the board.

The constant flow of solder in-

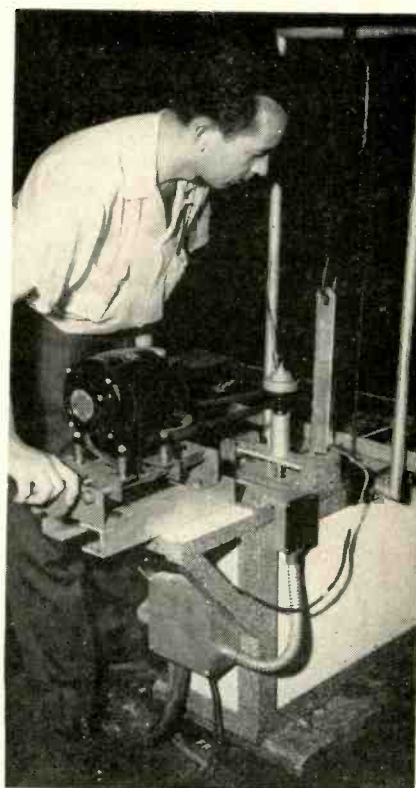

Method of changing height of solder wave. Turning crank moves motor along feed screw, changing tension of drive belt and thereby changing diameter of spring-loaded variable-speed pulley on vertical shaft of impeller running in solder bath



## GUARANTEED CHARACTERISTICS

CHARACTERISTIC	CONDITION	VALUE
"ON"	$I_B = -3\text{ma}, I_C = -2\text{ma}.$ $I_B = -2.5\text{ma}, I_C = -8\text{ma}.$	$V_{CE} = -0.07\text{V. MAX.}$ $V_{CE} = -0.10\text{V. MAX.}$
"OFF"	$V_{BE} = -0.10\text{V}$ $V_{CE} = -4.5\text{V}$	$I_C = -150\mu\text{a MAX.}$
HOLE STORAGE FACTOR	$I_E = 1\text{ma}, I_B = -1\text{ma}.$	$K_B = 120\mu\text{sec MAX.}^*$
$h_{fe}$ (5mc Current Gain)	$V_C = -3\text{V.}, I_C = -5\text{ma.},$ $f = 5\text{mc}.$	5 MIN.
$C_{ob}$ (Common Base Output Capacity)	$V_C = -3\text{V.}, I_C = -5\text{ma}.$	$6\mu\text{f. MAX.}$
$I_{CBO}$ (Collector Cutoff Current)	$V_{CB} = -5\text{V}.$	$3\mu\text{a MAX.}$

\* $K_B$  indicates total stored base charge per unit excess  $I_B$ .

### MAXIMUM RATINGS

$V_{CE} = -6\text{V}.$      $I_C = -15\text{ma}.$      $P_C = 1\text{Cmw}$   
@40°C.

### PULSE RESPONSE

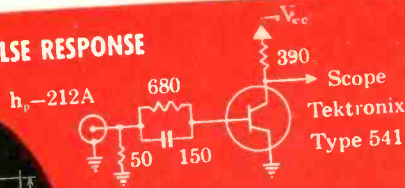
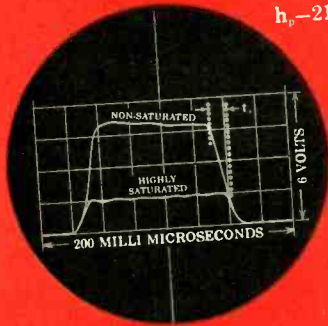

Test Conditions:  $V_{cc}$  is set to  $-6\text{V}$  and pulse input is just in saturation.  $V_{cc}$  is then lowered to  $-1.5\text{V}$  for saturated pulse curve.  $t_s$  = hole storage time.

### COLLECTOR CHARACTERISTIC IN SATURATION REGION

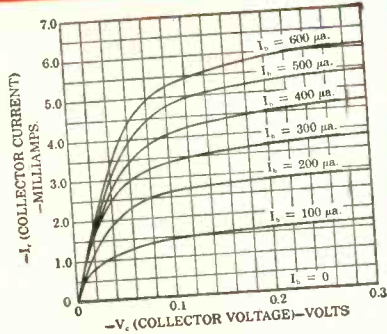

### INPUT CHARACTERISTIC

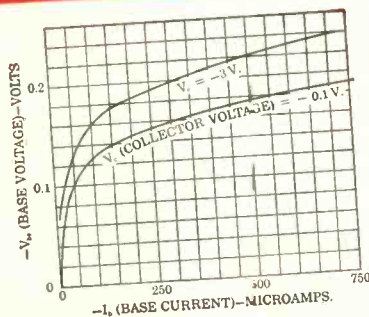

# PHILCO

## SBT\*2N240

### HIGH SPEED SWITCHING TRANSISTOR

with response time in millimicrosecond range

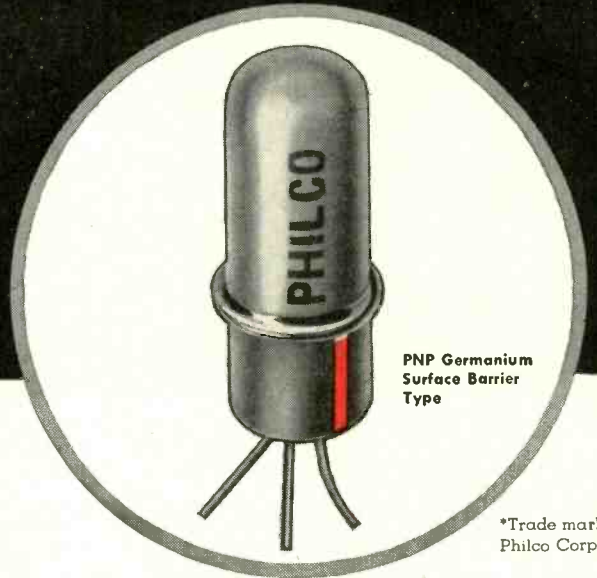

PNP Germanium Surface Barrier Type

\*Trade mark of Philco Corporation

### FEATURES

- Low saturation resistance
- Low saturation voltage
- Ideal electrical characteristics for direct coupled circuitry
- Extremely fast rise and fall time
- Absolute hermetic seal
- Available now in production quantities

All major computer manufacturers are using Philco Surface Barrier Transistors where highest reliability for both military and commercial electronic data processing is required. The Philco 2N240 has established outstanding performance and reliability records in high-speed switching circuitry... over millions of transistor hours... under a variety of environmental conditions.

*Make Philco your prime source of information for high speed computer transistor applications.*

Write to Dept. CE, Lansdale Tube Company Division, Lansdale, Pa.

# PHILCO CORPORATION

## LANSDALE TUBE COMPANY DIVISION

### LANSDALE, PENNSYLVANIA

**NEW**  
**Stupakoff**

**KOVAR-HARD GLASS**  
*hermetic seals*

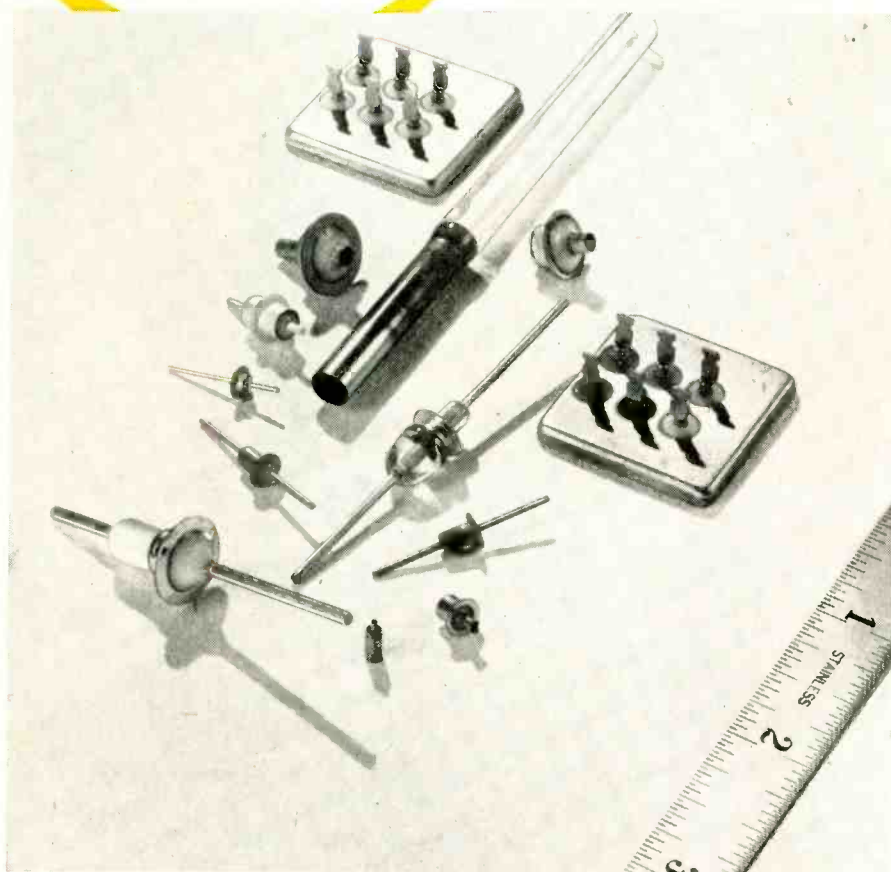

Shown above are samples of Kovar-Hard Glass hermetic seals specially made to meet specific conditions. Here is what Stupakoff—the oldest manufacturer of hermetic seals—offers users:

- Experience** . . . . . based upon years of designing and manufacturing of all types of hermetic seals. Hundreds of millions of Stupakoff Seals are in service.
- Engineering** . . . . . by thoroughly experienced engineers, familiar with the service conditions under which hermetic seals must operate.
- Manufacturing** . . . . . by modern precision production equipment, capable of making dependably uniform, top quality hermetic seals, in any quantity, large or small.

*May we send samples for your examination?*

**STUPAKOFF** DIVISION OF  
**The CARBORUNDUM Company**  
WRITE DEPT. E LATROBE, PENNSYLVANIA

sure uniform solder bath temperature regardless of the amount of heat-absorbing metal on a board. With no sudden drop in surface temperature of the solder when the board touches it, dipping time is reduced yet all joints are made at a well-defined controlled temperature. Surplus solder drains back into the pot at this same temperature, so there is no formation of icicles or bridges between adjacent conductors.

Any simple conveying system can be used to bring the prefluxed boards across the solder wave. Since the boards move along a straight path without stopping, the soldering machine is readily introduced into a completely mechanized production line. For wider boards, a 10-inch-wide nozzle can be used in the solder pot.

Since the molten solder is drawn from well below the surface, it is always clean and free from oxide or dross. Skimming of the surface is therefore unnecessary.

**Coated-Filler Resin**  
**Speeds Encapsulation**

BY R. HERR and J. S. CASEMENT  
*Electrical Products Laboratory*  
*Minnesota Mining and Manufacturing Co.*  
*St. Paul, Minnesota*

A NEW resin-applying technique eliminates the mixing operation heretofore required when encapsulating, molding or impregnating electronic components with two-part polymerizable liquid resins. Other advantages include indefinitely long pot life, elimination of the air bubble problem, boosting of

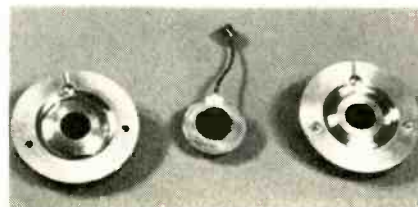

STEP 1. Coil is prepared for insertion in two-part mold

filler content, reduction of time in mold and elimination of vacuum requirements during impregnation. The new resin system developed



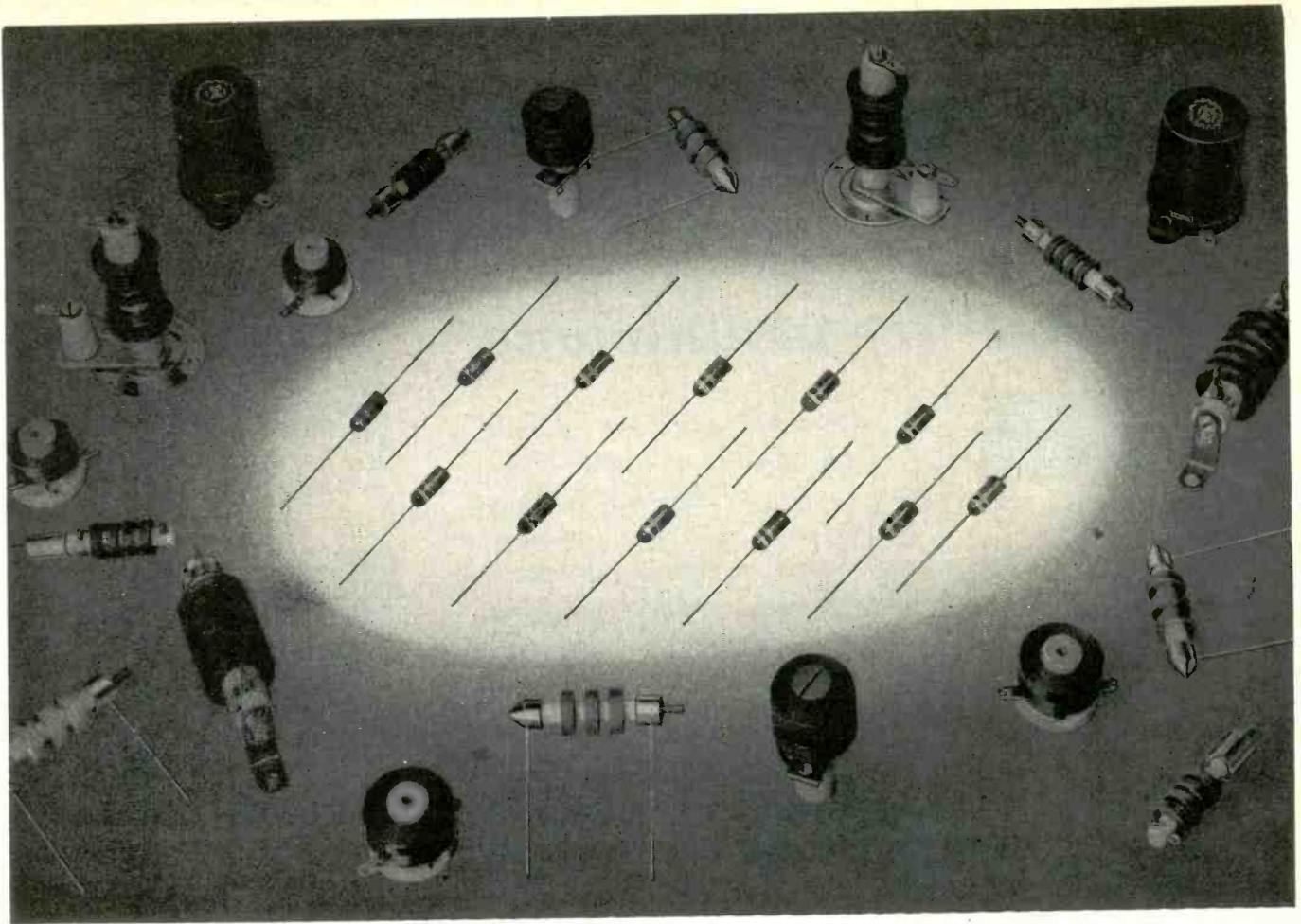

## Encapsulated Inductances

Millen DESIGNED for APPLICATION encapsulated coils provide another advance in the r-f inductor field. Modern application requires miniature, heat and cold resistant, hermetically sealed, and abrasion resistant r-f inductor assemblies. The James Millen Manufacturing Company has pioneered many advances in the r-f inductor field, including the now standard 4 pi r-f choke, the axial lead r-f choke, and the miniature r-f choke. Developments have now made possible another advance, the No. 34301 and No. J301 encapsulated inductors—hermetically sealed—miniature size. Ambient temperature minus 55 degrees to plus 100 degrees C.

### NO. J301 MINIATURE ENCAPSULATED INDUCTANCES

DESIGNED for APPLICATION miniature inductances are: extremely small (see table at right)—hermetically sealed—wound on axial lead Carbonyl cores—color coded. Coils are available in RETMA standard values plus 25, 50, 150, 250, 350, 500, and 2500 microhenries. Coils are three layer solenoids up to 350 microhenries. From 360 to 2500 microhenries coils are pi-wound. Current rating 50 to 600 milliamperes depending on coil size. Inductance  $\pm$  5%. Special coils on order.

### NO. 34301 STANDARD ENCAPSULATED INDUCTANCES

Encapsulated DESIGNED for APPLICATION axial lead phenolic form r-f inductances. Hermetically sealed—heat resistant—abrasion proof—color coded. 1 to 350 microhenries available in RETMA standard values plus 25, 50, 150, 250, and 350 microhenries. Inductance  $\pm$  5%. Values available in same progression as J301 coils listed in the table at the right. Solenoid winding for 1 to 15 microhenries. Universal pi winding from 20 microhenries to 350 microhenries. Current rating 250 to 1500 milliamperes, depending on coil size. Ambient temperature range—minus 55 degrees to plus 100 degrees Centigrade. Size:  $\frac{3}{8}$  inches diameter  $\times$   $\frac{1}{2}$  inches long. Special coils on order.

COIL NUMBER	INDUCTANCE MICROHENRIES	DIAMETER INCHES	LENGTH INCHES
J301-25	25	$\frac{3}{16}$	$\frac{9}{16}$
J301-33	33	$\frac{3}{16}$	$\frac{9}{16}$
J301-47	47	$\frac{3}{16}$	$\frac{9}{16}$
J301-50	50	$\frac{3}{16}$	$\frac{9}{16}$
J301-82	82	$\frac{3}{16}$	$\frac{9}{16}$
J301-100	100	$\frac{3}{16}$	$\frac{9}{16}$
J301-120	120	$\frac{3}{16}$	$\frac{9}{16}$
J301-150	150	$\frac{3}{16}$	$\frac{9}{16}$
J301-200	200	$\frac{3}{16}$	$\frac{9}{16}$
J301-220	220	$\frac{3}{16}$	$\frac{9}{16}$
J301-250	250	$\frac{3}{16}$	$\frac{9}{16}$
J301-300	300	$\frac{3}{16}$	$\frac{9}{16}$
J301-330	330	$\frac{3}{16}$	$\frac{9}{16}$
J301-350	350	$\frac{3}{16}$	$\frac{9}{16}$
J301-360	360	$\frac{7}{32}$	$\frac{5}{8}$
J301-390	390	$\frac{7}{32}$	$\frac{5}{8}$
J301-430	430	$\frac{7}{32}$	$\frac{5}{8}$
J301-470	470	$\frac{1}{4}$	$\frac{11}{16}$
J301-500	500	$\frac{1}{4}$	$\frac{11}{16}$
J301-510	510	$\frac{1}{4}$	$\frac{11}{16}$
J301-560	560	$\frac{1}{4}$	$\frac{11}{16}$
J301-620	620	$\frac{1}{4}$	$\frac{11}{16}$
J301-680	680	$\frac{9}{32}$	$\frac{3}{4}$
J301-750	750	$\frac{9}{32}$	$\frac{3}{4}$
J301-820	820	$\frac{9}{32}$	$\frac{3}{4}$
J301-910	910	$\frac{9}{32}$	$\frac{3}{4}$
J301-1000	1000	$\frac{9}{32}$	$\frac{3}{4}$
J301-1200	1200	$\frac{5}{16}$	$\frac{13}{16}$
J301-1300	1300	$\frac{5}{16}$	$\frac{13}{16}$
J301-1500	1500	$\frac{5}{16}$	$\frac{13}{16}$
J301-1800	1800	$\frac{5}{16}$	$\frac{13}{16}$
J301-2000	2000	$\frac{3}{8}$	$\frac{7}{8}$
J301-2200	2200	$\frac{3}{8}$	$\frac{7}{8}$
J301-2400	2400	$\frac{3}{8}$	$\frac{7}{8}$
J301-2500	2500	$\frac{3}{8}$	$\frac{7}{8}$

JAMES MILLEN



MFG. CO., INC.

MAIN OFFICE

AND FACTORY

MALDEN, MASSACHUSETTS, U. S. A.

# 1000 HOURS (OR MORE)

## of trouble-free performance

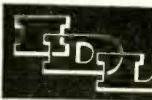
**WITH  
NEW**   
**HIGH-SPEED  
ROTARY  
SWITCHES  
FOR AIRBORNE  
APPLICATIONS**

Watchmaker's precision is combined with proved principles of electrical design to give you superior performance in high-speed multi-circuit commutation. Inherent ruggedness and strength of construction assure long, service-free life. All IDL switches are hermetically sealed. Current production assures delivery in quantity.

### TELEMETERING SWITCH

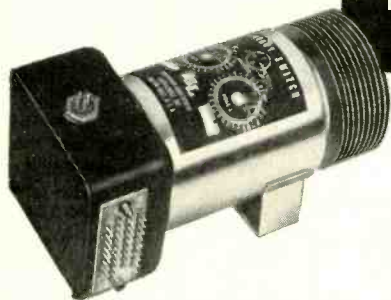

One of IDL's growing family of high-speed rotary switches for missile and aircraft applications.

3 Poles  
30 Contacts per pole, BBM  
10, 15 or 30 RPS

Power 7W or 15W      Weight 2 lbs.  
115V, 400C, single phase      Overall Length 5 1/8"

Other specifications and units for other switching applications are also available.

## Can your circuits use switching performance like this . . . ?

For 1000 or more service-free hours  
At 900 samples per second  
At -67° F to +200° F  
After being subjected to 2000 cps vibrations 12 "g"  
Under 75 g continuous acceleration  
Into loads varying from 25 ohms to megohms  
With input signals from 1 mv to 200 volts dc  
With up to 50 ma current  
With high production rates

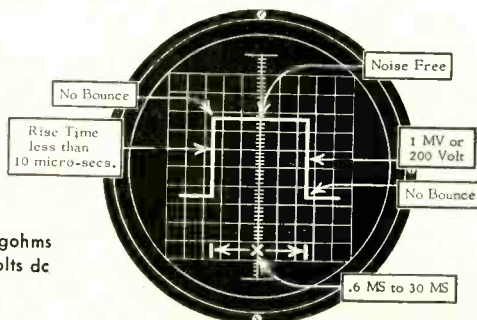

To learn more about IDL's family of switches, send us your specifications or write for our complete brochure.

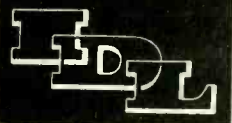

**INSTRUMENT DEVELOPMENT LABORATORIES, INC.**

An Affiliate of Royal McBee Corporation

66 Mechanic Street, Attleboro, Massachusetts, U. S. A.

In Canada: Measurement Engineering, Ltd., Arnprior, Ontario

PRODUCTION TECHNIQUES

(continued)

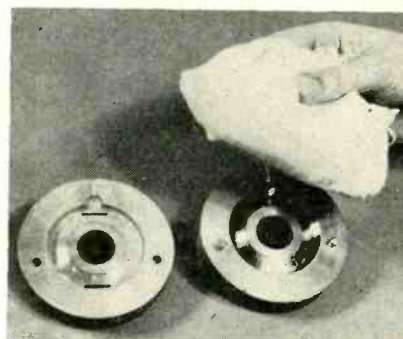

STEP 2. Applying powdered walnut shells as mold release

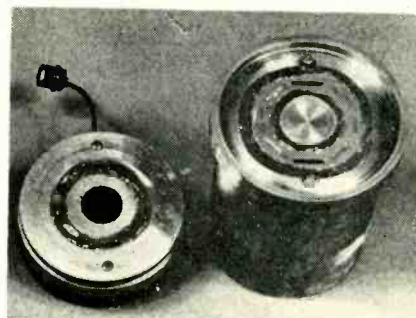

STEP 3. Coil in mold (left) and can (right) used for applying filler to mold

by 3M uses two parts, but they do not need to be mixed in the usual sense. The part used first is what is normally called the filler, consisting of inert particles. These particles are precoated with a layer of chemical which under heat or drying will bond particle to particle. The coating also is (or contains) the catalyst for the subsequent resin cure. The other component is the resin itself. This is used just as received, by allowing it to fill the interstices of the filler.

► **Example of Use**—A typical electronic application, using a low-viscosity liquid epoxy resin to form an insulating covering or tire on a television flyback coil, is currently in production at Motorola. The two parts of the mold are first dusted with a release agent such as powdered walnut shells. The coil is then enclosed in the mold and the assembly is inverted in a can having two opening slots which match those on the coil mold. The can is then filled with the bondable catalyzing filler. First a momentary blast of compressed air blows the required amount of filler into a cavity surrounding the coil. This





Do your  
transistors have  
temperature  
problems?

...solve them with

**Globar**<sup>®</sup>

thermistors



Minimize Ico variation and prevent thermal runaway by using Globar thermistors. They are available in a wide range of resistance values and temperature coefficients to meet most transistor circuit requirements.

Globar Thermistor Test Kits are available for general evaluation in transistor circuits. If you have a specific transistor temperature problem, submit details to GLOBAR Division, The CARBORUNDUM Company, Dept. E 87 - 711, Niagara Falls, New York. Ask for Technical Bulletin GR-3... describes physical and electrical characteristics of GLOBAR Thermistors.

**Globar**<sup>®</sup>

*Ceramic Resistors*

by **CARBORUNDUM**  
REGISTERED TRADE MARK

Over 30 years' experience in the field of special ceramic resistance devices

81-711 R

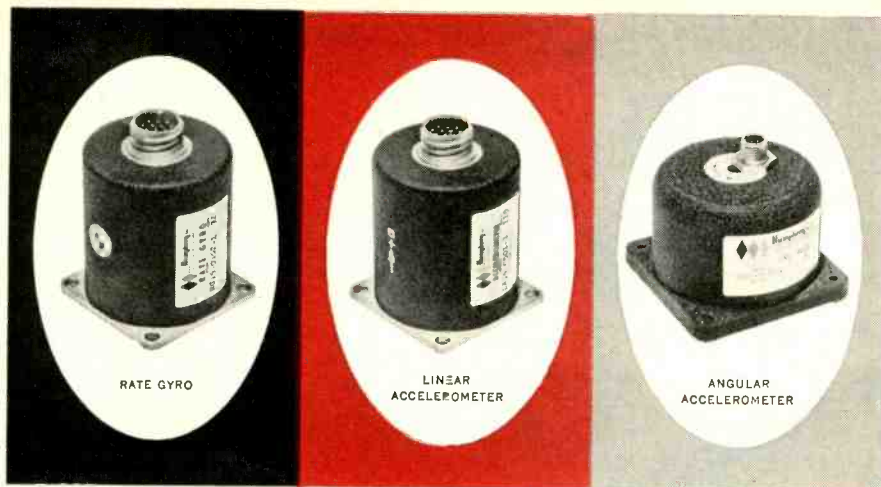

operation is a routine step in foundry practice as in the manufacture of sand cores. It is practically an instantaneous operation. Following this, hot, dry air is blown through the coil cavity for about 1 minute. This bonds the filler particles together so that the covered coil may be removed from the mold.

The next step is the introduction of the resin itself. The coil with its porous granular coating is merely set in a bath of the resin. The resin flows upward largely

## Advanced Instrumentation by Humphrey

*New production inertial sensing instruments for extra precision and reliability*

Among the outstanding features of Humphrey's new inertial sensing instruments are: dry helium filled, hermetically sealed steel cases; standardized mountings for rate gyro and linear accelerometer; and choice of regular AN connector or new pigmy connector.

**RATE GYRO** is of new simplified design, with light-weight efficient motor, accurate trouble-free damping, and choice of inductive or potentiometer pick-off.

**LINEAR ACCELEROMETER** is of dual contra-rotating mass design. It has practically zero sensitivity to cross acceleration and angular acceleration;  $\pm$  symmetrical or asymmetrical ranges (0 to 1G) to (0 to 100G).

**ANGULAR ACCELEROMETER** is compactly designed with completely symmetrical inertial ring. Available ranges are from zero to  $\pm \frac{1}{2}$  rad/sec<sup>2</sup> to zero to 100 rad/sec.<sup>2</sup> Except in very low range, either potentiometer or inductive pick-off can be furnished. Performance for either instrumentation or control systems is excellent.

FOR COMPLETE SYSTEMS, SPECIFY HUMPHREY GYROSCOPES, ACCELEROMETERS, POTENTIOMETERS



**Rate Gyro—Model RG15-0102-1:** New simplified design with light-weight efficient motor.



**Linear Accelerometer—Model LA15-0501-1:** Zero sensitivity to cross and angular acceleration.

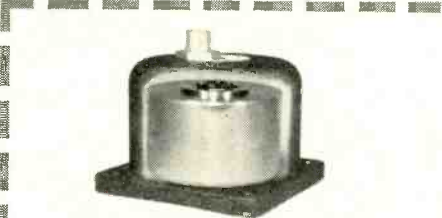

**Angular Accelerometer—Model AA01-0207-1:** Excellent performance for instrumentation or control systems.



2805 CANON ST. • SAN DIEGO 6, CALIF.

Send full information

NAME \_\_\_\_\_  
 COMPANY \_\_\_\_\_  
 ADDRESS \_\_\_\_\_  
 CITY \_\_\_\_\_ STATE \_\_\_\_\_



**STEP 4.** Can in position over mold to serve as funnel for applying filler

through the forces of surface tension. When this process is complete the resin may be cured by an appropriate oven cycle, such as 2 hours at 135 C or a longer time at room temperature.

► **Variations in Method**—In another type of application the coated filler can be much wetter, as by the addition of water, so that it forms a thick paste. This paste is pressed or molded into place around the part to be encapsulated, then dried to form the same type of hard, porous mass. This shell is then impregnated as before.

This alternative processing procedure has the advantage of not requiring any fancy mold or blowing technique, but is not so easily mechanized. It takes more time to dry and set the wet filler because



# Now a standard line

# POWERSTAT®

## VARIABLE TRANSFORMERS for HIGH FREQUENCY APPLICATIONS

— 1/3 the weight — 1/2 the size of 60 cycle units

Designed for use in high frequency control systems where weight and space must be minimized, these POWERSTATS are ideal for ship, aircraft, guided missile and other 400/800 cycle applications.

Listed are some of the standard line of POWERSTATS for high frequency applications. However, many high frequency requirements necessitate designing to individual needs. The Superior Electric Company will be pleased to work with you on the design of POWERSTATS to satisfy new or unusual needs.

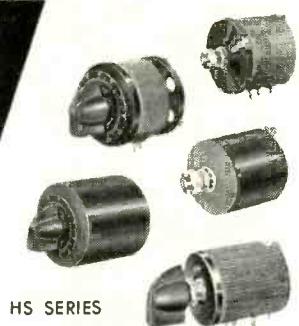

HS SERIES



HM SERIES



HL SERIES

INPUT		OUTPUT			MANUALLY-OPERATED MODELS				MOTOR-DRIVEN MODELS					
VOLTS	FREQUENCY CYCLES PER SECOND	VOLTS	MAXIMUM AMPERES	MAXIMUM KVA	TYPE OF CONSTRUCTION	TYPE	METHOD OF TURNING	APPROX. WEIGHT (POUNDS) NET	APPROX. WEIGHT (POUNDS) SHIPPING	TYPE	STANDARD MOTOR DRIVES	SPEED OF TRAVEL IN SECONDS	APPROX. WEIGHT (POUNDS) NET	APPROX. WEIGHT (POUNDS) SHIPPING
<b>SINGLE PHASE</b>														
28	400/800	0-28	2.0	.056	Open	3HS02UK	Knob	0.5	0.9					
28	400/800	0-28	4.0	.112	Open	3HS04UK	Knob	0.8	1.2					
120	400/800	0-120 or 0-140	1.0	.14	Open	1HS01UK	Knob	0.9	1.3					
120	400/800	0-28	2.6	.073	Open	1RHS03UK	Knob	#.6	1.0					
120	400/800	0-120 or 0-140	3.0	.42	Open Square Frame	1HMS03UK	Knob	2.4	2.8	DM1HMS03U	28 Volt D-C	60	4.5	5.1
										AM1HMS03U	120 Volt A-C, 400 Cycles	60	4.5	5.1
120	400/800	0-120 or 0-140	7.5	1.0	Open Square Frame	1HMS07UK	Knob	3.4	3.8	DM1HMS07U	28 Volt D-C	60	5.5	6.1
										AM1HMS07U	120 Volt A-C, 400 Cycles	60	5.5	6.1
120	400/800	0-120 or 0-140	15.0	2.1	Open	1HL15UK	Knob	11.4	14.0	DM1HL15U	28 Volt D-C	60	13.2	16.2
										AM1HL15U	120 Volt A-C, 400 Cycles	60	13.2	16.2
240	400/800	0-240 or 0-280	3.0	.84	Open Square Frame	2HMS03UK	Knob	2.4	3.8	DM2HMS03U	28 Volt D-C	60	5.5	6.1
										AM2HMS03U	120 Volt A-C, 400 Cycles	60	5.5	6.1
240	400/800	0-240 or 0-280	9.0	2.5	Open	2HL09UK	Knob	12.8	15.4	DM2HL09U	28 Volt D-C	60	14.6	17.6
										AM2HL09U	120 Volt A-C, 400 Cycles	60	14.6	17.6
<b>THREE PHASE</b>														
240	400/800	0-240 or 0-280	3.0	1.5	Open	2HMS03UK-3Y	Knob	7.6	8.5	DM2HMS03U-3Y	28 Volt D-C	60	9.3	10.5
										AM2HMS03U-3Y	120 Volt A-C, 400 Cycles	60	9.3	10.5
240	400/800	0-240 or 0-280	7.5	3.6	Open	2HMS07UK-3Y	Knob	10.6	11.6	DM2HMS07U-3Y	28 Volt D-C	60	12.3	13.6
										AM2HMS07U-3Y	120 Volt A-C, 400 Cycles	60	12.3	13.6
240	400/800	0-240 or 0-280	15.0	7.3	Open	2HL15UK-3Y	Knob	31.5	41.0	DM2HL15U-3Y	28 Volt D-C	60	38.0	45.0
										AM2HL15U-3Y	120 Volt A-C, 400 Cycles	60	38.0	45.0
480	400/800	0-480 or 0-560	3.0	2.9	Open	4HMS03UK-3Y	Knob	10.6	11.6	DM4HMS03U-3Y	28 Volt D-C	60	12.3	13.6
										AM4HMS03U-3Y	120 Volt A-C, 400 Cycles	60	12.3	13.6
480	400/800	0-480 or 0-560	9.0	8.7	Open	4HL09UK-3Y	Knob	30.0	45.5	DM4HL09U-3Y	28 Volt D-C	60	42.5	49.5
										AM4HL09U-3Y	120 Volt A-C, 400 Cycles	60	42.5	49.5

Be sure to see  
SUPERIOR ELECTRIC'S  
Mobile Display  
when it is in your area

Offices: Los Angeles, California • San Francisco, California • Toronto, Ontario, Canada • Miami, Florida • Chicago, Illinois • Baltimore, Maryland • Detroit, Michigan • New York, New York • Cleveland, Ohio • Dallas, Texas • Seattle, Washington



THE  
SUPERIOR ELECTRIC  
COMPANY  
208 BRADLEY AVENUE, BRISTOL, CONNECTICUT

Send new Bulletin P257H  Have your representative call

Name .....

Company .....

Address .....

City ..... Zone ..... State .....

# electronic counter

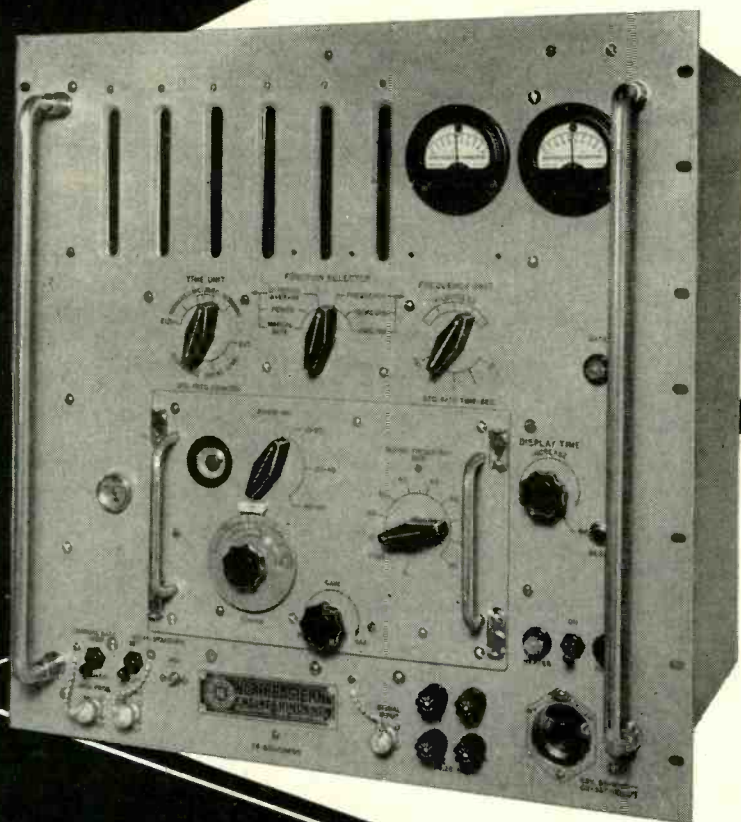

CAT. NO. — NE — 14-20 FM

ACCURATE • SIMPLE  
DIRECT READING  
INSTANTANEOUS  
RELIABLE

FREQUENCY MEASUREMENTS  
10 CPS to 220 MC; TIME  
INTERVAL 1 MS to 100 DAYS;  
PULSE LENGTH, REP, RATES,  
FREQUENCY DRIFT

**northeastern**  
Manchester



**engineering**  
New Hampshire

PRODUCTION TECHNIQUES

(continued)

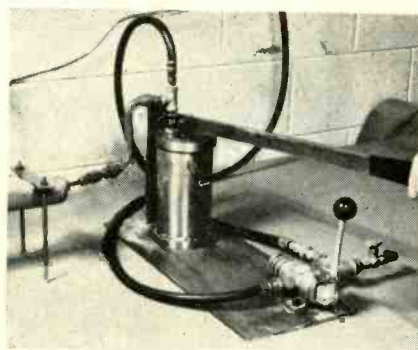

STEP 5. Setup for blowing filler into mold, followed by hot, dry air

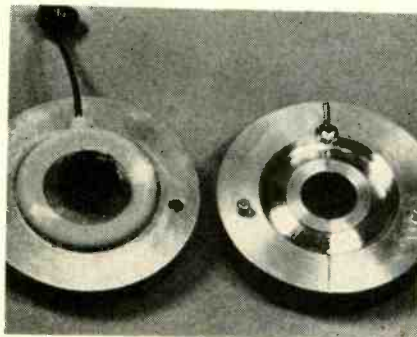

STEP 6. Coil ready to be removed from mold after bonding filler

of the larger volatile content. The paste filler is recommended where complex geometry of windings and laminations is involved yet only a liquid resin can adequately penetrate the irregular voids. After the paste is dried, final shaping can be completed and excess paste removed from the inner surfaces of laminations. When the liquid resin is allowed to impregnate and cure, the job is completed without the use of any mold at all.

In still another type of application the object is to fill a can or other container which holds the part. Here no mold is required nor is any useful purpose served by preliminary bonding of the filler particles. The filler is poured dry into the space to be filled. The resin is then allowed to impregnate, preferably from the bottom up so as to avoid air entrapment. This still gives the advantages of associating the catalyst with the filler rather than having it mixed with the resin phase.

► **Fillers**—A high filler content can be achieved by this method. In the coil example, the filler content is 82 percent by weight and ap-





... by and for the technician, \$1.50 net

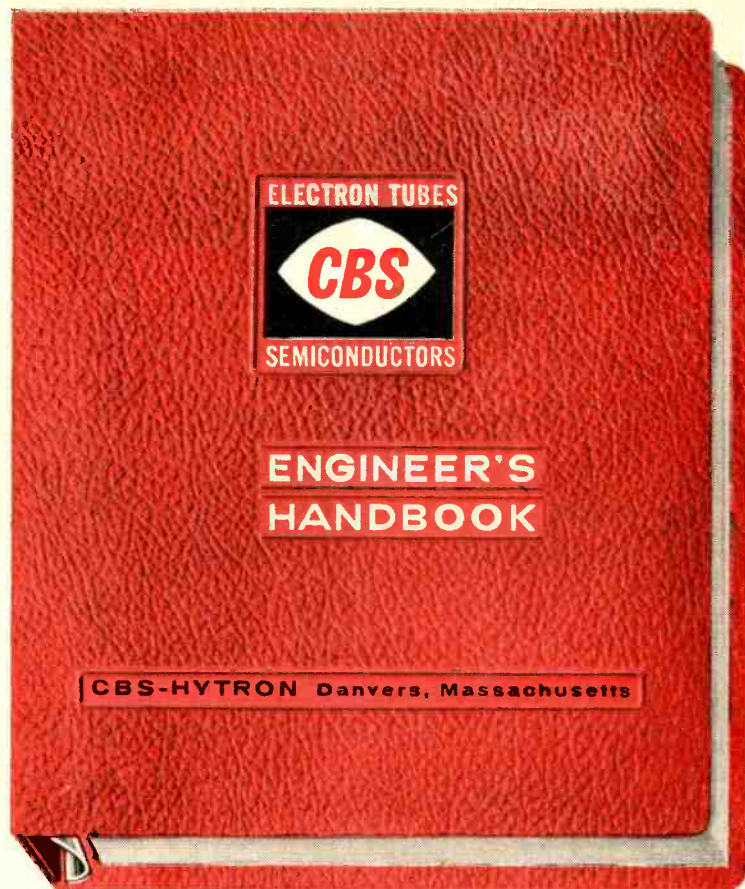

... by and for the engineer, \$7.50 net

# Two new CBS handbooks

The new CBS Technician's Handbook and Engineer's Handbook are complete. They contain data for receiving, special and picture tubes as well as crystal diodes and transistors. Designed for on-the-job use, they are single, compact, handy volumes that lie flat. They feature modern styling for quick, easy reference. Supplementary services are available. Ask to see these Handbooks at your CBS Tube distributor's. You will want them both.

## CHECK THESE FEATURES

### Technician's Handbook

- Comprehensive data for all popular types
- Reference data for seldom-used types, grouped by application
- All popular special-purpose tubes and semiconductors
- 450 pages
- Handy 5¼ by 9 inches
- Rugged plastic binder
- Appendix especially prepared for service technicians

### Engineer's Handbook

- Complete RETMA engineering design data
- Seldom-used types tabulated for quick reference
- 300 two-color design curves
- 650 pages, two colors
- Handy 8¼ by 9¾ inches
- 16-ring metal binder
- Appendix includes description of terms, symbols, characteristics ratings, etc.

*Reliable products  
through Advanced-Engineering*



**tubes • semiconductors**

**CBS-HYTRON**, Danvers, Massachusetts  
A Division of Columbia Broadcasting System, Inc.

# PANELSCOPE

by

**Waterman**

**AUTOMATIC  
OR MULTI-PURPOSE  
PORTRAYAL**



## ANOTHER EXAMPLE OF **Waterman** PIONEERING...

The Waterman **PANELSCOPE** is a new concept in miniaturized built-in cathode ray tube oscilloscope gaining wide use as an integral part of electronic equipment. A unique design has permitted its use in commercial products, factory test stands, field trouble shooting kits, system monitors and many other applications.

The **PANELSCOPE** compactness (5¼" x 5-3/16" and 10" depth at 5 lbs.) is coupled with the following features:

- **SIMPLICITY OF OPERATION** — Can be supplied so that a twist of a single rotary switch provides a synchronized pattern of desired incoming signal (up to 9 circuits) against proper linear time base. This is ideal for monitoring and trouble shooting, as it removes the need of fiddling with knobs as is done now on general purpose oscilloscopes. The static controls, such as beam, focus, positioning, and graticule brightness, are located in tube escutcheon.
- **AVAILABLE CIRCUITS** — A wide variety of — signal amplifiers with response from dc to megacycles and sensitivities from 5 millivolts — synchronized or triggered linear time base generators from ½-cycle (and lower if need be) to 2 microseconds — can be specified by you to fit your needs for any particular equipment.
- **FLEXIBLE DESIGN** — The basic **PANELSCOPE** consists of the cathode ray tube and high voltage supply packaged in the standard case without the panel mounted controls. The **PANELSCOPE** can also be supplied fully wired and tested with chosen signal amplifier, linear time base generator and attendant sync. amplifier.
- **POWER REQUIREMENT** — Less than 10 watts of line power for built-in high voltage supply — The required B+ and heater current is determined by your requirements. For those cases where B+ and heater power is not available, auxiliary **PANELPACK** can be supplied.

There is a place in your equipment for Waterman **PANELSCOPE**, a custom built oscilloscope at production prices, although your needs may be for but one or many. A Waterman representative will help you fit a Panelscope to your requirements.

## WATERMAN PRODUCTS CO., INC.

PHILADELPHIA 25, PA.  
CABLE ADDRESS: POKESCOPE

MANUFACTURERS OF

**POCKETSCOPE\***

**PULSESCOPE\***

**RAKSCOPE\***

**RAYONIC\*** Cathode Ray Tubes  
and Other Associated Equipment

\*T.M. REG.

MEMO...  
Write for details today!



**WATERMAN PRODUCTS**



**STEP 7. Coil resting in small dish absorbs resin quickly**

proximately 65 percent by volume which is appreciably higher than can be obtained by ordinary mixing procedures without obtaining a very thick paste that is useless for most purposes. An inexpensive organic filler here gives obvious advantages in raw material economy, as well as in a lowered thermal coefficient of expansion. For the examples shown the coefficient is about 20 parts per million per deg C, so that the cracking common with other rigid organics surrounding metal parts may be avoided.

Other advantages of higher filler content are higher thermal conductivity and very low shrinkage of the resin on cure. The high filler content is also favorable for reducing moisture absorption, weight loss on heat aging and flammability.

With the coated filler technique a mold is required at most for only a few minutes in the production of each part. This is especially important with inexpensive components made in large quantities.

► **Impregnating** — When resin is introduced to coated fillers for impregnation by capillary action no vacuum is required, yet dielectric strength and corona starting levels



# UNION



## NEW SERVO-RATIO MULTIMETER

Combines all the functions of an AC-DC voltmeter, ohmmeter and AC-DC ratiometer in one compact portable unit

Here is a new, highly accurate test instrument designed to make life easier for those who work with computers and other electronic and electrical devices. It measures AC-DC ratios, absolute AC-DC voltages and resistance. You can also measure the gain of operational amplifiers using the 0° phase output provided.

The Servo-Ratio Multimeter computes voltage ratios by dividing the voltage to be measured by the reference voltage obtained from the computer. It is a high-impedance instrument and utilizes a motor-driven, position-type servo mechanism. Average time to obtain a reading is three seconds. Simplification and reliability are obtained through the use of printed circuits.

The front panel contains a four-digit illuminated drum counter for readout, phase or polarity indicating lights, function switch, ON-OFF

switch, range switch, 0° phase ratio selector, input terminals and 0° phase output terminals.

The Servo-Ratio Multimeter is compact and easy to handle. It has an aluminum case and weighs only 10 pounds. The instrument can be operated in a horizontal or vertical position and has a unique carrying handle that serves as a tilt-stand when the unit is used horizontally. Write for Product Description 2005.

### SPECIFICATIONS

Power Consumption: 50 Watts, 110 Volts, 60 cps.  
Reference Voltage: DC or 60 cps AC;  $\pm 10$  Volts to  $\pm 100$  Volts across 8.7K Ohms Load.

Functions	Range
Ratio, AC	0.001 to 1.000 $\pm 0.1\%$ in 1 range
Ratio, DC	0.001 to 1.000 $\pm 0.1\%$ in 1 range
60 cps AC Voltage	1 Volt to 1000 Volts full scale $\pm 1.0\%$ in 4 ranges
DC Voltage	1 Volt to 1000 Volts full scale $\pm 1.0\%$ in 4 ranges
Ohms	10K Ohms to 10 Megohms full scale $\pm 1.0\%$ in 4 ranges
Gain	0.01 to 1000 in 4 ranges

See our exhibit at the Wescon Show, Booths 810-811.

 **UNION SWITCH & SIGNAL**

DIVISION OF WESTINGHOUSE AIR BRAKE COMPANY

PITTSBURGH 18, PENNSYLVANIA



PORTABLE AND COMPACT—Weighs only 10 pounds. Size: 7 $\frac{7}{8}$ " x 5 $\frac{1}{2}$ " x 11-13/16".

SIMPLIFIES TESTING—Eliminates need for many other instruments. Has digital readout counter.

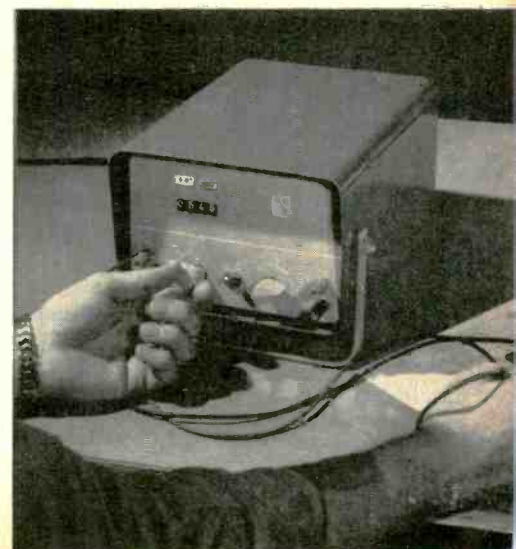



**Here's the fastest way to produce finished wire leads!**



Allen-Bradley Co., producers of motor controls, use several Artos CS-6 automatic wire cutting and stripping machines in their Milwaukee plant.

# high speed ARTOS AUTOMATIC MODEL CS-6

**3000 STRIPPED WIRE LEADS** in one hour ...each precision-cut with both ends perfectly stripped. That's the speedy pace set by the Artos CS-6 in producing wire leads up to 15 inches in length! Production rates vary in proportion to the length cut.

Highly accurate machine operation reduces work spoilage to an absolute minimum. Errors due to the human element are eliminated. *There is no cutting of strands or nicking of solid wire.*

### PROVED PERFORMANCE

Time-consuming hand stripping jobs which once were a bottleneck in many plants are gone forever. As a result, Artos automatic wire strippers are paying their way in the mass production of television and radio sets, electrical appliances, motor controls and instruments of all kinds.

Plan now to cut wire stripping costs in your plant...with the high speed, automatic Artos CS-6.

### CS-6 CAPACITY

**Finished Wire Leads Per Hour:**  
lengths to 15", 3000; 64"-97" lengths, 500.

**Stripping Length:** 1½" max. both ends.

**Cutting Length:** max., 97"; min., 2"; special, 7/8".

**MEASURES,  
CUTS and  
STRIPS  
wire, cord  
and cable  
at speeds up to  
3000  
pieces per hour**

2-Conductor Twisted Wire

Single Conductor Solid Wire

2-Conductor Parallel  
Stranded Wire

300 Ohm Television Wire

SJ Cord

Heater Cord

Braided Cord With  
Rubber Jacket

**WRITE FOR  
BULLETIN**

Descriptive technical sheet tells how the Artos CS-6 can save you money, manpower and time.



have been better than could be accomplished by vacuum impregnation. There are some impregnation applications which obviously cannot be solved by this method, however. Since the resin is catalyzed in the cure primarily by contact with the bonded filler, the filler must be present nearly everywhere that resin is expected to enter and cure. Resin which merely passes through the bonded filler and further impregnates internal voids will cure satisfactorily within limits, but a large coil could not be fully impregnated by this approach if it had on the outside only a thin skin of the catalyzing bonded filler.

### Rat Trap Holds Plugs

AN ORDINARY rat trap with trigger and pan removed serves as an ideal universal holding fixture for all sizes of AN connectors at Transdyne Corp., Maspeth, N. Y. The jaw of the trap is wrapped with



Taped jaw of trap holds flat connector for soldering leads



Large circular AN connector is held firmly even when square mounting flange is not resting on base of trap

electrical tape to minimize slippage and prevent scratching of connectors while they are being held for cabling and soldering operations. Details of this simple technique were furnished by J. A. Simms, production engineer of the firm.

**ARTOS ENGINEERING CO.**

Automatic Wire Cutting and Stripping

2743 South 28th Street • Milwaukee 46, Wisconsin



*Constantin* GLASS-TO-METAL SEALS



# special sealing techniques

## *Insure* quality

The measure of any glass-to-metal seal's quality is its ability to withstand extremes of temperature, shock and vibration. And Constantin's special sealing techniques insure quality seal performance in the most difficult applications.

Inspection and quality control are of prime importance at Constantin, too . . . six, separate check points are maintained for the critical evaluation of each and every seal that comes down the production line.

Experience counts . . . and Constantin's long experience in the design and fabrication of both standard and specialized all-in-one assemblies, end seals, transistor mounts, unit headers, crystal covers, and connectors has set the norm for quality in the glass-to-metal industry.

This versatility of manufacture and experience can be yours.

Write today for more information.

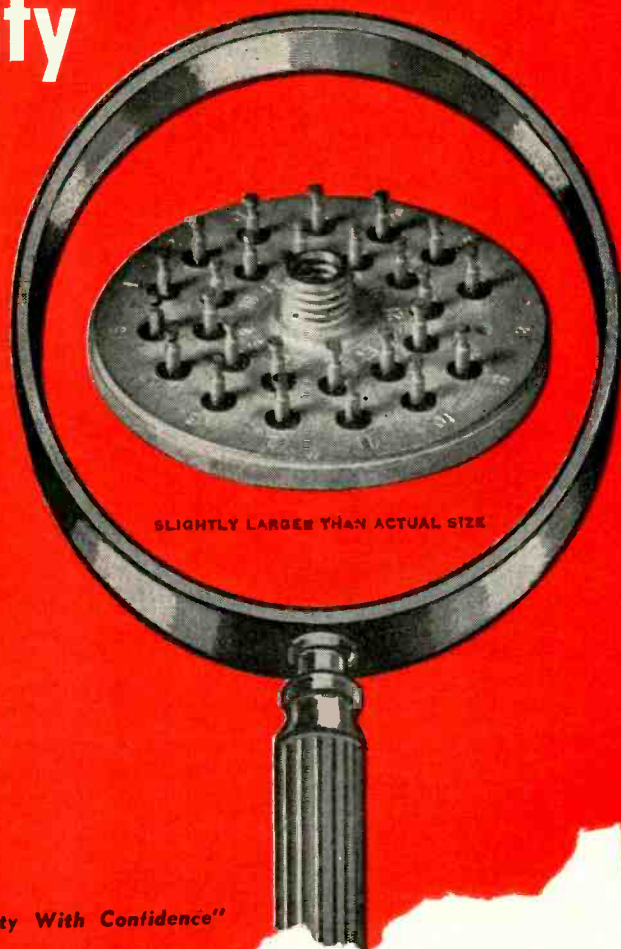

*"Quality With Confidence"*



# L. L. Constantin & Co.

**MANUFACTURING  
ENGINEERS**

Route 46, Lodi, N. J. • 187 Sargeant Ave., Clifton, N. J.

TRANSISTOR MOUNTS • COMPRESSION HEADERS • CRYSTAL BASES • CONNECTORS • MINIATURIZATION

SINGLE TERMINALS • END SEALS

# New Products

Edited by WILLIAM P. O'BRIEN

67 New Products and 41 Manufacturers' Bulletins Are Reviewed  
. . . Control, Testing and Measuring Equipment Described and  
Illustrated . . . Recent Tubes and Components Are Covered

## NONDESTRUCTIVE TESTER

checks coating thickness

UNIT PROCESS ASSEMBLIES, INC., 61 E. 4th St., N. Y. C., New York. Dermitron model D-2 nondestructive coating thickness tester is a portable instrument for both laboratory and production use. It gives fast, accurate and direct readings of virtually any coating on any base, including: metal coatings (such as plating) on



metal base; nonmetallic coatings (such as paint, anodizing, porcelain) on metal base; and metal films on nonmetallic base (plastics, ceramics).

Dermitron D-2 comes with four measuring probes for extra wide thickness ranges from thin to thick deposits, and requires only  $\frac{1}{8}$  in. circle-area for measurement. It can be used for sorting and matching of metals and alloys. **Circle 401 inside back cover.**

## LAB POWER SUPPLY

for work with transistor circuits

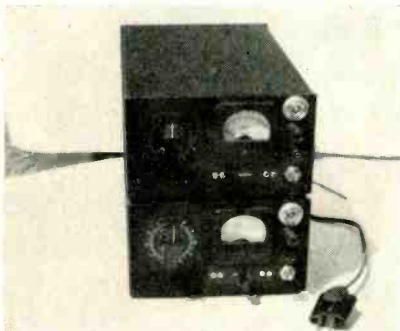

VECTOR ASSOCIATES, 1007 Atlantic Avenue, Brooklyn, N. Y., announces their Model L974 variable power supply especially designed for laboratory work with transistor circuits. The unit offers three continuously variable ranges, 0 -7.5 v, 0 -37.5 v and 0 -75 v, all at 1.5 amperes.

A Superior Electric Powerstat allows voltage control of the input to a full-wave rectifier utilizing

GE germanium diodes. Filtering is provided by a swinging choke and a 1,000  $\mu$ fd filter capacitor. A  $2\frac{1}{2}$  in. Simpson meter indicates the output voltage. Low output impedance is maintained throughout each range, never exceeding a value of five ohms.

Physically the units are well shielded and designed to allow stacking. Dimensions are: 4 in. high, 7 in. wide, 12 in. deep. In quantities of one to ten, the price is \$140. **Circle 402 inside back cover.**

## CIRCUIT BREAKERS

shunt and relay style

AIRPAX PRODUCTS CO., Ft. Lauderdale, Florida, has available shunt and relay style circuit breakers. They use the same magnetic time-delay trip mechanism as the series style breakers. Trip level is independent of temperature in all three styles.

In series style breakers, the release coil is in series with the contacts and operates when the load current exceeds 135 percent of normal rating. In shunt style

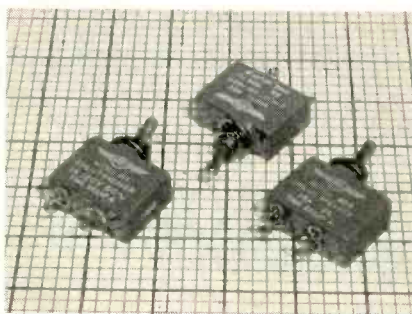

breakers the release coil can be shunted externally; for example,

by a rheostat to adjust trip level. In relay style breakers, the release coil is entirely independent of the contacts. Thus, for example, the release coil can be actuated by the d-c output of a power supply and the contacts can control the a-c input to the supply.

Release mechanism is actuated reliably by as little as 50 ma. Units are available with standard ratings to 10 amperes. When a breaker opens, the toggle returns to its OFF position giving trip indication. The action is trip free



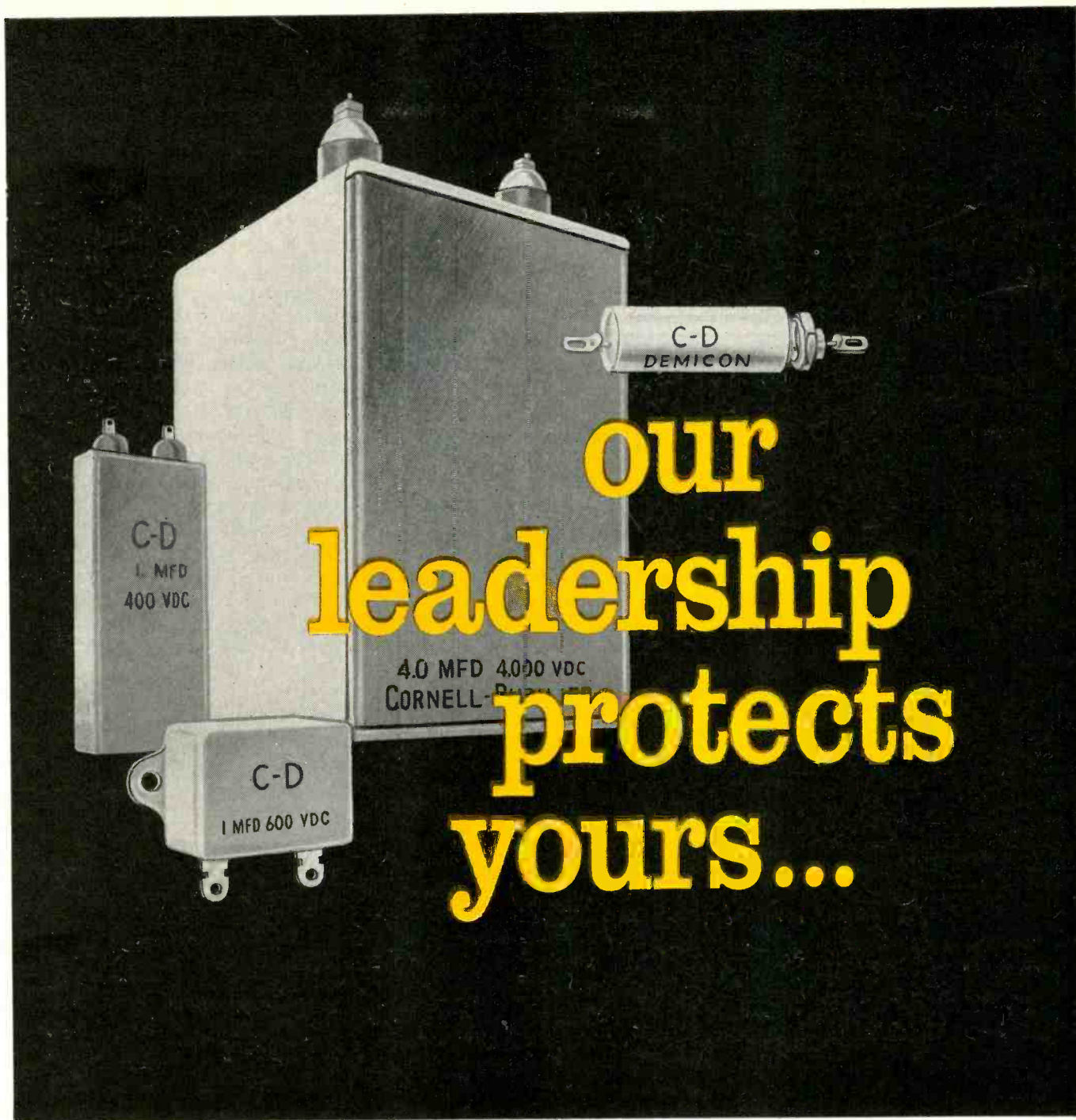

Our reputation as the world's most Consistently Dependable producer of capacitors has been maintained for over 46 years. But *any* reputation can be lost overnight. That's why we resist the temptation to gain temporary advantage through methods that risk *our* reputation or yours. C-D's Consistently Dependable products can mean PLUS dollars to you.

**Widest Choice of Impregnants and Dielectrics to meet your needs:**  
More than a score of liquid and solid impregnating media

and dielectrics, including Polystyrene, Mylar\*, Teflon, metallized paper and metallized Mylar, are readily available to meet your temperature, size and other circuit requirements. Operating temperature ranges from  $-40^{\circ}\text{C}$  to  $+85^{\circ}\text{C}$  and  $-60^{\circ}\text{C}$  to  $+200^{\circ}\text{C}$ . Whatever your capacitor problems, depend on Cornell-Dubilier to fulfill your needs most promptly, most economically and most satisfactorily.

*Write for catalog to Cornell-Dubilier Electric Corporation, South Plainfield, New Jersey.*

(\*DUPONT TM)



CONSISTENT HI-DEPENDABILITY  
**CORNELL-DUBILIER CAPACITORS**



SOUTH PLAINFIELD, N. J.; NEW BEDFORD, WORCESTER & CAMBRIDGE, MASS.; PROVIDENCE & HOPE VALLEY, R. I.; INDIANAPOLIS, IND.; SANFORD, FUGUAY SPRINGS & VARINA, N. C.; VENICE, CALIF.; & SUB.; THE RADIAN CORP., CLEVELAND, OHIO; CORNELL-DUBILIER ELECTRIC INTERNATIONAL, N. Y.

(contacts cannot be held closed manually in presence of overload). Time delays permit normal starting inrushes, operating surges and sequencing transients to pass without ripping the breaker. Two

standard delays are available for protecting electronic equipment or equipment with blowers and small motors; faster action is available if needed.

These hermetically sealed break-

ers withstand 50 g shock, vibrations of 10 g to 1,000 cps and operate from -55 to +100 C (-67 to +212 F). Contacts are rated for 50 v d-c or 120 v rms at 60 or 400 cps. **Circle 403 inside cover.**

## FREQUENCY INDICATOR

and printing recorder

ELECTRO-PULSE, INC., 11861 Teale St., Culver City, Calif. Model 7341B frequency indicator, with its associated desk model printer, is a low price range instrument for the measurement of frequency, velocity, rpm and the like, with continuous monitoring and printed readings.

Set-up and operation by non-technical personnel is feasible due to the instrument's simplified controls and high reliability. With the input signal source connected,

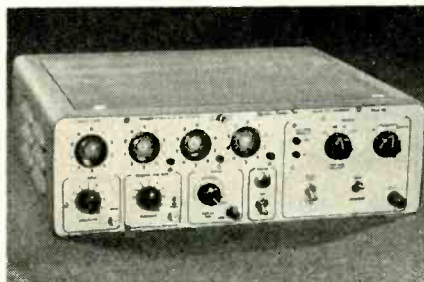

the unit counts events during the 0.1 sec, 1 sec or 10 sec time bases available, at rates up to 100,000 per sec. The measurement is then

displayed on the glow transfer counting tubes and may be recorded on the standard printer tape. Automatic recycle or single reading modes of operation are available.

A self-test for checking time bases and counters is provided and the unit may be used with an external time base. Input sensitivity is 50 mv, allowing operation directly from common transducers.

Modular printed circuit construction, relay rack panel adaptability, and complete internal accessibility are additional features. **Circle 404 inside back cover.**

## WIRE MARKERS

aluminum foil type

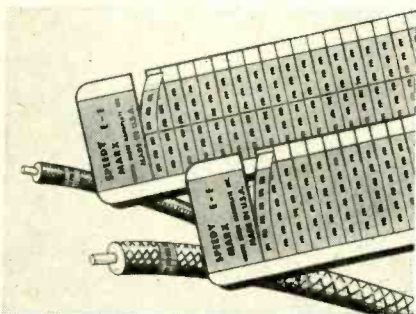

NORTH SHORE NAMEPLATES, INC., 214-27 Northern Blvd., Bayside 61, N. Y. A new line of aluminum foil wire markers has been added

to the group of self-sticking products marketed under the trade name Speedy Marx. Aluminum markers are furnished on quick-release dispensing cards which have been pre-cut for easy handling, and can be applied instantly without tools.

Flexible aluminum markers offer users double sticking action. A thermosetting adhesive retains its bonding action up to temperatures of 350 F, and the mechanical action of the aluminum as it wraps around wiring will remain

unaffected by solvents, grease or coolants. Even large diameter wire and cable, or pipe and tube, can be coded with aluminum markers.

A transparent plastic coating is applied to marker surfaces after imprinting to protect symbols against abrasion, water or dirt. Symbols or markings may be specified as required, or conventional markings ordered from stock. Two sizes are available: 1½ in. markers for wires over ¼ in. o-d, ¾ in. markers for wires under ¼ in. o-d. Special sizes, shapes and colors can also be furnished. **Circle 405 inside back cover.**

## POWER SUPPLY

magnetic amplifier type

KEPCO LABORATORIES, INC., 131-38 Sanford Ave., Flushing 55, N. Y., has introduced the first in a series of new tubeless magnetic amplifier voltage-regulated power supplies. Model KM236-15 is a 2-36 volt, 0-15 ampere continuous duty d-c supply.

In the 2-36 v range, the output voltage variation is less than 0.5 percent for line fluctuation from

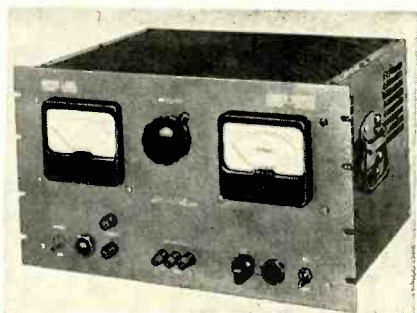

105-125 v, and less than 0.5 percent or 25 mv, whichever is greater, for load variations from minimum to maximum current. Ripple is less than 0.5 percent or 25 mv rms.

Other features are: (1) a short circuit will not damage the supply; (2) full current may be drawn at any voltage from 2-36 v; (3) the unit will operate in the 57-63 cps frequency range.

Height of the unit is 12¼ in.; width, 19 in.; depth, 17 in. This



**KEARFOTT 3-Gyro Stable Platform**

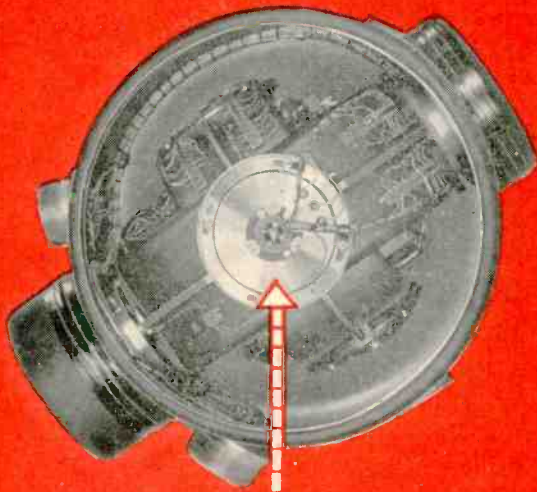

11 INCHES  
25 POUNDS

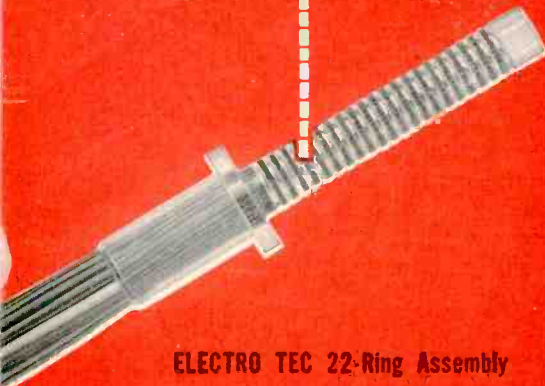

**ELECTRO TEC 22-Ring Assembly**



# The "Impossible" . . . . by Kearfott Slip Ring Assemblies . . . . by Electro Tec

**BY KEARFOTT:** Smallest 3-gyro stable platform ever produced . . . Housed in an 11 inch sphere . . . Total weight: 25 pounds. Capable of providing vertical outputs with a maximum error of 7 minutes under all dynamic flight conditions. Sustaining such accuracy for thousands of hours of operation in United States Navy and Air Force aircraft.

**BY ELECTRO TEC:** 5 Slip Ring Assemblies, having as many as 22 contact rings on a small diameter . . . Keep torque friction to minimum . . . Concentration of many rings in minimum space permits further miniaturization of related components . . . Aids overall size and weight reduction . . . Optimum electrical performance achieved by ring contact material of 24k. fine gold (approximate hardness, 120 Brinell) . . . These characteristics help Kearfott — and others — attain ultra-reliability — and make possible the "impossible"!

For further information write for fully illustrated brochure to

PAT. NO. 2,696,570  
FOR. PATS. PEND.



**ELECTRO TEC CORP.** South Hackensack, N. J.

*Products of Precision Craftsmanship*



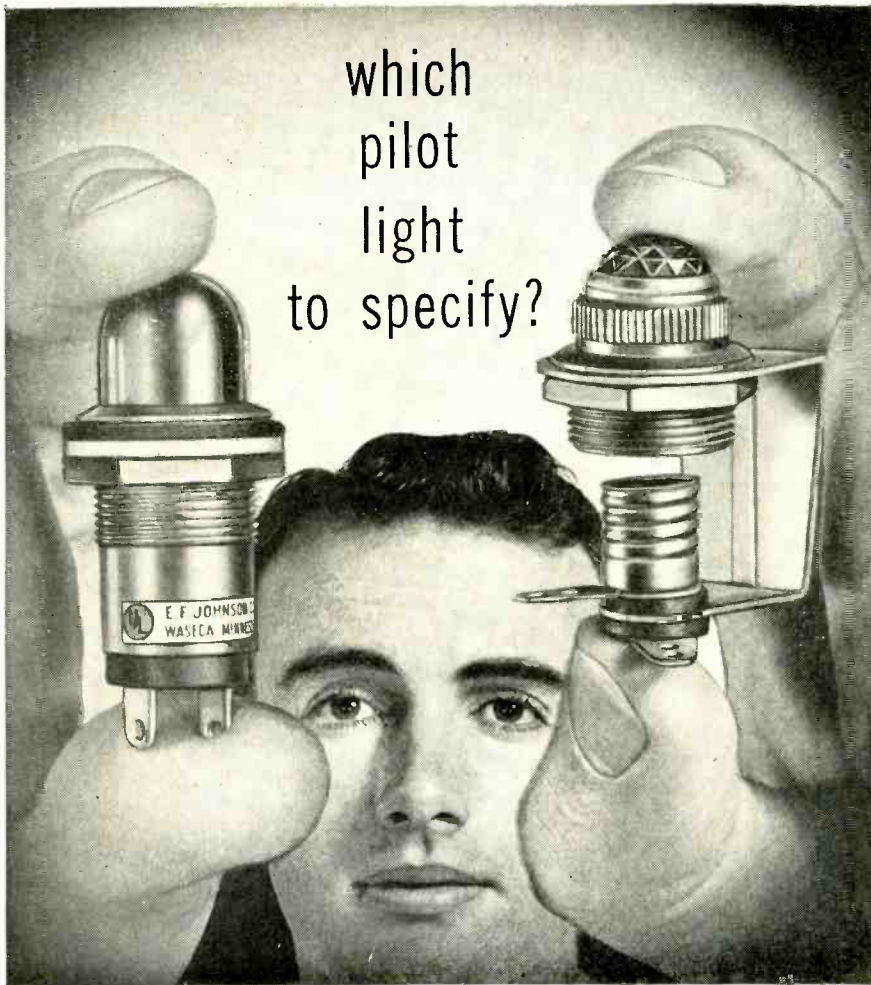

which  
pilot  
light  
to specify?

here's a  
quick, easy way  
to find the  
answer!

Save valuable specification time by selecting your panel indicators from Johnson's "preferred" line. This group contains over 47 separate assemblies carefully selected from Johnson's standard line by many of the nation's top design and development personnel. Available in a wide variety of types, these "preferred" units are immediately available at parts distributors throughout the country, for original equipment or in-the-field replacement. Write for your free copy of Johnson's newest pilot light specification catalog — see how easy it is to select the *right* pilot light . . . fast!



free!

New pilot light catalog — contains complete specifications, prices and technical data . . . everything you need to select the proper unit for original equipment or in-the-field replacement.

Available types include: continuous indication neon types; models for high and low voltage incandescent bulbs; standard or wide angle glass and lucite jewels in clear, red, green, amber, blue or opal. Specials, including those meeting military specifications are also available in production quantities.

supply is also available in 30 and 50 ampere versions. Circle 406 inside back cover.

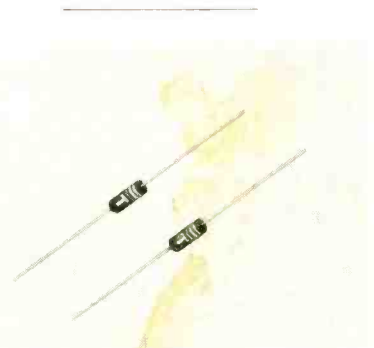

**SILICON DIODES**  
for computer applications

TRANSITRON ELECTRONIC CORP., Melrose 76, Mass., has available a new line of silicon diodes which are particularly useful in military computers where high temperatures are encountered. Operating voltages extend to 200 v, and no derating is necessary up to their maximum temperature of 150 C. With switching times as fast as 0.3  $\mu$ sec or less, these diodes can often directly replace germanium or vacuum types. High inverse resistance and forward conductance, combined with their fast switching and high temperature properties, allow maximum flexibility in design.

Manufactured using Transi-tron's subminiature glass package, the fast switching diodes can be used under the most severe environmental conditions. All units are subjected to temperature cycling and storage to insure reliable performance. Bulletin TE-1350 provides complete engineering specifications. Circle 407 inside back cover.

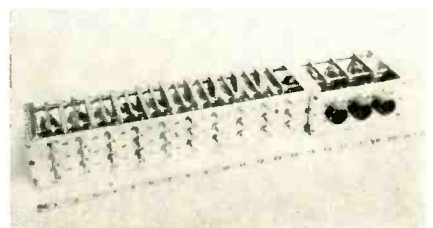

**ROTARY SWITCH**  
for video and pulse use

THE DAVEN Co., Livingston, N. J., has available a new wide band



**E. F. Johnson Company**

2308 SECOND AVENUE S. W. • WASECA, MINNESOTA



## Varian Strip Chart Recorders

# POTENTIOMETER PERFORMANCE\* AT MODERATE COST



**Varian G-10** — Portable for laboratory or bench use where chart accessibility is of prime importance. Base price \$340.

**Varian G-11** — For panel, rack or portable use; designed for OEM, lab or field for long-term monitoring. Base price \$450.



The servo-balance potentiometer method has long been used in expensive recorders to achieve superior stability, sensitivity, ruggedness and high input impedance. Use of servo balancing systems assures full realization of these inherent advantages by providing ample power independent of the source being measured. Now Varian offers you recorders of moderate cost using this time-proven principle.

### VARIAN SPECIFICATIONS:

- Spans as low as 10 mv
- Limit of error 1%
- Maximum source resistance 50K ohms or higher
- Balancing times: 1 second or 2.5 seconds on G-10; 1 second on G-11

*Varian recorders are sold and serviced throughout the free world by representatives in principal cities.*

WRITE TODAY FOR COMPLETE SPECIFICATIONS



PALO ALTO 1, CALIFORNIA

Varian Associates manufactures Klystrons, Traveling Wave Tubes, Backward Wave Oscillators, Linear Accelerators, Microwave System Components, R. F. Spectrometers, Magnets, Magnetometers, Stalos, Power Amplifiers and Graphic Recorders and offers research and development services.



## CLEVELITE\*

### Phenolic Tubing

... has proven dependability. It is quality engineered to meet virtually every requirement in the electronic and electrical fields.

Clevalite has high insulation resistance, exceptional chemical properties and good machinability to give product performance at its best. Available in diameters, wall thicknesses and lengths for your particular requirements.

The combined electrical and physical properties of Clevalite are essential to make your product better ... at lower costs!

We also make a complete line of kraft, fish paper, asbestos and acetate tubing.

Fast, dependable deliveries at all times!

Write for your copy of our latest illustrated brochure.

\*Reg. U. S. Pat. Off.

**THE CLEVELAND CONTAINER COMPANY**

6201 BARBERTON AVE. CLEVELAND 2, OHIO

**PLANTS AND SALES OFFICES:**

CHICAGO • DETROIT • MEMPHIS • PLYMOUTH, WIS. • OGDENSBURG, N.Y. • JAMESBURG, N.J. • LOS ANGELES

ABRASIVE DIVISION at CLEVELAND, OHIO

Cleveland Container Canada, Ltd., Prescott and Toronto, Ont.

**Representatives:**

NEW YORK AREA: R. T. MURRAY, 604 CENTRAL AVE., EAST ORANGE, N. J.

NEW ENGLAND: R. S. PETTIGREW & CO., 62 LA SALLE RD., WEST HARTFORD, CONN.

CHICAGO AREA: PLASTIC TUBING SALES, 5215 N. RAVENSWOOD AVE., CHICAGO

WEST COAST: IRV. M. COCHRANE CO., 408 S. ALVARADO ST., LOS ANGELES



video and pulse switch, No. 5583. It is designed for use at frequencies up to 4.5 mc. The electrical characteristics of this switch call for dpdt operation of 10 separate circuits with very strict isolation requirements. The 10 rear decks of the switch are all completely isolated from each other by the use of sectional shielding and r-f grounding fingers. Each of these 10 decks was also designed to eliminate capacitive or inductive coupling effects within each deck.

The three front decks of this unit are designed for the purpose of switching filament voltages, line voltages and B+ voltages and the like. The entire switch is silver plated to provide excellent r-f characteristics and all contacts and wipers are of coin-silver to minimize contact resistances. Overall dimensions are 4½ in. by 3 in. by 22 in. in depth. Circle 408 inside back cover.

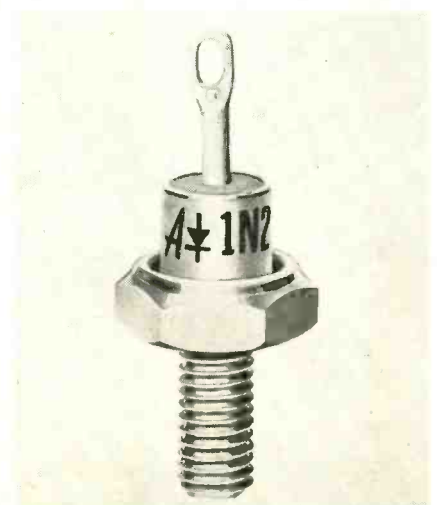

### SILICON RECTIFIERS

operate from -55 C to +150 C

GENERAL INSTRUMENT CORP., Automatic Mfg. Division, 65 Gouverneur St., Newark 4, N. J. Designed and manufactured to the extremely rigid requirements of MIL-E-1, four JAN types of silicon rectifiers (1N253, 1N254, 1N255 and 1N256) are now in large-scale production. The new rectifiers, which cover the range of 100 to 600 v peak inverse, are of alloyed junction construction with all-welded hermetic seal. Developed for use in all types of



# NEW



MINIATURIZED MICROWAVE ISOLATORS such as this new Raytheon X band unit weigh as little as 6 ozs.

## MICROWAVE FERRITE ISOLATORS

—New designs now available for several bands

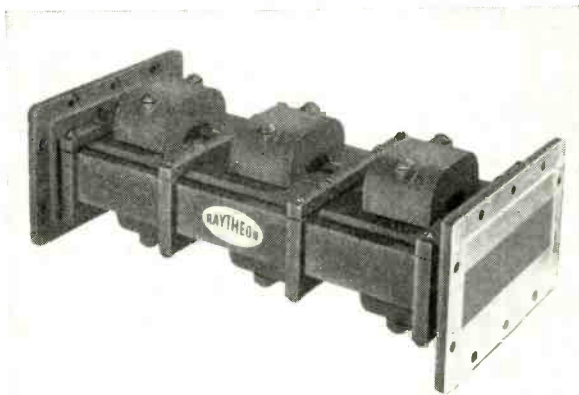

NEW HIGH POWER L-BAND ISOLATOR, first of its kind, typifies Raytheon leadership in microwave ferrite materials and devices.

You'll want to learn more about Raytheon's new full line of microwave ferrite load isolators as well as other devices now available commercially for the first time. Included in the line is a completely new L-band isolator, the first of its kind ever built. There are also units for S, C, X, K<sub>v</sub>, and K<sub>u</sub> bands.

RAYTHEON'S TYPE R-151 FERRITE MATERIAL is available for Faraday rotation devices in X and K band frequencies and for resonant-type isolators in S through K bands. Other compositions are available for various applications.

WRITE TODAY for technical data sheets on standard Raytheon microwave ferrite devices and material. Please state your specific requirements for more complete data. Write to W. C. Plouffe at address below.

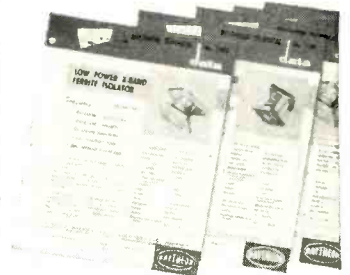

*Excellence in Electronics*

**RAYTHEON MANUFACTURING COMPANY**

**SPECIAL MICROWAVE DEVICE GROUP  
28 SEYON STREET, WALTHAM 54, MASS.**

See the Raytheon ferrite exhibit at Wescon.

# G-M Servo Motors...

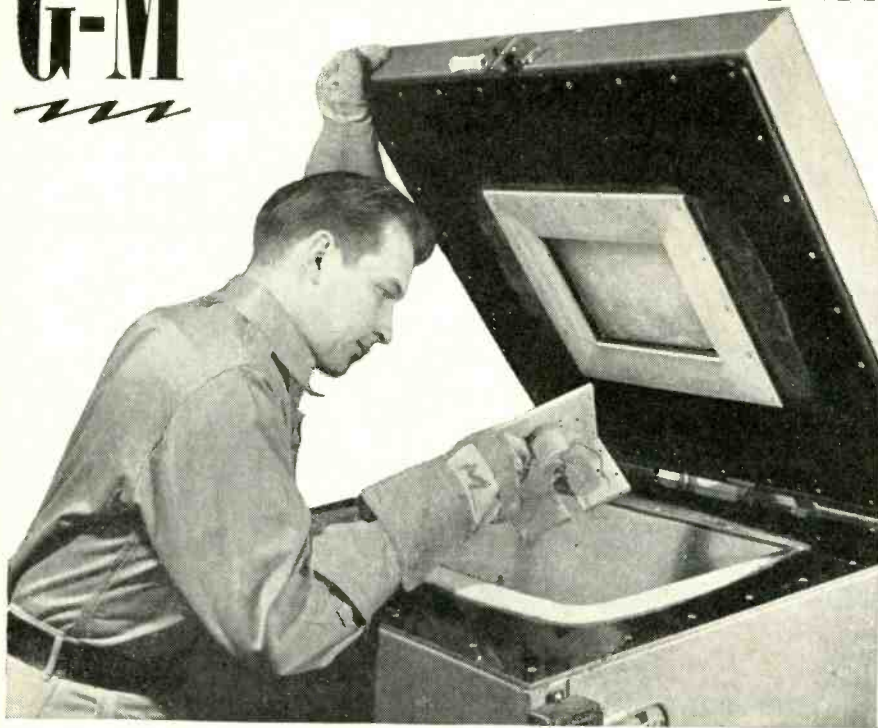

NEW PRODUCTS

(continued)

military equipment where the basic limitations of selenium, germanium and vacuum tube rectifiers must be overcome, these units are designed for high reliability under the most severe environmental conditions of moisture, vibration fatigue, high acceleration vibration, centrifuging, shock and temperature cycling. They have been successfully operated at temperatures ranging from  $-55\text{ C}$  to  $+150\text{ C}$  and they can be stored to temperatures ranging from  $-65\text{ C}$  to  $+180\text{ C}$ . Circle 409 inside back cover.



## DIGITAL VOLTMETER

various models available

ELECTRONIC COMPUTER Co., 6191 Ridge Ave., Philadelphia 28, Pa., has available various models of an all electronic analog to digital converter for data reduction systems and general voltage measurement applications. The unit pictured is model 100A with 0.1-percent accuracy or  $\pm 1$  count and readings as high as 70 per sec. Input is 0 to 130 v. The unit supplies power for an external scale changing amplifier. It can be used as a counter, timer or an events per unit time instrument. It contains a decimal point locator and both decimal and binary coded output (1-2-2-4). Four-digit 0.01-percent accuracy models are also available. Circle 410 inside back cover.

## MICROWAVE ANTENNA

for the 100-500 mc band

AINSLIE CORP., 312 Quincy Ave., Quincy, Mass., is offering a newly developed model CF-121M 12-ft diameter microwave antenna for the 100 to 500-mc band, with a

- Tested** at 65 degrees below zero
- Proved** in other environmental tests
- Guaranteed** to meet all mil. environmental specs.

### 4 GOOD REASONS WHY G-M SERVO MOTORS SERVE YOU BEST!

- 1 G-M servo motors are available in standard sizes.
- 2 G-M servo motors can be modified to meet specific circuit requirements.
- 3 Creative engineering in designing special servo motors with special characteristics.
- 4 Fast production—better service.

Torture tests in this low temperature chest at G-M are only one of the ways G-M makes its servo motors *prove* themselves.

Each G-M servo motor must conform to military specifications *exactly*—for altitude, high and low temperatures, vibration and shock, humidity and salt spray.

And because G-M specializes in the manufacture of servo *motors* rather than servo *systems*, you can be *sure* each motor will have the optimum characteristics under this same condition for you.

**Write Now** for G-M charts, specifications and performance data. No obligation, of course.



# G-M Servo Motors

manufactured by the Components Division of  
**G-M LABORATORIES INC.**  
 4336 N. Knox Avenue • Chicago 41



# Waldes Truarc grip rings used on die-cast studs eliminate threading, tapping, other costly machining

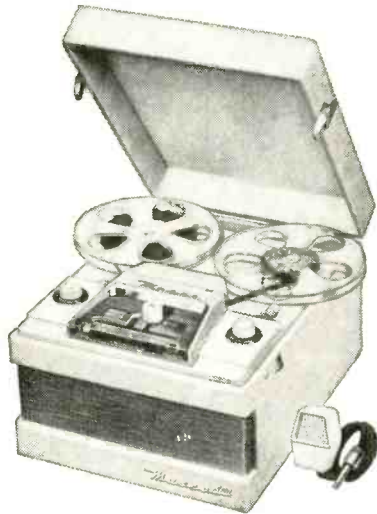

**Mark Simpson Manufacturing Co.,** Long Island City, N. Y., uses Waldes Truarc series 5555 Grip Rings to secure parts to studs of the zinc die-cast base of its "Masco 500" portable tape recorder.

The rings—which need no grooves—replace nuts, screws, cotter pins and other types of fastening devices which require threading, tapping, drilling and other expensive machining operations. Because a single cracked or broken stud would render the entire cast base useless—and with it, all assembly completed to that point—the rings also eliminate extremely costly rejects.

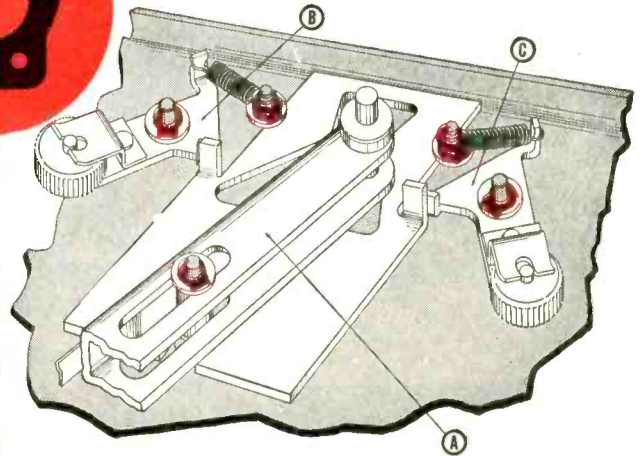

**Pivot Assembly** of shift lever (A) is secured by a single Waldes Truarc Grip Ring and washer. Because the washer must be installed over the shift level in a sliding fit, critical tolerances would have to be maintained if a screw or cotter pin were used. The Truarc Grip Ring eliminates that problem: it requires no groove and may be seated over the washer at any point on the stud, automatically compensating for accumulated tolerances in the parts. BRAKE ASSEMBLIES (B and C) use Grip Rings to secure the brake wheel and spring sub-assemblies. Here again problems of critical tolerances are avoided and expensive rejects eliminated.

Whatever you make, there's a Waldes Truarc Retaining Ring designed to improve your product... to save you material, machining and labor costs. They're quick and easy to assemble and disassemble, and they do a better job of holding parts together. Truarc rings are precision engineered and precision made, quality controlled from raw material to finished ring.

**36 functionally different types...** as many as 97

different sizes within a type... 5 metal specifications and 14 different finishes. Truarc rings are available from 90 stocking points throughout the U. S. A. and Canada.

**More than 30** engineering-minded factory representatives and 700 field men are available to you on call. Send us your blueprints today... let our Truarc engineers help you solve design, assembly and production problems... without obligation.

For precision internal grooving and undercutting... Waldes Truarc Grooving Tool!

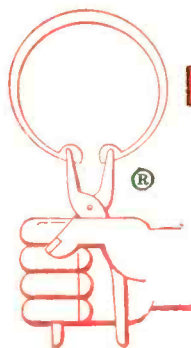

**WALDES**  
**TRUARC**®  
**RETAINING RINGS**

**WALDES KOHINOOR, INC.**  
47-16 AUSTEL PLACE, L. I. C. 1, N. Y.

Waldes Kohinoor, Inc., 47-16 Austel Place, L. I. C. 1, N.Y.  
Please send the new supplement No. 1 which brings Truarc Catalog RR 9-52 up to date.  
(Please print)

Name.....  
Title.....  
Company.....  
Business Address.....  
City..... Zone..... State.....

F-089

WALDES TRUARC Retaining Rings, Grooving Tools, Pliers, Applicators and Dispensers are protected by one or more of the following U. S. Patents: 2,382,948; 2,411,426; 2,411,761; 2,416,852; 2,420,921; 2,428,341; 2,439,785; 2,441,846; 2,455,165; 2,483,379; 2,483,380; 2,483,383; 2,487,802; 2,487,803; 2,491,306; 2,491,310; 2,509,081; 2,544,631; 2,546,616; 2,547,263; 2,558,704; 2,574,034; 2,577,319; 2,595,787, and other U. S. Patents pending. Equal patent protection established in foreign countries.

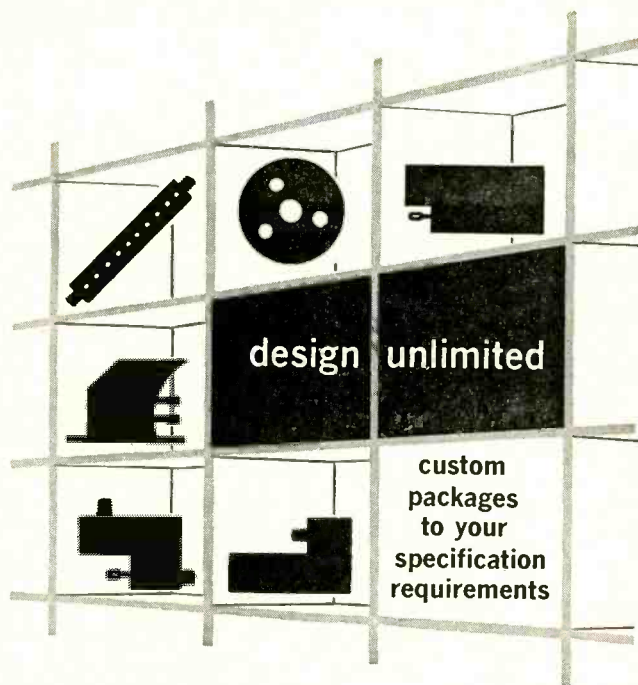
**edcor***hermetically sealed...  
sub-miniature and bathtub type*

## Paper-Foil Capacitors

Our specialty is the design and building of custom capacitors to specification . . . prompt delivery assured.

edcor engineers have an unlimited wealth of experience and electronic know-how in the design of precision capacitors. Utilizing advanced modern equipment, improved production techniques and quality control measures, to meet critical operational requirements . . . at savings to you.

**UNLIMITED SELECTION** . . . of tubular sizes, bathtub cases, mounting styles and circuit configurations are available in edcor PAPER-FOIL CAPACITORS, to MIL C-125A.

*highest  
reliability  
and quality  
control at  
low cost*

Our field Sales Engineers will welcome the opportunity to discuss your particular capacitor requirements. For the address of the office nearest you, or for complete technical data, write: Sales Engineering Dept., U.S. Electronics Development Corp., 1323 Airway, Glendale 1, California.

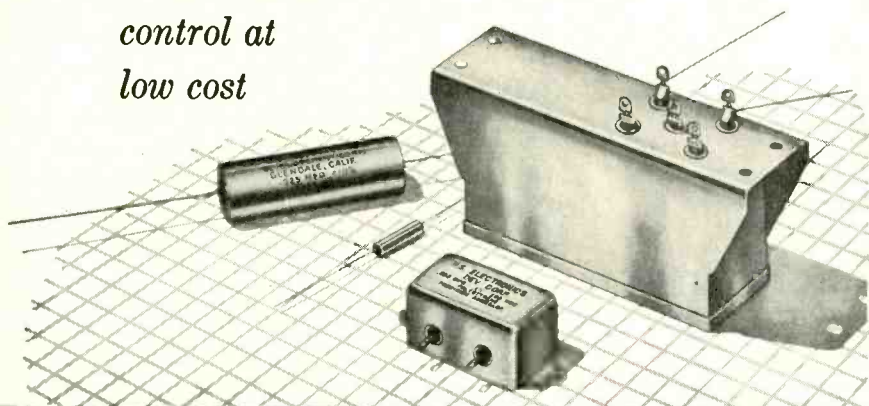
**U S edcor**

**U. S. Electronics Development Corporation**  
1323 Airway, Glendale 1, California

dipole exciter. Its gain is 23 db or better at 500 mc, with minimum side lobes and cross polarization of 20 db or better. It features low vswr at any frequency in the band accomplished through a unique readjusting balun and reflector assembly.

The antenna is of rugged, light-weight, all aluminum mesh construction, fully weatherized and corrosive resistant. It is available in both the 12-ft diameter model CF-121M, and a 14-ft diameter model CF-141M. **Circle 411** inside back cover.



### SILICON CRYSTALS

grown to required type

THERMOSEN, INC., 361 W. Main St., Stamford, Conn., announces the availability of oriented single crystal silicon ingots grown to customers' required type and resistivity. Crystals average 60 grams in weight, but smaller crystals can be supplied when desired.

Production is currently on a limited basis and priority will be given to customers requiring one or two crystals for research or small-scale production. Typical applications are rectifiers, transistors and infrared lenses. **Circle 412** inside back cover.

### CERAMIC SWITCH

with up to eight decks

THE DAVEN Co., Livingston, N. J. has available a new ceramic switch which can be ganged with up to eight decks. One, two or three poles per deck may be obtained as standard.

Occupying less than 1½ sq in. of panel space, this rugged miniature ceramic switch contains up to 18 positions on a single wafer. Solid silver-alloy contacts, rotors



# Forget the Amplifier

If your design utilizes an amplifier to boost a minute signal for relay operation — or, if you have 'shelved' some new product idea because the cost, space requirement and other drawbacks of amplifiers made the design impractical — *Sensitrol relays are for you.* For these tiny, ultra-sensitive relays, which operate direct on input signals as slight as *1 millivolt or 1/2 microampere*, and handle substantial wattage at *110 volts*, entirely replace amplifiers, vacuum tubes and auxiliary power supplies. They are available with single or double contacts, fixed or adjustable, manual or solenoid reset. For engineering assistance in adapting Sensitrol relays to present products, or new problems you have in mind, call your nearest Weston representative, or write for the Sensitrol bulletin B-25-B . . . *Weston Electrical Instrument Corporation, 614 Frelinghuysen Avenue, Newark 5, N. J.*

**Boost feeble  
input signals  
with compact**

*Sensitrol*<sup>®</sup>  
*relays*

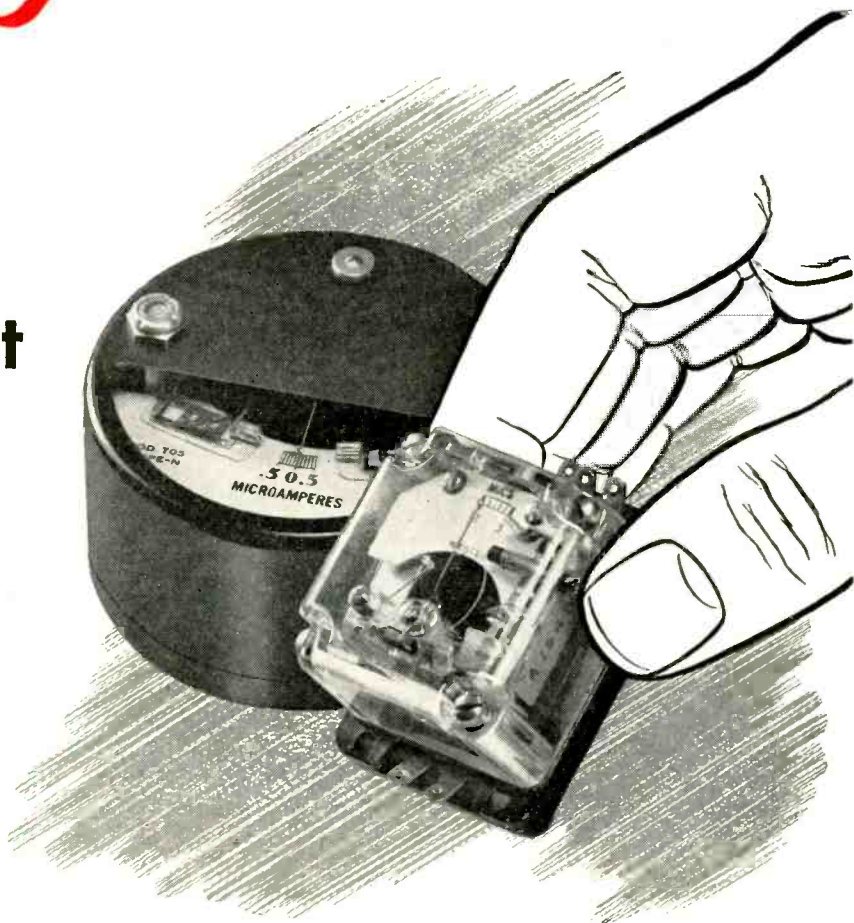

**WESTON**

**Instruments**



# ONE TEN



## The Magic Mirror One-Ten<sup>°</sup> Aluminized Picture Tube

The Magic Mirror **One-Ten<sup>°</sup>**, the brand-new 110° deflection picture tube, is designed by Tung-Sol to meet the most exacting specifications and performance requirements of manufacturers of portable and light-weight cabinet and table TV sets.

The Magic Mirror **One-Ten<sup>°</sup>** is being produced in types 17BZP4 and 21DAP4. The 17BZP4 is 12 9/16 inches long (three inches shorter than standard 90° tubes), possesses a 155 square-inch viewing area and weighs but 10 pounds. The 21DAP4 is 14 11/16 inches long, has a 262 square-inch area and weighs 20 pounds.

The Magic Mirror **One-Ten<sup>°</sup>** needs no ion-trap magnet. It is aluminized by the same unique method that has earned for all Tung-Sol picture tubes their reputation among set manufacturers for pictures of outstanding quality.

 **TUNG-SOL<sup>®</sup>**  
**ELECTRON TUBES**  
**SEMICONDUCTORS**

TUNG-SOL ELECTRIC INC., NEWARK 4, N. J.



# ONE TEN<sup>°</sup>

## Tung-Sol Horizontal, Vertical Deflection Tubes

Tung-Sol's complete complement of horizontal and vertical deflection tubes—engineered to the industry's most exacting standards—will insure maximum performance of the Magic Mirror **One-Ten<sup>°</sup>** and every other picture tube on the market, 110° or 90° deflection.



For additional information write Sales Dept., Tung-Sol Electric Inc., Newark 4, N. J. Sales Offices: Atlanta, Ga.; Columbus, Ohio; Culver City, Calif.; Dallas, Tex.; Denver, Colo.; Detroit, Mich.; Melrose Park, Ill.; Newark, N. J.; Seattle, Wash.

**TUNG-SOL<sup>®</sup>**

Circle 173 Readers Service Card

ELECTRONICS — August 1, 1957

NEW PRODUCTS

(continued)

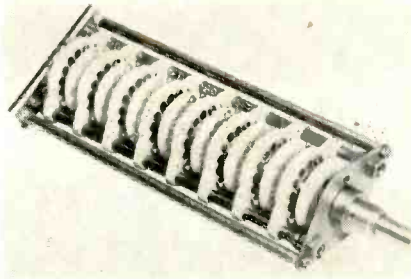

and slip rings provide low and uniform contact resistance. Ceramic parts are silicone impregnated to function under extreme humidity. Sturdy solder terminals are supplied for wiring. This miniature switch meets and exceeds the electrical and environmental requirements of MIL-Spec S-3786. Flashover voltage at 60 cycles is 1,000 v peak; current carrying capacity is 2 amperes.

These switches find a variety of applications on guided missiles, airborne radar equipment and portable and mobile ground equipment. **Circle 413 inside back cover.**

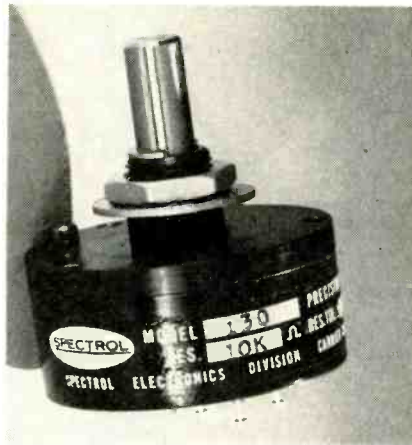

### SINGLE-TURN POT meets military specs

SPECTROL ELECTRONICS DIV. OF CARRIER CORP., 1704 South Del Mar Ave., San Gabriel, Calif., has announced a precision 1 $\frac{1}{8}$  in. diameter single-turn potentiometer, the model 130. It meets military specifications NAS-710 environmental humidity requirements, and will operate in a temperature range of -55 C to +85 C. Standard linearity tolerance is  $\pm 0.5$  percent, however special linearity tolerances are available upon request.

The unit has a standard resist-

# ONE TEN<sup>°</sup>

## Tung-Sol for Engineering Careers

Electron Optics, the particular field of engineering that played the most important part in the development of the Magic Mirror **One-Ten<sup>°</sup>**, is just one of many diversified engineering opportunities there are at Tung-Sol.

Our engineers handle interesting assignments in design, development, production, research and applications of electron tubes, semiconductors and current intermitters in addition to cathode ray tubes.

At Tung-Sol engineers are given definite responsibilities and the necessary latitude to allow their ability and initiative full rein. We know our engineers like this system of individual responsibility (and commensurate rewards) because the Tung-Sol *turnover rate is among the lowest in the industry!*

The steady growth of Tung-Sol is continually creating openings for additional engineers who are looking for more satisfying activities. If you feel you're still in a college lab after two to five years' experience as an electrical, electronic, mechanical or chemical engineer or as a metallurgist, physicist, or scientist and want to do something about it, contact us. Let's see what we have to offer each other. Write, wire or phone: David O. Bellar, Personnel Director, Tung-Sol Electric Inc., 200 Bloomfield Avenue, Bloomfield, N. J. Pilgrim 8-8700.

**TUNG-SOL<sup>®</sup>**

*matching antenna  
systems to RF  
equipment  
—with **TRANSCO**  
on the R&D*



Tailoring a complete antenna system to RF equipment can be easier, faster, more economical—if you put TRANSCO on the R&D. Ten years of RF work on military and commercial systems have produced a wealth of experience that you could be using. Extensive test facilities are your assurance of reliability.

*TRANSCO designs and manufactures:*

*antennas  
antenna couplers  
antenna mounts  
baluns & couplers  
coax switches  
filters  
multiplexers  
power splitters  
system control  
switches*

**TRANSCO PRODUCTS, INC.**

*The Finest in RF System Components*

12210 NEBRASKA AVENUE, LOS ANGELES 25, CALIFORNIA  
REPRESENTATIVES IN MAJOR AREAS

ance range from 10 ohms to 30,000 ohms, with a standard tolerance of  $\pm 3$  percent. Model 130 has a life exceeding 1,000,000 revolutions. Multiple taps can also be requested with as many as 11 additional taps being supplied to meet nearly all specific location requirements within 26 deg of each other, on the rear of the unit. Further information is available from the company. Circle 414 inside back cover.

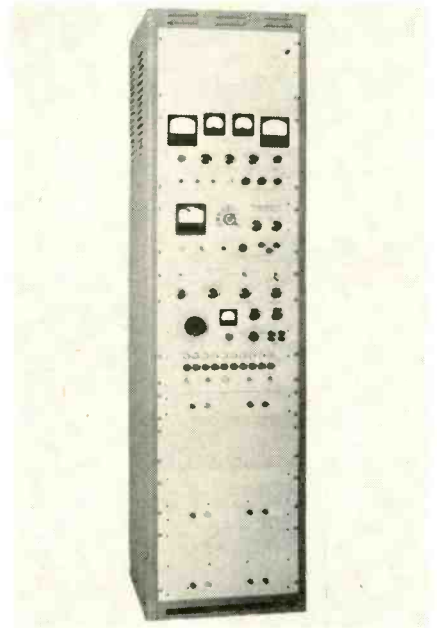

**TRANSISTOR ANALYZER**  
with extended power range

POLYPHASE INSTRUMENT Co., East Fourth St., Bridgeport, Pa. The extended power range of Polyphase model TA-13 transistor analyzer is sufficient to analyze the most important characteristics of all transistors. The collector sweep power supply, rated at 20 amperes and 150 v, is more than adequate for testing of transistors currently available. Transistors with power ratings ranging from 10 mw to 100 w may be tested. Tracing of seven characteristic family curves is presented on any conventional oscilloscope.

Electronically generated and swept, 10 constant-current input current steps are individually adjustable and metered to 50 ma per step or 450-ma total current. A built-in calibration axis generator



# Get ahead!

Check this unusual opportunity to advance... at Western Electric

Engineering careers don't get a chance to bog down at Western Electric... there's just too much going on to allow it.

In the course of their technical work, engineers participate in such broad managerial functions as production, merchandising, installation, and many others. What's more, we have a record of promotions from within. That's important when you realize that at least 8,000 of our people will be promoted to management jobs in the next 10 years.

Here you'd help engineer the manufacture, distribution or installation of equipment needed by the Bell System. Your responsibilities could involve radio relay equipment for TV and long distance calls, electronic switching, transistors, printed circuits, miniaturization, or automation. You'd work with top men in the communications field... in an atmosphere that's alive with the need for new products, new processes, new ideas. Your ideas would help answer the constant demand for more and better telephone service... help handle the constant flow of defense jobs that the government has asked us to take on over the years; like the Nike guided missile system, DEW Line and Sage, the continental defense system.

And you'd be given every encouragement to develop as rapidly as possible... our joint telephone-defense job demands it. A full-time Graduate Engineers Training Program is given new engineers during working hours to help them more easily assume a full engineering role. We also sponsor a tuition refund plan for out-of-hours study at nearby colleges.

So, check the openings for which you may be qualified (mechanical, electrical, chemical and civil engineers; physicists and mathematicians). Send resume of education and experience to Engineering Personnel, Room 1066, Western Electric Co., 195 Broadway, New York 7, N. Y.



## Western Electric

MANUFACTURING AND SUPPLY



UNIT OF THE BELL SYSTEM

Manufacturing plants in Chicago, Ill.; Kearny, N. J.; Baltimore, Md.; Indianapolis, Ind.; Allentown and Laureldale, Pa.; Burlington, Greensboro and Winston-Salem, N. C.; Buffalo, N. Y.; North Andover, Mass.; Lincoln and Omaha, Neb.; St. Paul and Duluth, Minn. Distributing Centers in 30 cities and Installation headquarters in 16 cities. Also, Teletype Corporation, Chicago 14, Illinois.

Get Precision at a New  
Low Price!

**GAMEWELL'S**

**G-20**  
SERIES

**PRECISION  
POTENTIOMETERS**

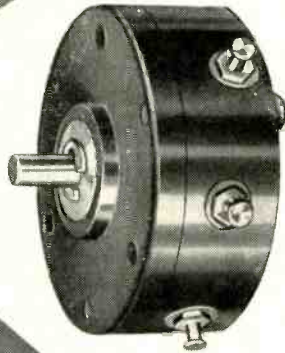

The New G-20 gives you a truly precision potentiometer with many characteristics found only in pots costing twice as much. Here are the outstanding features . . .

- Linearity is 0.5 or better
- Radial or Rear Extension Turret Terminals
- Non-metallic housing uses material of high dimensional stability that is inherently fungus-proof and moisture resistant
- Servo, Threaded-Bushing or Flange Type Mountings
- Power rating 1.5 watts at 65°C (derated to 0 at 150°C)

Gamewell gives you this high quality at low cost by new design techniques and high production methods.

See how many applications can use this new G-20. It is ideal where you require good precision at a bargain price for industrial and commercial apparatus. Gamewell is ready to supply these in quantity now.

**THE GAMEWELL COMPANY**  
NEWTON UPPER FALLS 64, MASS.



**PRECISION POTENTIOMETERS**

Manufacturers of Precision Electrical Equipment Since 1855

### Technical Data

Resistance, Max.	63,000 ohms $\pm 5\%$
Resistance, Min.	20 ohms $\pm 5\%$
Linearity Std.	$\pm 0.5$
Electrical Angle	$340^\circ \pm 3^\circ$
Max. No. of Turns	2100
Watts at 65°C	1.5
Torque Max.	1 oz. — in.
Max. Temperature	150°C
Weight	1¼ oz.

4-40 NC-2B 3-Holes  
Equally Spaced on .500 R.

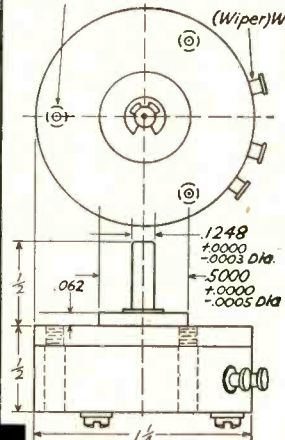

GA 6-8

NEW PRODUCTS

(continued)

is used for accurate oscilloscope calibration. Accurate meter measurement of small signal alpha and beta, d-c beta and d-c collector leakage current is conveniently performed. Circle 415 inside back cover.



### FLUTTER METER

features superior limiting

D & R, LTD., 402 E. Gutierrez St., Santa Barbara, Calif. Model FL-3D flutter and wow meter is designed to be used as a general purpose test instrument meeting the requirements for measuring flutter content in recording and reproducing systems as established by the IRE, ASA and SMPTE.

Superior limiting, extended bandwidth, selectable wow and flutter filters, and rms calibration are outstanding features. Full-scale sensitivities of 2.0 percent and 0.5 percent are available with accuracies better than 10 percent. An output terminal is included to provide a d-c to 250 cps signal for graphic recording purposes. A regulated power supply insures stable operation of internal 3,000-cps carrier oscillator over wide excursions of the input line voltage. The FL-3D measures 7 in. by 12 in. by 6 in. and weighs only 10½ lb. Circle 416 inside back cover.

### VOLTAGE REGULATORS

corona type instruments

THE VICTOREEN INSTRUMENT CO., 5806 Hough Ave., Cleveland 3, Ohio, announces the development of corona type regulators with current ratings up to 4 ma. They are produced for MIL and other



The new  
**DYNASERT**

**#3 Component  
Inserting  
Machine**

- ☆ Takes axial lead components in broad range of sizes and shapes
- ☆ Handles bent or off-center leads
- ☆ Cuts assembly time and costs — improves reliability

Machine cuts component leads, forms them into a staple shape, inserts them into holes in your wiring boards and clinches in one operation. Up to 700 insertions per hour can be made on average size board.

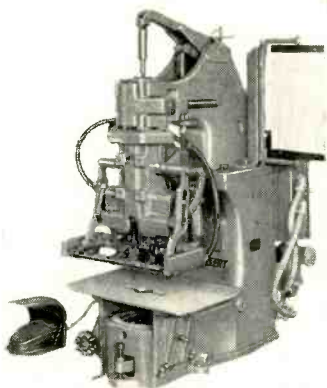

Here's a brand new machine for inserting components in printed wiring boards. It's so advanced in adaptability and performance reliability that it gives new meaning to mechanized assembly.

This machine eliminates normal requirements for straight or centered

leads, special packaging or preparation. It is economical for use on short runs; new set-ups are quickly made by simple adjustments or slip-in tooling.

Available either for individual bench operation or as a unit in fully automatic conveyORIZED assembly lines. For full information write:

INDUSTRIAL SALES DIVISION

**United**

**SHOE MACHINERY CORPORATION**

140 FEDERAL STREET, BOSTON, MASS.

PRODUCTION EQUIPMENT FOR ELECTRONICS

# A **NEW** look at h-f time-rate indicators

**look new** **Hetrodyne Conversion?**  
In one package — to 250 mc! Use our Model 510 with 501A.

**look new** **Long-Term Reliability?**  
A new standard in cool operation.

**look new** **Period Averaging?**  
10, 100 and 1000 periods built in (no plug-in).

**look new** **10 mc Plug-In Decade?**  
An LFE exclusive — no meters!

**look new** **Ratio Measurements?**  
The only 10mc TRI that makes them.

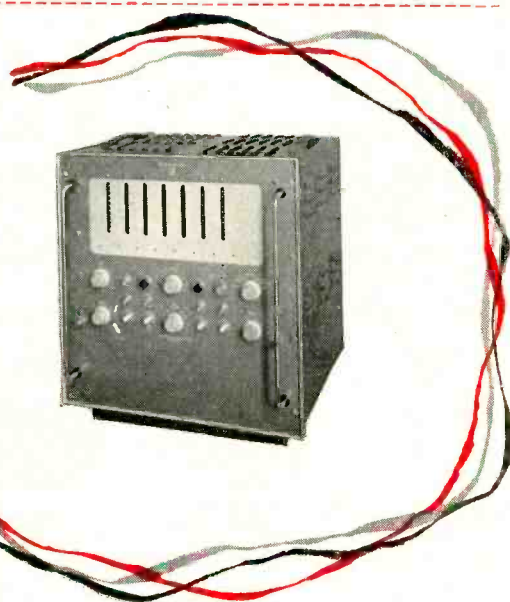

501A utilizes the inherent plus or minus one count accuracy of digital scalars . . . both for counting and for interval determination . . . measures rate or period of recurrent events, sine waves or pulses, periodic or random, with unmatched accuracy at rates up to 10mc/sec.



## LABORATORY FOR ELECTRONICS, INC.

75 PITTS ST. • BOSTON, MASS.

Inquiries may be made to the main office or at Booths 2806, 2807, WESCON Show, Kittleson Co., West Coast Technical Representative.

applications in T6½ and T9 envelopes in voltage ranges below 3,500 v.

This simple form of high voltage regulation can be used in many applications formerly requiring the more complex multi-tube systems. Suggested applications for high current corona type voltage regulators include klystron power supply, high beam current synchroscopes, laboratory oscilloscopes, radar display units and magnetron oscillators. Circle 417 inside back cover.



## R-F PREAMPLIFIER high-gain type

RADIATION, INC., P. O. Box 37, Melbourne, Florida. This preamplifier combines extremely high gain with a low noise figure and relatively wide bandwidth. The model 1 provides a gain of 35 db at band center and the model 2, 50 db, both with a maximum noise figure of 3.5 db. Frequency response is within 3 db over the band of 215-247 mc. The unit occupies a volume of ½ cu ft and weighs less than 3½ lb. Circle 418 inside back cover.

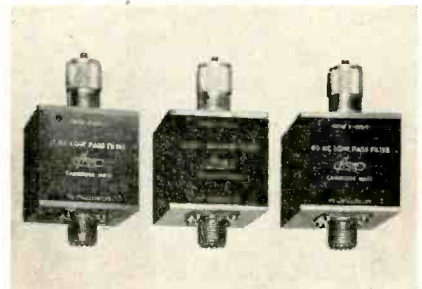

## LOW-PASS FILTERS remove undesired h-f signals

FLOW CORPORATION, 85 Mystic St., Arlington 74, Mass., announces a





# Silicone Dielectrics

ELECTRICAL AND ELECTRONIC NEWS No. 13

## Reliability of Snark Instruments Assured with Silicone Rubber

Engineers at Northrop Aviation take no chances on the performance of intricate high impedance circuits in the "Snark" guided missile, the F-89 Interceptor and other Northrop projects. They virtually "seal in" top performance by completely encapsulating the brains of these units in Silastic\* RTV.

A new, easy-to-apply silicone dielectric that vulcanizes into a rubbery solid at room temperatures, Silastic RTV provides positive protection for even the most delicate electronic components. All panels containing resistors, capacitors, transistors and other recording and transmitting gear are embedded in this Dow Corning silicone rubber. According to Northrop engineers, a single coating—

- provides an effective cushion against vibration
- assures maximum moisture resistance
- improves electrical properties, especially surface resistivity
- protects assemblies against rough handling
- may be applied with a caulking gun



Another important advantage of using Silastic RTV in this application is the ease of inspecting or replacing individual components after assembly. The silicone rubber "skin" is simply slit open to expose the component. Such openings are easily patched with more Silastic RTV.

Silastic RTV ranges from a heavy putty to a fluid-like consistency. It attains optimum physical and dielectric properties in 4 to 7 days. **No. 51**

\*T. M. REG. U. S. PAT. OFF.

## Westinghouse Introduces Silicone Insulated D-C Motors

While most leading manufacturers of electrical equipment build silicone insulated units for special purposes, now for the first time Westinghouse's new Life Line "H" series offers the advantages of silicone insulation in standard "off the shelf" d-c motors and generators.

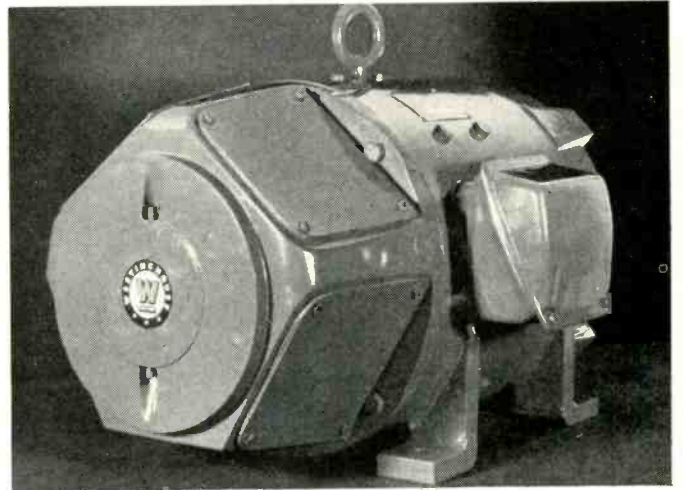

Dow Corning silicones have been used in combining a high temperature insulating system with complements of copper and iron equal to those used in conventional Class B machines. As a result, these new motors and generators rated at Class B temperatures have at least 10 times longer insulation life.

In addition, Dow Corning silicones help provide extra protection against emergency overloads and abnormal ambients to reduce

motor maintenance. Insulation is no longer a limiting factor to motor life. Already in production, the new dc motors span ratings from 1 to 150 hp; the dc generators are rated from 3/4 to 100 kilowatts.

Life Line "H" equipment is designed to be especially useful for automated processing where insulation failure in one unit may shut down an entire assembly line throwing production schedules and costs way out of line.

The extra overload capacity provided by the silicone insulation system makes these motors ideal for conveyor, pump, blower and processing motors in mines; for drive motors in the glass, machine tool, paper and metals industries; for conveyor drive motors in material handling and many other processing industries. **No. 50**

## Silicone Glass Coil Insulators Reduce Small Motor Assembly Costs

By insulating the coils of their 1/8 hp, 14,000 rpm afterburner ignition actuator motors with silicone-glass laminates, Lear, Inc., have cut costs a substantial \$1.50 per unit

Located next to jet engines where ambient temperatures soar to 400 F and higher, these motors have always been silicone protected. Lear originally tape-wrapped the coils by hand, but they recently eliminated this time-consuming job by switching to pre-formed glass laminates bonded with a Dow Corning silicone resin.

By reducing assembly time to an absolute minimum, the laminated insulators save Lear \$1.50 per motor while still providing the maximum in insulating efficiency. The coil insulators are pre-formed in two sections by Stevens Products of East Orange, New Jersey. **No. 52**

**Send Coupon for More Information**

**DOW CORNING CORPORATION - Dept. 4820**

Midland, Michigan

Please send me **50** **51** **52**

NAME \_\_\_\_\_

TITLE \_\_\_\_\_

COMPANY \_\_\_\_\_

STREET \_\_\_\_\_

CITY \_\_\_\_\_ ZONE \_\_\_\_\_ STATE \_\_\_\_\_

ATLANTA • BOSTON • CHICAGO • CLEVELAND • DALLAS • DETROIT • LOS ANGELES • NEW YORK • WASHINGTON, D. C.  
Canada: Dow Corning Silicones Ltd., Toronto; Great Britain: Midland Silicones Ltd., London; France: St. Gobain, Paris

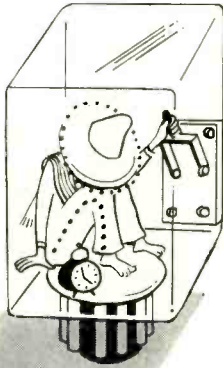
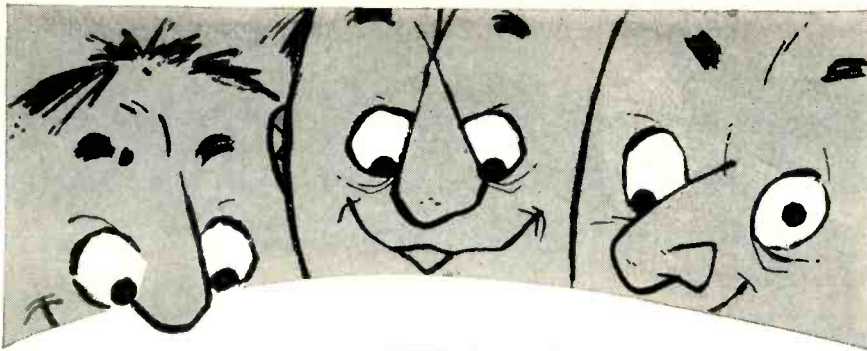

## PERSPICUOUS SWITCH

Is it enough that a relay works? Not since we discovered the omission of a singularly vital instituent. To be a first-rate success today, a relay must reveal what it is doing every minute. With this in mind Sigma has developed a Radically New type of fully enclosed relay (see above) in which all moving parts can be seen moving while it is in operation. Although unsuitable for military use, this relay has already attracted considerable interest in certain quarters.\* Technical features include:

spark gap reference scale for quick visual juice estimations; fail-safe alarm; Manuel reset; contact unwelding mechanism and pit remover; double-pole, doubtful-throw contacts; ampere turn-signals. Continued observation of the operation of this new Sigma relay will pave the way for even greater discoveries and developments in the field, and permit other things. Basically, that is why none are presently for sale; all are in use by NASAW members who work at Sigma.

In their off moments (coffee break, luncheon bridge game, etc.) sensible members of this group\* worked on another relay which is not as spectacular, but is available. A close watch of the Series 42 has shown that this DPDT relay: operates on less than 0.2 watt (DC), less than 0.5 volt-ampere (AC); doesn't chatter, buzz or snore; uses less power (AC version) than — and is interchangeable with — most competitive types; and is rated to switch 5 amperes. The DC version could be used as the output

relay in such things as machinery control panels, automatic scales, circuits driven by Sigma Magnetic Amplifiers, and other domestic devices not requiring switching of the saludos amigos variety. It has no spark gap scale, but in normal use this relay will operate many millions of times. More information is contained in a bulletin, available on request.



Sigma Type 42RO Relay; transparent plastic dust cover.

\*NORTH AMERICAN SOCIETY OF ARMATURE WATCHERS

# SIGMA

SIGMA INSTRUMENTS, INC.  
62 Pearl Street, So. Braintree 85, Mass.

new series of audio low-pass filters for use in any system whose a-c resolution in the a-f range suffers from stray noise at frequencies above the range of interest.

These new series F sharp-cutoff low pass filters remove undesired h-f signals such as amplifier noise in the amplified output signals from hot wire anemometers, strain gages, vibration pickups, acoustic pickups and the like.

Standard values available from stock are 7, 20 and 40-kc cutoff. Attenuation is zero at low frequency, 1 db at cutoff frequency and 12 db per octave above cutoff. Connectors are standard AN PL-259 coaxial input and SO-239 coaxial output. Input impedance is 500 ohms; output impedance, 4,000 ohms. Size is 2 by 2 by 2 in. Shells are extruded aluminum, distinctively color coded and marked. **Circle 419 inside back cover.**

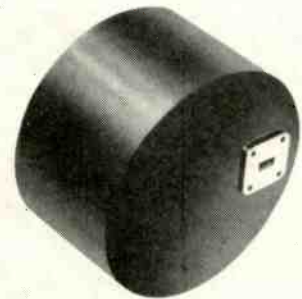

## MINIATURE ISOLATOR for Ka-band use

AIRTRON, INC., 1101 W. Elizabeth Ave., Linden, N. J., announces a new 100-kw resonant absorption Ka-band miniature isolator weighing less than 3 lb. Designed to operate over a frequency range of 34.5 to 35.9 kmc, it insures optimum magnetron spectrum and power output by furnishing isolation between magnetron and r-f energy reflected from line mismatches.

Because of its extremely compact shape, the isolator affords retrofitting easily and simply; consequently, redesigning of existing systems is simplified or unnecessary.

Since the ferrite is mounted di-



# FIRST IN SERVICE



## CNI

### ELECTRONICS PACKAGE NOW IN FULL PRODUCTION

The AN/ASQ-17 CNI package, developed and built by Packard Bell Electronics, marks the first successful integration of communications, navigation and identification in one compact unit. It has been accepted for service use by the U.S. Navy in the Douglas A4D "Skyhawk" and the Chance-Vought F8U "Crusader." It has been in quantity production for several months. Hundreds are now in operation.

#### ENGINEERING BEYOND THE EXPECTED

Mutual interference between IFF and UHF is normally inevitable, even when the units are encased separately and spaced several feet apart. In the AN/ASQ-17 these two units are packaged together, *a fraction of an inch* apart. Yet in official trials *mutual interference was not noticeable or measurable*. This achievement "beyond the expected" resulted from coordinated efforts of Douglas, Chance-Vought and Packard Bell Electronics engineers.

*AN/ASQ-17 will be featured at Booths 609-610, WESCON, San Francisco Cow Palace, Aug. 20-23.*



#### PACKARD BELL ELECTRONICS TECHNICAL PRODUCTS DIVISION

12333 W. Olympic Boulevard  
Los Angeles 64, Calif., BRadshaw 2-2171

# A New Concept of TIME . . .



INDUCTOR MOTOR



REVERSIBLE MOTOR



CLUTCH MOTOR

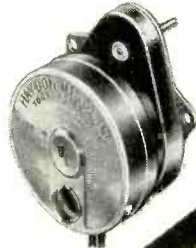

HYSTERESIS MOTOR



DIRECT CURRENT MOTOR



400 CPS MOTOR

. . . this Complete  
NEW Line of

## HAYDON\* TIMING MOTORS

Here is a complete line of timing motors that includes the right choice for every APPLICATION . . . entirely re-designed for finer performance. Features include: slower basic rotor speed (450 rpm), controlled lubrication, total enclosure, smaller size, superior accuracy, quieter operation and longer life.

**HYSTERESIS** . . . the ideal general-purpose motor.

**INDUCTOR** . . . extra torque (30 ounce inches) for display and other heavy-duty jobs.

**CLUTCH** . . . allows automatic re-setting without external clutches.

**REVERSIBLE** . . . a hysteresis type with 2 coils, each producing opposite rotation.

**DIRECT CURRENT** . . . a permanent magnet type for 6 to 32 volts.

**400 CPS** . . . miniature and heavy-duty models for airborne instrumentation.

FOR COMPLETE INFORMATION, write today for new catalog . . . or contact the HAYDON Field Engineer nearest you.

\*Trademark Reg. U.S. Patent Office

**HAYDON**  
AT TORRINGTON

A SUBSIDIARY OF GENERAL TIME CORPORATION

HEADQUARTERS FOR  
**TIMING**

**HAYDON Manufacturing Company, Inc.**  
2432-C ELM STREET, TORRINGTON, CONN.

rectly on the waveguide wall, heat is conducted away from it quite rapidly, allowing operation at high power levels without forced air cooling.

Optimum electrical characteristics include an isolation of 20 db minimum and an insertion loss of 1 db maximum. It operates over a temperature range of  $-55^{\circ}\text{C}$  to  $+100^{\circ}\text{C}$ . These operating characteristics are guaranteed under vibration specification MIL-E-5272A. Circle 420 inside back cover.

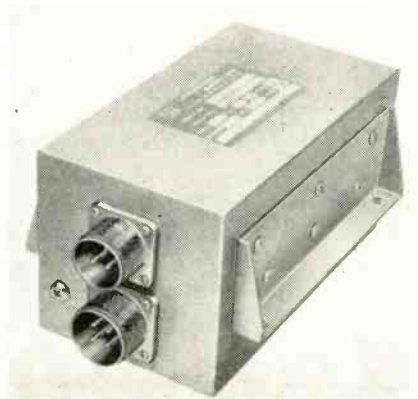

### POWER SUPPLIES

low voltage a-c, d-c type

ENGINEERED MAGNETICS DIVISION, Gulton Industries, Inc., Metuchen, N. J., announces a new line of Glennite low voltage a-c, d-c power supplies. Engineered to deliver precise plate voltages to aircraft electronic systems, the Glennite telemeter and strain gage power supplies are designed for 400-cycle operation, but are also available for 60-cycle circuits. Hermetically sealed, the tubeless power supplies have no moving parts.

Characteristics include a regulation of  $\pm 0.2$  percent, ripple of 1 percent rms, recovery time of 0.5 sec and a variety of outputs. These power supplies will retain accuracy under extreme airborne conditions of shock and vibration. Circle 421 inside back cover.

### SCREEN RESIST

for printed circuits

TECHNIQUES INC., 52 Jackson Ave., Hackensack, N. J., has announced



# Coffee-break Reading —



## REPRESENTATIVE FIELDS OF APPLICATION

Aviation, Navigation  
Ordnance, Ballistics  
High-speed Photography  
Viscosity Measurement  
Fluid Flow  
Nuclear Physics  
Telemetry  
Chemical Reaction  
Radiation Counting  
Computers  
Facsimile  
Fire Control  
Accurate Speed Control  
School and Indl. Research Labs.

**I**F you are responsible for (or are engaged in) the design, development, purchase or production of systems requiring precision timing, you realize the distinct advantage of knowing about the companies from which you buy. The background, experience, reputation of these suppliers and the application of their products can, as you know, act as a valuable guide in saving time and money, — not to say the avoidance of regret and disappointment.

- So, over your coffee cup, know ye that: —
- Our products consist basically of frequency standards and precision, electronic forks, (50 to 3000 cycles, accuracy to 1 part in 100,000 or better if required). These are available separately for integration with units of your own manufacture or as parts of instruments made by us.
- Several of our executives have engaged in the engineering of these frequency standards and precision forks for more than 20 years; a few more are at the 15-year mark. During this time we have learned much regarding the subtle idiosyncracies of materials and the mischievous capers of delicate processes. Each of our completed production units undergo 85 measurements. A single transistorized standard contains copper, steel, nylon, silicone rubber, glass, carbon, teflon wire, mylar capacitors, silicon diodes and a fork alloy containing 15 elements. So what? Accuracy, dependability, stability . . . superiority.
- In miniaturization, our staff has produced units which, in a 5-ounce, 6-cubic inch volume have proved more rugged and possess efficiency superior to 60-pound, 3-cubic foot units in general use some years ago.
- Our company has been in the frequency standard business for 20 years. Instruments of our manufacture have met the rigid inspection and exacting tests imposed by governments, the armed forces and industry for widely varied, high-precision timing applications. Continuing reorders and our consequent growth attest the satisfaction of our products.

**American Time Products, Inc.**  
580 Fifth Avenue, New York 36, N.Y.

## LAPP STAND-OFF INSULATORS FOR MODERATE OR HEAVY DUTY

For years, Lapp has been a major supplier of stand-off insulators to radio, television and electronics industries. Wide knowledge of electrical porcelain application, combined with excellent engineering and production facilities, makes possible design and manufacture of units to almost any performance specification. The insulators shown on this page are representative of catalog items—usually available from stock—and certain examples of special stand-offs. The ceramic used is the same porcelain and steatite of which larger Lapp radio and transmission insulators are made. Hardware is brass or bronze; brush nickel plating is standard.

Write for Bulletin 301 with complete description and specification data. Lapp Insulator Co., Inc., Radio Specialties Division, 133 Sumner St., Le Roy, N. Y.



Supracote Blacktop No. 3. This material is a superior screen resist formulation for printed circuits. It is designed to withstand the action of alkaline cleaning and plating baths without lifting, pitting or undercutting. Excellent results are obtained either with ferric chloride or sulfuric chromic etchants. Sharpness and detail of pattern laid down compare extremely favorably with direct photographic process. Circle 422 inside back cover.



### MEGOHMMETER both resistance, conductance

THE HERMAN H. STICHT Co., INC., 27 Park Place, New York 7, N. Y. Model 35A high resistance MYRIA megohmmeter is of British manufacture. It not only covers a very wide range of resistances from 50,000 ohms to 200,000 megohms over 10 ranges, with 2 fixed test potentials, but it has a scale reading also in conductance. The instrument is calibrated in conductance as well as in resistance.

The instrument is 13½ in. by 11 in. by 8½ in., weighs only 22 lb and is equally suitable for use in workshop, field, or laboratory. Circle 423 inside back cover.

### RELAY for military and industry

RADIO CORP. OF AMERICA, Camden, N. J., recently developed type 204W1 high-temperature airborne-electronic relay. It features an active getter for absorption of residual gas and organic vapors. Inclusion of the getter assures dependable operation over an ambient range of -65 to +125 C,



\* now in your hands . . .

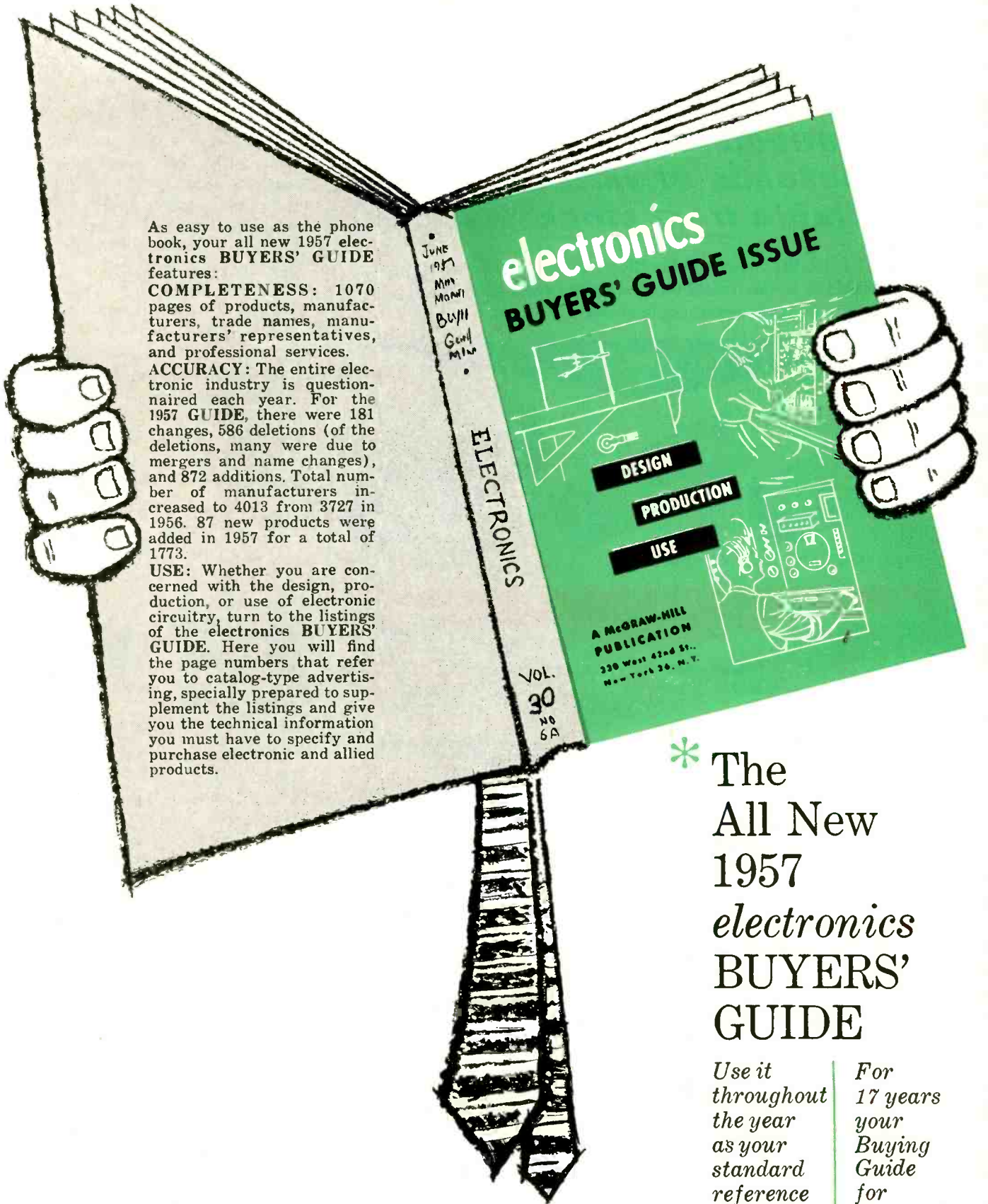

As easy to use as the phone book, your all new 1957 electronics **BUYERS' GUIDE** features:

**COMPLETENESS:** 1070 pages of products, manufacturers, trade names, manufacturers' representatives, and professional services.

**ACCURACY:** The entire electronic industry is questioned each year. For the 1957 **GUIDE**, there were 181 changes, 586 deletions (of the deletions, many were due to mergers and name changes), and 872 additions. Total number of manufacturers increased to 4013 from 3727 in 1956. 87 new products were added in 1957 for a total of 1773.

**USE:** Whether you are concerned with the design, production, or use of electronic circuitry, turn to the listings of the electronics **BUYERS' GUIDE**. Here you will find the page numbers that refer you to catalog-type advertising, specially prepared to supplement the listings and give you the technical information you must have to specify and purchase electronic and allied products.

JUNE 1957  
MAY  
MAY  
BUYER  
GOLF  
MAY

ELECTRONICS

electronics  
BUYERS' GUIDE ISSUE

DESIGN  
PRODUCTION  
USE

A MCGRAW-HILL  
PUBLICATION  
330 West 42nd St.,  
New York 36, N. Y.

VOL.  
30  
NO  
6A

\* The  
All New  
1957  
electronics  
BUYERS'  
GUIDE

Use it  
throughout  
the year  
as your  
standard  
reference  
source

For  
17 years  
your  
Buying  
Guide  
for  
electronics

electronics A McGraw-Hill Publication 330 West 42nd Street New York 36, N.Y. ABC ABC

# BOURNS

## TRIMPOT®

**and related sub-miniature potentiometers**  
**-thousands of variations**  
**available from stock**

SELECT from the many combinations shown below. Any choice is available in a wide selection of standard resistance values... for military or commercial applications.

these TERMINALS:

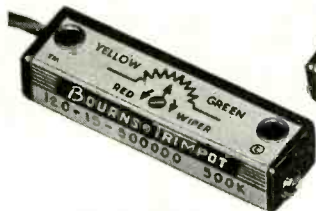

WIRE LEADS

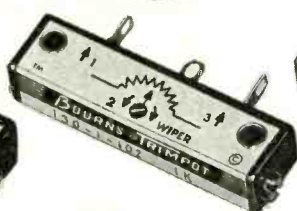

SOLDER LUGS

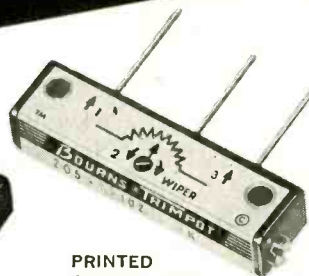

PRINTED CIRCUIT PINS

in these TYPES:

(select one or any combination)

HIGH OR MEDIUM TEMPERATURE

HUMIDITY PROOF

HIGH RESISTANCE

DUAL OUTPUT

VARIABLE RESISTOR

with these RESISTANCE ELEMENTS:

WIREWOUND



CARBON



ALL UNITS FEATURE sub-miniature size... space-saving configuration... self-locking shaft with 25-turn screwdriver adjustment... excellent acceleration, vibration and shock characteristics... mounting individually or in stacked assemblies, with standard 2-56 screws.

Over 50,000 units in stock. Send for complete catalog on the TRIMPOT and related potentiometers.

PLUS THE NEW TRIMPOT JR.



Micro-miniature size  $\frac{3}{16}$ "x $\frac{5}{16}$ "x1"  
 2.0-watt power rating. Humidity proof.  
 175°C. max. operating temperature.

CORP. BL. PATENTS ISSUED AND PENDING



**BOURNS LABORATORIES, INC.**

General Offices: 6135 Magnolia Ave., Riverside, Calif.  
 Plants: Riverside, California—Ames, Iowa

TRIMPOT • LINEAR MOTION POTENTIOMETERS • PRESSURE TRANSDUCERS AND ACCELEROMETERS

NEW PRODUCTS

(continued)

and under low-current, low-voltage as well as full load conditions.

A 6pdt, miniaturized-type, hermetically sealed relay, the 204W1 utilizes palladium contacts and is compactly constructed to meet the electrical and mechanical requirements of U.S. military relay specification MIL-R-5757. This rugged relay is built to withstand severe conditions of shock, vibration, humidity and altitude.

Design features include a unique one-piece extruded can with two integral mounting flanges safeguarding against h-f vibration, shock and salt spray. In production, the 204W1 is evacuated, filled with gas, and hermetically sealed to prevent coil and contact damage from dust, moisture and corrosion.

Rigorous testing throughout the entire manufacturing process insures peak operating performance. Overall height is  $1\frac{1}{2}$  in. Its diameter is  $1\frac{1}{8}$  in. and it weighs less than 3 oz. Circle 424 inside back cover.



### CONNECTORS

miniature and subminiature

KINGS ELECTRONICS Co., INC., 40 Marbledale Road, Tuckahoe, N. Y., introduces the KM series of small, lightweight miniature and sub-miniature connectors. This series is used with RG-59/U, RG-62/U and RG-71/U cables. These connectors have a peak voltage of 500 v and operating temperatures from 350 to 450 F. From left to right are: plug (KM-51-01), tee adapter (KM-91-02), panel jack (KM-11-01) and angle plug (KM-51-02). Circle 425 inside back cover.

### JACK PANEL

double row type

AUDIO DEVELOPMENT Co., 2833 13th Ave. South, Minneapolis 7, Minn., has available the new PJ-340 double row jack panel. The new





**WESTINGHOUSE SILICON RECTIFIER WN-5082**, with maximum peak inverse voltage ratings of 50-400 v. (300 to 5000 amperes in bridge assemblies.)

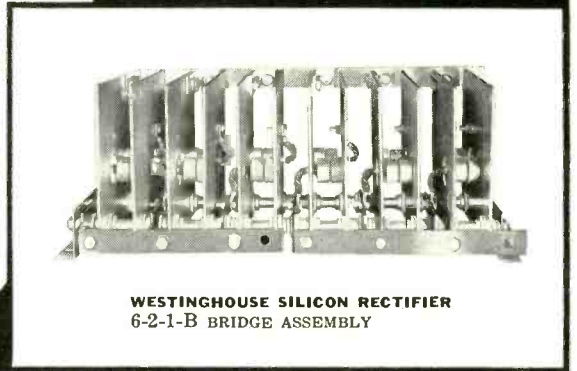
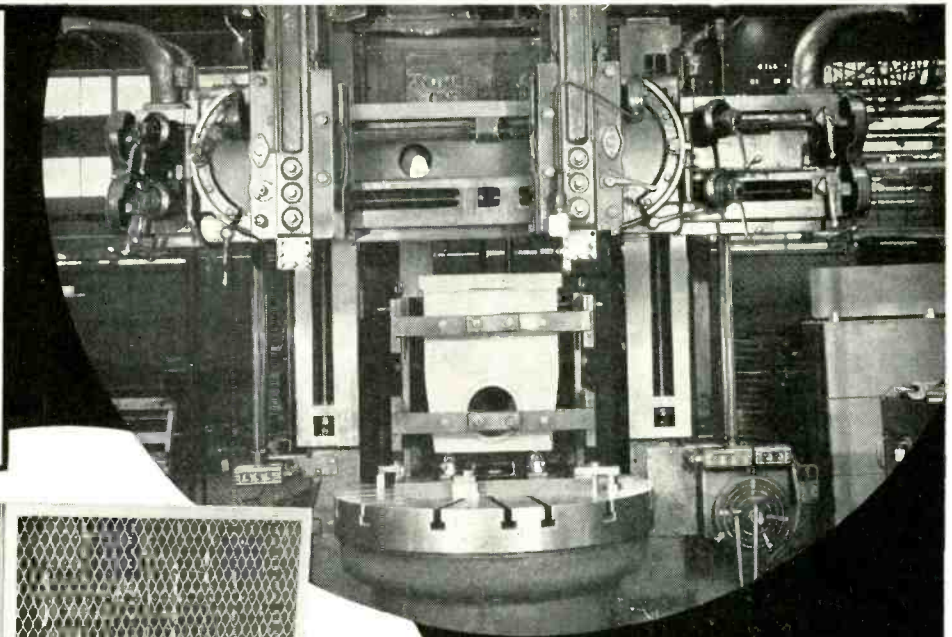

**WESTINGHOUSE SILICON RECTIFIER 6-2-1-B BRIDGE ASSEMBLY**

# Westinghouse SILICON<sup>(Si)</sup> RECTIFIERS put more muscle in DC power converter!

Successfully proven in rigorous welding, aircraft and guided missile applications, Westinghouse Silicon Power Rectifiers offer many advantages for power supplies.

Used in the Westinghouse 50KW Power Converter to drive the boring mill above, the WN-5082 bridge assembly supplies greater power and higher efficiency in less space. The 3-phase 60-cycle 440 v. power supply operates with a full load efficiency of 90% and an even higher half load efficiency. Regulation is approximately 8% from no load to full load with a Power Factor of 96 to 97.

Especially rugged for varying duty cycles, the WN-5082 withstands heavy loads of constant on-off operation, high-voltage transients, alternate heating and cooling.

**YOU CAN BE SURE...IF IT'S**

# Westinghouse

Westinghouse can supply single diodes or complete bridge assemblies built to your specifications. For full information on how Westinghouse Silicon Rectifiers can bring new efficiency and economy to your applications, mail the coupon today.

**WESTINGHOUSE ELECTRIC CORPORATION**  
P. O. Box 868, Pittsburgh 30, Pa.

Please send me data on the new Westinghouse WN-5082 Silicon Rectifier.

Please send me data on other Westinghouse Silicon Rectifiers. (Describe types or applications) \_\_\_\_\_

NAME \_\_\_\_\_

TITLE \_\_\_\_\_ FIRM \_\_\_\_\_

ADDRESS \_\_\_\_\_

CITY \_\_\_\_\_ ZONE \_\_\_\_\_ STATE \_\_\_\_\_

Reliable and Compact!  
FOR MISSILE AND AIRCRAFT SERVO APPLICATIONS

# TRANSI-MAG<sup>®</sup>

3.5 WATT

## SERVO AMPLIFIER



MODEL  
TMA-W40501-KX

**Note:** Unit will be inoperative when external connection is open. Exact resistor value for other motors should be chosen so that the D.C. voltage across the resistor is approximately 18 volts.

- by **MA**
- TRANSISTOR-MAGNETIC
  - HIGH GAIN
  - 1/2 CYCLE RESPONSE
  - MINIATURIZED
  - —55°C to 100°C

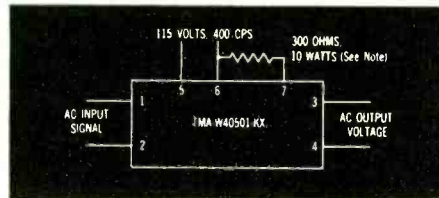
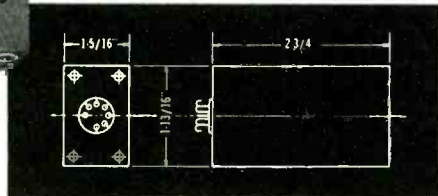

Designed for service where available space is at a minimum. Features high gain, fast response and drift-free characteristics. Completely self-contained, unit requires no power supply, demodulation or preamplifier; a complete high performance servo loop is obtained without added amplifying elements. These characteristics are achieved by employment of a stabilized silicon transistor preamplifier with a high speed, fast response miniaturized magnetic amplifier output stage. For complete data, request Bulletin 100-106.

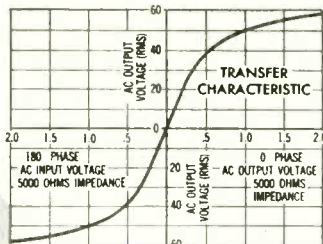

### General Specifications:

Supply Voltage \_\_\_\_\_ 115V  
Supply Frequency \_\_\_\_\_ 400 cps  
Rated Max. Power Output \_\_\_\_\_ 3.5 watts  
Typical Motor Load \_\_\_\_\_ Bu. ORD MK 14  
or Kearfott R119 Servomotor  
Output Voltage \_\_\_\_\_ 0-57.5 Volts  
Load Impedance \_\_\_\_\_ 940 ohms  
Input Impedance \_\_\_\_\_ 5000 ohms  
Sensitivity \_\_\_\_\_ See Characteristic Curve  
Zero Drift \_\_\_\_\_ Less than 1%  
Weight \_\_\_\_\_ 7 3/4 ounces

## MAGNETIC AMPLIFIERS • INC

632 TINTON AVENUE, NEW YORK 55, N.Y.—CYpress 2-6610  
West Coast Division

136 WASHINGTON ST., EL SEGUNDO, CAL.—EAsgate 2-2056

Other MA Inc. Products include: MAGNETIC SERVO AMPLIFIERS, MAGNE-SPEED<sup>®</sup> DRIVES, ANALOG COMPUTERS, PHOTOELECTRIC CONTROLS, REGULATED POWER SUPPLIES & CUSTOM ENGINEERED AUTOMATIC CONTROL EQUIPMENT

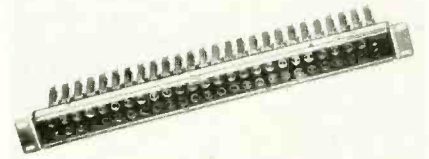

panel provides for 52 jacks mounted on 5/8 in. centers. It is constructed of molded black phenolic plastic reinforced with steel for maximum rigidity. It is 1 3/4 in. wide and fits a standard 19 in. relay rack.

The PJ-340 comes complete with 52 ADC type PJ-318 normally closed circuit jacks. Mounting brackets, designation strips, and jacks are plated to withstand a 50 hr salt spray test.

This jack panel is equivalent to the Western Electric 230 A. It is also available without jacks as ADC type PJ-30. Circle 426 inside back cover.

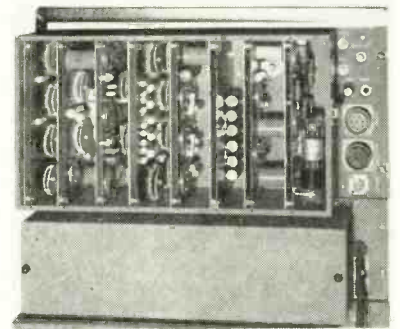

### SSB TRANSCEIVER

completely transistorized

ERCO RADIO LABORATORIES, INC., Garden City, New York. Type 464-TR carrier frequency ssb transceiver will provide reliable voice communication channels over existing telephone or power lines where additional talking facilities are required. It can be used on any frequency between 5 kc and 200 kc where the total attenuation does not exceed 80 db with each voice channel occupying a bandwidth of 3,000 cps.

Plug-in modular construction together with printed circuitry is employed and the complete trans-



**AVOID  
PROTOTYPE DELAYS!  
SPECTROL  
takes only 10 DAYS!**



**MON 1** Spectrol's prototype facility goes into high gear the moment your order is received.



**TUES 2** Design experts analyze the special features of your potentiometer specifications.



**WED 3** Prototype development engineers determine the best answer to your special problem.



**THURS 4** There's as much preparation for prototype orders of 1 to 10 as there is for runs of 10,000.



**FRI 5** Project engineer supervises production in Spectrol's special prototype model shop.

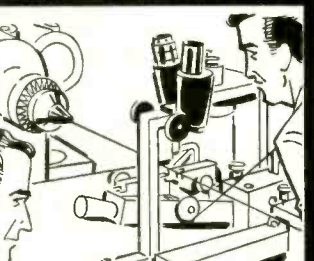

**MON 6** Coils are specially made on Spectrol's hi-precision winding equipment.



**TUES 7** Assembly takes place in Spectrol's dust-free conditioned-air laboratory.

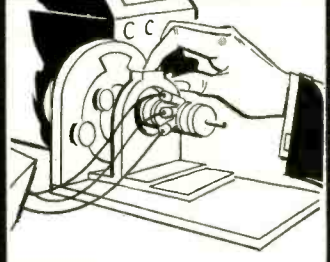

**WED 8** Your finished prototype checks-out on complete test equipment of finest caliber.

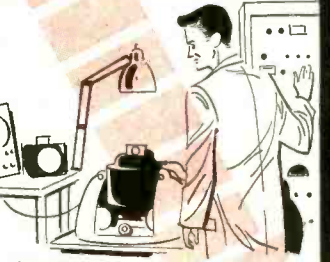

**THURS 9** Proves itself against your special electrical, physical, and environmental specifications.



Then your potentiometer (from order to reality) is delivered to you — in 10 days! **FRI 10**

**SPECTROL IS FIRST TO MEET  
INDUSTRY'S FAST PROTOTYPE DEMANDS**

Even though Spectrol's regular 30 to 45 day delivery is only half the time you often wait for a prototype potentiometer—we now offer special service to meet urgent needs with 10 day delivery from our new prototype development center. And (just as important) Spectrol backs this unprecedented service with dependable delivery against your follow-up production-run orders in 30 days.

That means, with Spectrol you can actually be in production long before you would receive your first prototype elsewhere. Remember Spectrol—for any of your potentiometer requirements—standard or special!

**A COMPLETE LINE OF PRECISION POTENTIOMETERS**



Single-turn



Multi-turn



Miniature

**SPECTROL**

**SPECTROL ELECTRONICS**

DIVISION OF CARRIER CORPORATION  
1704 South Del Mar, San Gabriel, Calif.

**ONLY 10 DAYS TO DELIVER**



**SPECTROL POTENTIOMETER PROTOTYPES**

**Save weeks  
when every  
day counts!**

**CALL YOUR NEARBY  
SPECTROL  
REPRESENTATIVE**

Brooks, Feeger & Morrow  
ALBUQUERQUE • 81724

Samuel K. Macdonald, Inc.  
BALTIMORE • Clifton 49966

Gerber Sales Company  
BROOKLINE, MASS.

Beacon 22425  
Jerry Vrbik  
CEDAR RAPIDS • 40833

Knoblock & Malone  
CHICAGO • SPaulding 29892

Thomson Engineering Service  
DALLAS • FLeetwood 77885

Thomeo Electronics  
DAYTON • HE 4734

Brooks, Feeger & Morrow  
DENVER • ALPine 51196

A.B.M. Sales Company  
DETROIT • UNIVERSITY 21300

Spectrol Sales Dept.  
SAN GABRIEL, CALIF.  
AT. 91478

Fred B. Hill Company  
MINNEAPOLIS • West 96727

Gerber Sales Company  
NEW HAVEN • Spruce 76279

Samuel K. Macdonald, Inc.  
PHILADELPHIA  
Kingsley 52105

Brooks Feeger & Morrow  
PHOENIX • AMhurst 50274

Samuel K. Macdonald, Inc.  
PITTSBURGH  
Atlantic 12253

Seatronics, Inc.  
1806 Bush Place  
SEATTLE 44, WASHINGTON

I. A. Holtz  
SYRACUSE • 97387

D. R. Bittan Company  
VALLEY STREAM, L. I.,  
NEW YORK  
Locust 12444

Samuel K. Macdonald, Inc.  
WASHINGTON, D. C.  
COLUMBIA 53938

Uni-Office, Ltd.  
ROTTERDAM, HOLLAND

Circle 65 Readers Service Card



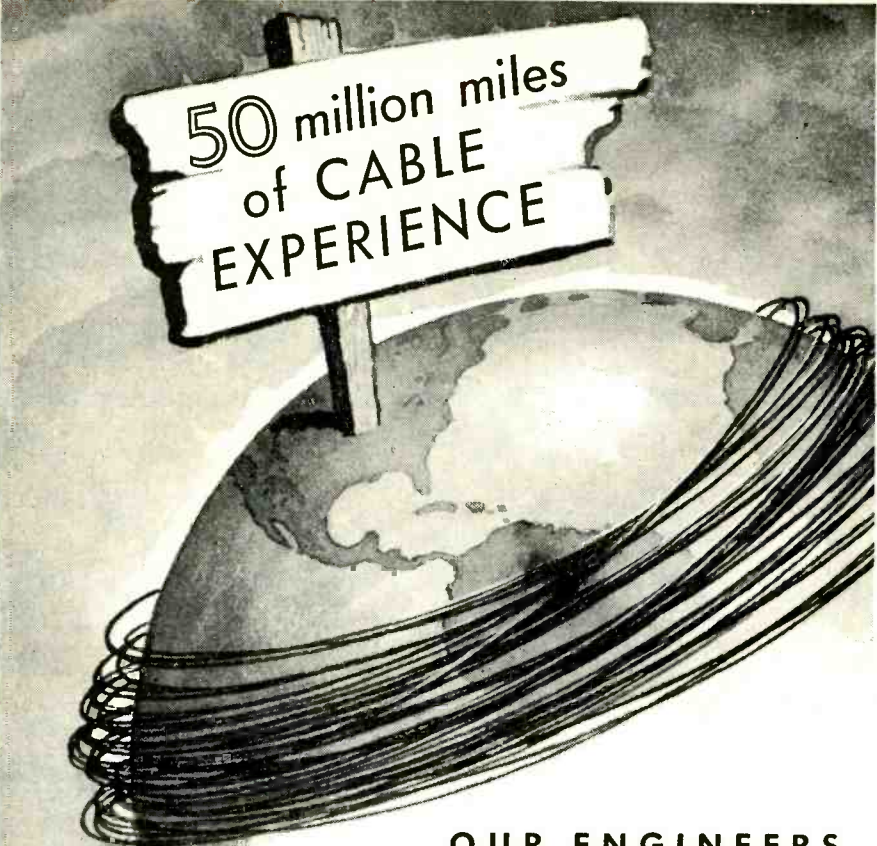

50 million miles  
of CABLE  
EXPERIENCE

**OUR ENGINEERS**  
have had millions of miles of  
experience in producing multi-  
conductor cables.

Whether it be a few or a hundred conductors,  
whether they be braided, wrapped, foiled,  
striped or jacketed, we have yet to hear our  
engineers say "we can't do it."

Why not take up your cable requirements with  
us? Specially designed and custom built  
cables are our everyday accomplishment.

SPECIFY



FOR SURE PERFORMANCE

**PLASTOID**  
Corporation

Plant: HAMBURG, N. J. • Offices: 42-61 24th Street, Long Island City 1, New York

ceiver is mounted on a standard 8 $\frac{1}{2}$  by 19 in. panel. When transmitting, +15 dbm carrier is used for selective calling and receiver avc. At full modulation, the sideband power is +26 dbm or 400 mw peak envelope power. Because the transceiver is completely transistorized, the total battery drain from a 24 v d-c source is only 400 mw when receiving and 4 w when transmitting. Selective calling components are mounted on an adjacent panel.

The equipment is applicable to any service where physical circuits are limited by line noise or overloading and will provide additional talking circuits at a fraction of the cost of installing additional physical circuits. Circle 427 inside back cover.



**STEP INPUT UNIT**  
for use with X-Y recorder

F. L. MOSELEY Co., 409 N. Fair Oaks Ave., Pasadena, Calif. Data plotting at any number of preset increments up to 999 steps along one axis is possible with the new model 51 step input unit. Designed for use with the Autograf X-Y recorder, the unit provides means for producing bar-type graphs to any scale on standard or non-standard graph paper. Completely self-contained, the model 51 visually displays by means of illuminated numbers the content of the mechanism at any point in a test series thus facilitating start and stop operations without losing track of position at any time. Calibration to any scale factor is possible by adjusting both size and number of steps to conform to the data being plotted. Zero may be set at any point. Use of the unit does not require modification of a



DESIGNED TO MEET MIL-E-1

# MILITARY TYPE

## *AUTOMATIC* silicon rectifiers

JAN  
TYPES

1N253

1N254

1N255

1N256



WRITE TODAY FOR  
ENGINEERING  
"SPEC" SHEETS  
FOR ANY TYPE.

The reliability demanded by the rigid electrical, mechanical and environmental specifications of MIL-E-1 is now assured with **Automatic's** JAN TYPE silicon rectifiers . . . offered in production quantities at prices reflecting volume output.

**Automatic** offers, in addition to these JAN types, a complete line of Silicon Rectifiers for industry . . . including magnetic amplifiers, power supply, high voltage, germanium replacement and general purpose types.

### TYPICAL VALUES FOR AUTOMATIC MILITARY TYPE SILICON RECTIFIERS

Type No.	Peak Reverse Voltage (VOC)	DC Output Current AY* (MA)	Maximum Reverse Current** (MA)	Mounting	MIL-E-1 Technical Spec. Sheet No.
1N253	100	1000	0.1	Stud-Mount	1024
1N254	200	400	0.1	Stud-Mount	989A
1N255	400	400	0.15	Stud-Mount	990A
1N256	600	200	0.25	Stud-Mount	991A

\*CASE TEMPERATURE 135°C.

\*\*AVERAGED OVER 1 CYCLE FOR INDUCTIVE OR RESISTIVE LOAD WITH RECTIFIER OPERATING AT FULL RATED CURRENT.

Available JAN TYPES: 1N253, 1N254, 1N255, 1N256

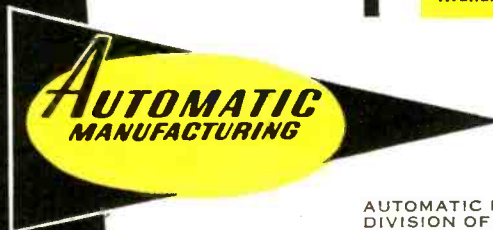

MASS PRODUCERS OF  
ELECTRONIC COMPONENTS

AUTOMATIC MANUFACTURING  
DIVISION OF GENERAL INSTRUMENT CORPORATION  
65 GOUVERNEUR ST.  
NEWARK 4, N. J.



where reliability is a standard

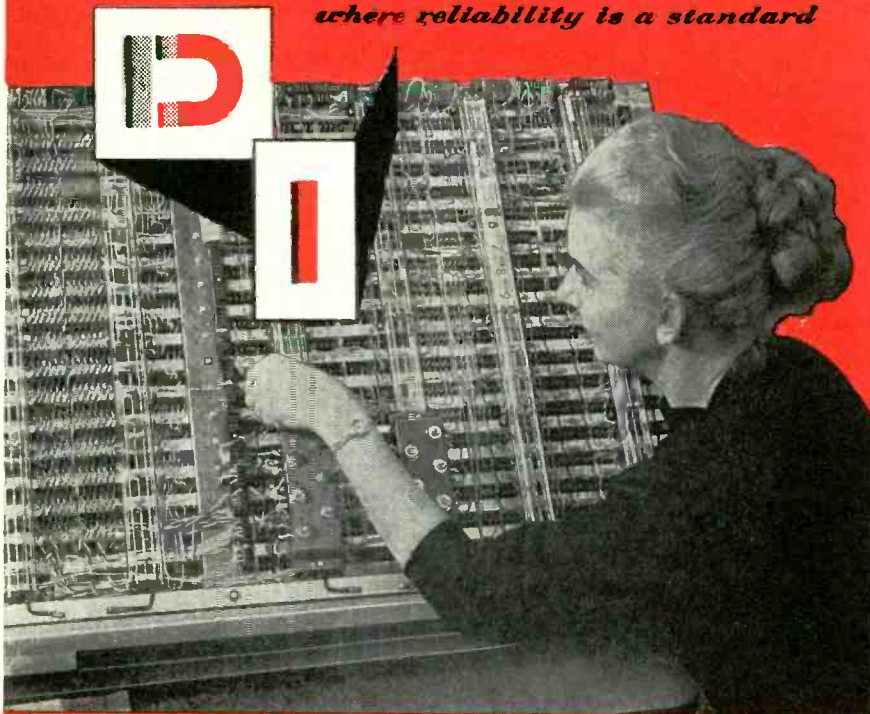

## ELECTRONIC ASSEMBLY

Meeting critical customer requirements for high quality ELECTRONIC ASSEMBLIES is an every day event at Daystrom Instrument.

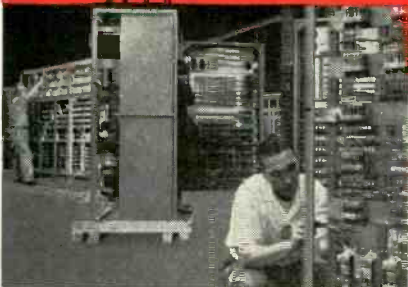

In our modern 350,000 sq. ft. plant we can produce miniature assemblies as well as large console requirements on a production-line basis. Our supporting engineers enable us to do the complete job from design through finished product.



Let Daystrom Instrument assist you in meeting your electronic product needs. One of our sales engineers is ready to discuss our qualifications with you. Write us, and he will call at your convenience.

*JUST OFF THE PRESS! Our New Facilities Brochure. Write for it!*



**DAYSTROM INSTRUMENT**  
Archbald, Pennsylvania  
Division of Daystrom Inc.

Visit Our Booth No. 315 At Wescon—Aug. 20-23

NEW PRODUCTS

(continued)

standard recorder. Circle 428 inside back cover.

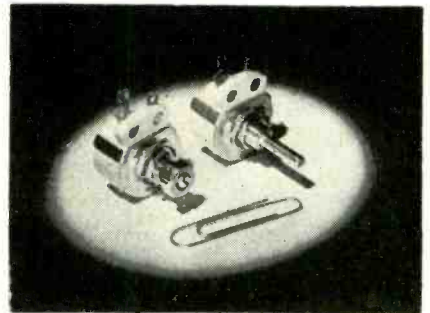

### MINIATURIZED POTS use new molding material

CLAROSTAT MFG. CO., INC., Dover, N. H. Further refinement of the series 49M miniaturized wire-wound potentiometer, by way of still higher dielectric strength, has been announced.

A new molding material, green in color, is now used in these potentiometers. This feature, together with design refinements, results in exceptionally low electrical leakage in operation. Tests indicate complete compliance with the high performance standards set for miniaturized components in the most critical applications.

Series 49 M pots are  $\frac{3}{4}$  in. in diameter by  $\frac{1}{2}$  in. deep; 1.5 w; 4 ohms to 20,000 ohms resistance. Circle 429 inside back cover.



### TUBE SHIELDS large in diameter, length

INTERNATIONAL ELECTRONIC RESEARCH CORP., 145 West Magnolia Blvd., Burbank, Calif. The NW type shield (NW6-6528) was designed especially for the Bendix 6094 tube and tubes of the same bulb size. These tubes are larger in diameter and length than the



BURTON BROWNE/New York

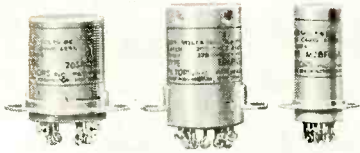

EXCLUSIVE WITH  
**FILTORS, INC.**

## **ONLY PRECISION MACHINED ROTARY RELAY**

NO STAMPED PARTS IN THE MOTOR. MACHINED PARTS—ONLY ONE OF THE ADDITIONAL QUALITY CONTROL STEPS TAKEN BY FILTORS IN THE MANUFACTURE OF HERMETICALLY SEALED SUB-MINIATURE RELAYS . . . YOUR ASSURANCE OF GREATEST RELIABILITY.

WRITE FOR CATALOG, FILTORS, INC., PORT WASHINGTON, LONG ISLAND, NEW YORK, PORT WASHINGTON 7-3850

**Low noise level**  
**Wide frequency response**  
**High input impedance**

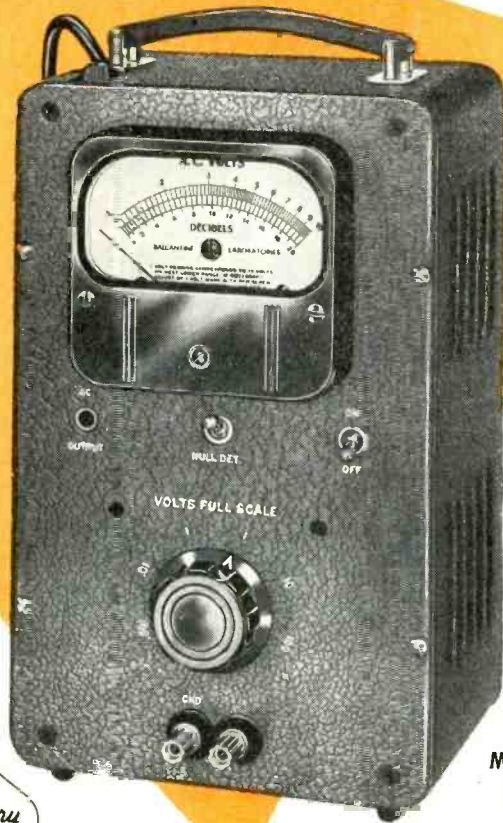

**MODEL 310A**  
 Price \$235



## ... with this BALLANTINE Sensitive Electronic Voltmeter

To measure .....	40 microvolts to 100 volts
from .....	10 cycles to 2 megacycles
with accuracy ( $>100 \mu v$ ) .....	3% to 1 mc; 5% above
Shorted input noise .....	less than 20 microvolts
Input impedance .....	2 megohms shunted by 19 mmfd below 10 mv; and by 9 mmfd above

Usable as null detector sensitive to  $10 \mu v$  from 5 cps to 4 mc

### NOTE THE MANY USES OF THIS BALLANTINE VOLTMETER:

- Acoustic measurements
- Low level vibration measurements
- Audio amplifier tests
- Carrier telephone transmission
- Ultrasonic development
- AM broadcast band signal measurements

Write for catalog for more information about this and other BALLANTINE voltmeters, amplifiers, and accessories.

**BALLANTINE LABORATORIES, INC.**

100 FANNY ROAD, BOONTON, NEW JERSEY



usual 9 pin noval tube. The NW shield assembly consists of an aluminum shell, a phosphor bronze compression spring and an inner beryllium copper spring finger liner. This assembly locks into a brass MIL type B base T6-1001. The spring finger liner grasps the glass bulb and dissipates the heat by conduction, radiation, and convection. This shield will lower the bare bulb temperature of a 6094 tube operating at 16 w filament and plate dissipation by more than 60 C. The shield assembly and base retain the tube under extreme shock and vibration conditions. This type shield is also available to fit all standard sizes of 7 and 9 pin miniature tubes.

For retrofitting equipment having old style JAN bases, a TR shield is available to fit the 6094 tube. In this assembly (TR6-6027-1) attachment to the base is accomplished by a snap-on type lock which offers superior retention of the tube under shock and vibration environments. The reduction of the bare bulb temperature afforded by this shield is 35 C under conditions described for the NW type shield. The TR type shield is also available to fit all standard size 7 and 9 pin miniature tubes. Circle 430 inside back cover.



### TINY CAPACITORS

for high temperature use

DEARBORN ELECTRONIC LABORATORIES, 1421 North Wells St., Chicago 10, Ill. Deltaply 165 capacitors offer a new low in volume and a new high in reliability over the temperature range  $-65 \text{ C}$  to  $+165 \text{ C}$ . As an example of the size, a  $1.0 \mu f$ , 200 v unit requires 3.8 cu in. The same unit in Teflon requires 6.4 cu in. Capacitance change over the full temperature range will amount





# NEW DC-to-10MC OSCILLOSCOPE

requires only 7 inches of rack height

A new 3" rack-mounting oscilloscope, the Tektronix Type RM16, combines high performance with small size to help ease the space problem in rack installations. It measures only 7" high, 19" wide, 16 3/4" rack depth, 19 1/4" overall depth. For servicing convenience, the RM16 can be tilted vertically on its modern slide-out mounting.

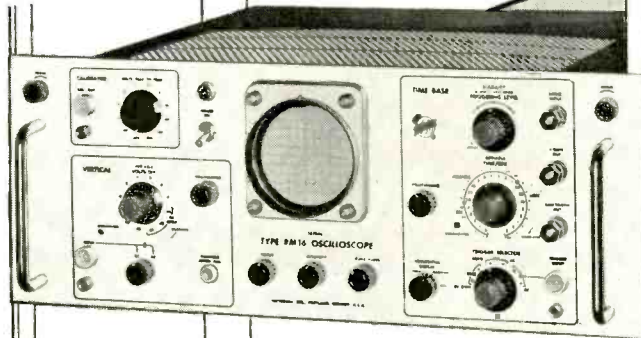

## DC-COUPLED VERTICAL AMPLIFIER

Main Amplifier passband is dc to 10 mc, risetime 0.035  $\mu$ sec. Vertical deflection is calibrated in steps of 0.1, 0.2, 0.5, 1, 2, 5, 10, 20, and 50 v/div. An ac-coupled preamplifier provides three additional steps of 0.01, 0.02, and 0.05 v/div at a frequency response of 2 cycles to 9 mc, risetime 0.04  $\mu$ sec. Calibration accuracy is within 3% of the panel reading. A vernier (uncalibrated) control provides for continuously-variable adjustment from 0.01 v/div to 125 v/div. Balanced network provides 0.25- $\mu$ sec signal delay. Input capacitance is 38  $\mu$ f direct, 13  $\mu$ f with probe.

## WIDE-RANGE SWEEP CIRCUIT

A single knob is used to select any of 22 calibrated sweep rates from 0.2  $\mu$ sec/div to 2 sec/div. Calibration accuracy is typically within 1% of full scale, and in all cases within 3%. A vernier (uncalibrated) control provides for continuously-variable adjustment from 0.2  $\mu$ sec/div to 6 sec/div. The unblanking waveform is dc-coupled to the crt grid, assuring uniform bias for all sweep and repetition rates.

A sweep magnifier expands the normal sweep to 50 divisions, any 10 of which can be positioned on the screen, increasing the calibrated sweep range to 0.04  $\mu$ sec/div. The magnified sweep rate is read directly from the panel. Calibration accuracy is within 5% of the displayed portion of the magnified sweep.

## FOUR-WAY TRIGGERING

1. Amplitude-Level Selection—adjustable amplitude-level and stability controls for triggering at a selected level on external, internal, and line signals—either polarity—ac or dc-coupled.
2. Preset Stability—same as above, except stability is preset at the optimum triggering point and requires no readjustment.
3. Automatic Triggering—automatic level-seeking trigger circuit provides dependable triggering for most applications, even on very small signals, through wide changes in amplitude, frequency, and shape of the triggering signal. Provides a reference trace on the screen when no trigger signal is present.
4. High-Frequency Sync—assures a steady display of sine-wave signals up to approximately 20 mc.

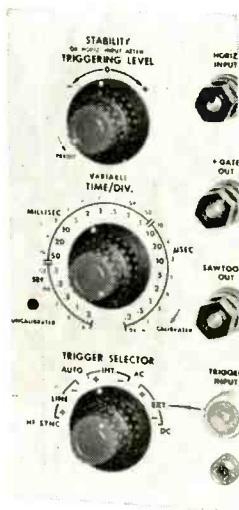

## OTHER CHARACTERISTICS

Voltage calibrator has 11 fixed peak-to-peak outputs from 0.05 to 100 volts. Accuracy is within 3%. Square-wave frequency is approximately 1 kc.

New 3" Tektronix cathode-ray tube, Type T31P2, is used. Optional phosphors are P1, P7 and P11. Accelerating potential is 1.85 kv.

Horizontal amplifier can be driven by an external signal. Deflection factor is approximately 1.4 v/div, frequency response dc to 500 kc.

Power supplies are electronically regulated. Type RM16 operates on 105 to 125 v or 210 to 250 v, 50 to 60 cycles, 260 watts. Type RM16-S1 operates on 50 to 800 cycles, uses dc fan motor.

## EASY ACCESSIBILITY

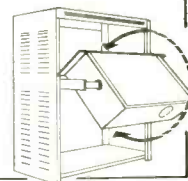

The Type RM16 will also be available with power supply separated from indicator unit for racks with limited depth. Dimensions are: Indicator Unit—7" high, 19" wide, 11 3/8" deep... Power Supply—7" high, 19" wide, 5 1/2" deep.

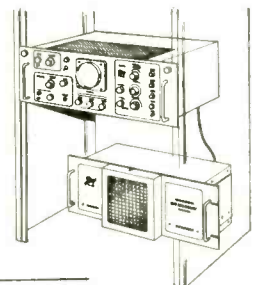

First shipments of the Type RM16 are expected to be made during November 1957. Please keep in touch with your Tektronix Field Engineer or Representative for current details.

See the Type RM16 and other new Tektronix instruments at WESCON, booths 1701, 1702.

# Tektronix, Inc.

P. O. Box 831 • Portland 7, Oregon  
Phone CYPress 2-2611 • TWX-PD 265 • Cable: TEKTRONIX

**ENGINEERS**—interested in furthering the advancement of the oscilloscope? We have openings for men with creative design ability. Please write Richard Ropiequet, Vice President, Engineering.

# FREE BOOKLET . . . tells about working with "the leaders" on exciting, advanced projects

We're proud of our men and of the work they do. We'd like you to become better acquainted with the setting in which they work, live and play.

With your permission, we'd like to send you a booklet describing their activities and your opportunities at the Mechanical Division of General Mills.

No need to write a letter for your copy. Just send the coupon below. We'll not bother you further, and of course, we'll send the booklet in complete confidence.

If, after reading the booklet, you'd like still more information or see a chance to do big things with the type of company you've always wanted to be with, we'll gladly send you more facts. Or, perhaps we can get together for a personal visit.

## capsules from the Mechanical Division "OPPORTUNITY BOOKLET"

**RECOGNITION** We help our people realize their fullest capabilities—pay accordingly. Deserving persons advance rapidly.

**FINANCIAL SECURITY** We're one of the nation's largest most diversified companies. (We've paid dividends without reduction since 1929.)

**TIME FOR FUN . . .** and hundreds of places to have it, the year around, in the land of 10,000 lakes.

**CONGENIAL ASSOCIATES** Our people tell us they like their work. Our extremely low rate of turnover says so too. They're friendly, ordinary people (with extraordinary talents) who like to see a job well done.

**COST OF LIVING IS LOWER . . .** shops are complete, easy to get to.

**DELIGHTFUL RESIDENCES** And inexpensive too. Many General Mills families own "dream" homes in resort-like settings only minutes from work.

**SUPPLEMENTARY BENEFITS . . .** all the usual ones and more besides.

**SCHOOLS ARE EXCELLENT . . .** with low pupil-to-teacher ratio.

All inquiries will be kept in strict confidence.

## MECHANICAL DIVISION OF

Minneapolis 13, Minnesota



Peter D. Burgess, Personnel Director—AL  
Mechanical Division General Mills  
1620 Central Avenue Northeast  
Minneapolis 13, Minnesota

Name .....

Address .....

City ..... State .....

College ..... Degree ..... Year .....

For a copy of this interesting, informative booklet, complete the coupon and mail today.

### Booklet Tells About Exciting Opportunities in These Fields:

Missiles

Applied Mechanics

Geophysics

Underwater Ordnance

Electronic Countermeasures

Digital & Analog Computers

Instruments & Controls

Solid State Physics

Microwaves & Antenna

Infrared Systems

Inertial Systems

Systems Analysis & Design

Servomechanisms

Balloon Systems

Upper Atmosphere Research

Fine Particle Technology

Surface Chemistry

Optics

Mechanical Design

Airborne Early Warning

Radar Systems

Information Theory

Production Engineering

to less than 9 percent.

Insulation resistance in meg-ohms  $\times$  microfarads varies from 200,000 at 25 C. The self-healing, metallized, plastic film provides unusually long life at 165 C with no voltage derating.

Capacitance values from 0.001 to 10.0  $\mu$ f, may be obtained in hermetically sealed metal tubes or double-lock seal tubular cans. The smaller sizes are also available uncased. Standard voltage ratings are 200, 400 and 600. Circle 431 inside back cover.

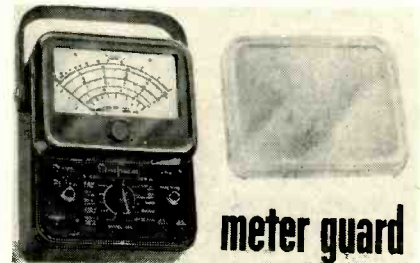

### METER COVER prevents costly damage

ELECTRONIC DEVELOPMENT LABORATORIES, 71 Nassau St., New York 38, N. Y. Meter Guard is a transparent protective meter cover for Simpson instruments, models 260, 303, 276 and 880. Made of Super-Strong Involex this invisible shield slips on over the Bakelite meter case to constantly protect against dropped tools and other hazards. The Meter-Guard works while the instrument is in use or in transit, thereby preventing costly and annoying damage to meter glass, case and movement. It is unconditionally guaranteed. Circle 432 inside back cover.

### DIGITAL CODER transistorized 10-bit unit

RADIATION, INC., P. O. Box 37, Melbourne, Fla., has developed a completely transistorized 10-bit digital coder. Constructed entirely on printed wiring boards, the unit is extremely compact and resistant to high shock and vibration conditions.

The coder uses the "half-split" sampling technique and operates



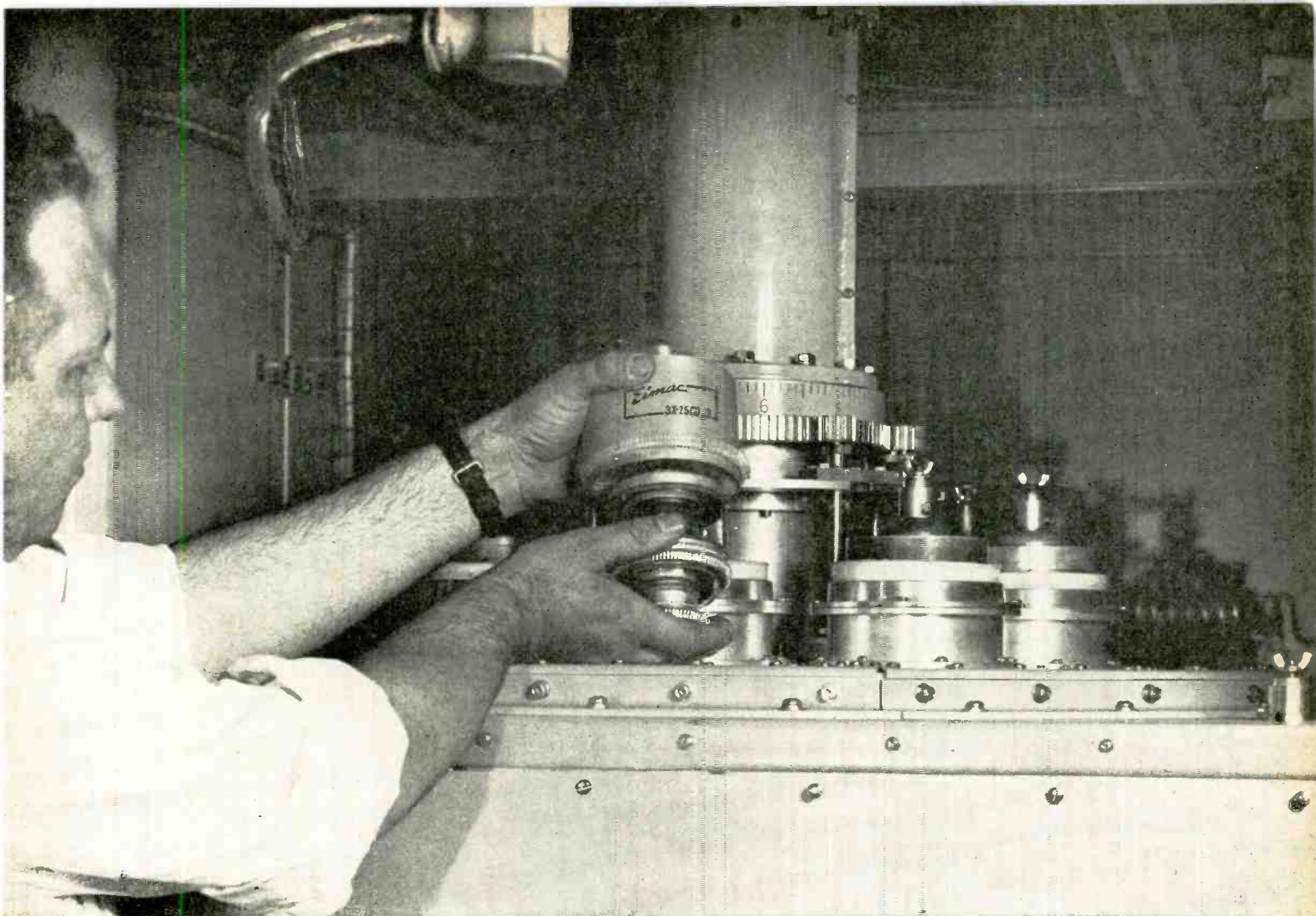

Final Amplifier Stage, model TX-264,  
developed by Rixon Electronics, Silver Spring, Maryland.

## Rixon uses 8 Eimac triodes in final amplifier to get 60 KW of ionospheric scatter power

Eight Eimac 3X2500A3 triodes in parallel make up the tube complement of this co-axial power amplifier in the new 60 KW Rixon ionospheric scatter transmitter. A total of 11 Eimac 3X2500A3's are used in the RF circuitry, which eliminates need for a complex stock of replacements.

In the modern Rixon transmitter, a hundred watt exciter drives a 2KW first stage, utilizing one Eimac 3X2500A3. This stage delivers up to 2 KW to the second stage which uses two Eimac 3X2500A3's. This stage can be connected to the antenna to deliver ten KW power or used to excite the final co-axial amplifier occupying five cubic feet and using eight 3X2500A3's. This unusual final amplifier will deliver up to 60 KW of useful power. Rixon engineers indicate a final amplifier apparent efficiency of 85 per cent at 60 MC, while the overall efficiency to all three amplifier stages is a remarkable 67.5 per cent!

Discriminating Rixon engineers bore several important factors in mind when they selected the Eimac 3X2500A3 for this transmitter:

1. Its small size (9 by 4.16 inches) simplifying storage and shipping problems.
  2. Its moderate cost.
  3. Its rugged, sturdy space-saving construction.
  4. Its delivery of a full 7.5 KW output up to 110 MC.
- Ever since "the big signal" on 50 MC Eimac has been the leader in providing the tubes for ionospheric scatter.

**EITEL-McCULLOUGH, INC.**  
SAN BRUNO · CALIFORNIA  
*Eimac First with power for ionospheric scatter*



See Eimac Tubes That Can Take It at WESCON, San Francisco Cow Palace, August 20-23, booths number 1706 and 1727-28.

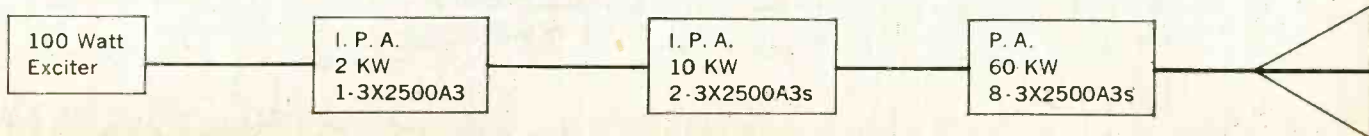



Where the temperature hits 200°C. or the dry circuit is downright arid, your best bet for reliability is a "Diamond H" Series R miniature, hermetically sealed, aircraft type relay. Their shock and vibration resistance you may take for granted.

On the other hand, Series R relays (4 PDT) also give excellent reliability at -65°C. and will carry up to 10 amperes in power circuits . . . or even 20 amperes for short life requirements. In other words, they offer an extremely wide range of performance characteristics from which "Diamond H" engineers will be happy to work out a variation to meet your specific requirements. Just ask.

#### TYPICAL PERFORMANCE CHARACTERISTICS

<b>Vibration Resistance:</b>	10-55 cycles at 1/16" double amplitude 55-500 cycles at 15 "G" 55-1,000 cycles at 15 "G" 55-2,000 cycles at 20 "G"
<b>Temperature Range:</b>	-55° to +85°C. -65° to +125°C. -65° to +200°C.
<b>Coils:</b>	Resistances—1 ohm to 50,000 ohms Arrangements—single coil; two independent coils, either or both of which will operate unit
<b>Insulation Resistance:</b>	1,000 megohms at room temperature 100 megohms at 200°C.
<b>Dielectric Strength:</b>	450 to 1,000 V., RMS
<b>Operating Time:</b>	24 V. models 10 ms. or less; dropout less than 3 ms.
<b>Contacts:</b>	30 V., D.C.; 115 V., A.C.; 2, 5, 7½ and 10 A., resistive; 2 and 5 A. inductive. Minimum 100,000 cycles life. Low interelectrode capacitance—less than 5 mmf. contacts to case; less than 2½ mmf. between contacts. Special Ratings: to 350 V., D.C., 400 MA., or other combinations including very low voltages and amperages or amperages to 20.
<b>Operational Shock Resistance:</b>	30, 40 and 50 "G" plus
<b>Mechanical Shock Resistance:</b>	up to 1,000 "G"
<b>Mounting:</b>	9 standard arrangements to meet all needs —plus ceramic plug-in socket.
<b>Size:</b>	1.6 cu. in.
<b>Weight:</b>	4 oz. or less

Bulletin R-250 gives more complete data. Send for a copy.

**THE HART MANUFACTURING COMPANY**  
202 Bartholomew Avenue, Hartford, Conn.

at 24,000 samples per sec with a bit rate of 264 kc. It accepts voltage inputs between  $\pm 5.12$  v with an input impedance of 1 megohm. The unit will digitize one channel of analog voltage with a frequency response of 12 kc. It will digitize any number of channels in conjunction with a multiplexer. The output is either serial binary or parallel binary code as desired. Circle 433 inside back cover.

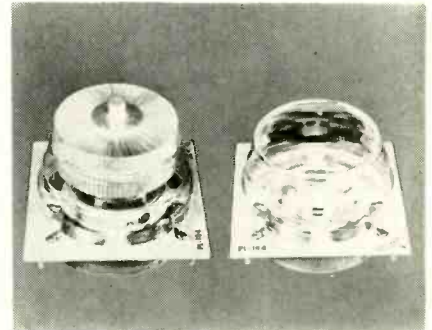

#### TUBE SOCKET

for 1,000-w beam pentode

PENTA LABORATORIES, INC., Santa Barbara, Calif., has announced the availability of a socket designed especially for its PL-172, 1,000-w beam pentode tube. The new type socket, PL-184, provides connections for all tube terminals, including the suppressor-grid and screen-grid rings, and also includes air-flow directing means for proper cooling of the anode and seals. Capacitors built into the socket provide low-inductance r-f by-passing for the suppressor grid and screen grid of the PL-172. Circle 434 inside back cover.

#### PRECISION SWITCHES

miniaturized units

HAYDON SWITCH, INC., Waterbury, Conn., has developed plastic body precision switches, so small that nine could fit into one cu in. of space.

The No. 5300 series switches measure only  $\frac{3}{32}$  in. by  $\frac{1}{8}$  in. by  $\frac{1}{4}$  in. Two No. 5302 switches can be mounted, activator to activator and operated in a 1-in. diameter tube. These subminiature precision



**SOLA CONSTANT  
VOLTAGE TRANSFORMER**

+

**HIGH CAPACITANCE  
FILTER SECTION**

+

**GERMANIUM  
RECTIFIER**



**DC SOLAVOLT**, shown partly disassembled here, has major components identified. It is designed for relay-rack mounting on a standard, 19" frame or for bench use. Removable handles, for convenience when portability for bench use is desired, are available as accessory equipment.

## Unique combination of components in adjustable "DC Solavolt" regulated power supply reduces conventional size, weight, and cost

Compact size, low weight, high efficiency, and moderate price distinguish the new "DC Solavolt" from conventionally-designed, regulated, adjustable dc power supplies. These outstanding advantages have been secured by using a unique assembly of components (shown above) that occupy only 7" of height and 12¼" of depth on a standard, 19" relay rack frame.

Along with design simplicity, the "DC Solavolt" provides laboratory standards of performance:

**OUTPUT VOLTAGE REGULATED WITHIN  $\pm 1\%$**  at full load with supply voltage variations up to  $\pm 15\%$ . (Regulation within  $\pm 1.5\%$  at 50% load and lowest voltage setting.)

**RIPPLE VOLTAGE HELD WITHIN 0.10% (rms)** at full load and nominal input voltage.

An important feature of this adjustable dc power supply is its ability to handle transient or "pulse" loads of up to twice the full load rating of the supply. The "DC Solavolt" has no tubes to replace, requires no "compensating" or "zero" adjustments, and needs no maintenance.

Six stock models provide outputs *adjustable in voltage ranges between 5 and 400 volts and load currents up to 7 amperes*. Your local electronic distributor now has the "DC Solavolt" in stock. He will be happy to give you further, technical information.

**SOLA** *Constant Voltage*  
**DC POWER SUPPLIES**



Write for Bulletin 7H-DC-245  
See this equipment  
at WESCON,  
Sola Booth 2610

CONSTANT VOLTAGE TRANSFORMERS • LIGHTING TRANSFORMERS • CONSTANT VOLTAGE DC POWER SUPPLIES  
SOLA ELECTRIC CO., 4633 West 16th Street, Chicago 50, Illinois, Blshop 2-1414 • BRANCH OFFICES: Boston, Mass.; Cleveland, Ohio; Kansas City, Mo.; Los Angeles, Calif.; New York, N. Y.; Philadelphia, Pa.; San Francisco, Calif.; Wallingford, Conn. • Representatives in Other Principal Cities.  
Sola Electric (Canada) Ltd., Toronto 17, Ontario: 102 Laird Drive, Mayfair 4554

*Between Concept and Configuration*

*...Save Time and Money with*

# PHILBRICK PLUG-IN DC AMPLIFIERS



**AVAILABLE FROM STOCK**

For a wide variety of instrumentation and control problems, you can facilitate rapid set-up with either one or both of these octal-based, plug-in Philbrick Amplifiers. Operational Amplifier, Model K2-W, features balanced differential inputs for minimum drift and maximum utility. In conventional applications, overall amplifier characteristics are affected solely by the feed-back networks, since the two inputs can be maintained at nearly equal potential with appropriate feed-back circuitry.

For more critical applications where long term drift must be reduced to sub-millivolt levels, Stabilizing Amplifier, Model K2-P, is paired with Model K2-W. Write for free 28 page Plug-In Amplifier Applications Manual-14.

MODEL K2-W	MODEL K2-P
GAIN: 15,000 dc, Open Loop	GAIN: 1,000 dc
POWER REQUIREMENTS: 4.5ma @ $\pm 300$ vdc, 0.6 amps. @ 6.3v	POWER REQUIREMENTS: 2.4 ma @ +300 vdc, 0.45 amps. @ 6.3 vac, 60 cps
OUTPUT RANGE: +50v. to -50v. at 1 ma	INPUT IMPEDANCE: 1 Megohm
RESPONSE: 2 Microseconds rise time, 100 Kc with unity feed-back	STABILITY: Below 100 Microvolts
PRICE: \$24.00 Postpaid	PRICE: \$60.00 Postpaid

GEORGE A. **GAP/R**  
**PHILBRICK**  
RESEARCHES, INC.

230 Congress Street, Boston 10, Massachusetts HUBBARD 2-3225

NEW PRODUCTS

(continued)

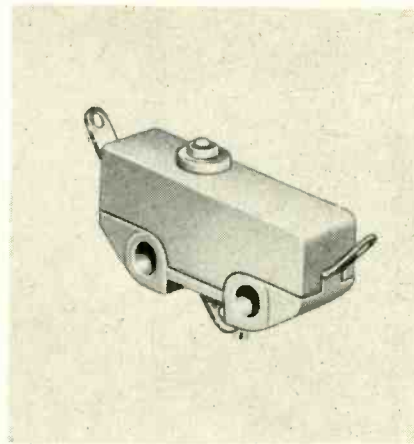

switches can be ganged together in infinite numbers to perform multiple switching functions in confined areas.

Each switch in the 5000 series is available according to specifications as SPNO, SPNC or SPDT. The characteristics are 5 amperes resistive at 28 v d-c; and the same at 115 v a-c. They will operate satisfactorily at -65 deg as well as +250 deg. Circle 435 inside back cover.



## MILLIOHMMETER measures low resistances

THE HERMAN H. STICHT Co., INC., 27 Park Place, New York 7, N. Y., announces the model 47A milliohmmeter, designed for the measurement of low and very low resistances, covering a range from 20 micro-ohms to 1,200 ohms over seven decades. It is a portable, direct reading instrument, line operated with no batteries being required. It employs a-c test currents at line voltage frequency. This overcomes the risk of overheating test equipment under test. With the model 47A, the power dissipated in the test specimen is very small, less than  $\frac{1}{2}$  of a watt in the worst case.

The instrument uses the four



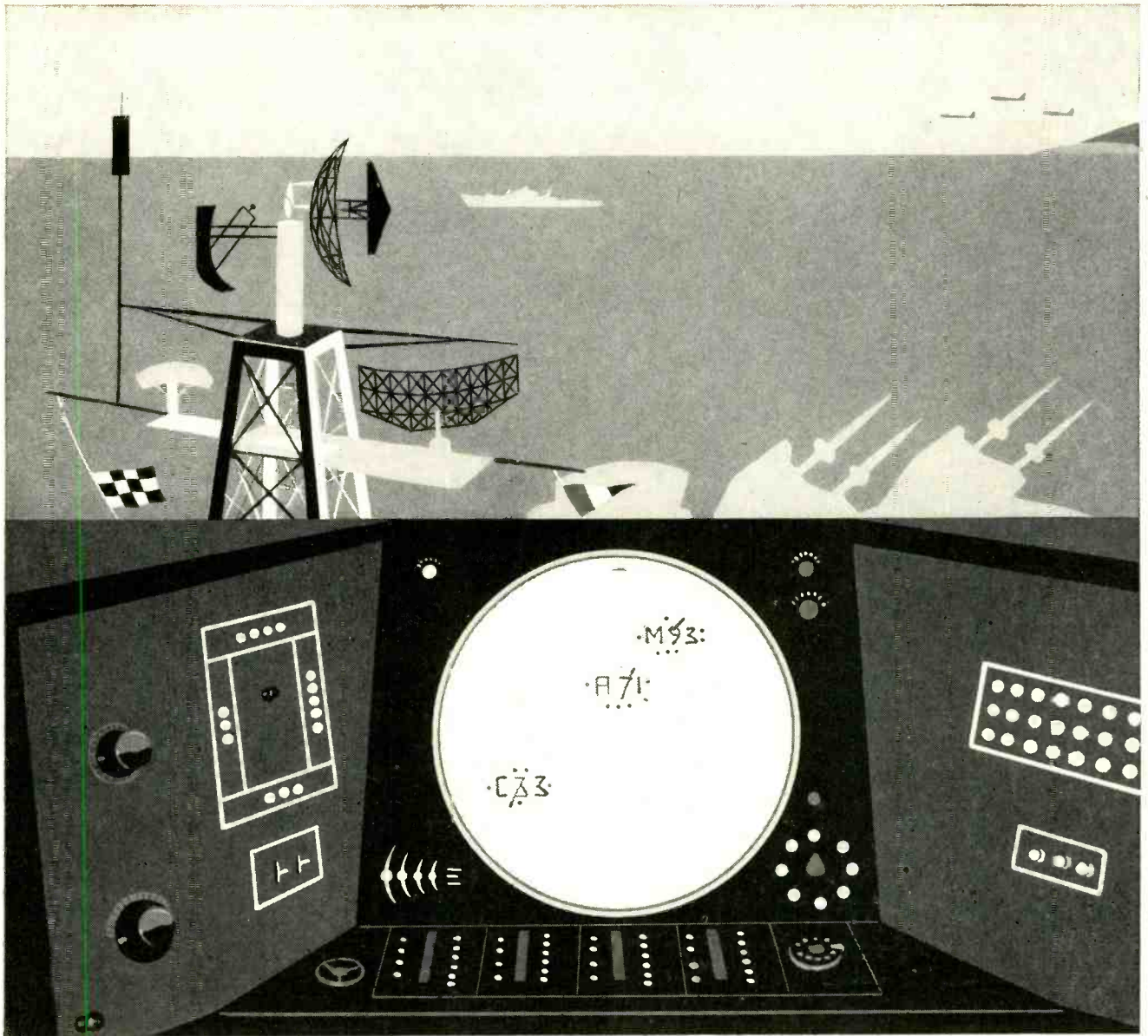

From radar antennas to "readout" equipment...

## AMF has experience you can use

• On land and sea, radar antennas made by AMF play a vital part in the nation's defense system • And converting the incoming radar signals into instantly understandable information are brain-like AMF Electronic Data Display Systems. The ultimate in "readout" equipment, these compact console units accept either analog or digital information, instantly convert, coordinate, and display the data on the face of a cathode-ray tube. Incoming signals can be interleaved with synthetic symbols for immediate reference, and any segment of the display can be offset and enlarged whenever desired. • See for yourself why, for radar control of air, ground, and harbors, or for general-purpose computer reading, AMF has the experience and equipment you can use.

Don't miss  
booths #2303-04  
at the Wescon Show!

- Armament
- Ballistics
- Radar Antennas
- Guided Missile Support Equipment
- Auxiliary Power Supplies
- Control Systems



Defense Products Group  
**AMERICAN MACHINE & FOUNDRY COMPANY**  
1101 North Royal Street, Alexandria, Va.

Asbury Park • Atlanta • Boston • Brooklyn • Dallas • Dayton • Los Angeles • Seattle • Tucson • Washington, D. C.



# 4 CHANNEL ADAR SYSTEM

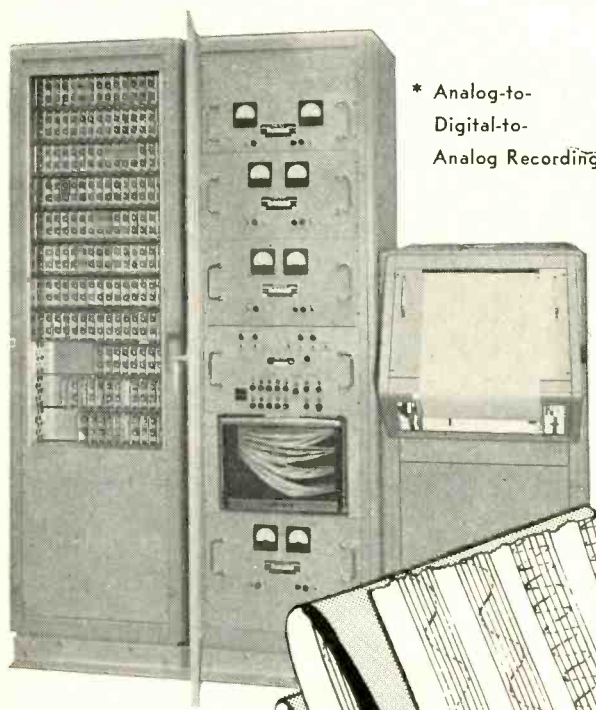

\* Analog-to-Digital-to-Analog Recording.

- IMMEDIATE VIEWING
- PERMANENT RECORD

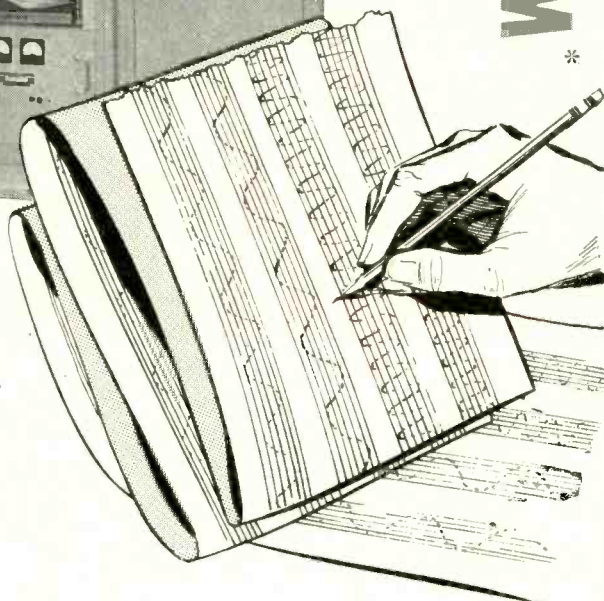

The Model R-1047-1D ADAR System accepts four channels of analog voltage data and plots these data as four non-overlapping quantized analog traces, each trace resolved to one part in 64. The system is particularly suited to the plotting of transient phenomena since the multistylus plotting technique eliminates problems due to damping, overshoot, resonance, and other mechanical limitations. The chart requires no processing, and the plotted data are therefore available for immediate viewing and interpretation.

VISIT OUR EXHIBIT AT WESCON  
BOOTHS 207-208

Write Box 37, Melbourne, Florida for complete data, prices and chart sample.



## RADIATION INC.

MELBOURNE AND ORLANDO, FLORIDA  
ELECTRONICS • AVIONICS • INSTRUMENTATION

Personnel Inquiries Invited.

terminal principle. It incorporates a self-calibration circuit which allows the accuracy of the instrument to be checked at any time in a matter of seconds. Accuracy of the instrument is generally better than  $\pm 2$  percent of full scale. Circle 436 inside back cover.

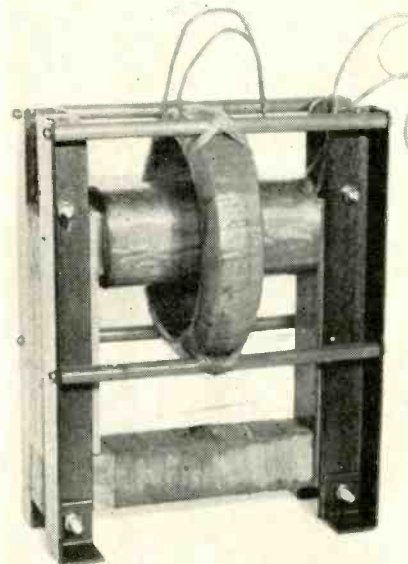

### FILAMENT TRANSFORMER featuring low capacitance

DEL ELECTRONICS CORP., 39-41 North MacQuesten Parkway, Mt. Vernon, N. Y. Illustrated is a typical low capacitance filament transformer designed and manufactured by the company. This particular one is insulated for 50 kv and is rated at 115 v/10v, 10 amperes. Capacitance between secondary and frame is 20  $\mu\text{f}$ .

Other designs with voltage insulation range up to 75 kv, and capacitance range from 10 to 50  $\mu\text{f}$  to suit special requirements are available. Circle 437 inside back cover.

### PLUGS & JACKS made to military specs

KINGS ELECTRONICS CO., INC., 40 Marbledale Road, Tuckahoe, N. Y., is in production on telephone plugs and jacks made according to military specifications, MIL-P-642A and MIL-J-641A. Every plug and jack has undergone exten-



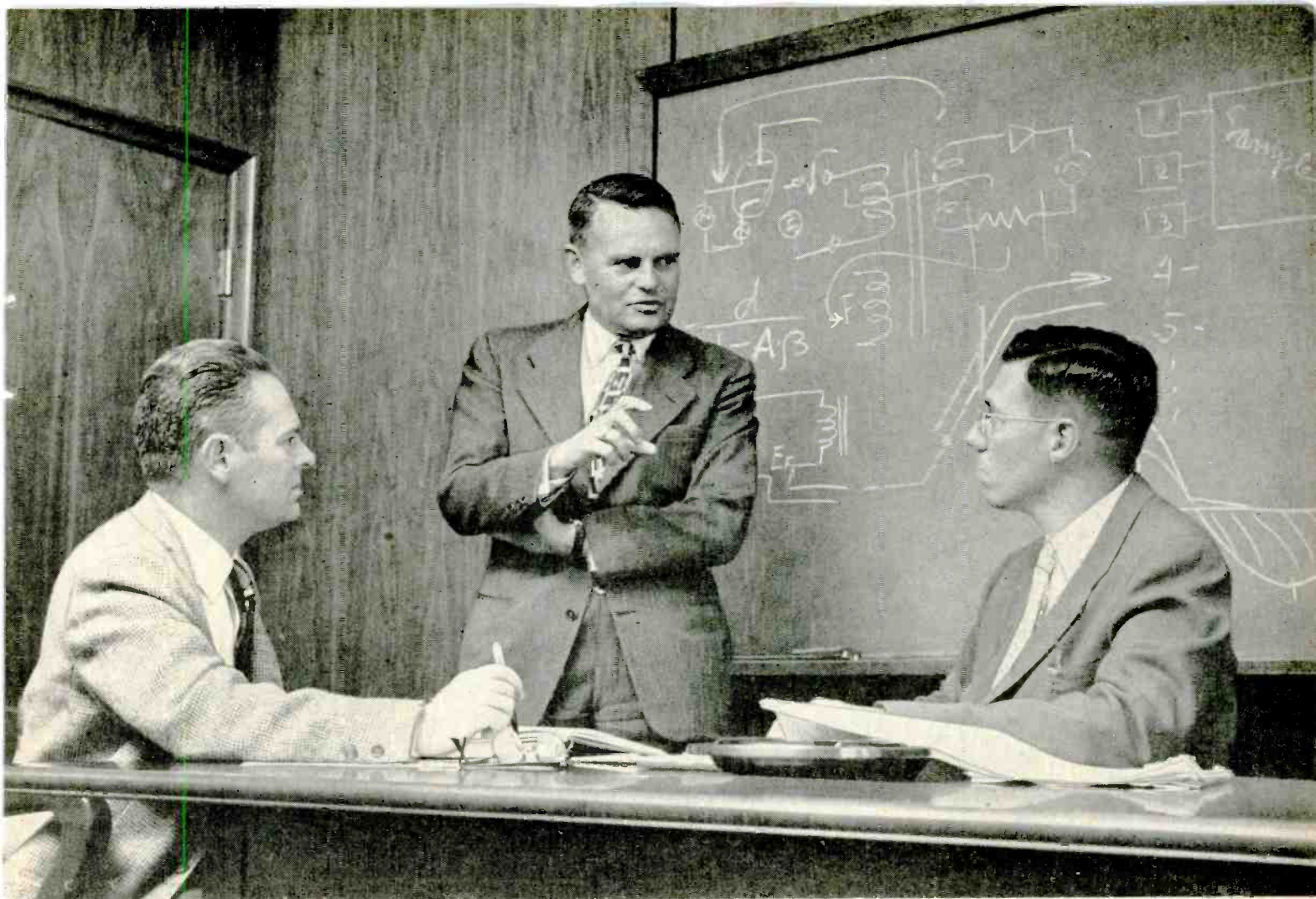

Staff Scientist Dr. J. W. Muehlner (center) discusses an advanced PDM telemetering system for missile application with K. T. Larkin (left), Telecommunications Department manager, and J. R. Dawley, Telecommunications Systems Section head.

## MISSILE SYSTEMS TELECOMMUNICATIONS

Weapon systems programs at Lockheed Missile Systems demand advances far exceeding the current state of telecommunications. Positions are open on the Palo Alto, Sunnyvale and Van Nuys staffs for scientists and engineers possessing a high level of ability and interest in:

**TELEMETRY** — Research in various areas of physics and electronics related to advanced telemetering projects; theoretical analysis of advanced FM, PDM, PCM System concepts; design integration of all phases of telemetry with weapon systems requirements; conception and development of original high-capacity and high-accuracy systems; development and package design of airborne telemetering equipment capable of operating under extreme environmental conditions, including transducers, subminiaturized subcarrier oscillators, crystal controlled FM transmitters, solid state commutators, PDM keys, digital storage and conversion devices; development and prototype design of ground telemetry equipment to include devices such as high-efficiency decommutators, calibrators, digital encoders.

**COMMUNICATIONS** — Application of information theory concepts to challenging communication link problems; analysis and design of microwave communication link components to be utilized in most advanced weapon systems; development and test of television links for special projects.

Address the Research and Development Staff at Sunnyvale 18, or Van Nuys 22, California.



*Lockheed*

### MISSILE SYSTEMS DIVISION

LOCKHEED AIRCRAFT CORPORATION

PALO ALTO • SUNNYVALE • VAN NUYS

CALIFORNIA



## Looking for a Printed Circuit POT?

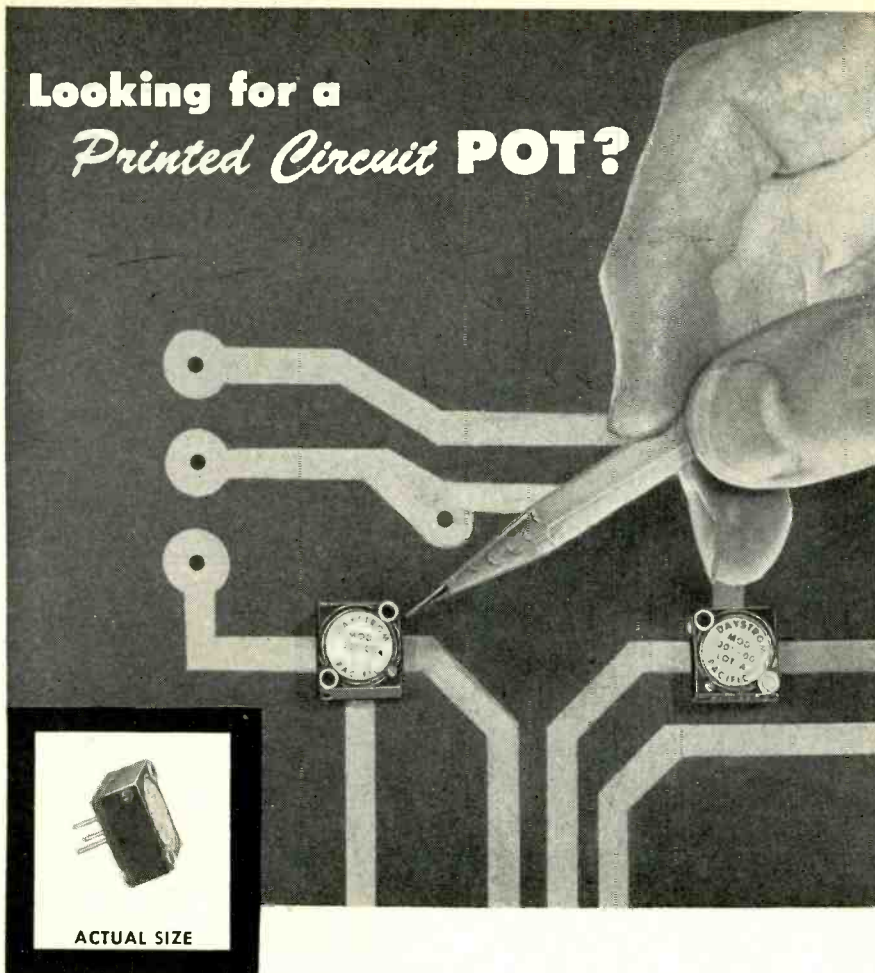

### The 301 PRINTED CIRCUIT "Trimmer"

For circuits with "no room to spare" the minute Model 301 plug-in trimming potentiometer packages pinpoint precision in thumbnail size.

SIZE: 1/2" x 1/2" x 1/4"

WEIGHT: 2 grams maximum

STANDARD RESISTANCE VALUES: 10 ohms to 50K

ADJUSTMENT RATIO: 45:1

IMMEDIATELY AVAILABLE IN PRODUCTION QUANTITIES.

Openings exist for highly qualified engineers

WRITE TODAY FOR DETAILS

**DAYSTROM PACIFIC CORPORATION**

A subsidiary of Daystrom, Inc.

POTENTIOMETER DIVISION

11150 La Grange Avenue, West Los Angeles, California

**D for Daystrom—Daystrom for Dependability**



ACTUAL SIZE

Series  
304

One-turn, Wire-wound,  
Precision  
Potentiometer.

LOW COST  
HIGH PERFORMANCE

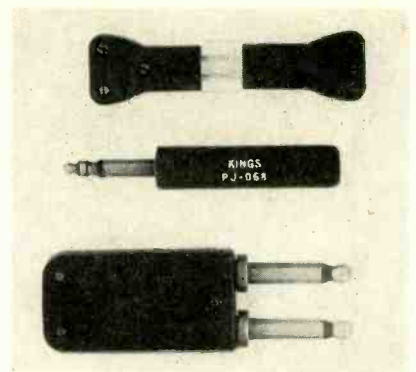

sive life and humidity tests and has received full government approvals. The items illustrated are: top, PJ-292, JJ-055; center, PJ-068; bottom, PJ-327. Circle 438 inside back cover.

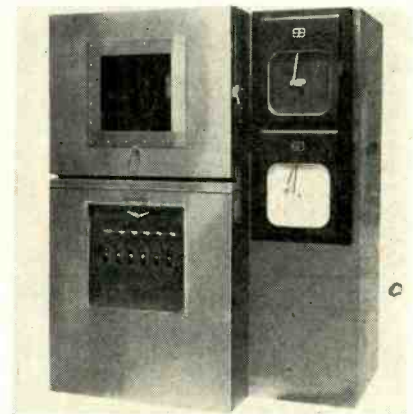

**HUMIDITY TEST CHAMBER**  
has test volume of 8 cu ft

ENVIRONMENTAL EQUIPMENT CO., 369 Linden St., Brooklyn 27, N. Y. Model H8 humidity test chamber simulates environmental conditions throughout the temperature range of 0 deg F to +200 F and 5 percent to 98 percent relative humidity. Controls include 12 in. diameter wet and dry bulb recorder, controller, programmer. Better than  $\pm 2$  F control tolerance is maintained. Interior dimensions are 30 in. wide by 20 in. deep by 24 in. high. Low air velocities are maintained throughout the test space. Circle 439 inside back cover.

**D-C AMPLIFIER**  
features floating input

NEFF INSTRUMENT CORP., 2211 E. Foothill Blvd., Pasadena, Calif. A



# HYCOR precision components



## WAVE FILTERS

Low, high and band-pass types with high "Q" toroid elements. Ranges up to 100 kc., up to 10,000 ohms impedance. Stock types. Also designed for special circuitry or miniaturization.

send for bulletin F-P

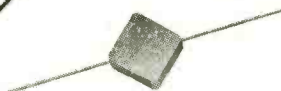

## TOROID COILS

High "Q" factor, excellent current and temperature stability. Encapsulated, fully protected from shock and environmental conditions. Also in encapsulated and metal cased types.

send for bulletin STP

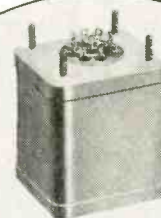

## MAGNETIC AMPLIFIERS

Toroid construction. Standard types with 10,000 or 50,000 power gain. Also designed for specified power, impedance, and response requirements. Cased per military specs.

send for bulletin MA



## RATIO TRANSFORMERS

0.1% accurate even with wide changes in load, frequency, ambient temperature. Up to 1000:1 ratio. Special accuracies to .005%.

Miniature encapsulated and hermetically sealed MIL-T-27 types.

send for bulletin RT



## TELEMETERING FILTERS

Low and band-pass filters. Negligible hum pickup in low level circuits. Excellent phase linearity and attenuation accuracy. Standard and sub-miniature sizes.

send for bulletin TF

## RESISTORS

Encapsulated, for 0.1 watt to 4 watts. Standard tolerance  $\pm 0.1\%$ . Fully protected. Exceed



MIL-R-93A spec. With axial or radial leads, lugs, or leads for printed circuitry.

send for bulletin PH



## DECADE INDUCTOR UNITS

Accurate, stable inductance values for design or experimental work at 150 to 20,000 cps. Four types: .001, .01, .1 or 1 Henry per step. 2% accuracy per step.

send for bulletin D-2



## POWER TRANSFORMERS

Miniature encapsulated types rated 14 V.A. Precise regulation—no external fields. 375 to 525 cps, primary voltage 115, 28 or 12.6 V. Multiple secondaries. Specials supplied.

send for bulletin WT



## PROGRAM EQUALIZER

Bridged T constant impedance type, low and high selectors. Impedance: 500/600 ohms in-out. 14 db insertion loss. Pad compensation with key in "out" position.

send for bulletin E



## MAGNETIC CLUTCHES

Only 1" a.d., but deliver torque of 15 oz. in. on 2 watts. 5 millisecond response. Gear, cable or direct-in-line drives.

Economical for multiple clutching assemblies. send for bulletin C-2



# HYCOR



## VARIABLE FILTER

Low-pass, high-pass with negligible hum pickup, distortion and aging. Same eight cutoff frequencies, about 16 db attenuation per octave on both high and low.

send for bulletin S-1

DIVISION OF INTERNATIONAL RESISTANCE CO.

12970 BRADLEY AVENUE, SYLMAR 1, CALIFORNIA

# Ace can meet your requirements in quality and delivery of **NONLINEAR POTENTIOMETERS**

Nonlinear precision wire-wound potentiometers in standard and sub-miniature sizes are now available in prototype or production quantities from Ace Electronics Associates . . . and you can be sure of delivery.

These new Ace nonlinear units incorporate the same advanced engineering, precision craftsmanship, and controlled quality which have made ACEPOT linear potentiometers standards of excellence.

A new Division directed by highly qualified engineers, special prototype section, and mass production facilities are at your service to meet your requirements for quality and delivery of nonlinear precision potentiometers.

**For complete information . . .**

*Call or write William Lyon or Abraham Osborn, Nonlinear Division, outlining your requirements. Your inquiry will receive prompt attention . . . and you will get delivery as specified.*

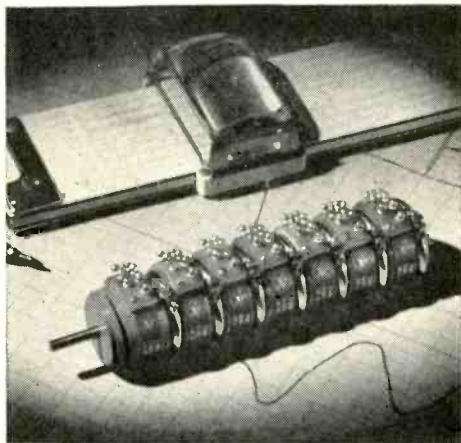

## Featuring!

*Highly developed design techniques achieve high resolution and close conformity for your unique nonlinear requirements.*

• trademarks applied for  
**ACEPOT\***  
**ACETRIM\*** **ACE ELECTRONICS ASSOCIATES, INC.**

Dept. E 101 Dover St. • Somerville 44, Massachusetts  
 Telephone: 50merset 6-5130 • Engineering Representatives in Principal Cities

*See the newest and latest at the Wescon Show Booth 2720*

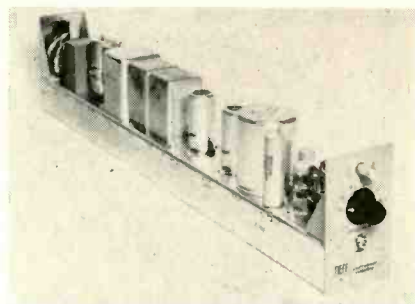

unique d-c amplifier featuring a true floating input is offered for amplification of low-level signals from thermocouples, strain-gage bridges, and resistance-bridge transducers. In the type 1-100C, input and output are isolated from each other and from ground. The amplifier, basically a carrier type, utilizes a 400-cycle chopper modulator.

The gain of this amplifier is continuously variable from 5 to 100 by means of a seven-position attenuator and a gain potentiometer. Linearity is 0.05 percent of full scale. Long-term stability is  $\pm 0.2$  percent of full scale, and long-term drift is less than  $\pm 5 \mu\text{v}$  referred to the input. Input impedance is greater than 1.5 megohms, and output impedance is 60 ohms. Noise level is less than  $5 \mu\text{v}$  peak-to-peak referred to the input. Circle 440 inside back cover.

## TRACER displays transistor curves

TEKTRONIX, INC., P. O. Box 831, Portland 7, Ore. This new precision instrument traces characteristic curves for both *pn*p and *np*n transistors on the face of a crt. It has a 10-ampere collector supply and a 2.4-ampere base supply. It displays 4 to 12 curves per family, with input current from 1  $\mu\text{a}$ -per-step to 200 ma-per-step, or input voltage from 0.01 to 0.2 volts-per-step.

Vertical deflection is calibrated in collector current, base voltage, base current and base source voltage. Horizontal deflection is calibrated in collector voltage, base voltage, base current, and base source voltage.

Seven different transistor characteristics are accurately plotted



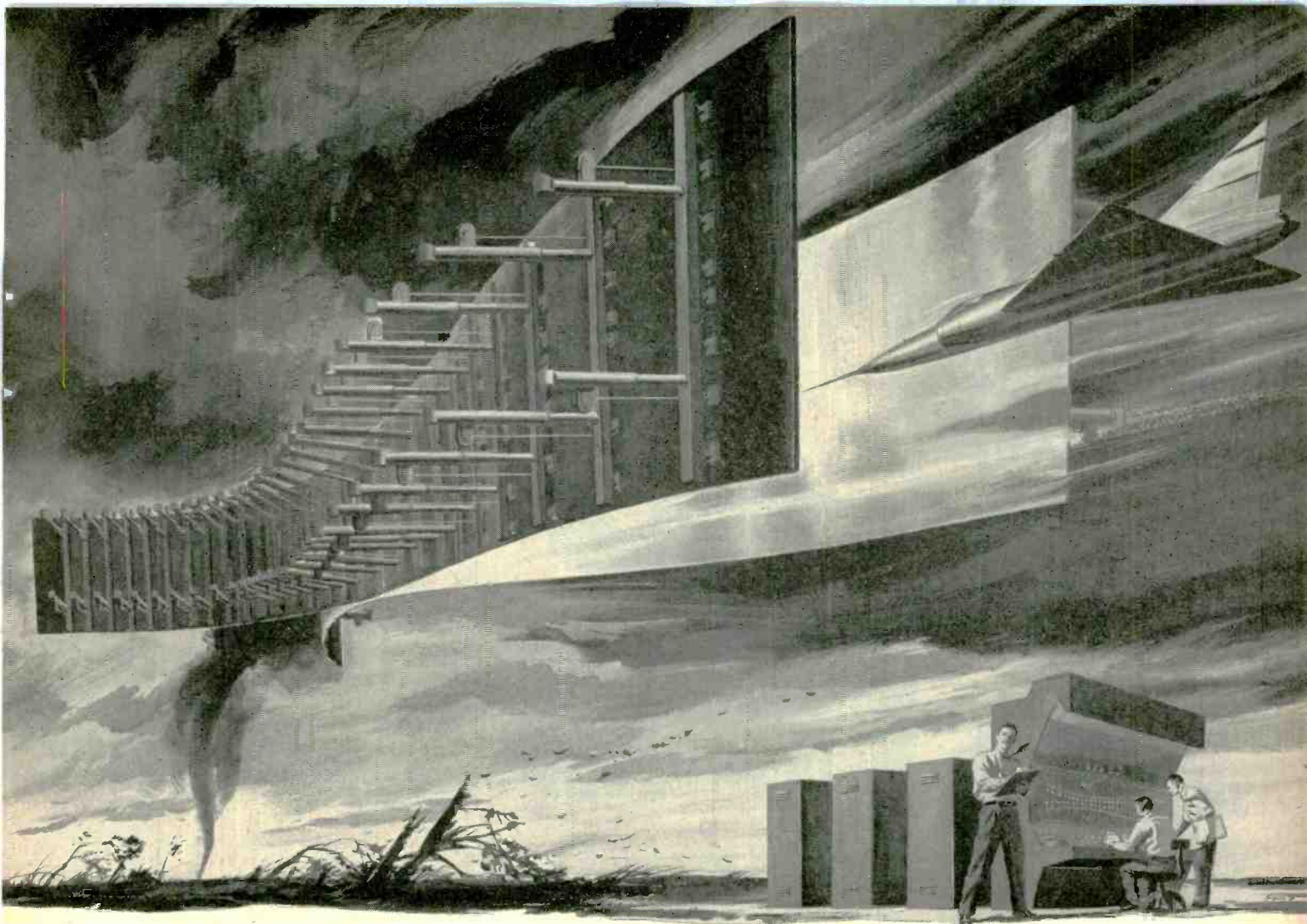

## Putting the screws on a tornado

The supersonic wind tunnel under construction at Tullahoma, Tennessee, combines some of the most gigantic construction with some of the most precise electronic controls in the whole history of aircraft testing.

The project simulates conditions of flight in excess of 16 miles altitude, from Mach 1.5 to approximately Mach 4.5. Some of the statistics of design are startling, even in today's world of wonders.

The nozzle walls of the tunnel are solid steel, 100 feet long, 16 feet high. To reach any one of 300 master positions, these plates are moved by 56 huge screw jacks on each side—with a tolerance for error restricted to 8 one-thousandths of an inch in an 8-foot stroke! Each jack "talks back" electronically to Master Control, reporting its position. Provision is made for remote starting and operation by magnetic tape programming, set up in advance.

Two associated companies are doing this job—the Electric Boat and Stromberg-Carlson divisions of General Dynamics Corporation. Electric Boat—

builders of the atomic-powered submarines, *Nautilus*, *Seawolf* and *Skate*—has overall responsibility, will supply the jacks and design the servo mechanisms. Stromberg-Carlson is to create and build the digital computer system for the electronic controls.

This project—combining heavy, giant-size, accurate "machinery" with electronic systems of a complex, automated nature—is typical of the service which General Dynamics divisions offer.

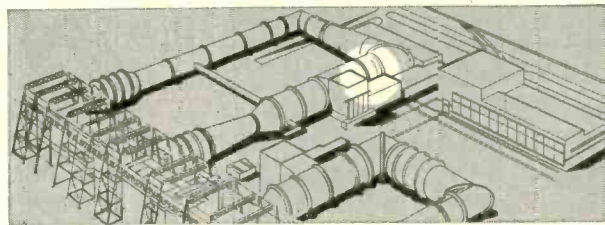

Sketch of the project, being built by the U.S. Army Engineers for the U.S. Air Force, Arnold Engineering Development Center. Circled area locates the special walls and nozzle.



### STROMBERG-CARLSON

A DIVISION OF GENERAL DYNAMICS CORPORATION

General Offices and Factories at Rochester, N. Y.—West Coast plants at San Diego and Los Angeles, Calif.





See how big 3-D views speed assembly, measurement and inspection of tiny parts.

# FREE 15-DAY, ON-THE-JOB TRIAL!

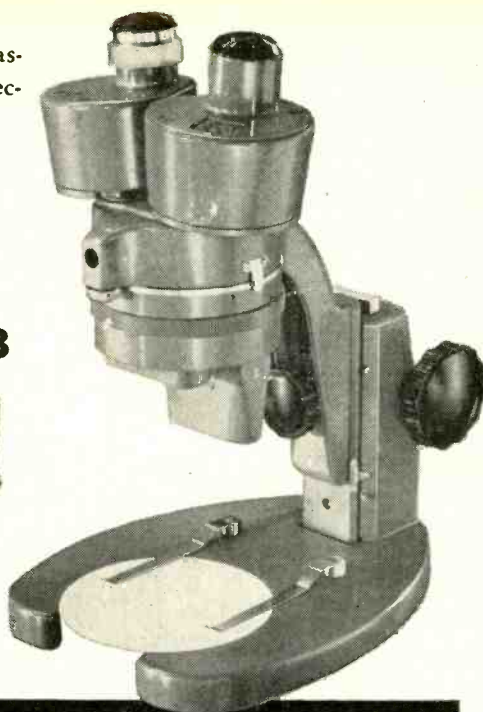

**Bausch & Lomb  
STEREOMICROSCOPES**

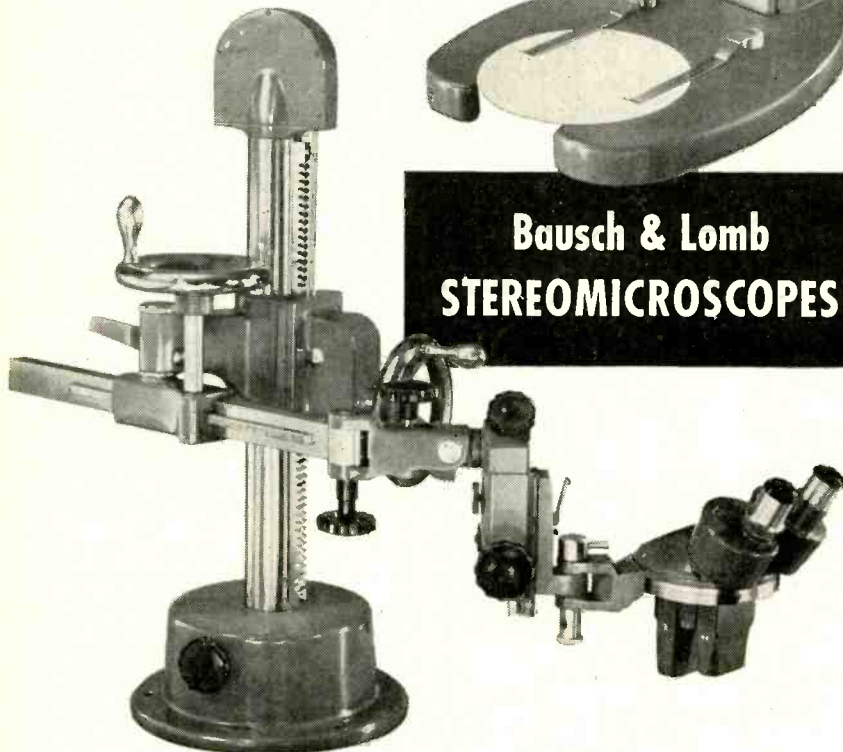

These essential production tools make small-parts manufacture faster and easier, make precision surer. Views are vivid, magnified in natural 3-dimensional detail. Complete line to fit exact model to your specific industrial needs. Dustproof, shockproof, built for rugged production-line use—you can mount them right on machines!

See for yourself! Use a B&L Stereomicroscope on your own job for 15 days—absolutely free, no obligation. All we ask is the opportunity to let our Stereomicroscopes prove themselves to you. Just call your regular B&L dealer, or mail the coupon today.

BAUSCH & LOMB OPTICAL CO.  
61420 ST. PAUL ST., ROCHESTER 2, N. Y.

- Yes, I'd like to borrow a B&L Stereomicroscope for a 15-day trial without cost or obligation.
- Send me B&L 3-D Micro-Vision Book, containing valuable data, showing actual stereo views.

NAME.....  
TITLE.....  
COMPANY.....  
ADDRESS.....  
CITY..... ZONE..... STATE.....

**BAUSCH & LOMB**



for examination and measurement. Sixteen dissipation-limiting resistances and 24 driving resistances are available. Single-family or repetitive display can be selected. Transistor characteristics can be displayed in either the common-emitter or common-base configuration. Price is \$925. Circle 441 inside back cover.

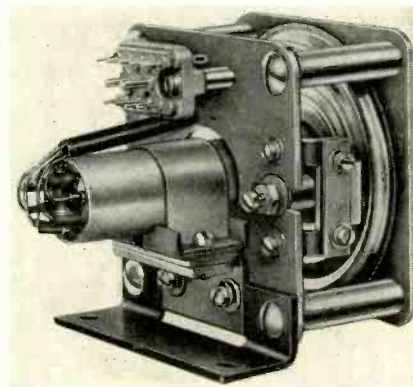

**PRESSURE TRANSDUCER**  
for data reduction systems

FISCHER & PORTER Co., 93 Jacksonville Rd., Hatboro, Pa., has developed a pressure transducer for use in data reduction systems. The device converts a 3-15 psi signal to a-c millivolts directly proportional to the pneumatic input. When pressure is applied to the sensing element of the transducer, the resulting movement of an expandable capsule displaces an armature which induces opposing voltages in twin secondary coils. This voltage is linearly proportional to the pressure input. The output may be used to po-



BURROUGHS CORPORATION... IS ANOTHER OF THE HUNDREDS OF IMPORTANT COMPANIES WHO DEPEND UPON PYRAMID FOR MANY OF THEIR CAPACITOR AND RECTIFIER COMPONENTS.

BURROUGHS CORPORATION

MR. EDWARD W. SCHENEG  
PLANT MANAGER  
BURROUGHS CORPORATION  
TIREMAN AVENUE PLANT  
DETROIT, MICHIGAN

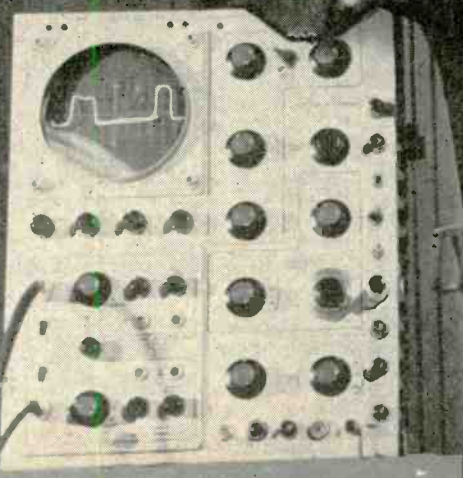

CAPACITORS—RECTIFIERS  
FOR ORIGINAL EQUIPMENT—  
FOR REPLACEMENT



**PYRAMID** ELECTRIC COMPANY

1445 HUDSON BLVD., NORTH BERGEN, NEW JERSEY





## CHICAGO STANDARD designs and builds both . . .

The choice of inductor type depends upon the frequency, the inductance, and on the space available in the specific application.

**Toroidal inductors** provide a significantly higher  $Q$  and lower loss in the frequency range above 500 cps. At inductances below 10 henries, toroids are relatively small and of low cost.

**Laminated inductors** have a higher  $Q$  and lower loss where frequencies below 500 cps are involved. At high inductances they are smaller and cost less than toroids.

Design engineers at Chicago Standard have extensive specialized experience with both toroidal and laminated inductors. In the design of Chicago Standard filters, they specify the type which will provide the optimum performance, in the smallest space, at the lowest cost. Full consideration is given to circuit requirements, characteristics of core materials, and physical limitations.

If you need a stock unit—or a special unit designed to your particular application—Chicago Standard can provide the most efficient solution to your problem.

**CHICAGO STANDARD  
TRANSFORMER CORPORATION**  
3502 ADDISON STREET • CHICAGO 18, ILLINOIS

Export Sales: Roburn Agencies, Inc., 431 Greenwich St., New York 13, N. Y.

sition an indicator, recorder or control device.

Accuracy of the F & P pressure transducer is high: 0.25 percent of the full scale. Additional information is available. **Circle 442** inside back cover.

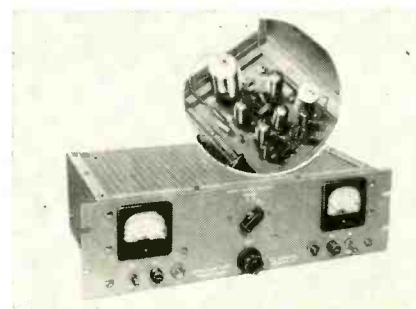

### SMALL POWER SUPPLY photomultiplier type

THE NJE CORP., 345 Carnegie Ave., Kenilworth, N. J., announces the availability of a new improved, miniaturized version of their photomultiplier power supply.

Printed-circuit techniques and completely redesigned circuitry have yielded the smallest, widest-range, best regulated supply currently available.

Designated the model CS-324XA, the unit supplies 800 to 2,000 v at 0 to 5 ma, regulated to  $\pm 0.005$  percent, against  $\pm 10$  percent line changes, with a load regulation of 0.035 v no-load to full-load, ripple less than 25 mv rms and excellent short-term stability. The new design occupies only  $5\frac{1}{4}$  in. of panel height on standard equipment. Model CS-324XA is reversible in polarity. It supersedes all the older photomultiplier power supplies formerly manufactured by the company. **Circle 443** inside back cover.

### R-F POWER MONITOR feed-through type

ELECTRO IMPULSE LABORATORY, 208 River St., Red Bank, N. J. This new feed-through r-f power monitor measures incident power between 2 and 500 mc; reflected power and vswr between 10 and 500 mc, in one compact instrument without any accessories. The instrument can be calibrated and



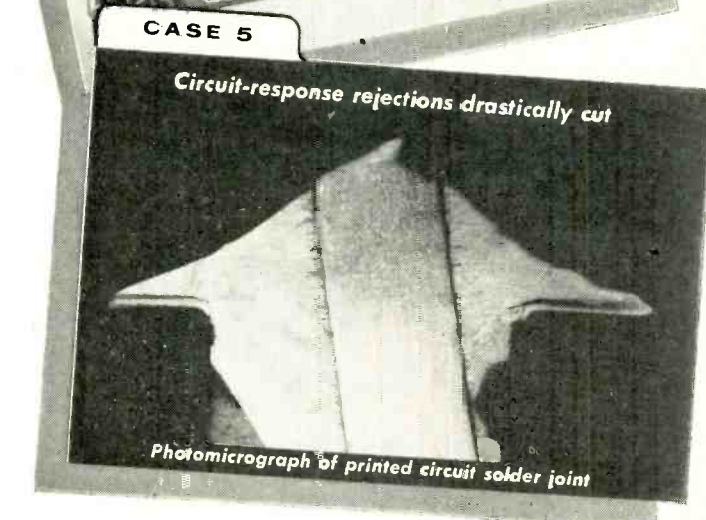
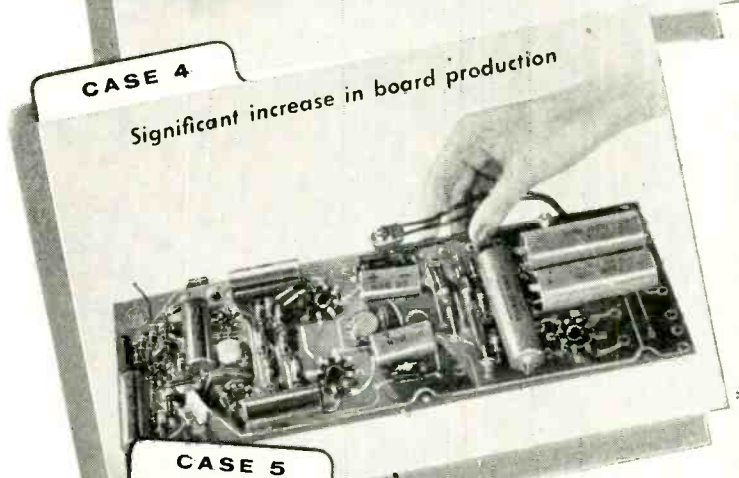
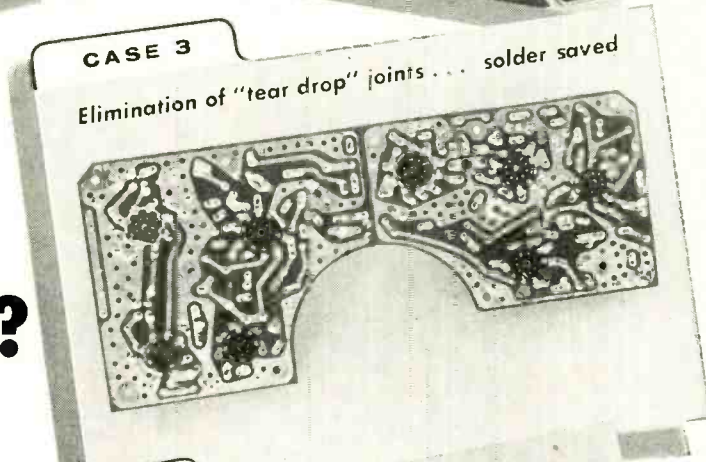
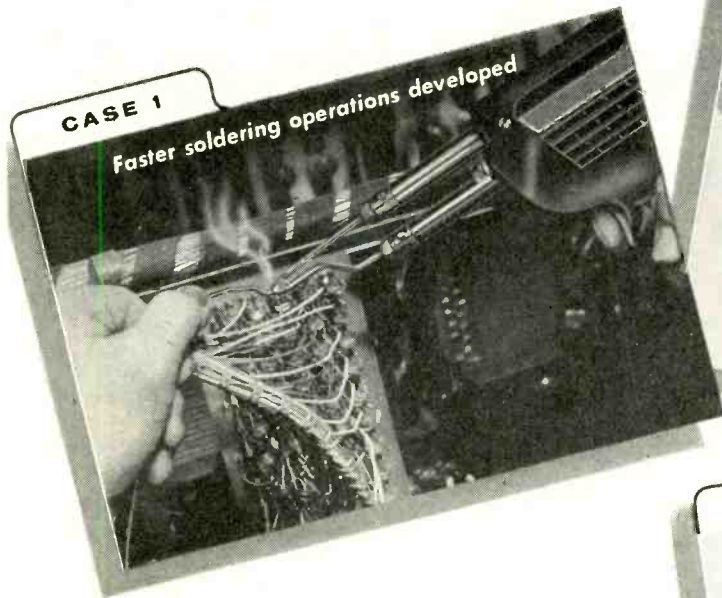

# How much is your "circuit printing" bill?

## Maybe "Dutch Boy" Solder Specialists can help you reduce it

"Dutch Boy" Solder Specialists have helped a number of companies look into the soldering phase of their "circuit printing" costs . . . and have come up with substantial savings.

### How have these savings been made?

Most of these savings have been made by very simple changes in flux or solder compositions or in operating conditions.

. . . A change in bath temperature. A switch to an activated non-conductive, non-corrosive flux . . .

In these and other ways "Dutch Boy" Solder Specialists cut "circuit printing" bills and boost production.

Maybe it would pay *you* to have a "Dutch Boy" Solder Specialist go over your soldering operations with an eye cocked for savings. Write NATIONAL LEAD COMPANY 111 Broadway, New York 6, New York.

Offices in Principal Cities

# Dutch Boy<sup>®</sup>

**SOLDER AND FLUXES**



# Now we can take care of the **BIG POWER** requirements

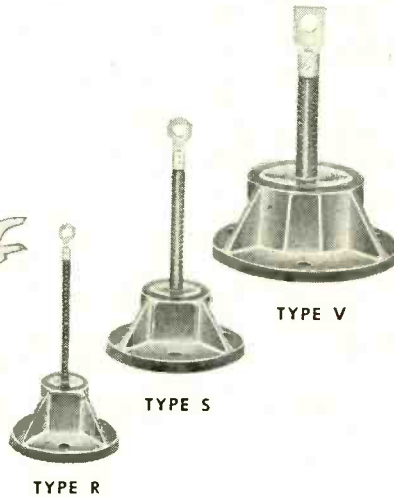
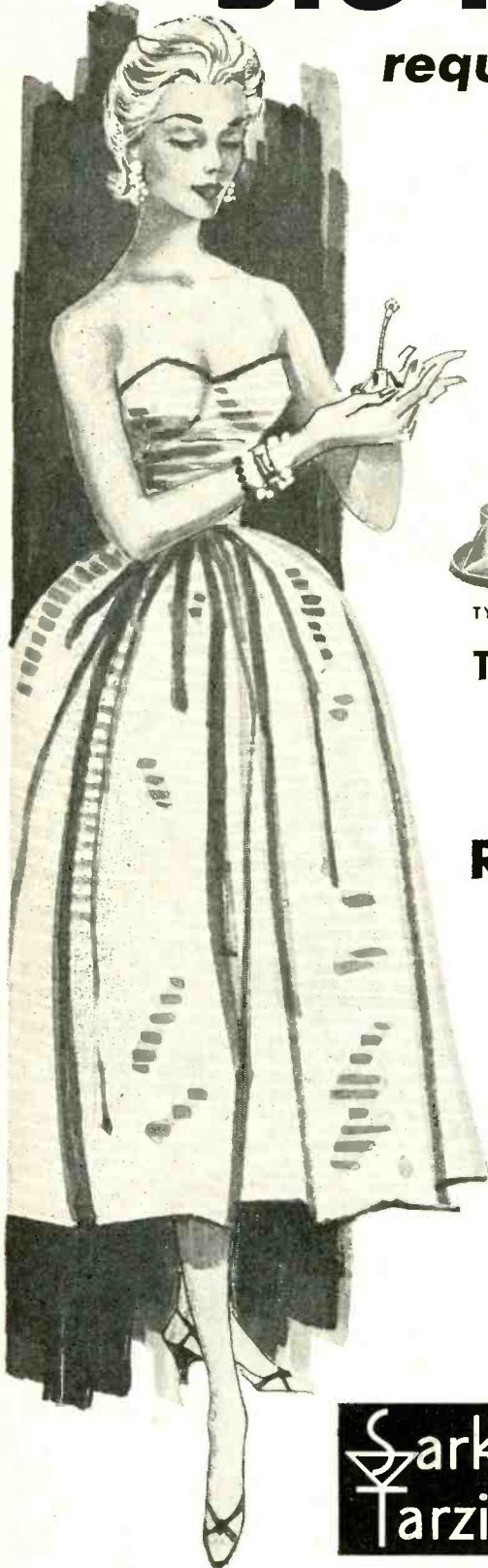

## Types R, S and V Sarks Tarzian **SILICON RECTIFIERS**

... have a voltage range from 50 to 300 volts peak inverse at current ratings of 20 amperes for the "R" series, 35 amperes for the "S" series and 100 amperes for the "V" series.

Positive or negative base polarities are available. Complete data sheets are available on request. Please write for information.

**Sarks  
Tarzian** INC.

**Rectifier  
Division**

DEPT. D-3 415 N. COLLEGE, BLOOMINGTON, IND.

IN CANADA: 700 WESTON RD., TORONTO 9, TEL. 2-7535 • EXPORT: AD AURIEMA, INC., NEW YORK CITY

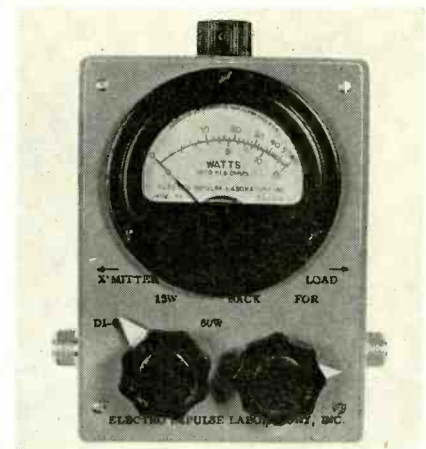

the calibration can be checked frequently at 60 cps with the help of an accurate 60 cps wattmeter. The power measuring range is 0 to 15 w, and 0 to 60 w. Similar instruments with higher power measuring ranges are also available. Circle 444 inside back cover.

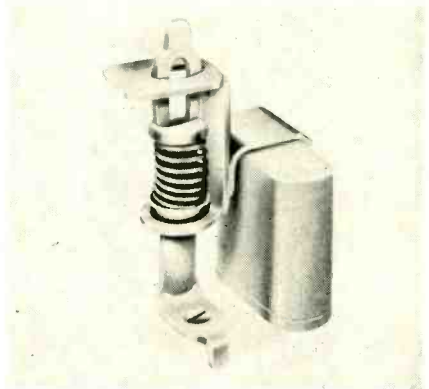

### **CRYSTAL CLIP** is easily chassis mounted

THE BIRTCHEP CORP., 4371 Valley Blvd., Los Angeles 32, Calif., has developed and produced a new line of crystal retainers. They are made from type 302 stainless steel and are designed to hold nearly all popularly used crystals, semiconductors and other miniature components having similar configuration securely in place under severe shock and vibration. Chassis mounting is accomplished through one screw or rivet and a drilled hole for a positioning tab. Removal of the crystal is effected through slight upward pressure on the spring-loaded retaining flange which swings completely out of the way to provide easy



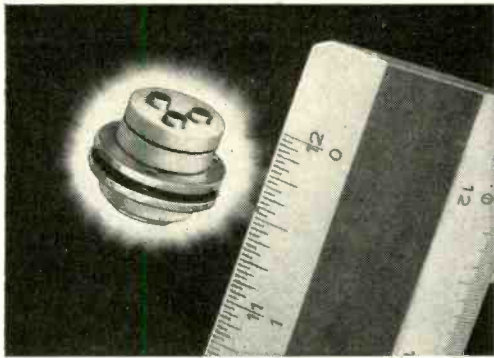

**ABOVE:** the GL-6917 voltage-tunable magnetron is extremely small and compact—only  $\frac{5}{8}$ " high and less than  $\frac{3}{4}$ " in diameter. **BELOW:** complete cavity and magnet assembly for the GL-6917 has been developed to assist equipment manufacturers.

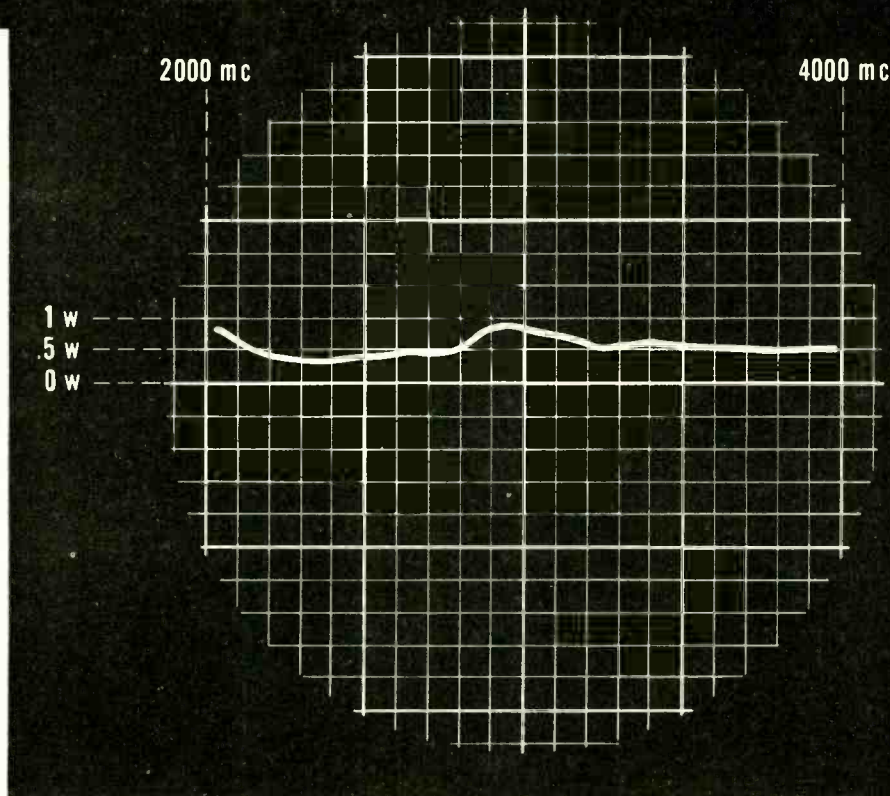
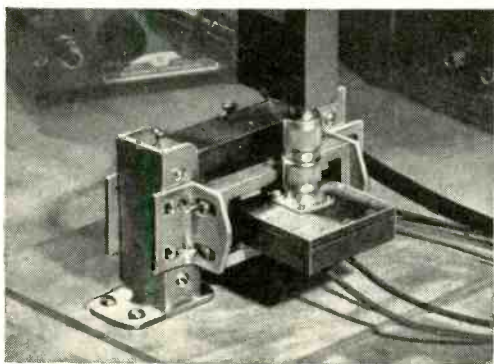

▲ Observe from the scope presentation above (actual photograph made with a production GL-6917 on test) how power over the entire 2000-mc tuning range is substantially constant, varying only .5 w. Because tube frequency, with voltage-tunable magnetrons, is a linear function of anode voltage, an r-f signal can be tuned at will to any frequency in a wide spectrum.

## New GL-6917 voltage-tunable magnetron combines wide-range tuning, steady output, dependability!

General Electric's GL-6917 voltage-tunable magnetron—first of a new series in development—offers to designers of military and other microwave equipment a simple, efficient means of changing output frequency rapidly with no important reduction in signal power.

The tube is a major breakthrough in circumventing enemy radar-jamming and in other counter-measure work. Also, the GL-6917 finds direct application in missile tracking and other telemetering . . . . in air navigation . . . . broadband test equipment . . . . microwave communications generally.

Construction is extra-rugged. Fundamentally compact and sturdy, the GL-6917 is a hard-solder type and is metal-ceramic for even greater strength. The tube is designed to operate unpressurized up to 60,000 feet altitude.

General Electric has developed a special cavity and magnet assembly for the GL-6917, to assist designers in applying the tube to equipment on the boards. For full information on Type GL-6917 and accessories, call your regional G-E power-tube representative! *Power Tube Department, General Electric Company, Schenectady 5, New York.*

*Progress Is Our Most Important Product*

**GENERAL**  **ELECTRIC**

9545-8481-1

access for service even in extremely crowded chassis. Circle 445 inside back cover.

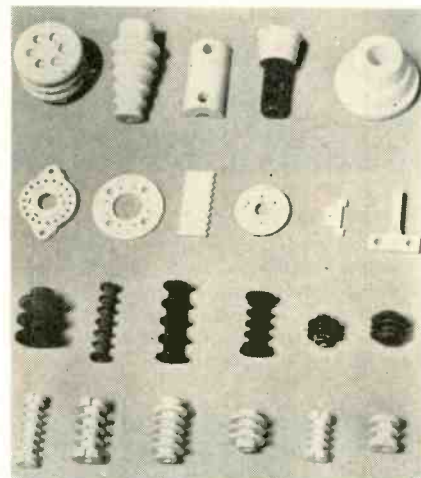

**BOBBIN LINE**  
custom fabricated

THOR CERAMICS, INC., 225 Belleville Ave., Bloomfield, N. J., offers a complete line of custom-fabricated winding forms, coil forms and bobbins. These bobbins, in addition to an unlimited variety of other shapes and sizes, can be made of epoxy, ceramics, nylon, polyesters, fluorocarbons, teflon, polystyrenes and other materials.

A large variety of standard or custom sizes and shapes of steatite, either pressed or machined, are also available to meet both JAN-1-10 and commercial specifications. Additional data is available. Circle 446 inside back cover.

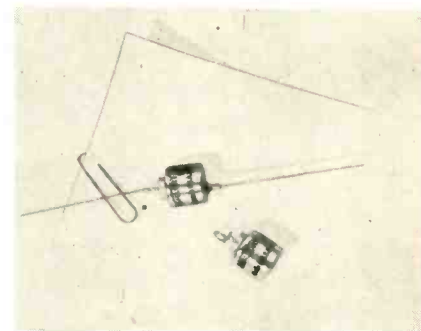

**TANTALUM CAPACITORS**  
designed for 175 C service

P. R. MALLORY & Co., INC., Indianapolis, Ind., has developed the XTM line of miniature tantalum electrolytics designed for 175 C

miniature  
encapsulated  
**PULSE**  
**TRANSFORMERS**  
by **TECHNITROL**

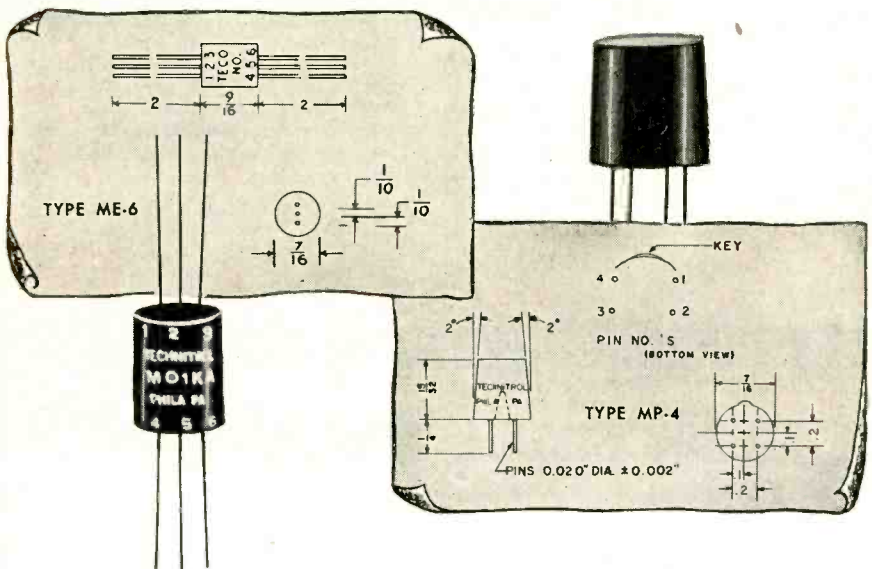

Wound on ferrite cores, the Type M series is available in a variety of windings to cover pulse widths from 2 microseconds down to .05 microsecond, wound inverting or non-inverting.

While the M series is particularly adapted to subminiature and transistor circuits, we design and build pulse transformers to fit specific circuits or to meet definite mechanical or thermal requirements, including MIL-T-27A.

Additionally, Technitrol makes a complete line of lumped and distributed parameter Delay Lines and a variety of electronic test equipment.

For additional information, write today for our bulletin

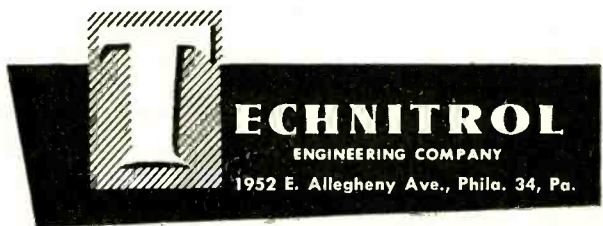



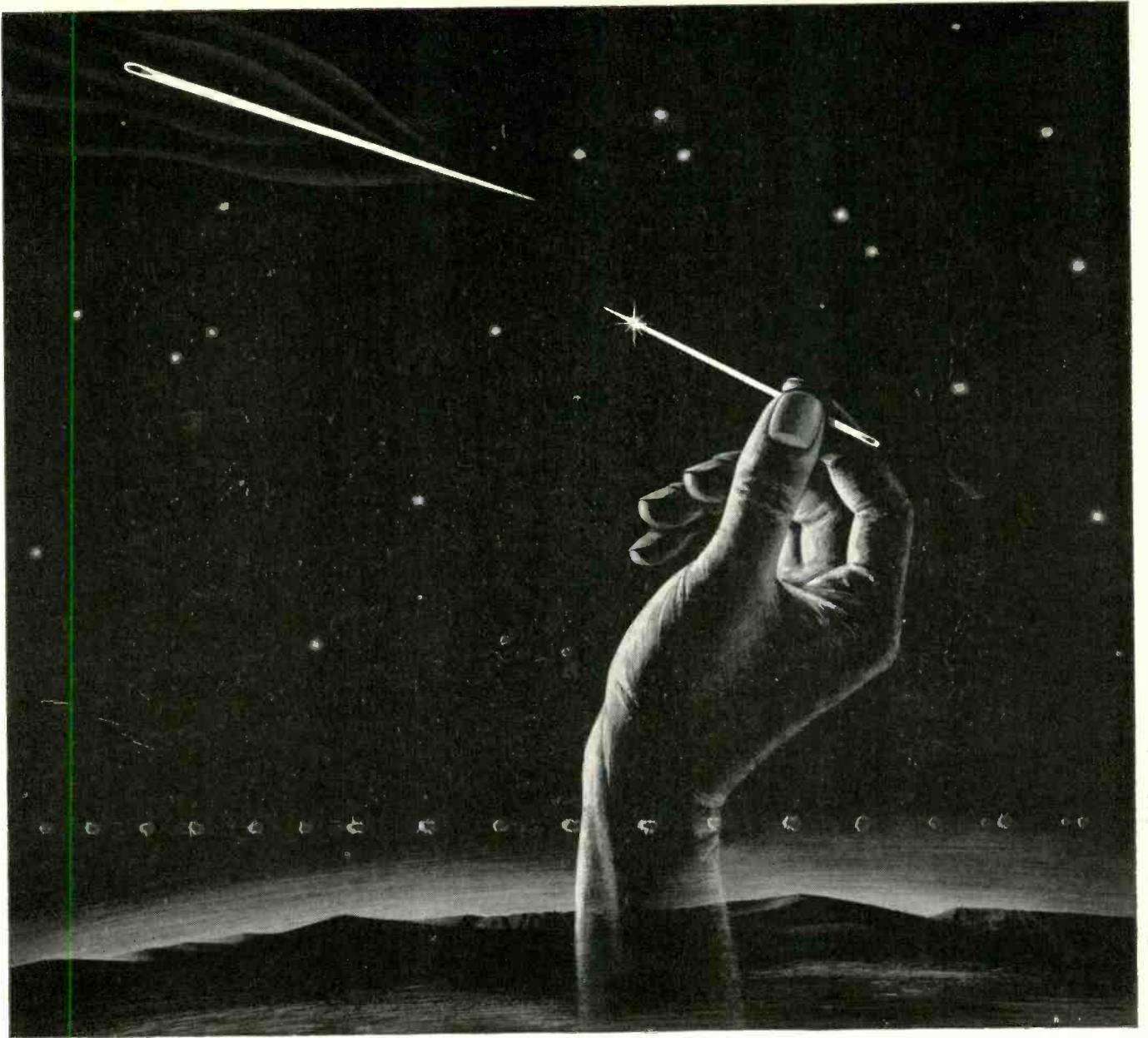

## *Sending a needle to intercept a needle...*

**T**HROW a needle high into the air. Then try to hit the needle by throwing another needle at it. You'll know how hard a task it is to intercept a deadly enemy "needle" rushing towards you from the sky at hypersonic speeds.

Engineers and scientists of

Sylvania's Electronic Systems Division are working to answer the threat of enemy ballistic missiles. Accepting complete responsibility, from idea to production, they are creating an integrated weapons system . . . a ground-to-air ballistic missile intercept system.

Whether your project requires management or technical experience for complex integrated systems, sub-systems, equipments or special components, from initial concept through mass production—Sylvania engineers will be glad to discuss methods of solving your specific problems.

SYLVANIA ELECTRIC PRODUCTS INC.  
Electronic Systems Division  
100 First Avenue, Waltham, Mass.



# SYLVANIA

LIGHTING • RADIO • ELECTRONICS • TELEVISION • ATOMIC ENERGY

# A New Broad Band **Kearfott**



Model  
W177-2C-1

## FERRITE ISOLATOR for Laboratory Test Bench Use

*Use this Ferrite  
Isolator in your  
microwave setup  
for maximum  
frequency stability.*

### Typical Performance Curves

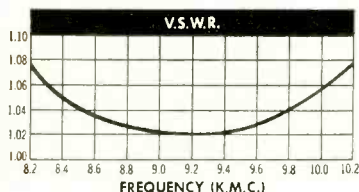
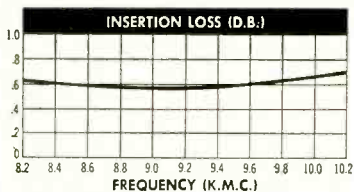
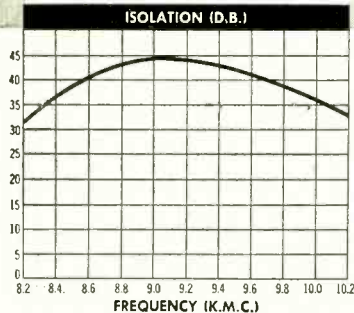

For detailed information, ask for bulletins on new Ferrite Isolators and Radar Test sets.



Eastern Office:  
1378 Main Ave.  
Clifton, N.J.

Midwest Office:  
188 W. Randolph St.  
Chicago, Ill.

South Central  
Office:  
6115 Denton Drive  
Dallas, Texas

Western Area  
Office:  
253 Vinado Ave.  
Pasadena, Calif.

**Kearfott COMPANY, INC.**  
LITTLE FALLS, NEW JERSEY  
**WESTERN DIVISION**  
MICROWAVE DEPARTMENT  
14844 OXNARD ST. - VAN NUYS, CALIF.

#### SALES OFFICES

South Central  
Office:  
6115 Denton Drive  
Dallas, Texas

Western Area  
Office:  
253 Vinado Ave.  
Pasadena, Calif.

### CHECK THESE FEATURES:

**Broad Band**—Usable from 8.2 to 10.2 KMC

**High Isolation**—A minimum of 25 db over the band

**Insertion Loss**—Less than 1 db

**Small & Compact**—Only 2½ inches long—weighs only 1½ lbs.

**Flanges**—Cover type. Mates with UG39/U flanges. Will absorb up to 10 watts reflected power

**Price**—\$135.00 each f.o.b., Van Nuys, Calif.

**Delivery**—From stock

**Order**—Model W177-2C-1

For custom-made isolators for specific radar & microwave application, you can depend on the skill of the Kearfott organization.

Kearfott, Western Division, has complete facilities for waveguide production, with qualified experts to assist in solving your problems. Let us help you.

service. They are intended for compact equipment where maximum conditions of temperature, humidity and mechanical shock are encountered.

The units are being manufactured in six capacitances, from 4 to 40  $\mu$ f, at nominal working ratings from 40 to 360 v. Of tantalum construction, these capacitors are designed for operation over a temperature range from -55 to 175 C. The body diameter of the metal case (all capacitances) is only  $\frac{5}{8}$  in., with case lengths from  $\frac{1}{8}$  in. to  $1\frac{3}{8}$  in. All capacitances employ a true metal-to-glass hermetic seal—offer a choice of 2¼ in. axial leads or solder-tab terminals. Circle 447 inside back cover.



### SILICON TRANSISTORS a new line of h-f type

TRANSITRON ELECTRONIC CORP., Melrose 76, Mass., has available a new line of high-frequency silicon transistors. Eleven types are included which provide a range of current gains up to 60, and collector voltage ratings to 45 v. Rated for operation to 175 C, these units feature low collector cutoff currents. All types are specified for a maximum of 0.5  $\mu$ a at their maximum collector voltage rating. Types ST13 and ST33 have a typical cutoff frequency of 17 mc.

Manufactured by the diffusion process, close control is maintained on all characteristics to achieve uniformity and interchangeability. All units are subjected to temperature cycling and storage, and other severe environmental tests to insure reliable per-



*For Leadership  
in Electrical Contacts Look to*  
**GENERAL PLATE**

Extensive new facilities are now completed and in operation at General Plate, offering customers a single source for an almost infinite selection of new and useful types and sizes of electrical contacts.

Here are but a few of the new ideas in contacts that have been developed commercially at General Plate.

- **Clad Electrical Contact Tapes** — designed for high speed mechanized assembly — ideal for miniaturization — give increased performance at reduced cost.
- **New Metal Bonding Processes** — offer improved contact materials — include silver cadmium oxides, refractory metal mixtures and platinum group metals, as well as all regular silver materials.
- **Trimetal Clad Projection Welding Contacts** — a copper conductor between contact face and backing — provides higher specific heat with lower surface temperatures — gives greater contact capacity and longer life at lower cost.
- **New Clad Button Projections** — designed and produced to meet your specific application requirements — facilitate easier welding, provide better conductivity.
- **New Silver Clad Rivets** — put silver where it is needed, with lower cost backing materials for better fastening properties.
- **Single and Double Inlay-Overlay-Top-lay** — made by G.P.'s new exclusive P.T. cladding process — achieves permanent bonding of preferred contact metals to practically any malleable base metal without intermediate bonding agents.

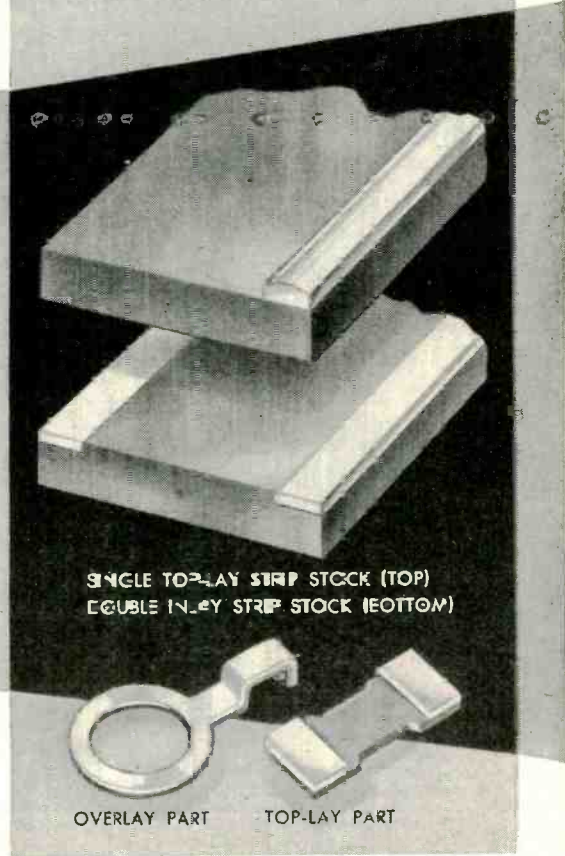
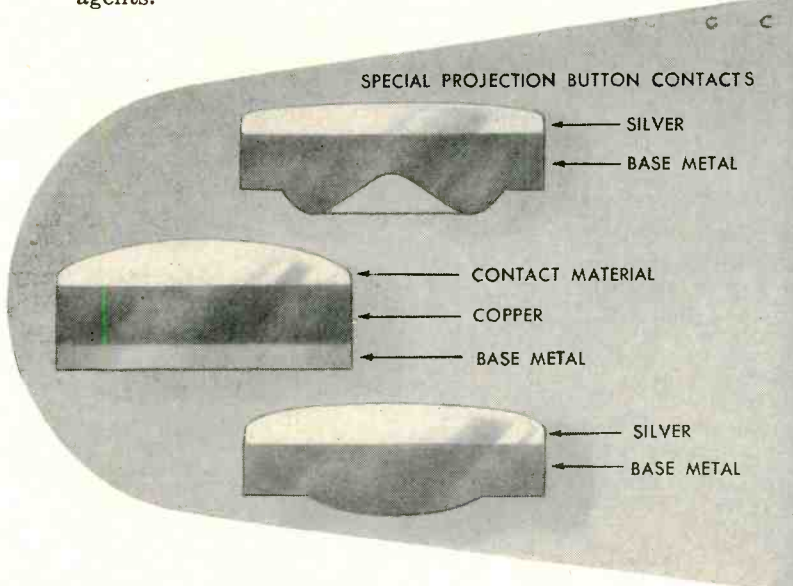
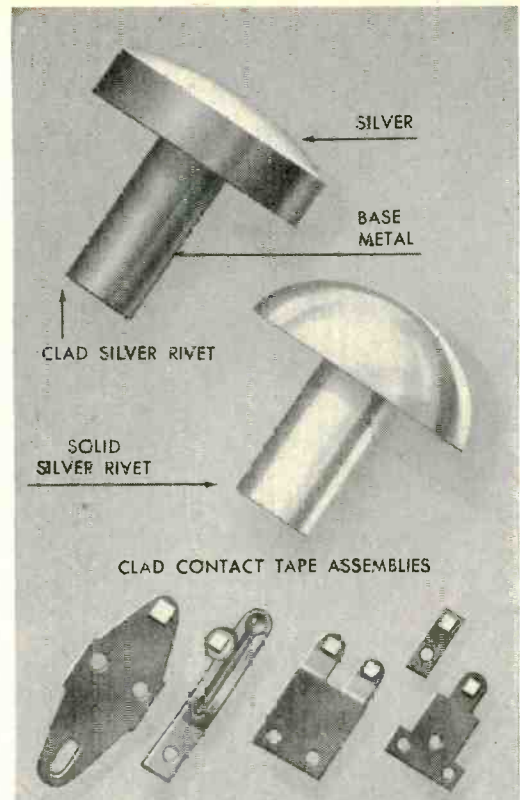

With 41 years of General Plate metal cladding experience behind the emphasis now being put on G.P. electrical contacts, it will pay you to investigate. Technical data bulletins are available on request — just let us know what types of contacts you are interested in.

*You can profit  
by using  
General Plate  
metals*

**METALS & CONTROLS CORPORATION**

*General Plate Division*

1308 Forest Street, Attleboro, Mass.

FIELD OFFICES: NEW YORK, CHICAGO, DETROIT, MILWAUKEE, LOS ANGELES

# SEE THEM ALL AT WESCON

EECO BOOTH

NO. 203

## NEW EECO SILICON TRANSISTOR PLUG-INS

*for extremely reliable ground  
and airborne equipment.*

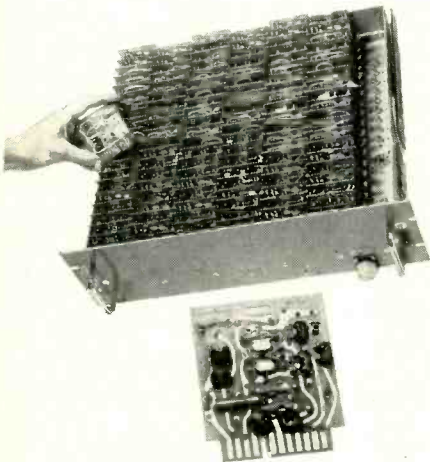

This is the first complete line of transistorized systems components offering hermetically sealed silicon semi-conductors and components.

Check these features:

- Operate reliably in ambient temperature range of  $-40^{\circ}\text{C}$  to  $+100^{\circ}\text{C}$ .
- Smaller, more compact (mounted on 2-7/8" x 2-9/16" x 1/16"-thick epoxyglass); still incorporating more components.
- Power supply requirements  $\pm 20$  Volts.
- Plug into any standard 12-contact etched-circuit connector.
- All plug-in contacts rhodium-plated for long life and trouble-free service.
- Complete supply of compatible systems hardware.

**CIRCUITS:** The complete line of EECO Silicon Transistor Plug-in circuits includes: FLIP-FLOPS • EMITTER FOLLOWERS • ONE SHOTS • SQUARING CIRCUITS • NEON DRIVERS • LINEAR AMPLIFIERS • RESET GENERATORS • BLOCKING OSCILLATORS • DIODE LOGICS • and many others.

### NEW EECO RUGGEDIZED STANDARD-SERIES PLUG-INS

The full line of tested and proven circuits available in EECO's Standard-Series Plug-ins has been ruggedized for even greater reliability and more efficient performance.

Each unit now incorporates the IERC Shield to:

- Protect tube from vibration and shock.
- Dissipate heat more effectively.
- Ensure longer tube life with cooler, more efficient operation.
- Provide even greater electrical shielding.

New mechanical construction and design assures full protection to critical components against stress or tension. All ruggedized units are compatible with EECO Standard-Series hardware and EECO Systems Development Racks.



**NEW CIRCUITS** include High-Speed Flip-Flops, Oscillators, etc., in both Computer-Series and Standard-Series Plug-ins... plus other systems building blocks: D-C Chopper Stabilized Amplifiers, Power Supplies and Compatible Accessories, Systems Development Racks, Systems Components. Detailed information available in Catalog No. 856-A. See them all at WESCON.

### ELECTRONIC ENGINEERS AND PHYSICISTS

— EECO offers immediate opportunities for qualified engineers in the transistor, amplifier, data-handling, pulse, timing, and systems-design fields. Inquire at Booth 203 or 1707. If you prefer, send a resume of your qualifications to R. F. Lander, Dept. ST.

formance in military applications. Bulletin TE-1353 provides complete specifications and ratings. Circle 448 inside back cover.

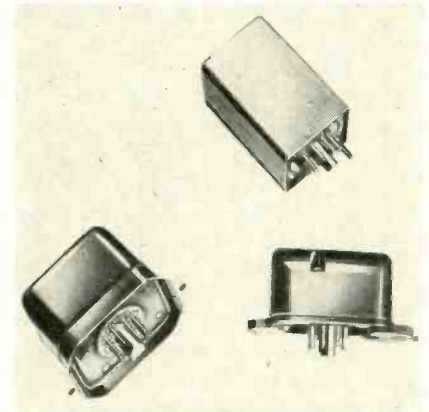

## D-C POLAR RELAY transistorized unit

BARBER-COLMAN Co., 1400 Rock St., Rockeford, Ill. The MYZA transistorized d-c polar relay is an adaptation of the company's Micropositioner with a built-in transistor preamplifier, requiring greatly reduced input power to operate the contacts.

MYZA units are available with three types of contact operation: form K or null-seeking calibration; form M, known as memory type calibration; and form C, snap-acting calibration. Three types of enclosures can be supplied.

These relays are useful in many positioning, variable leg Wheatstone bridge, and speed regulation circuits. They are designed to individual applications. Circle 449 inside back cover.

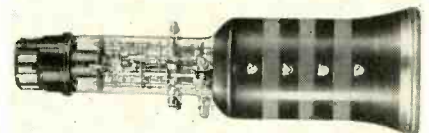

## DOUBLE-GUN CRT high deflection sensitivity

20TH CENTURY ELECTRONICS LTD.,  
King Henry's Drive, New Adding-

## ENGINEERED ELECTRONICS COMPANY



a subsidiary of  
Electronic Engineering Company of California  
506 EAST FIRST STREET • SANTA ANA, CALIFORNIA



Now—  
from AVNET

the new  
**HUBBELL**  
*Interlock*  
TRADE-MARK  
**SELF-LOCKING  
CONNECTOR**

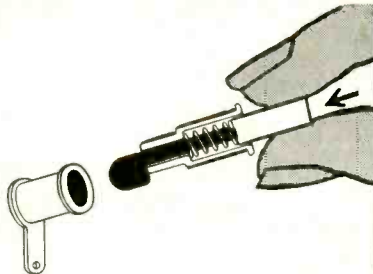

Grip mole Plug at extreme terminal end and push Plug straight into Jack.

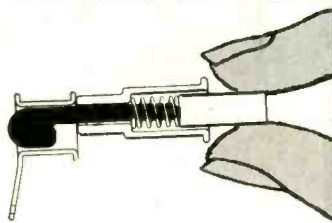

Contact head enters Jack.  
Sleeve is pushed back.

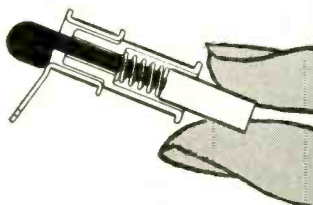

Contact head passes Jack tube and moves into offset position which allows front part of sleeve to center, snap in, and lock. Spring presses contact head against underside of Jack contact.

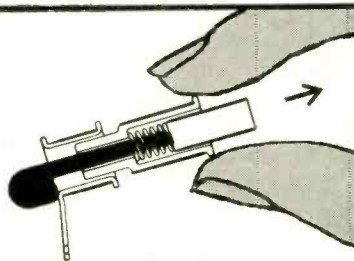

Pull on flanged sleeve lifts sleeve from tube and releases contact head. Plug then snaps out.

The HUBBELL INTERLOCK CONNECTOR is revolutionizing the Industry. The savings in time and in labor costs are almost unbelievable. Avnet Applications Engineers will give you more specific details. Phone, wire or write Avnet, East or West. See Avnet at the Wescon Show, Booth 107.



**Hubbell / Avnet**

AVNET EASTERN SALES:  
36 N. Moore St., N. Y. 13, N. Y.  
BEekman 3-5780

AVNET WESTERN SALES:  
.8966 National Blvd., L.A. 34, Cal  
TEXas 0-6141

Bendix • Sylvania • Thordarson • Sprague • Hubbell

	Fahnestock clip	Plug (banana)	Crimp	Wire Nut	Screw	HUBBELL INTERLOCK
1 Lg. Contact Area			✓	✓	✓	✓
2 High Contact force			✓	✓	✓	✓
3 Long life			✓	✓	✓	✓
4 Small size		✓	✓			✓
5 Mech. stability			✓		✓	✓
6 Quick disconnect	✓	✓		✓	✓	✓
7 Low assembly cost						✓
8 Self-burnishing						✓
9 Self-locking						✓

# IF VOLTAGE REGULATION IS A PROBLEM THIS MESSAGE IS DIRECTED TO YOU

Developments at Victoreen open up many new applications which heretofore have been restricted to complex, expensive, conventional methods of regulation due to high current requirements.

*Current ratings have been increased to as much as 4, 6 or even 8 ma in the new Victoreen corona regulators. These are produced for MIL and other applications in T6½ and T-9 envelopes in voltage ranges below 3500 v.*

They offer many opportunities to simplify circuits . . . to decrease complexity and costs . . . to provide a type of regulation never before available.

Our Applications Engineering Department is eager to help you out of your voltage regulation dilemma. A letter or call may solve your problem.

AA-5760

*ATTENDING WESCON? Be sure to see Victoreen's engineers. They'll be waiting for you at Booth 407.*

The  *Victoreen Instrument Company*

Components Division  
5806 Hough Avenue, Cleveland 3, Ohio

ton, Croydon, Surrey, England. Type D6AB/240 is a double-gun tube with a post deflection accelerating system suitable for operation at high ratios of screen to anode voltage. The gun itself is identical in characteristics to that used in the D6 series of tube, maintaining the features of high precision and high beam current. The configuration of the accelerating electrode minimizes the distortions associated with P.D.A. systems in a double-gun tube and allows the tube to be operated with a ratio of screen to gun voltage of 5 to 1, while keeping deflection nonlinearity to less than 3 percent. Deflector sensitivities at an overall voltage of 10 kv are 0.25 mm per v, giving a deflection sensitivity of one volt per spot width with a spot diameter of 0.25 mm.

The tube has a 6½ in. diameter, ground and polished flat face and is 19 in. long overall. For operation in the region of 10 to 20 kv aluminized screens are provided. **Circle 450 inside back cover.**



## TINY POWER SUPPLY is all transistorized

KAY ELECTRIC Co., 14 Maple Ave., Pine Brook, N. J., has introduced the Transiply which provides all the characteristics of an infinite life battery, and in addition, incorporates the flexibility of a continuously variable output voltage.

Special features include a stable metered output, continuously variable output, low impedance, no ripple, high current and avail-



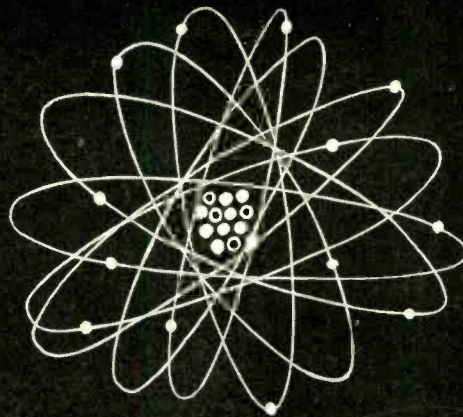

$$E = mc^2$$

## Atomic power in Caesar's day?

### *Certainly!*

It was there, in the ground, in the air and water. It always had been. There are no more "raw materials" today than there were when Rome ruled the world.

The only thing new is knowledge . . . knowledge of how to get at and rearrange raw materials. Every invention of modern times was "available" to Rameses, Caesar, Charlemagne.

In this sense, then, we have available *today* in existing raw materials the inventions that can make our lives longer, happier, and inconceivably easier. We need only *knowledge* to bring them into reality.

Could there possibly be a better argument for the strengthening of our *sources* of knowledge—our colleges and universities? Can we possibly deny that the welfare, progress—indeed the very *fate*—of our nation depends on the quality of knowledge generated and transmitted by these institutions of higher learning?

It is almost unbelievable that a society such as ours, which has profited so vastly from an accelerated accumulation of knowledge, should allow anything to threaten the wellsprings of our learning.

### *Yet this is the case*

The crisis that confronts our colleges today threatens to weaken seriously their ability to produce the kind of graduates who can assimilate and carry forward our rich heritage of learning.

The crisis is composed of several elements: a salary scale that is driving away from teaching the kind of mind *most qualified* to teach; overcrowded classrooms; and a mounting pressure for enrollment that will *double* by 1967.

In a very real sense our personal and national progress depends on our colleges. They *must* have our aid.

Help the colleges or universities of your choice. Help them plan for stronger faculties and expansion. The returns will be greater than you think.

If you want to know what the college crisis means to you, write for a free booklet to: HIGHER EDUCATION, Box 36, Times Square Station, New York 36, New York.



*Sponsored as a public service, in cooperation with the Council for Financial Aid to Education*

4 to 250 cfm

# MOTOR BLOWERS

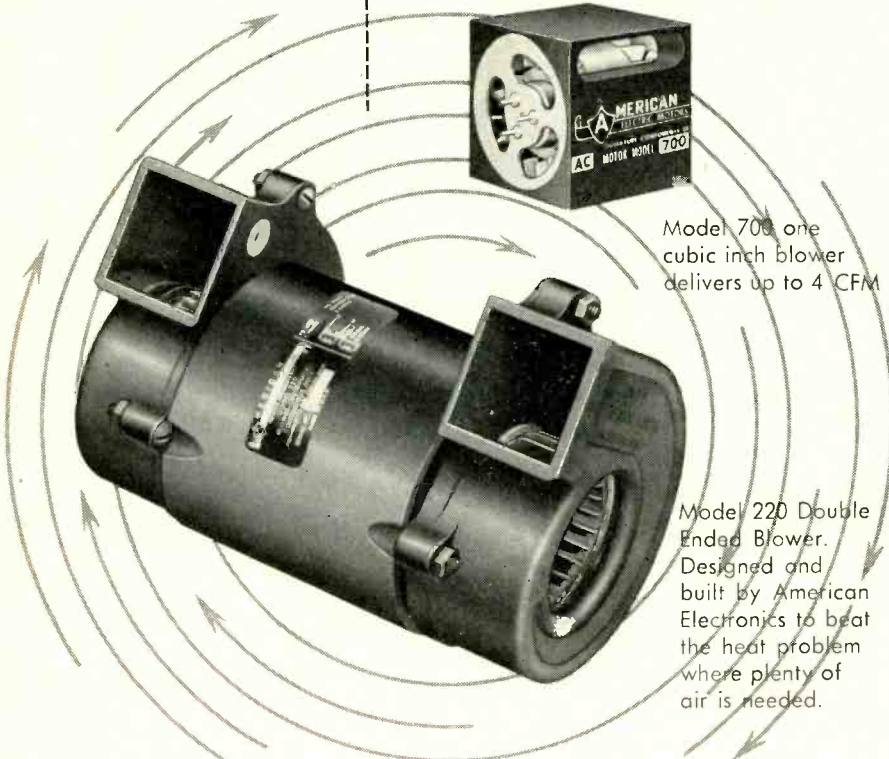

Model 700 one cubic inch blower delivers up to 4 CFM

Model 220 Double Ended Blower. Designed and built by American Electronics to beat the heat problem where plenty of air is needed.

Engineers . . . Exciting job opportunities in Southern California

American Electronics' engineers design motor blowers to meet problems, not just move air. And these engineers draw on the experience gained in years of producing motor blowers of every possible type and function. As a result, every design requirement is precisely translated to produce a light, compact unit that will do the job it was designed to do with maximum efficiency.

Ranging from 4 CFM to 250 CFM, American Electronics manufactures a complete line of DC and AC centrifugal blower and fan motor units for a wide variety of functions and applications. AC motor units are available in single or 3 phase at 115 v, 400 cycles. DC units from 12 to 230 volts. All meet pertinent Military Specifications.

Blowers for high back pressure applications or any other special requirements, custom designed and manufactured to specifications.

Write or wire Dept. 230A for specifications and complete information.

## AMERICAN ELECTRONICS, INC.

*Electro-Mechanical Division*  
655 W. Washington Blvd.  
Los Angeles 15, California



Other products manufactured by American Electronics include: AC and DC Miniature Motors; Gearmotors; Clutches; Brakes; Motor Alternators and Power Supplies; Electrical Ground Support Units; Air Conditioners; Resolvers; Servo Motors; Nuclear Instrumentations and High Fidelity Tape Recording Systems.

ability of positive or negative bias. Other features include small size, light weight, low heat loss, low noise, no hum, high conversion efficiency and elimination of warm-up time.

The unit may be used as a power supply for transistor circuitry, power supply to regulate filament and bias currents and as an infinite life battery.

Full specifications and prices are available from the company. **Circle 451 inside back cover.**

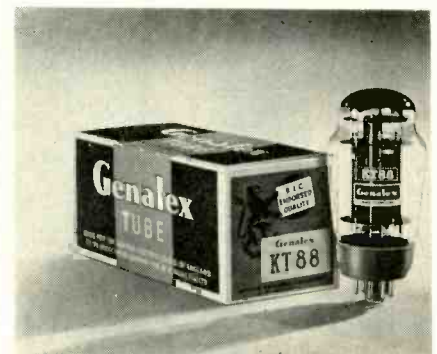

### AUDIO AMPLIFIER TUBE high power, low distortion

BRITISH INDUSTRIES CORP., 80 Shore Road, Port Washington, N. Y. The Genalex KT88 audio amplifier tube may be regarded essentially as a more powerful version of the KT66, with up to twice the output and even lower distortion. Yet it is considerably smaller than the KT66.

With fixed bias, an output of 100 w may be obtained from a pair of KT88 tubes with a plate supply of 560 v. The KT88 has the same pin connections as the 6L6 and KT66. It has an increased plate dissipation of 35 w, together with a higher mutual conductance based upon a cathode of more generous size. Its internal construction permits the use of a higher plate voltage. The KT88 fits the standard octal socket. **Circle 452 inside back cover.**

### VARIABLE RESISTOR for higher temperature

ALLEN-BRADLEY CO., 136 West Greenfield Ave., Milwaukee 4, Wisc. A new hot molded composition variable resistor, especially



designed to withstand ambient temperatures up to 150 C, has been added to the company's line.

Approximately one inch in diameter, the resistor is conservatively rated at 2 w under 100 C ambient operating conditions, and will provide reliable performance at a temperature of 150 C under "no load" conditions. Type K variable resistor has a conservative rating of 3 w for operation in 70 C ambient temperature.

The new control has the solid composition resistor element, terminals, insulation, faceplate, and threaded bushing all hot molded in a one-piece plastic body. This eliminates riveted, soldered and welded connections, which are potential sources of noise. After molding, the resistor is practically impervious to the effects of heat, cold, moisture and aging.

The resistors can be furnished in single, dual and triple units, with plain bushings or lock bushings. Shafts can be had plain, flatted or slotted in increments of  $\frac{1}{8}$  in. up to 6 in. maximum. **Circle 453 inside back cover.**

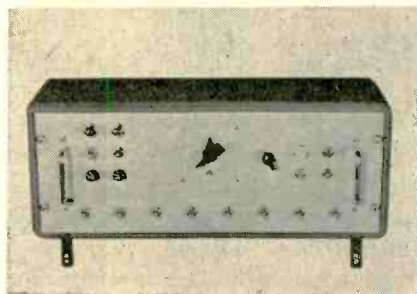

### PROGRAMMER for computer read-out

SANBORN Co., 175 Wyman St., Waltham 54, Mass. Operation of the company's six- and eight-channel oscillographic recording systems for analog computer read-out can now be automatically programmed, with a new device developed expressly for this purpose. Joint operation of the 156- or 158-5490 console system and the model 183 programmer occurs automatically in the following sequence (unless manually terminated)—step 1: recorder turned on; steps 2 to 16: calibration signal voltages of 0, 100, 20, 10, 5, 1, 0.2, 0, -0.2, -1, -5, -10, -20,

*What's going on up there?* 

### American Electronic's new 300 KC Band Width RECORDATA magnetic recording system gives an accurate, permanent record.

Specifically designed for recording data from satellites, missiles or other projects where extreme accuracy is required, RECORDATA offers a new concept in reliability and versatility. This sixteen channel system with its modular construction offers many unique features. For example, the six standard tape speeds of 1 $\frac{1}{8}$ , 3 $\frac{3}{4}$ , 7 $\frac{1}{2}$ , 15, 30 and 60 inches per second can be instantly selected with a single switch without changing belts or pulleys. Special speeds to 240 inches per second are also available. Automatic controls assure constant tape tension from beginning to the end of the reel, regardless of size.

Quickly interchangeable tape guides accommodate  $\frac{1}{4}$ "  $\frac{1}{2}$ " or 1" tapes. The plug-in magnetic head assemblies are extremely accurate and provide data tracks with the best electrical uniformity. Where fidelity and reliability are necessary in a data recording system you can depend on RECORDATA... manufactured by American Electronics whose Concertone Hi-Fi tape recorders have been famous as quality leaders. Write to Dept At36 for complete technical information

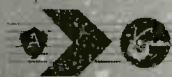
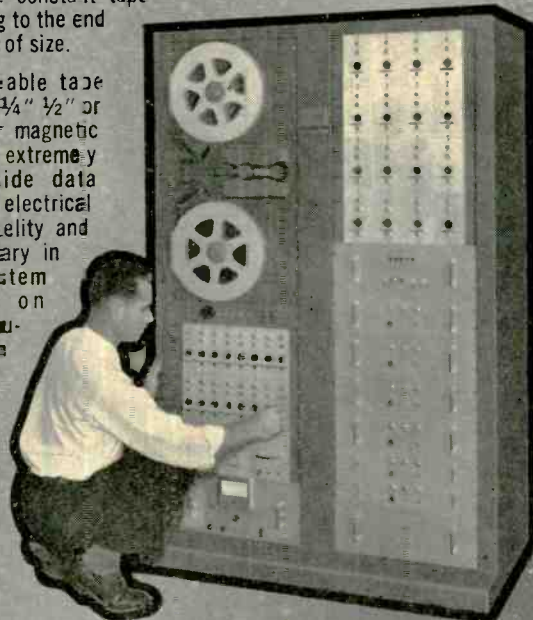

**AMERICAN  
ELECTRONICS  
INC.** 635 W. Washington Blvd.  
Los Angeles 15, California

*Have you heard about the wonderful Engineering opportunities at AMERICAN?*

Western Electric Equivalents

AVAILABLE AT **ADC**

The Western Electric Company has announced that they will no longer supply a number of their components to manufacturers. You are invited to make ADC your dependable quality source for these parts and to discuss your requirements for similar components with ADC.

**PLUGS**

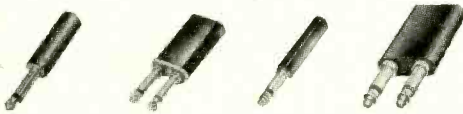

WE	ADC	WE	ADC	WE	ADC	WE	ADC
47	PJ5	241	PJ1	310	PJ3	213	PJ6

**JACK PANELS**



WE	ADC	ADC	WE	ADC
185	PJ31 PJ341	PJ33 PJ343	230A	PJ30 PJ340

**TERMINAL BLOCKS**

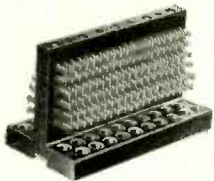

WE	ADC	WE	ADC
L3A	PJ103	L5A	PJ105
L4A	PJ104	L6A	PJ106

**JACKS**

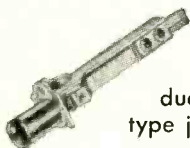

ADC offers equivalents for almost all 2 & 3 conductor long frame telephone type jacks.

**PATCH CORDS**

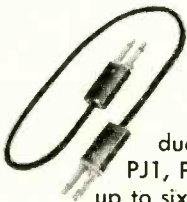

ADC can supply a variety of two and three conductor cords complete with PJ1, PJ3, and PJ5 plugs. Lengths up to six feet available from stock.

**COILS**



WE	ADC	WE	ADC
181B	A10129	307P 189D	A10127 A9100



WE	ADC
146A 146U	A10702 A10703



WE	ADC
23A	A9101



WE	ADC
240C	A9102

-100 and 0 fed to all channels; steps 17 and 18: d-c levels of computer read; step 19: computer output recorded for predetermined chart length, or as controlled by computer; step 20: recorder turned off, programmer reset for another cycle.

Cycle, initiated by a pushbutton, can be stopped and the programmer reset for another cycle at any time. Provision is also made for remote starting or stopping cycle. Length of record can be preset to any length up to 700 mm, or operated manually. Switches are provided for reversing the polarity of each individual input. **Circle 454 inside back cover.**

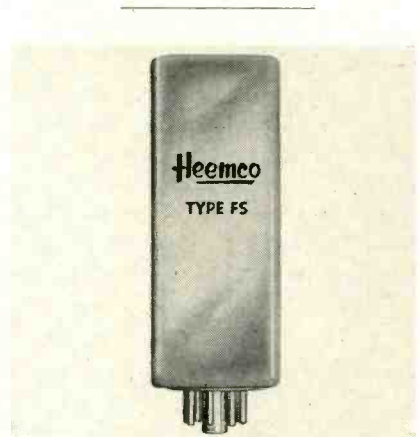

**PACKAGED SOURCES**  
for plug-in operation

HILL ELECTRONIC ENGINEERING AND MFG. CO., INC., New Kingstown, Pa. Shipped ready for plug-in operation on aircraft and missiles, these new small-size oscillators are designed for use without special shock mounting. They use quartz crystals for precise frequency control and are available in a range of from 400 cps to 150 kc.

This compact packaged source will maintain frequency stability and operation through vibration frequency of 0 to 2,000 cps at 10 g. A frequency stability of  $\pm 0.025$  percent can be maintained without oven over a range of -65 to 105 C and accuracies of  $\pm 0.002$  percent can be achieved over smaller temperature excursions. Use of an oven to control temperature will provide frequency stability of  $\pm 0.001$  percent from -65 C



**AUDIO DEVELOPMENT COMPANY**  
2838 13th AVENUE SOUTH • MINNEAPOLIS 7, MINNESOTA  
TRANSFORMERS • REACTORS • FILTERS • JACKS & PLUGS • JACK PANELS



to 95C under dynamic conditions of shock and vibration as given above with greater stability at lower temperatures.

It will meet specifications MIL-E-5272A, MIL-E-5400 and MIL-7-5422 for shock and vibration. Circle 455 inside back cover.



### FREQUENCY CONVERTER weighs only 3½ lb

THE LIQUIDOMETER CORP., Skillman Ave., 36th & 37th Sts., Long Island City 1, N. Y., has announced a new frequency converter that makes 400-cycle power available at any 60-cycle electrical outlet. Overall dimensions are 8½ by 5 in. and weight is 3½ lb. The long-life design and sturdy construction of the converter make it practical for continuous use in the small shop or laboratory, or as a secondary 400-cycle power source in the larger instrument shop.

The frequency converter has no moving parts, is quiet in operation and supplies up to 20 w power output. Bulletin number 629 supplies complete information. Circle 456 inside back cover.

### BALLISTIC COMPUTER displays seven parameters

ALEGANY INSTRUMENT CO., INC., 1091 Wills Mountain, Cumberland, Md. Type K-1 ballistic computer is used in the development of guided missiles. It contains all necessary amplifiers, programming circuitry and balance equipment for direct hookup to the thrust and pressure transducers, and automatically displays such

# Now —

## NO plate too small — 213B

## NO panel too big

# NO size limits on engraving

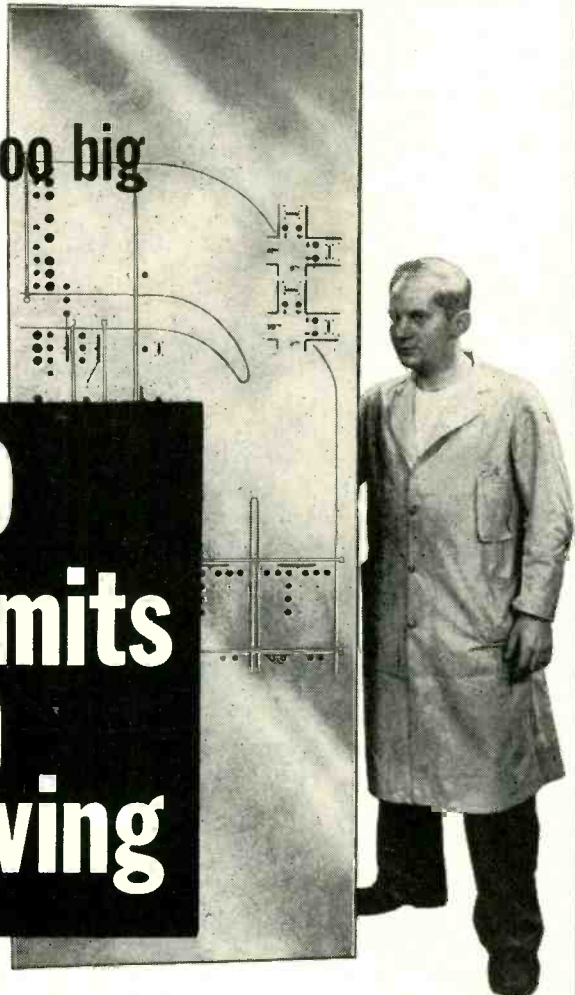

The new ENGRAVOGRAPH Model I-R takes up only 2 feet of bench space and engraves anything from tiny nameplates to giant panels. Engraving chassis can be detached from base and placed directly on workpiece of any dimension. Smaller plates can be easily clamped in a self-centering workholder which is standard equipment.

New sturdy pantograph construction; heavy duty cutter spindle; two-way depth regulator.

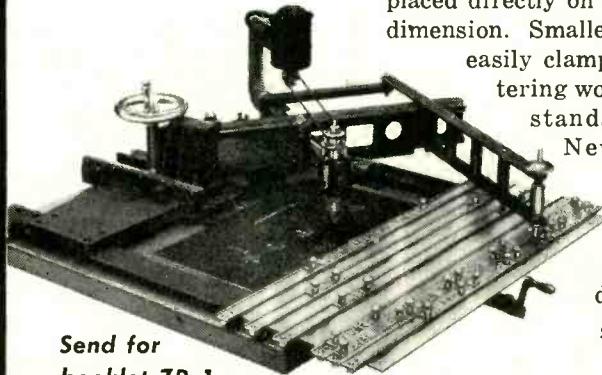

Send for  
booklet ZR-1

See demonstration at  
Booth #2904  
Wescon Show

## new hermes ENGRAVING MACHINE CORP.

13-19 University Place, New York 3, N.Y.

# TELEPHONE AND TELEGRAPH EQUIPMENT

Radio Engineering Products is currently producing a number of types of equipment, electrically and mechanically interchangeable with standard Bell System apparatus.

## CARRIER-TELEPHONE EQUIPMENT

C5 Carrier-Telephone Terminal (J68756). A kit for adding a fourth toll-grade channel to existing C systems is available. • C1 Carrier-Telephone Repeater (J68757) • 121A C Carrier Line Filter • H Carrier Line Filter (X66217C).

## CARRIER-TELEGRAPH EQUIPMENT

40C1 Carrier-Telegraph Channel Terminal (J70047C) • 140A1 Carrier Supply (J70036A1, etc.) • 40AC1 Carrier-Telegraph Terminal.

## VOICE-FREQUENCY EQUIPMENT

V1 Telephone Repeater (J68368F) • Power Supply (J68638A1) • V1 Amplifiers (J68635E2 and J68635A2) • V3 Amplifier (J68649A) • V-F Ringers (J68602, etc.) • Four Wire Terminating Set (J68625G1) • 1C Volume Limiter (J68736C).

## D-C TELEGRAPH EQUIPMENT

16B1 Telegraph Repeater (J70037B) • 10E1 Telegraph Repeater (J70021A) • 128B2 Teletypewriter Subscriber Set (J70027A).

## TEST EQUIPMENT

2A Toll Test Unit (X63699A) • 12B, 13A, 30A (J64030A) and 32A (J64032A) Transmission Measuring Sets • 111A2 Relay Test Panel (J66118E) • 118C2 Telegraph Transmission Measuring Set (J70069K) • 163A2 Test Unit (J70045B) • 163C1 Test Unit (J70045D).

## COMPONENTS AND ACCESSORIES

255A and 209FG Polar Relays • Repeating and Retard Coils, several types • 184, 185, 230A and 230B Jack Mountings.

NEW PRODUCTS

(continued)

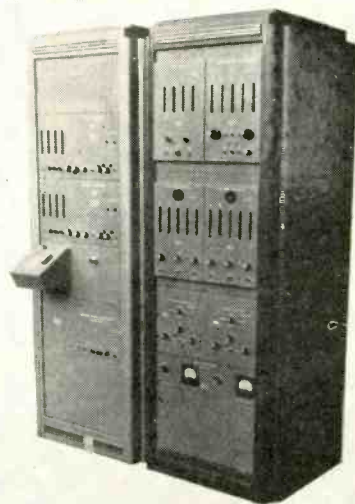

parameters as ignition delay, action time, integrals of thrust and pressure as well as peak values.

The K-1 can be supplied either for printout on paper tape by a Clary printer or on cards by IBM summary card punch. It is also available as the type K-2 which contains special tape recording equipment and a highly refined play-back analyzer section for detailed examination of isolated portions of a record. Circle 457 inside back cover.

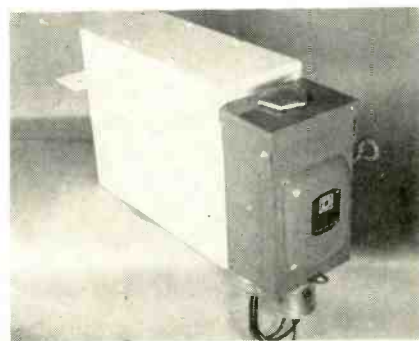

## BROADBAND PREAMPS with low noise

A R & T ELECTRONICS, INC., P. O. Box 370, North Little Rock, Arkansas has available a line of low-noise preamps with frequency ranges from 53 mc to 470 mc. A typical preamp, model A 195-42, has a 3 db bandwidth of 163 mc to 227 mc, midband gain of 12 db and midband noise-figure of 2.0 db.

These fixed-tuned broadband preamps are designed for continuous unattended operation mounted at the antenna and con-

## RADIO ENGINEERING PRODUCTS

1080 UNIVERSITY ST., MONTREAL 3, CANADA

TELEPHONE

UNiversity 6-6887

CABLES

RADENPRO, MONTREAL

Circle 214 Readers Service Card

# BEEDE Electric Meters

**NOW**  
**3 sizes**  
IN CRYSTAL CLEAR  
STYRENE CASES

MODEL 14  
3 3/8" x 3"

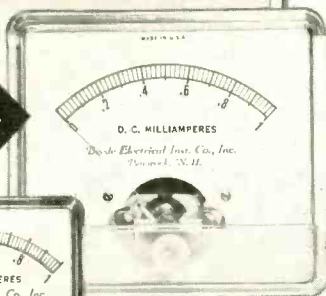

MODEL 2 PL  
2 3/8" x 2 3/8"



MODEL 23  
4 5/8" x 4 3/16"

The same —  
high quality, durability and  
accuracy for which BEEDE  
Electric Meters have long  
been recognized.

WRITE FOR CATALOG

**BEEDE ELECTRICAL INSTRUMENT CO., INC.**  
**PENACOOK, N. H.**



nected to the receiver by low-loss coaxial cable. Rack mounting models are available.

Power consumption is 15 w at 110 v, 60 cps. A fused switch box with pellet-type lightning arrestor is provided.

The preamps are designed for input and output impedances of 50 ohms. The input circuits are mismatched for optimum noise figures. Preamps for other impedances are available on special order.

One W.E. 416B planar triode and two selenium rectifiers are used. The rectifiers are on a separate chassis with plug-in interconnections.

The metal case is 10 in. high by 16 in. wide by 5 in. deep and mounts by means of two right angle mounting brackets. Weight is 23 lbs. Circle 458 inside back cover.

## AUDIO PREAMPLIFIER with high-speed agc

ELECTRONIC SYSTEMS ENGINEERING Co., 903 Cravens Bldg., Oklahoma City, Okla., announces the Lim-pander (limiter-expander) model LE-2, audio preamplifier with new high speed, non-feedback, automatic gain control that incorporates a unique background noise squelching system. High impedance input, and outputs at low level as well as 600 ohms (high level), facilitates easy incorporation in existing installations. Limiter portion of the amplifier has a time constant of 50  $\mu$ sec on attack and 20 millisecc on release. Consonant amplification is accomplished without the excessive distortion of clipper circuits.

Model LE-2 is especially useful as a consonant amplifying preamplifier for plant paging systems. The noise penetrating characteristics of consonant amplified sound makes a paging system more effective.

Audio monitoring for plant protection is greatly facilitated by the high speed squelch of the lim-pander, model LE-2. It provides an effective means of eliminating the normal background noise of any large room such as a warehouse,

The **Size**  
**Type**  
**Rating**  
**Quality**

to meet your  
most exacting  
requirements



# Twist-Lock®

Illustration, below, shows size relationship of a Hubbell 4-wire, 50 amp. Twist-Lock cap and a midget 2-wire, 10 amp. Twist-Lock cap . . . a good indication of the wide range of sizes and ratings available to product engineers and designers of electrical equipment.

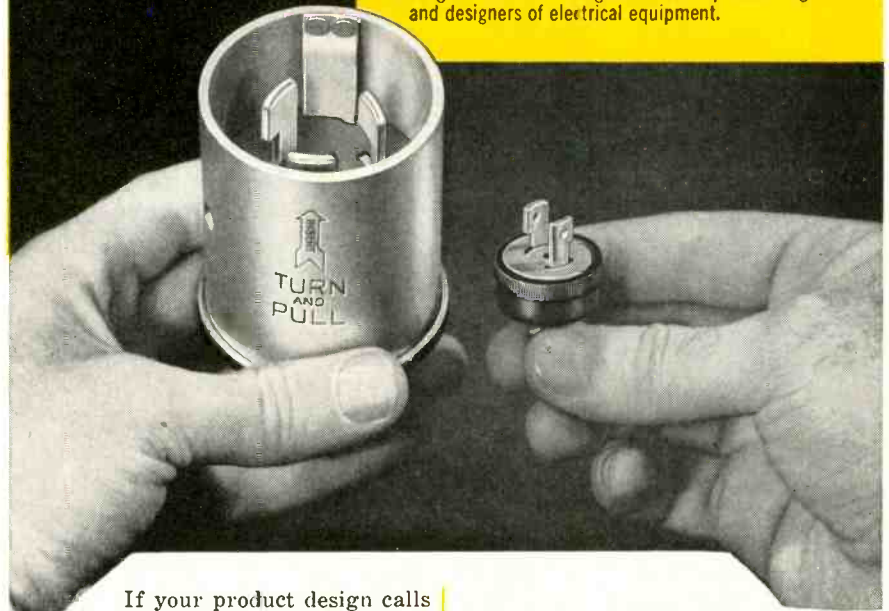

If your product design calls for a lock-type electrical connection, "Twist-Lock" by Hubbell represents the finest, safest and most complete line ever developed. Caps, connector bodies, motor bases and receptacles are available in a wide variety of types and sizes, and in the ratings to conform to your electrical specifications.

Every cap and connector body from 10 amp. to 50 amp. is now available with "Seal-Tite" rubber covers for weatherproofing purposes, protection from dust and dirt or from hard knocks and rough usage.

"Seal-Tite" Rubber Covers for the complete line of "Twist-Lock" caps, cord connectors and male and

female flush receptacles are recommended wherever moisture or breakage is a problem. Rubber closure plugs are also available for most "Twist-Lock" male and female receptacles.

### "SEAL TITE" RUBBER COVERS

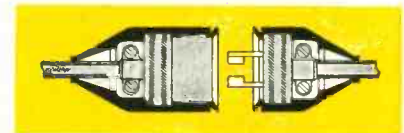

"Seal-Tite" Rubber Covers feature a "bellows" action which effectively seals out moisture, oil, dust, dirt, lint, metal chips, etc. There is a "Seal-Tite" rubber cover or closure to fit every "Twist-Lock" device.

Write for 4-pg. brochure presenting the complete "Twist-Lock" Line.

# HARVEY HUBBELL, INC.

HIGHEST QUALITY  
WIRING DEVICES • MACHINE SCREWS

DEPT. D BRIDGEPORT 2, CONNECTICUT

WIRING DEVICE  
WAREHOUSE LOCATIONS  
ASSURE NATIONWIDE  
STOCK AVAILABILITY

Bridgeport 2, Connecticut  
State and Bostwick Streets  
Chicago 7, Illinois  
37 South Sangamon Street  
Los Angeles 12, California  
103 North Santa Fe Avenue  
San Francisco, California  
1675 Hudson Avenue  
Dallas 7, Texas  
1111 Dragon Street

# FANSTEEL

## STA

### SOLID

### TANTALUM

# CAPACITORS



#### Here Are The Sizes Available

	CATALOG NUMBER	CAPACITY IN MFD*	WORKING VOLTAGE	SURGE VOLTAGE
100 SERIES	STA-155	3.5	10	12
	STA-160	2.0	15	18
	STA-165	1.5	20	24
	STA-170	1.2	30	36
	STA-175	1.0	35	42
200 SERIES	STA-255	17	10	12
	STA-260	11	15	18
	STA-265	8	20	24
	STA-270	6	30	36
	STA-275	5	35	42
300 SERIES	STA-355	70	10	12
	STA-360	45	15	18
	STA-365	35	20	24
	STA-370	23	30	36
	STA-375	20	35	42

\*Standard Capacity Tolerances are minus 15%, plus 25%.

NOW AVAILABLE IN PRODUCTION QUANTITIES



Write for bulletin 6.112

FANSTEEL METALLURGICAL CORPORATION

North Chicago, Illinois, U. S. A.

SEE US AT WESCON Booth Nos. 1221-1222

NEW PRODUCTS

(continued)

yet will transmit at high gain all transient sounds. Circle 459 inside back cover.

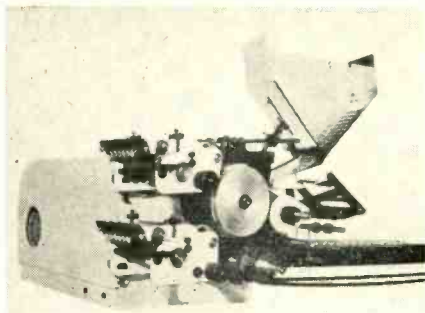

#### MARKING MACHINES two new models

POPPER & SONS, INC., 300 Fourth Ave., New York, N. Y. Two marking machines entirely new in design and performance have been added to the line of Rejafix marking equipment. These machines can be used to mark resistors, capacitors, tubes and the like.

One is the fully automatic model 555 (illustrated) which will print in one or two colors onto cylindrical items of limited diameter size at a speed of about 6,000 to 9,000 pieces. It prints directly or by off-set.

The other machine is the semi-automatic model Four Square which will print in one or more colors onto products of many shapes, including flat and tubular ones. Circle 460 inside back cover.



#### AXIAL FLOW FANS feature Venturi ring mounts

ASHLAND ELECTRIC PRODUCTS, INC., 32-02 Queens Blvd., Long Island City 1, N. Y., has available a new series of 4-in., 8-in. and 10-in. axial flow fans. These propeller fans come complete with Venturi rings facilitating direct mounting against enclosures, cabinet walls or dust filter boxes without the



additional cost and bother of further rings and brackets.

These fans are available for 50, 60 or 400 cycle operation, or for variable power supply frequencies; and for all voltages and phases. Designed for military or commercial requirements, the precision-engineered fans are powered by the company's 24-slot motors, and are supplied in models to meet various conditions of altitude or ambient temperatures. Fans and motors are matched for static pressure conditions as required.

The eight-in. fan illustrated operates on 115 v, 60-cps a-c, single phase. Circle 461 inside back cover.



**SILICON MODULATOR**  
replaces choppers

BRADLEY LABORATORIES, INC., New Haven, Conn. A silicon modulator for converting low-level d-c voltages (0 to 500 mv) to a-c signal voltages is announced. Designated the S-1 and developed primarily to replace choppers, the new unit incorporates two silicon diodes with closely matched resistors within a hermetically sealed metal container.

General specifications are: temperature range of -55 C to +85 C; input resistance of 2,700 ohms; output of 0 to 1.6 v a-c linear; balance of 10 mv maximum at room temperature and 15 mv over the temperature range.

Among the advantages which can be listed for the S-1 and other semiconductor modulators are: suppression of side band and

# FANSTEEL

## Silicon

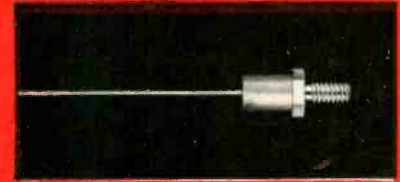

# RECTIFIERS

**For Extreme Miniaturization**

CATALOG NUMBER	PEAK INVERSE VOLTAGE	DC OUTPUT CURRENT 150°C AMPERES
1A11	50	0.25
1A12	100	0.25
1A13	150	0.25
1A14	200	0.25
1A15	250	0.25
1A16	300	0.25

For higher ratings at lower temperatures see graph

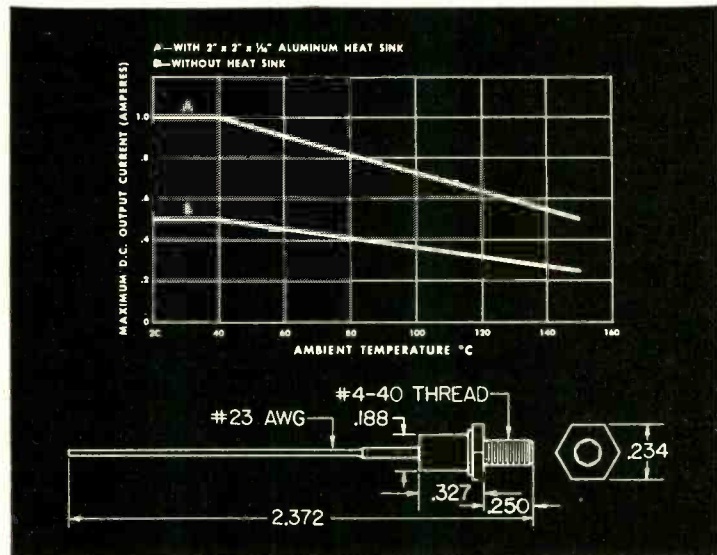

Write for bulletin

**FANSTEEL METALLURGICAL CORPORATION**

North Chicago, Illinois, U. S. A.

**SEE US AT WESCON Booth Nos. 1221-1222**



ES77 A

# WHO IS BORG?

Borg is a highly respected name in its field . . . the manufacture of components for systems. Borg has gained wide recognition as a supplier of electronic components for military and commercial uses.

## BORG PLANTS

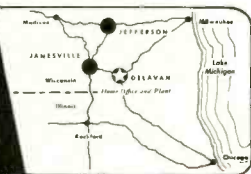

Borg manufacturing plants are centrally located about 90 miles from Chicago. Easily accessible by highway, rail and air.

## WHAT BORG MAKES

*Precision Is Our Business.* For many years Borg has been prominent in the design and manufacture of precision components for systems.

### • AIRCRAFT INSTRUMENTS

Aircraft components, instruments and electronic sub-assemblies.

### • FREQUENCY STANDARDS

Crystal controlled oscillator type frequency standards.

### • POTENTIOMETERS

Quantity production of Borg MICROPOTS (precision potentiometers) to meet your specifications.

### • MICRODIALS

Precision MICRODIALS for single and multi-turn devices. Indexed accuracy of up to one part in 1,000.

### • INSTRUMENT MOTORS

Precision motors, synchronous and induction types. Gear trains.

## BORG CAN HELP YOU

Borg can assist you in the design and construction of prototypes. Complete facilities for pilot runs and quantity production. Write for Bulletin BED-A50 or call us today.



**BORG EQUIPMENT DIVISION**  
THE GEORGE W. BORG CORPORATION  
JANESVILLE, WISCONSIN

Circle 219 Readers Service Card

NEW PRODUCTS

(continued)

carrier frequencies; equally good transmission in either direction; low input and output impedance; no need for filament power or B-plus supply; unusual stability and long life; controlled degree of balance; and assembly of all essential components within a small compact container. Circle 462 inside back cover.

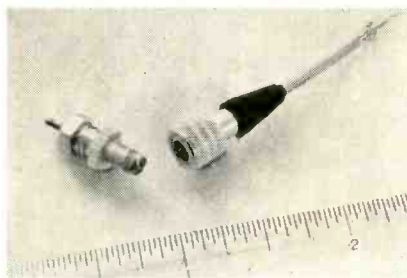

### COAX CONNECTOR subminiature, snap-lock

AUTOMATION-ENGINEERING CORP., 723 Sonora Ave., Glendale 1, Calif., announces a subminiature snap-lock coaxial cable connector and mating receptacle available in 50, 75 and 95 ohm sizes. This design of coaxial cable plug is spring loaded and snaps into position to engage its special receptacle firmly. The plug cannot be removed by pulling on the cable, or by vibration, but only by sliding the knurled sleeve toward the cable end.

These connectors will withstand a temperature range of  $-70^{\circ}\text{F}$  to  $+550^{\circ}\text{F}$  and shock of 100 g on any axis; vibration at 5 g from 10 to 20,000 cycles.

Other design configurations are available—angle feedthrough, hermetic sealed, and the like, as well as engineering facilities for special application. Circle 463 inside back cover.

### VOLTAGE REGULATOR for high frequency use

THE SUPERIOR ELECTRIC Co., 83 Laurel St., Bristol, Conn. Stabiline automatic voltage regulator type IEH5101 for 400 cycle, single phase service gives instantaneous correction of line voltage variations with only 0.25 v bandwidth for line voltage variations and

0.35 v bandwidth for load current and load power factor changes. It is completely electronic with no moving parts.

Ruggedly constructed for long trouble-free life, it is especially well adapted for aircraft (built to meet MIL-E-5400) marine or industrial applications which may be exposed to vibration problems. It is also ideally suited for use in laboratory, inspection and test lines and as a component for other equipment where exacting voltage control is necessary. Input is 95-130 v for nominal output voltage; output: 115 v nominal, adjustable from 110-120 v; load: 1.0 kva; waveform distortion: 3.5 percent maximum at 400 cps; power factor: 0.7 lagging to 1.0 size:  $7\frac{1}{2}$  in. by 5 in. by  $14\frac{1}{2}$  in. including front panel handles. Circle 464 inside back cover.

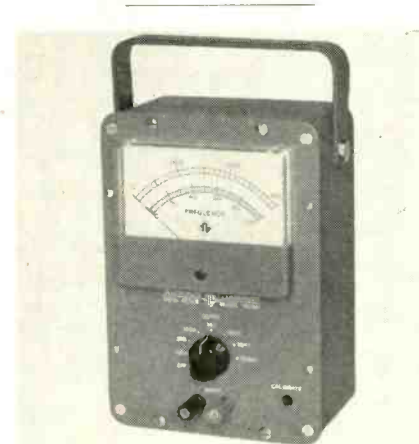

### FREQUENCY METER a transistorized unit

TELETRONICS LABORATORY, INC., 54 Kinkel St., Westbury, L. I., N. Y., has added to its line of modular instruments a transistorized frequency meter. It is designed to measure frequency in the range from 10 cps to 100 kc with an accuracy of 2 percent regardless of wave shape down to a 1 percent duty cycle.

To insure easy, accurate readability seven full scale ranges of 100, 300, 1 kc, 3 kc, 10 kc, 30 kc and 100 kc are provided. Minimum input voltage is 0.1 v rms and maximum 120 v.

The instrument measures  $8\frac{1}{2}$  in. by  $5\frac{1}{2}$  in. by 4 in. and represents a  $\frac{1}{2}$  size module in the TLI modular system. Thus, it will occupy



$\frac{1}{2}$  of the panel area of the modular system rack panel adapter or stack pedestal. Price is \$125. Circle 465 inside back cover.

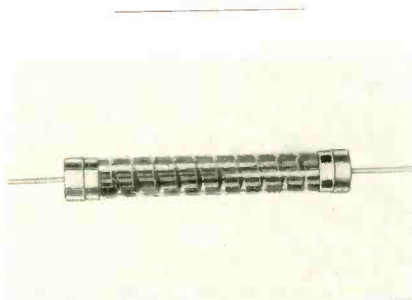

### METAL FILM RESISTORS hermetically sealed

THE DAVEN Co., Livingston, N. J., announces that their new line of Davohm series 850 hermetically sealed metal film resistors are now available and in mass production. This series offers the lowest noise level available (no more measurable noise than on precision wirewounds); low resistance values (as low as 2 ohms in  $\frac{1}{2}$  w size); excellent h-f characteristics (very low reactive impedance component, no plastics to add dielectric losses, no semiconductor effect); temperature range from  $-65$  C to  $150$  C; the same positive temperature coefficient for all resistors from 2 ohms to 4 megohms.

The resistors are completely hermetically sealed in three sizes in ohmic ranges from 2 ohms to 4 megohms in accuracies of  $\pm\frac{1}{2}$ ,  $\pm 1$ ,  $\pm 2$  and  $\pm 5$  percent. They will never short out or burn up since there are no organic compounds which might carbonize or burn. Circle 466 inside back cover.

### LINE REGULATOR magnetic amplifier type

McHENRY CONTROL CORP., P. O. Box 604, Norwalk, Conn. Featuring high transient overload capacity and adjustable output voltage, a new low-priced tubeless regulator is insensitive to frequency changes. A new magnetic circuit reduces weight of the 1 kva unit to 40 lb. Output voltage is regulated from an input of 95 to 130 v, no load to full load. Circle 467 inside back cover.

## "BORG 205 SERIES MICROPOTS SOLVED OUR POTENTIOMETER PROBLEMS"

Borg 205 Series MICROPOTS have proven themselves exceptionally rugged and dependable in many military applications. Borg engineers suggested their 205 series for our commercial units because we needed permanent accuracy in a pot for mobile installations. Borg 205 MICROPOTS stood up perfectly in brutal shock and vibration tests of our units. Investigate the complete line of Borg MICROPOTS . . . there's one for every application!

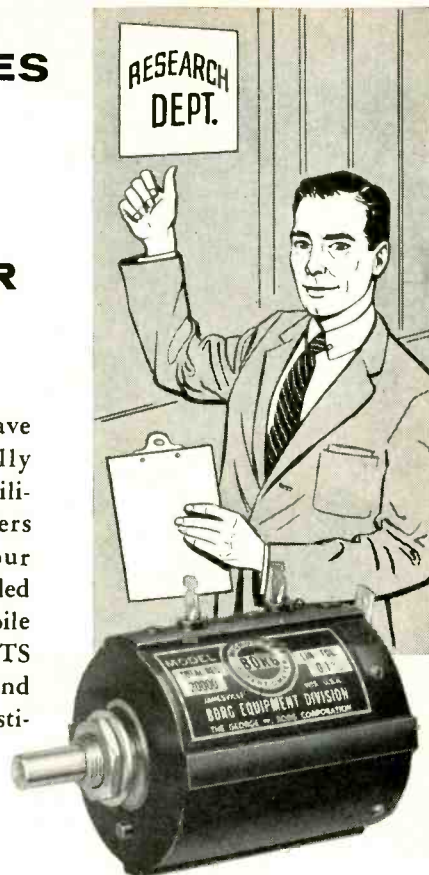

### HERE'S WHY BORG 205 MICROPOTS ARE MORE DEPENDABLE

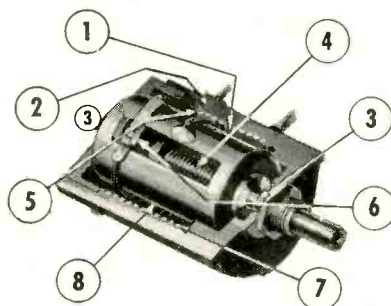

- 1** Resistance wire is precision positioned and moulded integrally with housing.
- 2** Rigid terminals are moulded integrally with housing.
- 3** Two bearings support rotor assembly, assure precise positioning of moving contact.
- 4** Accurate settings, smooth action, low uniform torque are due to precision stainless steel lead screw.
- 5** Terminals soldered to ends of resistance element before moulding. Entire resistance circuit integral part of housing.
- 6** Accurate setting and resetting due to anti-backlash spring in contact guide.
- 7** Finer resolution due to  $43\frac{1}{2}$ " Kohlrausch winding in helical element.
- 8** Each Borg MICROPOT is machine-tested for linearity. Resistance output is directly proportional to shaft rotation.

Write for complete engineering data . . . Catalog BED-A56

**BORG EQUIPMENT DIVISION**

**THE GEORGE W. BORG CORPORATION**

JANESVILLE, WISCONSIN



*Built by Borg*  
MOTORS  
MICROPOTS  
MICRODIALS

# NEW!

**DC to DC and DC to AC  
solid-state power converters  
voltage regulated, frequency  
controlled, for missiles,  
telemetry, gyros, servos**

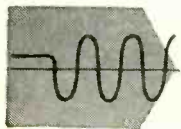
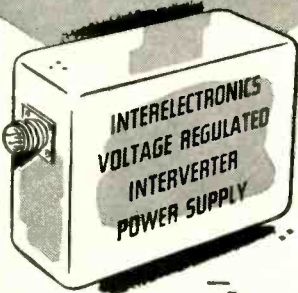

Interelectronics Inverter solid-state thyatron-like elements and magnetic components convert DC to any number of voltage regulated or controlled frequency AC or filtered DC outputs from 1 to 1800 watts. Light weight, compact, 90% or better conversion efficiency.

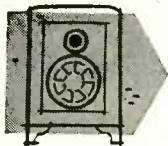

Ultra-reliable in operation, no moving parts, unharmed by shorting output or reversing input polarity. Complies with MIL specs for shock, acceleration, vibration, temperature, RF noise.

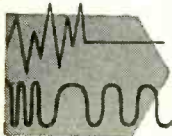

Now in use in major missiles, powering telemetry transmitters, radar beacons, electronic equipment. Single and polyphase AC output units now power airborne and marine missile gyros, synchros, servos, magnetic amplifiers.

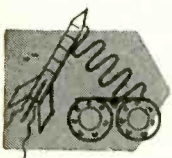

Interelectronics — first and most experienced in the DC input solid-state power supply field, produces its own solid-state gating elements, all magnetic components, has the most complete facilities and know-how—has designed and delivered more working KVA than any other firm!

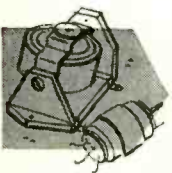

For complete engineering data write Interelectronics today, or call Ludlow 4-6200 in N. Y.

## INTERELECTRONICS CORPORATION

2432 GR. CONCOURSE, N. Y. 58, N. Y.

Circle 221 Readers Service Card

## New Literature

Phase Meters, Delay Lines, Counters. Advance Electronics Lab., Inc., 249-259 Terhune Ave., Passaic, N. J. Features and specifications, as well as illustrations, for a full line of phase meters, delay lines and counters, are given in literature now available. **Circle 501 inside back cover.**

D-C Standard and Null Voltmeter. KIN TEL (Formerly Kay Lab), 5725 Kearny Villa Road, San Diego, Calif. Model 301 d-c voltage standard and null meter is illustrated and described in bulletin 15-3. The unit discussed has stability locked in with chopper amplifiers. A circuit description, applications and specifications are given in the loose-leaf perforated catalog sheet. **Circle 502 inside back cover.**

Servomotor-Rate Generator. Beckman/Helipot Corp., Newport Beach, Calif. Data sheet 869 covers the model 18 MG 490/460, a size 18, 115 v, 400-cycle motor generator. Complete specifications, electrical characteristics, torque-speed curve, 2-view drawing and schematic make this a valuable data sheet for servomechanism designers. **Circle 503 inside back cover.**

Matched Transistor Pairs. General Transistor Corp., 91-27 138th Place, Jamaica 35, N. Y. Specially selected matched pairs of *pnp* and *npn* transistors for use in complementary symmetry circuits are described in a recent data sheet. The pairs discussed (SMP series) are matched in five contiguous beta categories and have a wide variety of applications, especially in transformerless class B push-pull output stages, d-c coupled amplifiers and balanced modulators. **Circle 504 inside back cover.**

Waveguide Pressure Winder. Microwave Associates, Inc., Burlington, Mass. Brochure 57-W describes waveguide pressure windows and their uses. Performance curves, outline dimensions and drawings, and complete

electrical and mechanical data are given in the new brochure for each window type. Helpful installation instructions are also included.

Broad bandwidth, high power, cover-flange-mounted windows for direct mounting between standard flanges in the frequency range from 2.5 kmc to 75 kmc are listed. Solderable windows for sealing reference cavities, filters and so forth, in the frequency range from 2.5 kmc to 16 kmc are also included. **Circle 505 inside back cover.**

Multiconductor Cable. Pacific Automation Products, Inc., 1000 Air Way, Glendale 1, Calif., offers "Design Engineering Specification PAP-C-101" to designers, engineers and purchasing agents.

This comprehensive engineering manual describes materials, construction, design criteria, specification conformance, performance, identification, reproducibility and other important features for determining the correct electronic cable for specific applications. **Circle 506 inside back cover.**

Microwave Components. Microwave Development Laboratories, Inc., 92 Broad St., Babson Park, Wellesley 57, Mass. A new 12-page catalog C457 describes, illustrates and gives simplified ordering information on a full line of hybrid junctions, flanges and adapters which, with appropriate TR tubes, will form microwave duplexers to meet a wide variety of requirements. **Circle 507 inside back cover.**

Ferrite Magnetic Materials. General Ceramics Corp., Keasbey, N. J. An eight-page illustrated bulletin entitled "Ferramics for General Applications up to 200 Megacycles" is available. Fully described is the nature of Ferrites, their advantages and limitations and method of production. Also included is a detailed comparison of Ferramic bodies and



their specific applications to the electrical and electronics industries. **Circle 508 inside back cover.**

**Tape Noise.** Minnesota Mining and Mfg. Co., 900 Bush St., St. Paul 6, Minn. The problem of noise in magnetic tape recordings is discussed in *Sound Talk* bulletin No. 34 now available upon request.

The five-page technical bulletin, illustrated with graphs and line drawings, tells what tape noise is and how it is diagnosed on a tape recorder. Among the considerations covered in the paper are frequency modulation noise, drop-out noise, modulation noise causes, and erasure problems. **Circle 509 inside back cover.**

**Aircraft Type Relay.** Phillips Control Corp., 59 W. Washington St., Joliet, Ill. A single-page bulletin covers the type 57 relay, a rugged, compact, medium-power aircraft type relay, designed to meet the severe environmental conditions imposed by military applications. Illustrations, dimensions and characteristics are included. **Circle 510 inside back cover.**

**Servo System Analyzer.** Servo Corp. of America, 20-20 Jericho Turnpike, New Hyde Park, N. Y. Five models of the Servoscope servo analyzer, including the new model F, are described in a new data sheet.

The model F discussed was developed in response to requests for a model that would accurately measure frequencies as high as 100 cps, yet still afford low end coverage at 0.005 cps. It provides sine, modulated sine and square wave signals as well as the linear sweep and reference carrier on four ranges from 0.005 to 100 cps. For further information, request TDS 1100. **Circle 511 inside back cover.**

**Instrument Translator.** Crescent Engineering & Research Co., 5440 N. Peck Rd., El Monte, Calif., has available a brochure describing the instrument translator, a 10-oz temperature-compensated control system encapsulated in duraluminum case. The unit discussed op-

# EAGLE MULTIFLEX

## (multiple circuit) reset timer

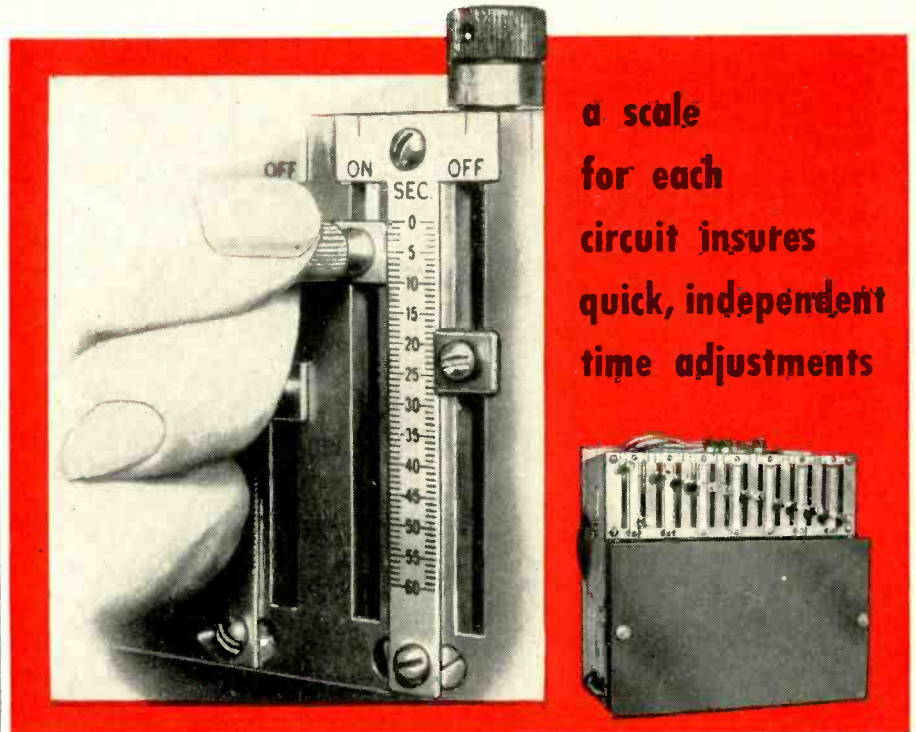

a scale  
for each  
circuit insures  
quick, independent  
time adjustments

For controlling operation phases of electrically energized devices in processing work. The Multiflex Reset Timer closes and opens one to six circuits during a time interval started by push button, limit switch or other means. It's the only multiple circuit timer that provides a calibrated scale for quick, independent adjustment of each circuit. Time changes are made rapidly by moving a simple slide adjustment. Settings are possible to 1% of full scale. Vernier knobs are provided for use where more accurate settings are required. Multiflex Timers are available with time scales from 30 seconds to 5 hours. Send for free bulletin.

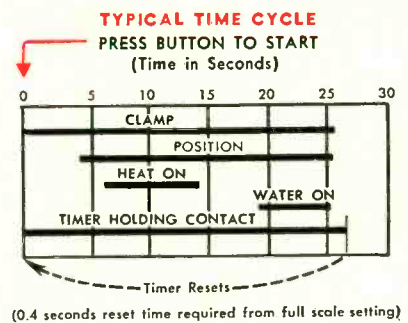

**MAIL COUPON TODAY**

**EAGLE SIGNAL CORPORATION**  
Industrial Timers Division, Dept. E-857  
MOLINE, ILLINOIS

Please send Bulletin 130 containing full data on Multiflex Reset Timer.

NAME AND TITLE \_\_\_\_\_  
COMPANY \_\_\_\_\_  
ADDRESS \_\_\_\_\_  
CITY \_\_\_\_\_ ZONE \_\_\_\_\_ STATE \_\_\_\_\_



# Using Thermistors

Edited by  
**FENWAL ELECTRONICS**

Here's more news on thermistors — the tiny, highly temperature-sensitive, semi-conductors that are being used in more and more applications in all types of industry.

Let's look at just three ways thermistors are now being used . . . Time Delay, Remote Control and Switching.

A thermistor placed with a variable resistor in series with a battery and a relay (Fig. 1) makes an excellent time delay relay. The high resistance of the thermistor limits the current flow when the switch is closed. The delay time may be increased or decreased by increasing or decreasing the series resistance.

By selecting a thermistor with the same constant as the tube filament it will be in series with, you can keep the current constant during the initial warm-up and prevent an initial current surge.

Bead thermistors are available with attached heaters and mounted in a vacuum bulb. (Fig. 2) The thermistors' resistance is reduced when power is applied to the heater. When placed in the input of a vacuum tube amplifier these thermistors make smooth, noiseless remote gain controls, because there are no moving parts or controls in the grid circuit.

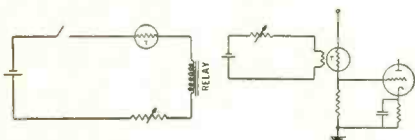

FIG. 1

FIG. 2

When several low voltage light bulbs are connected in series with a suitable thermistor connected in parallel with each unit, (Fig. 3) very little current will pass through the thermistors. Thermistors are not appreciably heated by the small voltage drop across the bulb. If one bulb burns out, the other bulbs remain lighted — the thermistor continues to carry the load of the extinguished bulb. When the bulb is replaced it takes the current from the thermistor. The thermistor then cools off and returns to its idle condition of high resistance and low current.

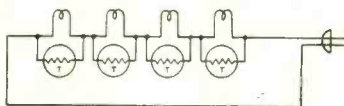

FIG. 3

*Engineers:* these and other thermistor applications are discussed in 12-page catalog EMC-1. Write for your copy to FENWAL ELECTRONICS, INC., 27 Mellen St., Framingham, Massachusetts.



Makers of Precision Thermistors

Circle 223 Readers Service Card

erates from any power source, a-c or d-c, and integrates a-c or d-c sensors with a-c or d-c control mechanisms. **Circle 512 inside back cover.**

**Multiheaders and Plugs.** Hermetic Seal Corp., 29 South 6th St., Newark 7, N. J. Comprehensive information on hermetic seal Vac-Tite compression multiheaders and plugs is offered in a 16-page catalog condensing over 10,000 different types of hermetic seals manufactured by the company. Parts are carefully grouped to provide essential information, part numbers are simplified, and dimensioning standardized for quick, easy reference. Drawings and illustrations are included. Research and engineering facilities are available to solve special hermetic seal design problems. **Circle 513 inside back cover.**

**Microminiature Relay.** Schweber Electronics, 122 Herricks Road, Mineola, L. I., N. Y. An eight-page bulletin features new microminiature sealed relays in high temperature range. It discusses tiny relays with rugged construction, specifically designed for computers and airborne instruments. Specifications and dimensional diagrams are included. **Circle 514 inside back cover.**

**Phototube Catalog.** Continental Electric Co., 6 No. Michigan Ave., Chicago 2, Ill., has published an illustrated eight-page catalog (No. 257) on phototubes and semiconductor lead sulfide photoconductive cells. The new brochure provides full information, including charts and mechanical specifications, on the firm's Cetron-Taylor line. **Circle 515 inside back cover.**

**Delay-Line Flat.** Columbia Technical Corp., 61-02 Thirty-First Ave., Woodside, N. Y. Details and descriptive information on the new Delay-Line Flat are found in bulletin No. 9-56.

The flats discussed have a unique, radically new design—the new elliptical core, which permits the same 5 in. long core to be used in any impedance range from 75 to 7,500 ohms. Maximum

delays range from 0.05  $\mu$ sec at 75 to 125 ohms to 2.0  $\mu$ sec at 2,500 ohms and higher impedances. The standardized physical size facilitates layout problems and provides easy interchangeability of types. **Circle 516 inside back cover.**

**Universal Control System.** Crescent Engineering & Research Co., 5440 N. Peck Rd., El Monte, Calif. The type 67, a 10-lb, single channel control system or carrier amplifier, is covered in a recent four-page folder. The instrument described has modular construction, allowing independent use of regulated power supply, oscillator and amplifier, and provides choice of six excitation frequencies for operation of most types of transducers. **Circle 517 inside back cover.**

**Magnetics Data.** Avion Division, ACF Industries Inc., 11 Park Place, Paramus, N. J. A single-sheet bulletin covers PQ magnetics. Features listed are: (1) magnetics to meet your requirements; (2) minimum size and weight; (3) rugged premium construction; (4) quality production; and (5) reliable performance. The bulletin announces a new and complete magnetic component service which was born of necessity to meet Avion's own requirements for both standard and specially designed units. Types of components, characteristics and advantages are given. **Circle 518 inside back cover.**

**Semiconductor Products.** General Electric Co., Syracuse, N. Y., has available a monthly Newsletter on its semiconductor products. It will be mailed regularly to those who request it. **Circle 519 inside back cover.**

**Automatic Wave Analysis.** Minneapolis-Honeywell Reg. Co., Davis Laboratories Div., 10721 Hanna St., Beltsville, Md. How automatic wave analyzers can speed reduction of analog data and increase statistical reliability provides the subject matter for bulletin 9001. The bulletin points out the advantages of analog re-



duction of analog data in eliminating such tedious and time consuming steps as manual fairing, measuring or sampling, or analog-digital conversions.

Bulletin 9001 concludes with a rundown of the general specifications of two of the company's analyzers that perform all reductions from the original recorded data to a permanent printed plot of amplitude vs frequency or power vs frequency automatically. **Circle 520 inside back cover.**

**Dual-Purpose Antenna.** Aircraft Radio Corp., Boonton, N. J. Standing-wave ratios and radiation pattern diagrams and descriptions of the type A-13B vhf navigational antenna are contained in a new brochure. Type A-13B discussed incorporates two broadbanded antennas, one for use with VOR and runway localizer receivers and one for use with glide-path receivers. It is designed for use on all types of aircraft. **Circle 521 inside back cover.**

**Teflon Wire and Cable.** American Super-Temperature Wires, Inc., West Canal St., Winooski, Vt., has published a 30-page catalog on Teflon insulated wires and cables. Complete specifications and prices are presented on Teflon and silicone insulated magnet wires, lead wires, lacing cords, sleeving, tubing and shielded and jacketed miniature cables. Helpful information on applications is also included. **Circle 522 inside back cover.**

**Long-Life Capacitors.** Industrial Condenser Corp., 3243-65 N. California Ave., Chicago 18, Ill. A new 12-page catalog 1165 presents data not previously available on electrolytic capacitors and describes the new Royaltic long-life capacitor which eliminates such problems as short operating life, excessive leakage currents and rapid shelf aging of conventional electrolytic units. **Circle 523 inside back cover.**

**Power Rectifiers.** Sarkes Tarzian, Inc., Rectifier Division, 415 N. College Ave., Bloomington, Ind., has available fly sheets numbers 16,

look what **\$24<sup>50</sup>** buys  
in test equipment!

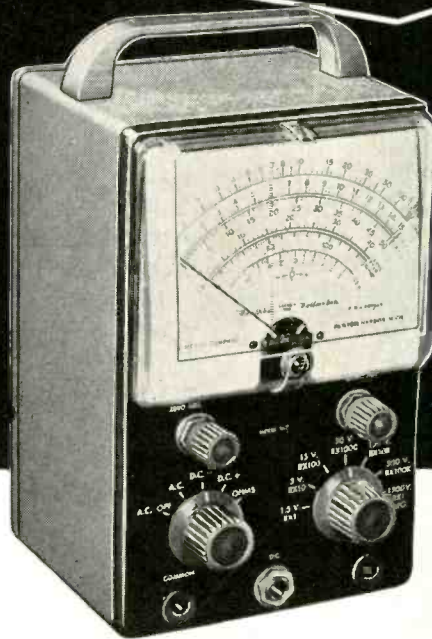

**HEATHKITS  
GIVE YOU  
TWICE AS MUCH  
equipment for  
every dollar  
invested**

The famous model V-7A Vacuum-Tube-Voltmeter is a perfect example of the high-quality instruments available from Heath at  $\frac{1}{2}$  the price you would expect to pay! Complete, only **\$24<sup>50</sup>**

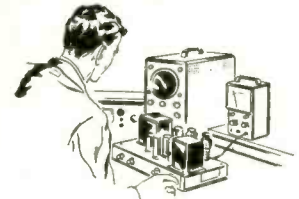

Get the most out of your test equipment budget by utilizing HEATHKIT instruments in your laboratory or on your production line. Get high quality equipment, without paying the usual premium price, by dealing directly with the manufacturer, and by letting engineers or technicians assemble Heathkits between rush periods. Comprehensive instructions insure minimum construction time. You'll get more equipment for the same investment, and be able to fill your needs by choosing from the more than 100 different electronic kits by Heath. These are the most popular "do-it-yourself" kits in the world, so why not investigate their possibilities in your particular area of activity! Write for the free Heathkit catalog now!



Contains detailed descriptions of Heathkit models available, including VTVM's, scopes, generators, testers, bridges, power supplies, etc.



Also describes Heathkit ham gear and hi-fi equipment in kit form. 100 interesting and profitable "do-it-yourself" projects!

**FREE catalog**

Mail coupon below for your copy—Now!

**HEATH COMPANY**  
A SUBSIDIARY OF DAYSTROM, INC.,  
BENTON HARBOR 14, MICHIGAN

Name \_\_\_\_\_

Address \_\_\_\_\_

City & Zone \_\_\_\_\_

State \_\_\_\_\_

# Precision



## Deflection **YOKES** and Systems

We now supply yokes to the largest laboratories and defence projects in the U. S. A. Available to customers specs. in Nickel Iron, Ferrite, Class A or H insulation. Moulded-in slip rings can be supplied.

Linearity - standard  $\pm 1\%$ , custom build to  $\pm .1\%$ .

Orthogonality  $\pm \frac{1}{4}^\circ$ .

Half-axis collinearity  $\pm \frac{1}{2}^\circ$ .

Mutual interaxis coupling .0025 or as specified by customer.

Differential capacity unbalance - 3.5 uuf max.

High Altitude Performance is limited only by flashover point of the terminals, which can be specified by customer.

Temperature Range -

Standard deflection yokes will operate as specified from  $-10^\circ\text{C}$  to  $+60^\circ\text{C}$ .

Class H insulated deflection yokes will operate from  $-50^\circ\text{C}$  to  $+160^\circ\text{C}$ .

Humidity: The yoke is unaffected by humidity.

Meet JAN and MIL Specs.

For further information write:

# COSSOR

(CANADA) LIMITED  
301 Windsor Street  
Halifax, Nova Scotia  
Phone 4-6487

Circle 225 Readers Service Card

NEW LITERATURE

(continued)

17, 18 and 19 dealing with different types of silicon rectifiers. Specifications, characteristics and dimensions are shown. Circle 524 inside back cover.

**Electromechanical Breadboard Parts.** Beckman/Helipot Corp., Newport Beach, Calif., has published a catalog offering complete descriptions of all parts necessary for the easy assembly of complicated gear trains and servomechanisms. The 24-page book also includes typical schematics which are representative of basic synchro transmitter and receiver systems, potentiometer transmitter and receiver systems, and a mechanical resolver system.

Each component is described in detail in the approximate order in which it would be used while setting up a typical system. All necessary information is in one place, including pictures, specifications, outline drawings and complete ordering instructions. Circle 525 inside back cover.

**Electronic Components.** Onandaga Pottery Co., Syracuse 1, N. Y. A 32-page booklet includes a discussion and listing of general characteristics of printed electronic circuits. Radio receiver and television receiver components are covered and circuits are illustrated. Circle 526 inside back cover.

**Ceramic Capacitors.** Automation Components, Inc., 875 Hickory St., Peckville, Pa. A four-page catalog sheet covers a line of by-pass disk capacitors, temperature compensating disk capacitors, and high voltage tubular and disk capacitors. Specifications are included. Circle 527 inside back cover.

**Frequency Period & Time Interval Meter.** Electro-Pulse, Inc., 11861 Teale St., Culver City, Calif. A single-page bulletin describes model 7550B frequency, period and time interval meter which measures from 0.1 to 100 kc and 100  $\mu\text{sec}$  to 1.2 days with 200-mv input sensitivity. The instrument discussed is designed for flow measurement, filter characteristic determination, accurate frequency

determination, oscillator calibration, rpm monitoring and timing of physical events. Circle 528 inside back cover.

**Pulse Programming Equipment.** Navigation Computer Corp., 1621 Snyder Ave., Philadelphia 45, Pa., has released a new brochure describing the technical features of its transistorized pulse programming equipment. It offers descriptions, specifications and illustrations of the individual units as input and output waveforms. The brochure has an index tab as an aid to filing and allows for the later insertion of additional specifications sheets. Circle 529 inside back cover.

**Laboratory Power Supplies.** Burroughs Corp., Electronic Instruments Division, 1209 Vine St., Philadelphia 7, Pa., has published a new brochure illustrating and describing three power supplies in the laboratory instrument line.

The units discussed in the four-page brochure—types 9001, 9102 and 9202—provide up to eight standard voltage outputs both positive and negative from +400 v d-c to -400 v d-c and cover a range of current capacities from 2 ma to 6 amperes. Regulation on each of the supplies discussed is maintained at better than  $\pm 5$  percent for all output voltages. Ripple voltage is kept to a minimum of less than 0.5 percent rms. Circle 530 inside back cover.

**Ultrasonic Gaging.** Branson Instruments, Inc., 37 Brown House Road, Stamford, Conn., has announced a new eight-page technical bulletin on the Vidigage, an ultrasonic resonance instrument used for fast, nondestructive testing. Bulletin V-200 gives complete data on the time-saving advantages of using the instrument to measure thickness of metal, glass and plastic from one side and to find corrosion, laminar discontinuities or other flaws. Circle 531 inside back cover.

**Component Bulletin.** Richards Electrocraft, Inc., 3739 N. Kedzie Ave., Chicago, Ill. A new eight-



page bulletin gives complete information on the company's products including plugs, jacks, connectors, adapters and push-button switches in both standard and miniature sizes. Parts are completely illustrated; drawings show construction details and tables list sizes and types available. **Circle 532 inside back cover.**

**Quick Reference Catalog.** Eitel-McCullough, Inc., San Bruno, Calif., has published a new 16-page 3-color quick reference catalog.

Summarized electrical and physical data are given in handy tabulated form for each of the company's line of triodes, tetrodes, pentodes, klystrons, high vacuum and mercury vapor rectifiers, vacuum capacitors, vacuum switches, ionization gage, contact finger stock, heat dissipating connectors, air system sockets and chimneys. **Circle 533 inside back cover.**

**Microwave Components.** Microwave Associates, Inc., 22 Cummington St., Boston 15, Mass. An attractively illustrated four-page short-form brochure describes microwave waveguide components and test equipment in the 2.63 to 75-kmc frequency range.

The components are listed both in numerical order by model number, including frequency ranges and prices, and separately by function and waveguide size. More than 200 instruments are listed, including coaxial and cartridge-type bolometers (barreters and thermistors), branch guide and sidewall directional couplers, antenna rear feeds, crystal mounts and balanced mixers, precision variable attenuators, tunable thermistor mounts, fixed attenuator pads, matched and unmatched hybrid tees, bends, twists and transitions. **Circle 534 inside back cover.**

**Relay Catalog.** Magnecraft Electric Co., 3350B W. Grand Ave., Chicago 51, Ill. A handy engineering catalog describes printed circuit relays, miniature and subminiature, 6pdt and power relays, snap action relays, 400-cps relays, and



## DESIGNS RELAYS

### TAILORED FOR AIRBORNE SYSTEMS

...relays featuring the unique capability that continuously solves environmental problems for customers such as: Boeing • Douglas Aircraft • Grumman Aircraft • Hughes Aircraft • Lockheed Aircraft • Minneapolis-Honeywell • North American Aviation.

Now . . . Relays TAILORED for Flight Control • Automatic Approach • Engine Control • Missile Guidance • Missile Stabilization • Bomb-Navigation • Inertial Navigation • Fire Control • Automatic Flight.

Why not test Leach's ability to solve some of your toughest environmental problems? Please write Sales Manager, Relay Division or contact your nearby Leach representative. *Send for your copy of the Leach Balanced-Armature Catalog.*



# LEACH

CORPORATION

## LEACH RELAY DIVISION

5915 Avalon Blvd., Los Angeles 3, California

District Offices and Representatives in Principal Cities of U. S. and Canada



# SILVER PAINT AND SILVER PASTE

Take the "bugs" out of the application of conductive silver coatings. Use Drakenfeld silver paint and silver paste tailored to meet your needs. We formulate special compositions for glass and ceramic bodies and other materials. Let us know your specific requirements. Samples will be supplied to fit them. Your inquiry will receive prompt attention.

**B. F. DRAKENFELD & CO., INC.**

Box 519, Washington, Pennsylvania

*Drakenfeld*

**YOUR PARTNER IN SOLVING CONDUCTIVE COATING PROBLEMS**

Circle 227 Readers Service Card

## Century MODEL 409

### RECORDING OSCILLOGRAPH

FOR VIBRATION, TEMPERATURE, STRESS, STRAIN RECORDING

The Century Model 409 Oscillograph was designed for operation under the most adverse conditions and more especially, where space and weight considerations are limited.

This Oscillograph is one of the smallest and most compact units available on the present market, yet it incorporates many features found in larger oscillographs, such as trace identification, trace viewing, continuously variable paper speeds and others. The Model 409 Oscillograph has been tested and proven to record faithfully during accelerations in excess of 20 g's.

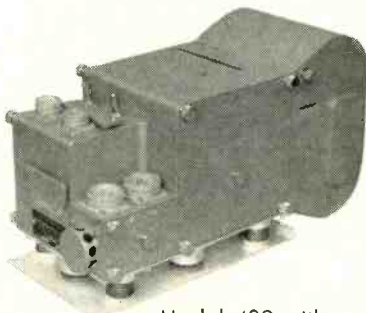

Model 409 with  
100 ft. Capacity Magazine

This makes it especially desirable for uses such as missile launching, parachute seat ejection, fighter aircraft and torpedo studies.

Write for Bulletin CGC-303 and CGC-301

**Century Electronics & Instruments, Inc.**

1333 No. Utica, Tulsa, Oklahoma

Circle 228 Readers Service Card

NEW LITERATURE

(continued)

rectified relays for quiet operation and increased reliability on a-c. It also includes a wide selection of relays with hermetically sealed and dust-tight enclosures; with removable dust covers; and with dust-tight observation window enclosures. Circle 535 inside back cover.

**Recent Electron Tube Developments.** Eitel-McCullough, Inc., San Bruno, Calif. "What's New With The Electron . . . 1957" is a 20-page, 2-color brochure on recently developed Eimac products.

Basic electrical data are supplied on many new tube types, with emphasis on new developments in ceramic tube design. Information is included on klystrons, power tetrodes, triodes, ceramic receiving tubes, beam switch tubes and beam rectifiers, high vacuum rectifiers, air system sockets and klystron amplifier circuit components. Circle 536 inside back cover

**Current Governor.** North Hills Electric Co., Inc., 402 Sagamore Ave., Mineola, N. Y. A single-page bulletin illustrates and describes the model CG-1 current governor, a two terminal current stabilizer modulator and programmable electronic load. Applications and specifications are listed. Circle 537 inside back cover.

**Corona Type Voltage Regulators.** The Victoreen Instrument Co., 5806 Hough Ave., Cleveland 3, Ohio, announces availability of an engineering paper on corona type voltage regulators.

The eight-page paper describes how corona regulators can solve voltage regulation problems without the use of multitube circuits. It is illustrated with performance curves, graphic analysis of corona regulator operation and gives typical schematic diagrams for use in cascade regulators, circuits for increasing current rating, cathode follower regulator circuit and other applications. Circle 538 inside back cover.

**Seismic Data Processing Equipment.** Texas Instruments Inc., 6,000 Lemmon Ave., Dallas 9,



Texas. Descriptions of "seisMAC", the only all electronic seismic data processing computer on the market, and its related equipment for central office processing, are contained in a new eight-page brochure.

In addition to detailing the economic and technical advantages of the TI-Central office processing system, the bulletin contains descriptions of such other components of the system as "magne DISC", disk-type magnetic recorder; the 7000B all-purpose amplifier, and the T-Z (time-depth) camera. Write for Seismation bulletin No. S-318. **Circle 539 inside back cover.**

**Electrochemical Assembly Kits.** Servo Corp. of America, 20-20 Jericho Turnpike, New Hyde Park, N. Y. A new instruction book containing tables of common gear ratios and moments of inertia has been prepared for Servo board electromechanical assembly kits. The eight-page booklet spells out instructions for installing components in hangers, installing hangers and gears, gear alignment and gear selection. **Circle 540 inside back cover.**

**Audio Frequency Equalizers.** Cinema Engineering Division Aerovox Corp., Burbank, Calif. A 16-page catalog, "Audio Frequency Equalizers," contains product illustrations and two dozen charts showing response characteristics, dialog and variable equalizer diagrams.

The units described provide standard networks which, in simplified and flexible arrangements, may be used to build up almost any type of audio frequency response characteristic.

Principle use of the items discussed is in the fields of: industrial and scientific research, telecommunications, tv and broadcasting, sound recording and motion pictures.

A deviation from the usual catalog style is the inclusion of eight case studies—problems and solutions from experience in actual usage. **Circle 541 inside back cover.**

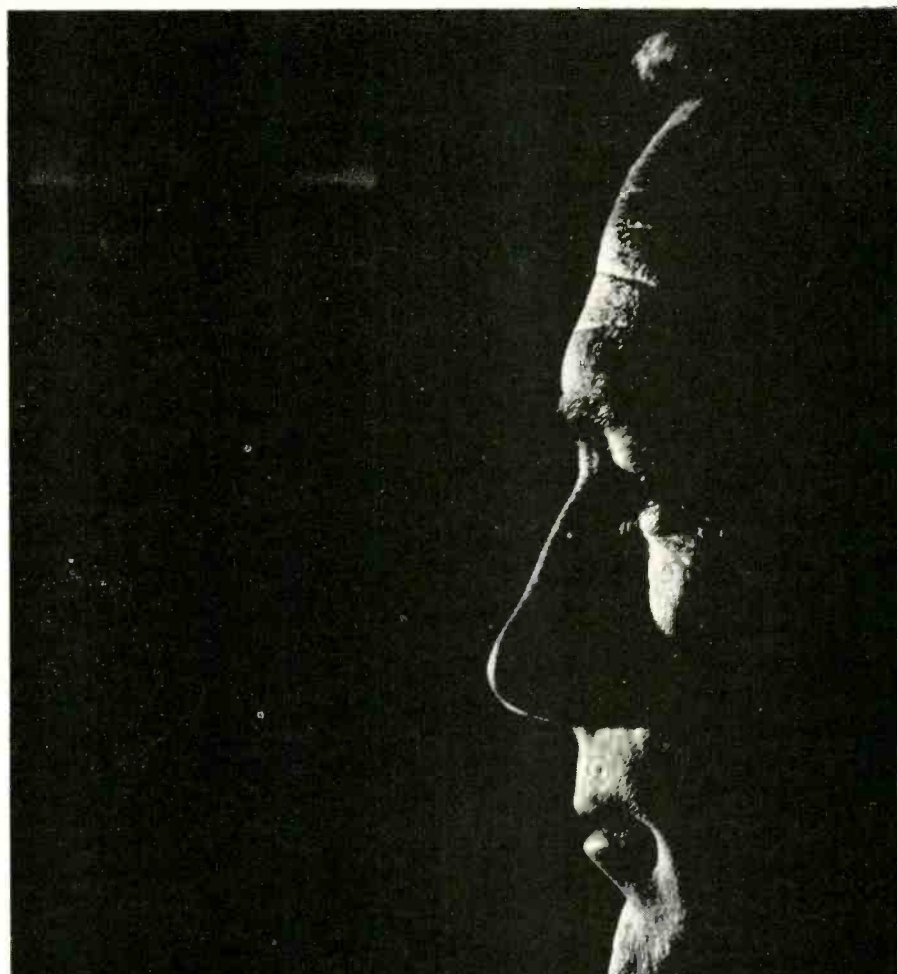

profile of a  
**very special guy**  
... the Lenkurt engineer

What makes him special?  
First there's the man himself. Lenkurt attracts the highest caliber.  
Then there's the environment in which he lives. At San Carlos, on the sunny San Francisco peninsula, the Lenkurt Engineer enjoys California living at its finest.  
Last, and most important, is his **working** environment. At Lenkurt, in an atmosphere of congeniality and well-being, the engineer finds inspiration for his best creative efforts. His contribution is quickly recognized, promptly rewarded.

Immediate opportunities exist at Lenkurt for some very special guys interested in:

- Components Development Engineering
- Product Planning Engineering
- Applications Engineering
- Circuit Design Engineering

*Lenkurt*  
ELECTRIC  
San Carlos 3, California

Please send your resumé to Dan Foster, Engineering Placement Manager

# Plants and People

Edited by WILLIAM P. O'BRIEN

Electronics manufacturers expand plants and facilities by acquisition, leases or new construction. Top engineers and executives in the industry are promoted and move to new responsibilities. MIT Opens \$4,000,000 Laboratory

## Burroughs' Electro Data Completes Computer Facility

COMPLETION of a sixfold enlargement of its Pasadena plant, now totaling 250,000 sq ft, was recently announced by the Electro Data Division of Burroughs Corp. The \$4-million plant is the West's largest engineering and production facility for electronic computers.

A chief feature of the building is the integrated electronic data processing center, where a quarter-million dollar Datatron system is installed for contract computation.

In addition to manufacturing Datatron electronic data processing systems, Electro Data markets the E101 desk-size computer and the series G high-speed printing, tabulating and punch-card equipment.



Electro Data's new computer facility in Pasadena, Calif.

## RCA to Establish Major Lab in Boston Area

CONSTRUCTION of a 132,000-sq ft, single-story major electronics laboratory for military airborne equipment and systems is now under way in the greater Boston area. It is scheduled for completion by June, 1958, according to present plans.

The new lab will be erected on a 35-acre tract near the intersection of Routes 128 and 3, between Burlington and Bedford, Mass. It will provide engineering space and developmental facilities for approximately 300 electronic engineers and scientists and an equal number of supporting personnel.

The Boston Laboratory will be equipped with the latest in electronic test equipment and computing devices, and will feature a modern model shop and one of the

nation's most extensive installations of flight simulation facilities. The simulation facilities provide computers, a replica of a jet aircraft complete with operating controls, and other devices to enable RCA engineers to forecast with electronic precision the nature of airborne systems needed to meet specific aeronautical goals. Simulation makes possible performance evaluation of such systems while under development, and with important reductions in time-and-cost consuming flight tests.

## Bendix Expanding for Missile Work

PACIFIC DIVISION of Bendix Aviation Corp. is constructing a 12,000 sq ft addition to its manufacturing facilities in North Hollywood,

Calif., to provide necessary space for the division's missile programs.

The new building area is required primarily for the assembly and testing of hydraulic components being produced under contract by the division for the Atlas, Titan, Nike, Terrier, Talos, Sparrow and other missiles slated for future production.

## Sperry Rand Builds In Florida

CONSTRUCTION of a \$2,000,000 electronics facility for development of advanced radar instrumentation by Sperry Rand Corp., in Clearwater, Fla., began in June. The newly organized electronics division will consist of an initial 75,000 sq-ft air-conditioned laboratory structure. First operations of the new division will employ approximately





**Good-ALL**  
capacitors

# The 600 UE

## A **MYLAR\*** dielectric capacitor **MOLDED IN EPOXY**

The superior moisture resistance of EPOXY gives far better humidity protection than commonly used molding materials. High dielectric strength is also an attractive property of this tough, dense plastic.

Exclusive Good-All molding technique eliminates all possibility of deforming or otherwise damaging windings during the molding process. Uniform wall thickness is carefully maintained.

**600-UE**

Leads are securely bonded in the EPOXY molding compound. This extremely tight bond prevents moisture from entering the capacitor at this point.



The dark maroon capacitor body is exceptionally durable as well as attractive. Since overall dimensions are held within close tolerances, this capacitor type is ideal for automatic machine insertion.



**600-UPE**

The same quality features illustrated in the cut-away drawing are available in *Pin Types* for use in upright mounting.

### TYPICAL APPLICATIONS

Electronic Organs . . . Test Equipment . . . Communication's Systems . . . TV Receivers

The outstanding combination of a space-saving Mylar winding sealed in moisture resistant EPOXY provides you with premium performance in a rugged compact design. This new capacitor incorporates these valuable properties of Mylar dielectric . . . **HIGH IR, STABILITY WITH LIFE and LOW POWER FACTOR.** Good-All Types 600-UE and 600-UPE (for upright mounting) are priced to encourage widespread use in both consumer products and industrial equipment.

\*DU PONT'S TRADEMARK FOR POLYESTER FILM

### SPECIFICATIONS

- Insulation Resistance** . . . Greater than 75,000 Megohm-Mfd. at 25°C (See curve below for higher temperatures)
- Power Factor** . . . . . Less than 0.6% from +25°C to +85°C
- Temperature Range** . . . . . May be operated at rated voltage from -65°C to +85°C and to +125°C with derating
- Humidity Resistance** . . . . . Far surpasses requirements of RETMA Spec. REC-118-A
- Voltage Range** . . . . . 100, 200, 400 and 600 Volts D.C.

INSULATION RESISTANCE vs. TEMPERATURE  
Temp.—Degrees Centigrade

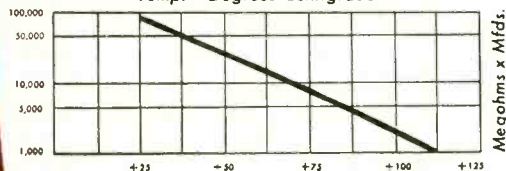

DIMENSIONS OF TYPE 600-UE, 100 VOLTS D.C.

CAP.	SIZE	CAP.	SIZE
.015	.312 x 1 <sup>1</sup> / <sub>16</sub>	.15	.500 x 1 <sup>1</sup> / <sub>16</sub>
.047	.375 x 1 <sup>1</sup> / <sub>16</sub>	.22	.500 x 1 <sup>1</sup> / <sub>16</sub>
.1	.438 x 1 <sup>1</sup> / <sub>16</sub>	.47	.562 x 1 <sup>1</sup> / <sub>16</sub>

Our engineers are ready to work with you on special applications. Write or wire for specifications and quotations.



**GOOD-ALL ELECTRIC MFG. CO.** • OGALLALA, NEBRASKA

A leading manufacturer of Tubular and Ceramic Disc Capacitors

150 scientific and technical personnel.

The company plans to utilize the new facility to expand its development and testing of new microwave

and electronic instruments designed to control and monitor various functions in aircraft and missile systems, industrial processes, and other new types of electronic

systems. Over \$1,000,000 in scientific instruments, special machine equipment, and test facilities will be installed before operations begin late this year.

## Largest Magnetic Tape Plant Opened In Minnesota



Minnesota Mining and Mfg.'s new magnetic tape plant

A PLANT estimated to be capable of meeting the recording demands of the entire world for the next 10

years, was recently put into 24 hour-a-day production by Minnesota Mining & Mfg. Co., St. Paul,

Minn. It is a factory built and maintained to achieve near-sterile conditions required to produce essentially perfect magnetic tapes necessary for such critical applications as video tape recording, electronic computers and instrumentation recording.

Dr. W. W. Wetzel, general manager of the firm's Magnetic Products division, said that the 78,000 sq-ft unit, located at Hutchinson, Minn., incorporates the ultimate in tape-making technology based on a half century's experience in applying precision coatings, and more than a decade of pioneering in the production of highly specialized tapes for magnetic recording.

## Consolidated Avionics Announces Two Appointments

HARRY GLIXON, president of Consolidated Avionics Corp., recently announced that Edward Foodim has been appointed assistant to the president, and Ira L. Kasindorf has succeeded E. Foodim as chief engineer.

Foodim is a specialist in design and production of large scale data

reduction instrumentation systems.

Kasindorf comes to Con Avionics from Servomechanisms, Inc., where he was chief engineer of the Components Division at Westbury, L. I. Before joining Servomechanisms, Kasindorf was a project engineer with Airborne Instruments Laboratories, Inc., and prior to that was

on the National Advisory Council Committee for Aeronautics, Moffet Field, Calif.

Consolidated Avionics is a subsidiary of Consolidated Diesel Electric Corp., Stamford, Conn., manufacturer of aircraft ground support, power and test equipment for industry.



Edward Foodim



Ira L. Kasindorf

### Ivans Named V-P At Kin Tel

APPOINTMENT of William S. Ivans, Jr., as vice president in charge of engineering for Kin Tel, a division of Cohu Electronics, Inc., has been announced.

Ivans was formerly chief electronics engineer of Convair, and is outstanding in the field of electronic instrumentation.

He joined Convair as project engineer in 1946. Initially, he directed the development of a complex radar homing and flight control system for Navy missile proj-



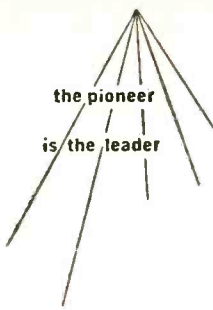

**PANORAMIC**  
introduces...

Quick accurate visual analysis of measurement problems made possible by Panoramic instruments has speeded research and development projects... cleared production test bottlenecks. Their broad range panoramic displays eliminate tedious, complicated point by point measurements... present an easily read, graphic "picture", simple to analyze. Panoramic's wide variety of spectrum analyzers, unique response curve tracing systems and telemetering test instruments have made them pioneers and leaders in the field.

Time-saving and precedent-setting, these new instruments open up completely new areas of measurement through visual analysis.

# new ways in new instruments that rapidly solve measurement and analysis problems

## Model TDC-5, Panoramic Telemetering Simultaneous 5-Point Calibrator and Dynamic Checker

For the FM/FM telemetry field, the new TDC-5 offers two important new facilities: A simultaneous five-point calibrator for discriminator linearity measurements in all of the 18 RDB subcarrier channels and the 5 optional 30% channels. A dynamic checker which converts any phase distortion in the discriminator package into harmonic distortion for sensitive determination and analysis on the screen of a Panoramic Spectrum Analyzer.

Packaged in modular form with individual chassis and interchangeable crystal assemblies for each channel, a common simultaneous output terminal and function control is provided in a master unit.

In its first function, the TDC-5 furnishes five deviation frequencies for each channel—for example, +7.5%, +3.75%, 0%, -3.75%.

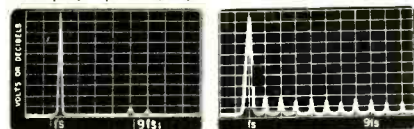

I. Linear discriminator spectrum II. Harmonic from 2nd thru 8th due to Non-Linear discriminator. Spectrum analysis of discriminator staircase output. Fundamental Frequency (f) = Staircase Repetition phase distortion

Other deviation frequencies can be set if desired. Each frequency is crystal controlled and precise to within  $\pm 0.02\%$ . Operation may be automatic, semi-automatic or manual. On automatic, frequencies are stepped sequentially for all channels included in system.

As a dynamic checker, a stepped FM wave is generated for each subcarrier discriminator. As the stepping rate is increased beyond the permissible information rate, significant distortion of the FM envelope is detected as harmonic distortion of the stepping frequency on the screen of the Panoramic Spectrum Analyzer. By simply adjusting the cycling rate of the TDC-5 (continuously variable from 2 to 2,000 cps), maximum capacities of each channel may be established easily by visual analysis. New and valuable information for all FM/FM telemetering systems obtained quickly and easily on Panoramic's new TDC-5.



## Model PA-1, Panoramic Sonic Phase and Amplitude Response Analyzer

A unique dual purpose instrument, the PA-1 permits rapid tracing of both the amplitude and phase shift characteristics of audio band networks. Each characteristic is displayed as a single line curve... on the identical frequency scale... on the 5" CRT screen of Panoramic's companion Model LP-1a Sonic Analyzer. Function selection is accomplished through a single front panel switch.

Phase angle is read on the vertical linear scale calibrated up to  $180^\circ$  at full scale. A fewer number of degrees may be expanded to full scale for greater reading accuracy of small phase shifts with higher sensitivity settings. Lag and lead sense are determined by an internal circuit.

Amplitude scales are linear and two decade log. The PA-1 may be used without performance degradation even at attenuations greatly exceeding 100 db... enhancing even more the versatility of Panoramic's Selective Frequency Response System.



Frequency scales are 40 cps to 20 kc logarithmically or any 200, 1000, or 5000 cps linear segment within a 20 cps to 22.5 kc range. Scanning rates are 1 cps internally

... variable from 0.05 to 60 when used in conjunction with Panoramic's Model TW-1 Triangular Wave Generator.

## Model PDA-1, Panoramic Spectral Power Density Analyzer

Specifically designed to provide an accurate analysis of the relative spectral energy distributions of random waveforms, typical of complex vibrations and noise data, the PDA-1 offers an excellent quantitative solution to the problem of adequately sampling a non-discrete function. Used with the appropriate automatically scanning Panoramic Spectrum Analyzer, it will cover any frequency range from subsonic through microwave.

Operation is simple and automatic. The PDA-1 sums up all signal contributions at each small frequency band (as determined by the resolution capabilities of the companion analyzer) and reads out at a figure equal to the total energy content. The integration process is repeated at the adjacent band, and so on, throughout the spectrum of interest. When the input data is presented from a looped tape recording, the sampling interval is synchronized with the loop period thus intercepting all segments. Total scan time is adjustable up to 60 minutes, integration intervals 1-30 seconds.

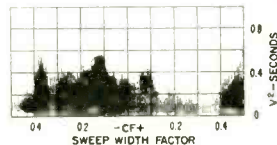

Spectral density analysis of random vibration data. PDA-1 read-out through LP-1a Sonic Analyzer on companion recorder, Model RC-3.

## Model DD-1, Panoramic Ultrasonic Delay Distortion Indicator

This instrument makes possible automatically the detection of minute time delay variations of ultrasonic networks as a function of frequency. In many types of networks (such as, bandpass filters and video amplifiers) the relative uniformity of delay over a band of interest is much more important than total transmission time between input and output terminals. The DD-1 is the answer... it gives an extremely sensitive measure of incremental delay distortion defined by the variation in slope of the phase angle vs.

frequency curve... traces out a horizontal plot for networks with uniform delay in a band. Frequency ranges from 8 to 300 kc.



## Model SF-1, Panoramic Synchronous Frequency Analyzer

A receiver which monitors the vibrations of mechanical devices at the frequency equal to the instantaneous rotating or reciprocating speed, the SF-1 automatically tracks machine speed as it is varied under test. Thus, a complete characteristic of the relative vibration levels vs. frequency is obtained throughout the entire speed range. All other vibration frequency components, harmonics, noise, etc., are severely attenuated. If desired the SF-1 may be locked onto one of the several harmonics of the rotating speed.

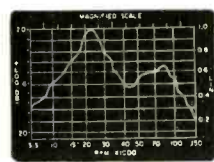

Frequency ranges are a broad band scale on the calibrated H axis... any 10% segment may be magnified to full scale width for detailed examination. Amplitude scales are linear and two decade log. Readout is on a 5" CRT or an external X-Y recorder.

This form of fundamental component study with the SF-1 is an invaluable aid in dynamic balancing and in pinpointing resonant conditions.

▲ Amplitudes of fundamental vibrations at the frequencies of rotation automatically traced by Model SF-1.

## PANORAMIC RADIO PRODUCTS, Inc.

New Address: 522 South Fulton Avenue, Mount Vernon, N. Y.  
Phone: MOUNT VERNON 4-3970 • Cables: Panoramic, Mount Vernon, N. Y. State

This is our new home. Modern, up-to-the-minute, it will double engineering and production facilities... provide greater efficiency.



see us at the  
Wescon Show  
Booth 814

If you can't be there, write, wire or phone NOW for complete information on these new instruments.

A Panoramic Applications Engineer is always available to discuss specific problems.



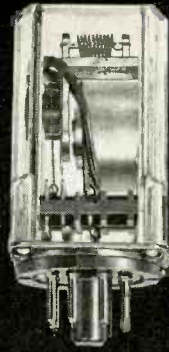
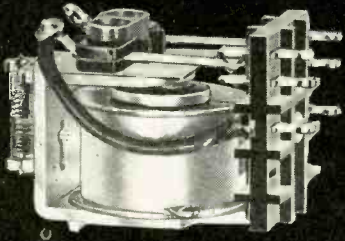

**ELGIN**  
announces the

**NEW ADVANCE**

*Low Cost*

# Midget Relays

... open or plastic enclosed

Elgin's new GH series combines the high efficiency required of general purpose relays with low cost. Their midget size suits them for installations where space is a problem (see specifications below). Open relays in 5 and 10 ampere ratings and clear plastic dust-tight enclosed 5 ampere relays are immediately available from stock. Specify dependable ELGIN performance... specify GH from your electronic parts distributor!

## SPECIFICATIONS

**NOMINAL POWER REQ.**—DC relays, 1 to 2 watts; AC relays, 2 to 3 volt amperes.

**NOMINAL VOLTAGE**—DC relays, 6 to 120 volts; AC relays, 6 to 220 volts. (On specification, DC voltage coil up to 220 volts or AC voltage coil up to 440 volts can be supplied.)

**RESISTANCE**—DC relays, 25 to 8,000 ohms; AC relays, 4 to 5,000 ohms.

**PULL-IN CURRENT VALUES**—7.2 Milliamps max. at 2,500 ohms; 5.0 milliamps max. at 5,000 ohms.

**DUTY CYCLE**—continuous.

**TEMPERATURE RANGE**— $-55^{\circ}$  to  $+85^{\circ}$ C when specified.

**INSULATION RESISTANCE**—100 megohms min.

**DIELECTRIC STRENGTH**—standard: 500 volts RMS. (When specified, 1,000 volts RMS can be met.)

**MAXIMUM WEIGHT**—2 ounces.

### GHA SERIES, 5 amp. open relay

Contact rating, 5 amps. resistive, 2 amps. inductive at 115 volts AC or 26.5 volts DC. Contact material is fine silver, 1C, 2C, 3C arrangements only. Relay is 1.1" high, 1.732" long and .937" wide. Contact terminals can be used as solder lugs or for printed circuitry.

(Also available: GHB series, 10 amp. open relay.)

### GHP SERIES, 5 amp. clear plastic enclosed relay.

Dust-tight plug-in. Contact rating, 5 amps. resistive, 2 amps. inductive at 115 volts AC or 26.5 volts DC. Contact material is fine silver, available in 1C or 2C arrangements only. Enclosure is  $2\frac{11}{16}$ " x  $1\frac{13}{32}$ " overall.  $2\frac{1}{8}$ " overall length above chassis.



## ELECTRONICS DIVISION

ELGIN NATIONAL WATCH COMPANY

2435 N. Naomi Street, Burbank, California



William S. Ivans, Jr.

ects. Subsequently, he supervised a number of new developments, including airborne mapping radar systems, long-range missile tracking and guidance, antennas, and radomes. He also gained extensive experience in research on basic aircraft and missile instrumentation systems and automatic equipment.

## Compton Labs Building Opens

MIT's \$4 MILLION new Compton Laboratories building is open. Equipment includes the IBM 704 computer, worth \$2.7 million and largest in any U. S. educational center.

The five-story structure adds 125,000 sq ft of floor space to MIT. It houses the Research Laboratory of Electronics, Laboratory for Nuclear Science, and Computation Laboratory.

Atop the building is a huge penthouse. There will be facilities for study of cosmic rays and radio waves. The computer fills a 46 by 70-ft room. A blackboard 48-ft wide is in the lecture hall. The building is named after Karl Taylor Compton, former MIT president and chairman.

## Two Engineers Join ECS Staff

DAVID BARNES and Martin Bondar have joined the engineering staff of Electronic Control Systems, Inc., Los Angeles, Calif. ECS is affiliated with Stromberg-Carlson and is



a subsidiary of General Dynamics Corp.

David Barnes was formerly with Electronic Corp. of America, and while attending MIT, worked with Philco Corp. in their co-op program. He is assigned to the Data Processing Section.

Martin Bondar has been associated with Hughes Aircraft and Hoffman Laboratories. Prior to joining ECS he was working at the Allen B. DuMont Laboratories. He is presently assigned to the Equipment Engineering Section.



Sam F. Arn

### Gertsch Appoints Arn To Sales Post

IN A general expansion at management level, president Elmer P. Gertsch has announced appointment of Sam F. Arn as general sales manager of Gertsch Products, Inc.

Arn, a senior member of IRE, and formerly in sales with the Lear Cal Division of Lear, Inc., will direct the national sales efforts of Gertsch representatives, and will set up a West Coast direct sales organization for the company. The company manufactures a broad line of precision electronic instruments and ratio transformers.

### Convair Advances Chief Design Engineer

CHARLES S. AMES, chief design engineer of Convair's intercontinental

# True Hermetic Sealing assures Maximum Stability

# in AMPERITE RELAYS and REGULATORS

Simplest • Most Compact • Most Economical

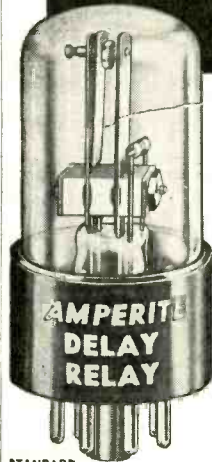

STANDARD



MINIATURE

## Thermostatic DELAY RELAYS

2 to 180 Seconds

- Actuated by a heater, they operate on A.C., D.C., or Pulsating Current.
- Hermetically sealed. Not affected by altitude, moisture, or other climate changes.
- SPST only — normally open or normally closed.

Amperite Thermostatic Delay Relays are compensated for ambient temperature changes from  $-55^{\circ}$  to  $+70^{\circ}$  C. Heaters consume approximately 2 W. and may be operated continuously. The units are most compact, rugged, explosion-proof, long-lived, and — inexpensive!

TYPES: Standard Radio Octal, and 9-Pin Miniature

**PROBLEM? Send for Bulletin No. TR-81**

Also — Amperite Differential Relays: Used for automatic overload, under-voltage or under-current protection.

## BALLAST REGULATORS

Amperite Regulators are designed to keep the current in a circuit automatically regulated at a definite value (for example, 0.5 amp.) ... For currents of 60 ma. to 5 amps. Operate on A.C., D.C., Pulsating Current.

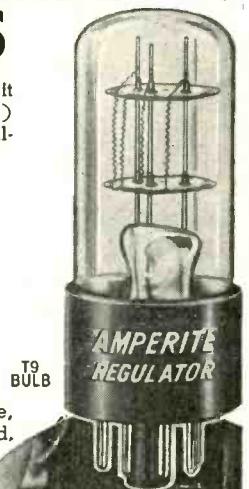
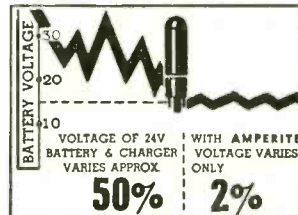
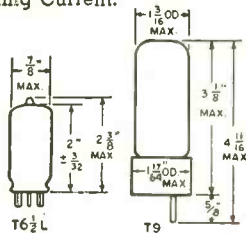

T9 BULB

Hermetically sealed, they are not affected by changes in altitude, ambient temperature ( $-55^{\circ}$  to  $+90^{\circ}$  C.), or humidity ... Rugged, light, compact, most inexpensive.

Write for 4-page Technical Bulletin No. AB-51

**AMPERITE CO., Inc.**

561 Broadway, New York 12, N. Y.

Telephone: CANal 6-1446

In Canada: Atlas Radio Corp., Ltd.

50 Wingold Ave., Toronto 10, Ontario.

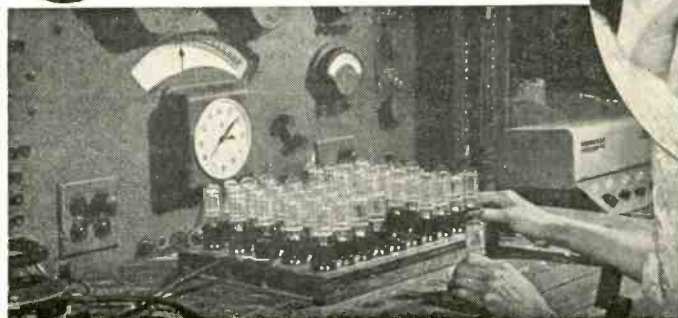

Individual inspection and double-checking assures top quality of Amperite products.



# RESEARCH IN DATA PROCESSING

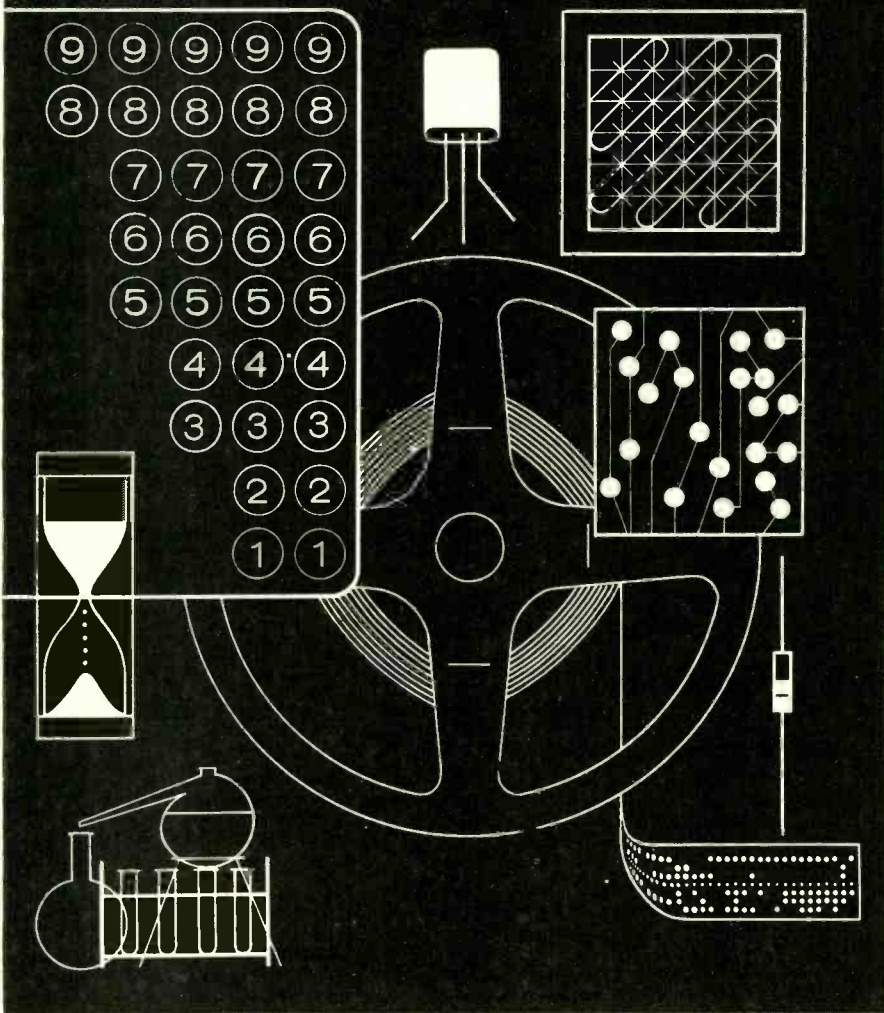

NCR Research offers exceptional opportunity to men with strong experience in the digital computer industry.

Many important openings exist in both basic and development phases of computer and data processing componentry. NCR uses the team approach to solving problems in physical chemistry, ceramics, and solid state physics involving magnetics, ferroelectrics, phosphors, photoconductors, electrolumines-

cence, crystal structure, memory devices, and non-mechanical printing.

Challenging projects in electronics also need men with new ideas and superior know-how for systems analysis, switching circuits, logical design, indication media, random access, input and read-out devices.

These men should have one or more degrees in the fields of electrical or electronic engineering, physics, chemistry, ceramics or mathematics.

**INVESTIGATE** NCR's research program! We have other interesting openings.

Write or wire: Director of Scientific Personnel, Section ME, The National Cash Register Company, Dayton 9, Ohio.

# NCR

THE NATIONAL CASH REGISTER COMPANY

ballistic missile program since its beginning in 1946, has been named chief project engineer for the Atlas ICBM at Convair-Astronautics.

Ames currently is on special assignment at the Air Force Missile Test Center, Patrick Air Force Base, Florida. He will be replaced by Lloyd Munson, a design engineer at Convair-Fort Worth. Munson has aided in the design of the Convair B36 intercontinental bomber, the B58 Hustler and other heavy aircraft.

## Metals & Controls Opens West Coast Facility

To EXPAND technical service to the aircraft and guided missile industries, Metals & Controls Corp. of Attleboro, Mass., has opened a West Coast design engineering facility. Its work will be to engineer supplementary actuating systems for KLIXON miniature precision switches in aeronautical and electronic applications.

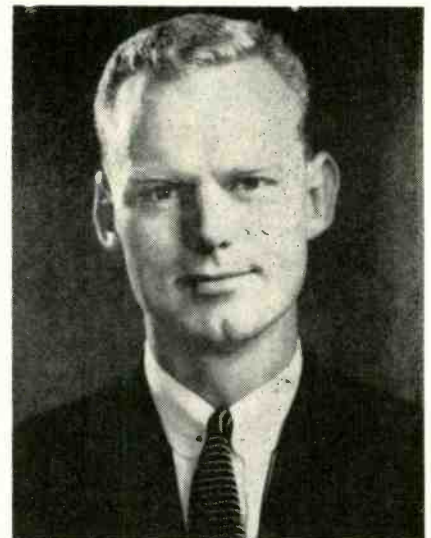

William Jones

William Jones will head the Los Angeles laboratory and office staff as project engineer.

## Andersen Labs Moves To New Quarters

A NEW, modern building at 501 New Park Ave., West Hartford, Conn., now houses Andersen Laboratories, Inc. The location provides additional facilities for manufacturing



ultrasonic delay lines and for increased research in the electronic field.

Andersen Laboratories have pioneered in ultrasonic and special electronic equipment for six years. Particular emphasis has been centered on components for the radar, computer and airborne control field.

### Chief Engineer Named at L&K Ltd.



Ray Clinton

LEWIS AND KAUFMAN, LTD., Division of International Glass Corp., has appointed Walter Raymond Clinton chief engineer in charge of research, design, and development relating to Los Gatos brand electron tubes.

In 1953 he joined Penta Laboratories in Santa Barbara, Calif., with responsibilities in v-t and twt development. Later he was affiliated with the GE Microwave Laboratory as a design engineer on twt development.

### GPL Opens New Test Lab

A 23,200-SQ FT environmental test building was recently opened by General Precision Laboratory on its 69-acre property at Pleasantville, N. Y.

Under construction since April, 1956, the \$450,000 structure increases the company's testing facilities for military and commercial

# In 1956, TOWER supplied over one hundred major Microwave Installations



- Mid-Continent Broadcasting Co.
- Television Station KSAZ
- Radio Station KFYR
- Radio Station WWTV
- Amalgamated Wireless Ltd., Australia
- Collins Radio Co.
- General Electric
- Lenkurt Electric Co.
- Motorola, Inc.
- Page Communications Engineers, Inc.
- Philco Corp.
- Radio Corporation of America
- Raytheon
- Western Electric
- American Telephone & Telegraph Co.
- Bell Telephone Laboratories
- Colorado Interstate Gas Co.
- Michigan Bell (SAGE project)
- Mid Valley Pipe Line
- Ohio Power Co.
- Southwestern Bell Telephone Co.
- U.S. Air Force

## with Towers, Reflectors and Buildings

*tower fabricators and erectors the world over*

# TOWER

CONSTRUCTION CO.  
SIOUX CITY, IOWA

**WRITE TODAY FOR FREE BOOKLET**



TOWER CONSTRUCTION CO.  
2710 Hawkeye Dr., Sioux City, Iowa

Please send me FREE copy of "Aluminum Reflectors"

Name \_\_\_\_\_

Firm \_\_\_\_\_

Address \_\_\_\_\_

City \_\_\_\_\_ State \_\_\_\_\_

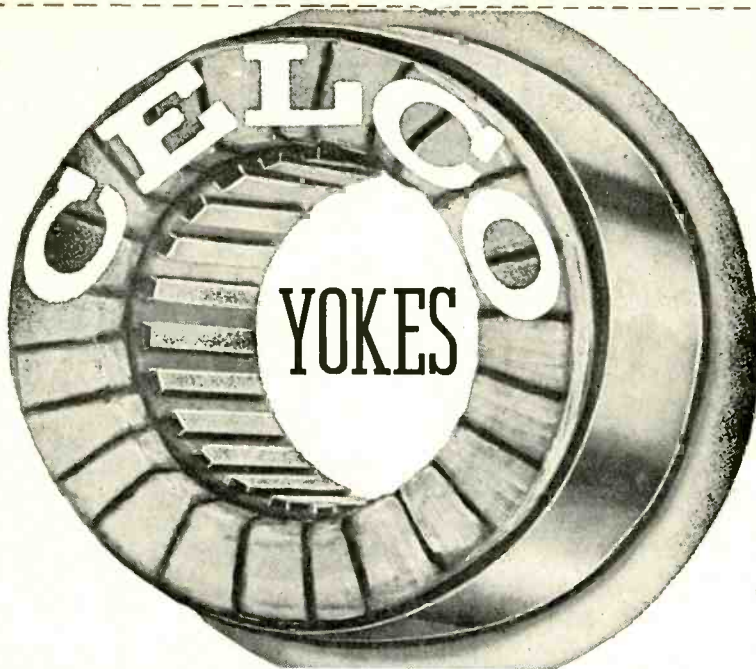

## FOR HIGH ACCURACY DISPLAY SYSTEMS

We specialize in the design and manufacture of precision deflection Yokes for military and commercial applications. Phone or write for immediate engineering evaluation of your critical display problems — Phone DAvis 7-1123. MAHWAH, N. J.



**Celco** Constantine Engineering Laboratories Co.  
MAHWAH, NEW JERSEY

Circle 239 Readers Service Card

## Physicist Joins Philco Computer Group



Dr. Morris Rubinoff

DR. MORRIS RUBINOFF, associate professor in electrical engineering at the University of Pennsylvania, has joined the Government & Industrial Division, Philco Corp., as manager of digital computer engineering. His duties will include future research and development of TRANSAC, Philco's new completely transistorized large scale data processing system.

## Daystrom Hires Otis As Systems Engineer

MANNY OTIS, formerly with the USAF Cambridge Research Center's Computer Laboratory, has become associated with the Systems Division of Daystrom, Inc., La Jolla, Calif., as a systems engineer.

While at Cambridge, Otis worked on magnetic-core memory devices, logic and equipment for a radar data-processing digital device, and

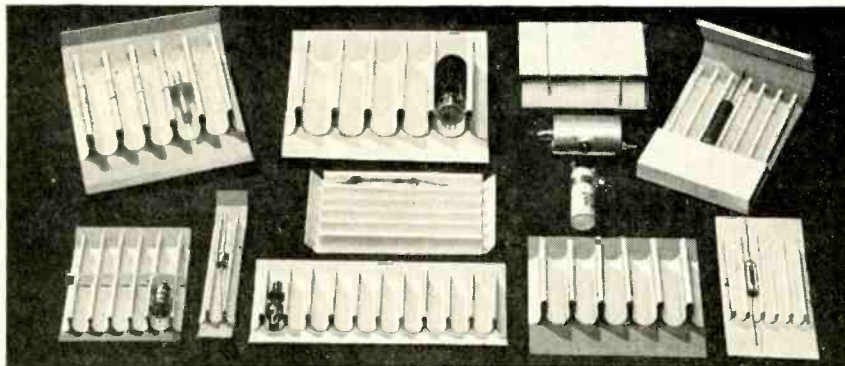

## PROTECT Delicate ELECTRONIC COMPONENTS While Handling in Production and Shipment with RONDO

RONDO, a cardboard device, holds and protects inserted objects by the spring-clip action of its fluted partitions. Easy to load and handle. Various sizes and styles have been developed for many parts, such as tubes, resistors, capacitors, diodes, fuses, etc., with diameters from 8 to 26mm and up.

Maximum efficiency and economy are accomplished when the same RONDO device is used throughout production, storage, shipping and display. RONDO is a paper product, sold at paper prices.

Send for leaflet and suggestions regarding your specific packing need.

RONDO PROCESS AND DESIGNS ARE COVERED BY PATENTS IN ALL MAJOR COUNTRIES



RECOGNIZED ALL OVER THE WORLD

**AMERICAN RONDO CORP.**, 100 SANFORD ST., HAMDEN 14, CONN

Representatives: C. S. Shotwell, 602 Levering Ave., Los Angeles · Brown & Scratch, 664 North Michigan Ave., Chicago





Manny Otis

the improvement of digital computer components. At Daystrom he is specializing in logical design of individual systems utilizing magnetic and transistor components, and the development of digital circuits.

## New Loral Plant Marks Company Growth

LEON ALPERT, president of Loral Electronics Corp., announces completion of its new 1½ million dollar plant building consisting of 100,000 sq ft of single-story floor space on 5 acres of land. The new plant is located at 825 Bronx River Ave., Bronx, N. Y.

## SMPTE Has New Staff Engineer

THE APPOINTMENT of J. Howard Schumacher, Jr. to the post of staff engineer for the Society of Motion Picture and Television Engineers has been announced. His present position is laboratory technician for NBC Development. He has been associated with NBC for 12 years.

## Airpax Locates in Florida

CENTRAL ENGINEERING DIVISION of Airpax Products Co., Baltimore, Md., is now located in Fort Lauderdale, Fla. The new air-conditioned building includes 14,000 sq ft of

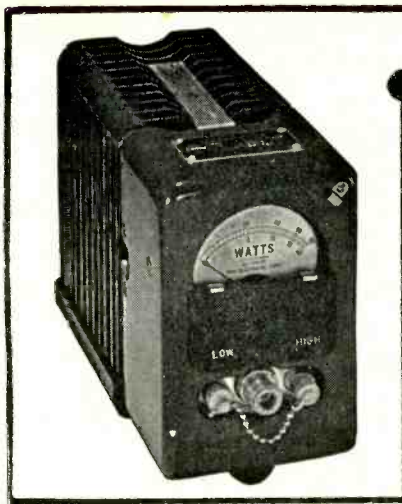

## TERMALINE DIRECT READING R. F. WATTMETERS

(DUAL RANGE)

MODEL 611—0-15 and 0-60 Watts

MODEL 612—0-20 and 0-80 Watts

IMPEDANCE—51½ Ohms

Models 611 and 612 are popular instruments in research and design laboratories, vacuum tube plants, transmitter manufacturing plants, and in fixed and mobile communication services.

They are ruggedly built for portable use, and are as simple to use as a D.C. voltmeter. The power absorbing load resistor is non-radiating, thus preventing transmission of unwanted signals which interfere with message traffic in communication services.

Frequency range: 30 to 500 MC (30 to 1,000 MC by special calibration)

Impedance: 51.5 OHMS—VSWR less than 1.1

Accuracy: Within 5% of full scale

Input connector: Female "N" which mates with UG-21 or UG-21B. Adapter UG-146/U is supplied to mate with VHF plug, PL259.

Special Scale Model "61s" are available as low as ½ watt full scale, and other models as high as 5 KW full scale.

Catalog Furnished on Request



# BIRD ELECTRONIC CORP.

1800 EAST 38TH ST., CLEVELAND 14, OHIO  
TERMALINE Coaxial Line Instruments

VAN GROOS  
COMPANY  
Sherman Oaks, Cal.

Visit us at the Wescon Show Booth 1708.

Circle 241 Readers Service Card

how to get  
more volts  
per pound  
at high  
altitudes

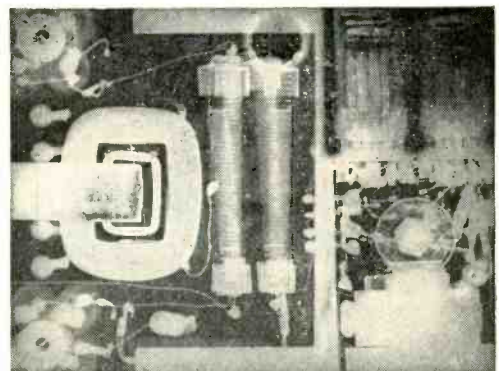

**PROBLEM:** Design a regulated high-voltage dc power supply for operation at high altitudes. Specifications:

- Input voltage—400 cps ± 10%
- Output—dual: 4 KV at 2.5 ma; 8 KV at .3 ma
- Regulation—no load to full load within 1%
- 105 cubic inches maximum
- Light as possible.

**SOLUTION:** We designed a vacuum tube regulator circuit, with the regulator tubes kept at low voltage. Result: The tubes could be mounted externally—for easy replacement.

For compactness and to protect high-voltage components against the hazards of moisture or rarefied air, we cast the rest of the unit in epoxy resin.

The assembly weighs only 6½ lbs., occupies 96 cu. in., plus terminals.

This sort of engineering can be at your service too. When you need electronic assemblies—by hundreds or thousands—straightforward or special design—make use of our production and design experience and facilities.

## CALEDONIA ELECTRONICS AND TRANSFORMER CORP.

Dept. E-8, CALEDONIA, NEW YORK

In Canada: Hackbusch Electronics, Ltd., 23 Primrose Ave., Toronto 4

one reliable source for all your

## CLIP, BLOCK and HARNES STRAP needs!

ADEL offers the widest variety of LINE SUPPORTS in the World . . . 19,000 different types and sizes for safe, vibration-free, positive support in all types of aircraft, missiles, rockets, ordnance, automotive and original equipment of all kinds.

SAFETY . . . FLEXIBILITY . . . DURABILITY . . .  
ECONOMY . . . SERVICE FITTED . . . SERVICE  
TESTED . . . SERVICE APPROVED

Illustrated are but a few of the World's most complete line of Line Supports that meet or exceed all applicable specifications and/or requirements. Whatever the application—STANDARDIZE ON ADEL—the leader in completeness of line, service and reliability.

Reliability  
**ADEL** PRECISION  
PRODUCTS  
A DIVISION OF GENERAL METALS CORPORATION

SPECIFICATIONS ARE AVAILABLE TO AIRCRAFT,  
MISSILE AND ORIGINAL EQUIPMENT MANUFACTURERS . . . WHAT ARE YOUR REQUIREMENTS?

Direct inquiries to Huntington Division  
1444 Washington Ave., Huntington 4, W. Virginia  
DISTRICT OFFICES: Burbank • Mineola  
Dayton • Wichita • Dallas • Toronto

Circle 243 Readers Service Card

## ELIMINATE RHODIUM PLATE REJECTS!



## **Sel-Rex**® RHODEX produces compressively stressed deposits

permitting heavier Rhodium electroplate than ever before possible. The photograph shows a film of Rhodium plate, produced with RHODEX, from which the basis metal was dissolved. Note the continuous unimpaired surface. We tried this experiment with leading competitive Rhodium formulations—the plate fell to pieces at a touch of the pencil. No special "know-how"—you can duplicate this demonstration in your own laboratory, with RHODEX. No cracking, no peeling...even in thickness exceeding one thousandth of an inch. Send for details.

Precious Metals Division

**SEL-REX CORPORATION**  
Nutley 10, New Jersey (Offices: Detroit, Chicago, Los Angeles)

Manufacturers of Exclusive Precious Metals Processes, Metallic Power Rectifiers, Airborne Power Equipment, Liquid Clarification Filters, Metal Finishing Equipment and Supplies.

laboratory and production space, as well as offices.

In moving to Florida, the division is expanding its production facilities to meet the growing market for special missile components. Additional engineering and technical personnel are being recruited to undertake further component and equipment development.

## RCA Encourages Science Teachers

A DEFINITE shortage of qualified teachers in science and mathematics, particularly in high schools situated in grass-roots areas, has been revealed in surveys conducted by RCA. Based on its findings, selection was made of 20 colleges and universities for new company scholarships to encourage students entering the science teaching profession. In all, 30 such scholarships, involving \$22,000, will be financed by RCA for the academic year 1957-58.

## Farley Named Chief Electronics Engineer at Canoga



Edward J. Farley

CANOGA CORP., Van Nuys, Calif, has appointed Edward J. Farley as chief electronics engineer. Employed by Canoga for the past two years, he formerly held the position of special projects engineer for electronics.

Prior to joining Canoga, he was



project engineer on MSQ 1-A Air Force ground guidance radar MSQ 1-2.

### Rehler Named to New Post

KENNETH M. REHLER has been appointed manager of the Data Processing Section at Electronic Control Systems, Inc., the West Los Angeles affiliate of Stromberg-Carlson and a subsidiary of General Dynamics Corp. He will be responsible for analysis design and development of special purpose analog and digital computers for commercial and military data processing applications.

Rehler has been in the computer field since graduating from MIT. Formerly with Raytheon, he was later vice-president of Computer Control Co., Inc.

### Beckman Promotes Del Duca



Anthony Del Duca

APPOINTMENT of Anthony Del Duca as chief electronics engineer for the Process Instruments Division of Beckman Instruments, Inc., has been announced. Formerly a senior engineer, he will direct the

## UNEQUALED PERFORMANCE IN

- TELEMETERING
- GUIDED-MISSILE MONITORING
- RADIOSONDE RECEPTION

This Special Purpose Receiver is an improved version of the NEMS-CLARKE 167-J1 and 167-J2. This new Receiver incorporates the best qualities of both of the former types plus many new features including a BFO. A video bandwidth control is provided to greatly improve signal-to-noise ratio when full bandwidth is not needed. It is especially useful as a high quality general purpose laboratory receiver.

## NEMS-CLARKE

INCORPORATED

919 JESUP-BLAIR DRIVE  
SILVER SPRING, MARYLAND

For further information write  
Dept. H-8



## TYPE 1501 SPECIAL PURPOSE RECEIVER

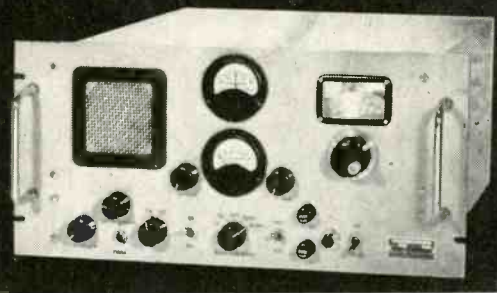

### SPECIFICATIONS

Type of reception.....	AM, FM, or CW
Tuning range.....	55-260 mc
IF bandwidth.....	300 kc
Sensitivity (measured without band-restricting filters).....	8 uv produces at least 23 db S/N ratio with 100-kc deviation, 400-cycle modulation.
Noise figure.....	11 db, maximum
IF rejection.....	Not less than 70 db
Image rejection.....	Not less than 40 db below 130 mc; 30 db minimum at any frequency.
FM output.....	0.15 volt per kc deviation (Approx.)
AM output.....	12 volts for 10 uv input modulated 30% at 1000 c.p.s. (Approx.)
Squelch.....	Operates on monitor circuit

Circle 245 Readers Service Card

# Brew Delay Lines meet exacting specifications

Whatever your delay line requirements, from prototype to large scale manufacture of production units, Brew offers you the design-engineering experience and complete facilities to supply your most exacting specifications.

Brew Delay Lines are custom made to your requirements and are available covering an extremely wide range of characteristics. A Laboratory Report accompanies every prototype showing your specifications and the characteristics of the prototype.

Send us specifications on your requirements or send for your copy of catalog 54.

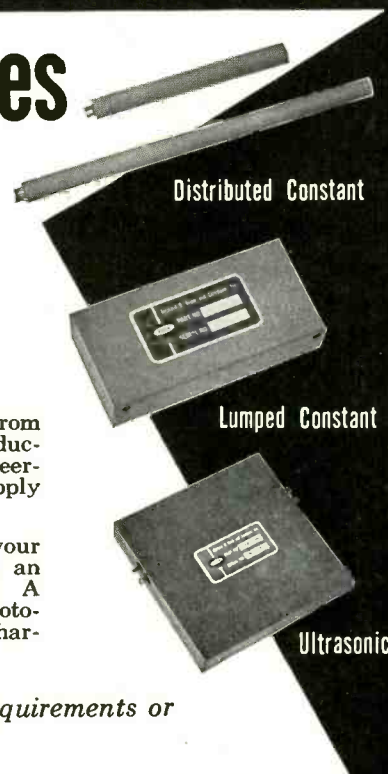

## Richard D. Brew and Company, Inc.

Concord, New Hampshire

design • development • manufacture



# EISLER VERTICAL SPOT WELDERS

MADE IN SIZES 1/2-1-2-3-5 KVA

WITH OR WITHOUT TRANSFORMER OR TIMER

Sent to Any Radio Tube Manufacturer in U.S.A. on a 30 Day Free Trial Basis.

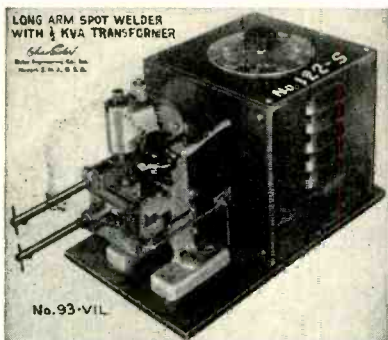
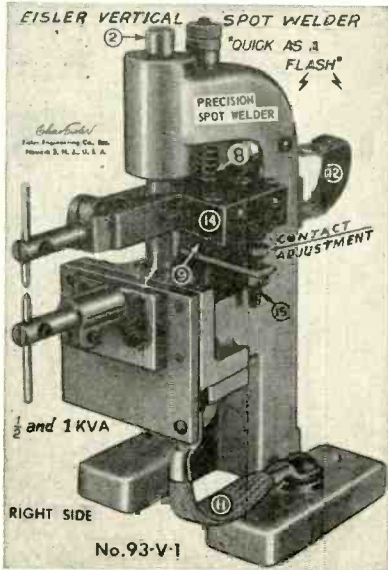

## TRANSISTOR MAKING EQUIPMENT

### DIODE MACHINERY AUTOMATIC OR SEMI-AUTOMATIC

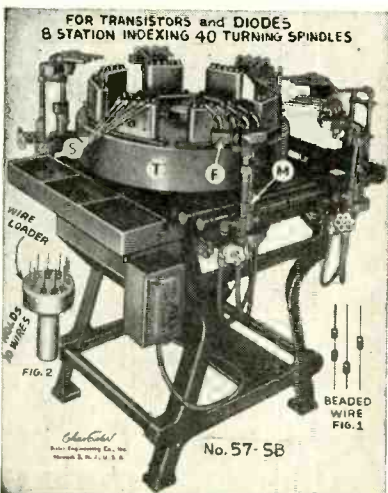

Send for Catalog Dr. Chas. Eisler, M. E. Founder CHAS. EISLER, JR., PRES.

## EISLER ENGINEERING CO., INC.

751 So. 13th St. NEWARK 3, N. J.  
Circle 247 Readers Service Card

design of electronic circuitry for a variety of instrumentation developed for the monitoring and control of industrial processes, ranging from chemical and petroleum operations to atomic power facilities.

Del Duca was previously employed by Noth American Aviation in the design and development of fire control radar circuitry. His experience also includes development of guided missile circuitry for the Convair Division of General Dynamics Corp.

## Freeman Joins General Ceramics

GENERAL CERAMICS CORP., Keasbey, N. J., manufacturers of industrial ceramics for the electrical and electronics industries, announce the appointment of James Robert Freeman to the engineering staff of the company's memory core products division. Freeman, formerly a staff member of MIT's Lincoln Laboratory, will act as a technical consultant to better serve customers on the West Coast.

## Government Honors Colson Engineer



Melvin Martins

MELVIN MARTINS, an electronics engineer at the Colson Corp., Elyria, Ohio, has been cited by the U.S. Department of Commerce for his

## PRECISION PAPER PART PROBLEMS?

— NIEMAND BROS. have the ANSWERS!

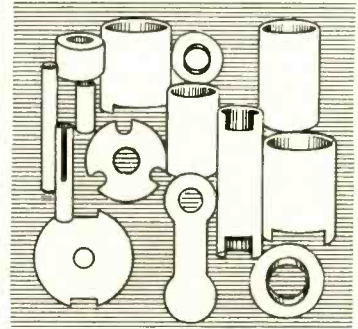

Many manufacturers have found the answers to problems of reducing unit costs and speeding up production by using Niemand Bros. Paper Tubular Products.

They're practical—buy them in the quantities you need in the materials you want—high dielectric kraft, fish paper, foils, special protective coated and laminated papers and Mylar\*. Printed or plain, they're made in diameters from .093" to 2" and up.

And, also available from Niemand Bros. are precision drawn paper or Mylar\* caps in diameters from .141" to 2", as well as die cut washers and custom parts.

\*DuPont's reg. trade mark for its polyester film.

Send for complete details.



## NIEMAND BROS., INC.

37-03 THIRTY-FIFTH AVENUE  
LONG ISLAND CITY 1, N. Y.

Specialists in Paper Tubes  
Products for Electrical Applications

RAVENSWOOD 8-0909

Circle 248 Readers Service Card

August 1, 1957 — ELECTRONICS



part in the development of a new instrument for the Census Bureau. A gold medal for exceptional service was awarded to Martins by Secretary of Commerce Sinclair Weeks.

The instrument he developed transcribes census data brought in from the field into language that can be fed to Univac, the electronic brain. Martins is a member of the engineering and design staff of Colson's Electronic Hospital Equipment Division.

### GE Names Johnson To New Post



M. R. Johnson

APPOINTMENT of M. R. Johnson as manager of the newly established Armament & Control Section of the Light Military Electronic Equipment Dept. has been announced. In his new post Johnson will have responsibility for manufacturing operations of the new Section located at Johnson City, N. Y., and its engineering facilities at Schenectady, N. Y.

Prior to his present appointment, he was manager-engineering of the Light Military Electronic Equipment Dept., a position he had held since 1952.

### Mullard Increases Transistor Capacity

THE first stage of the Mullard Ltd. factory designed solely for the

Circle 249 Readers Service Card

**NOW** we can meet the demand for

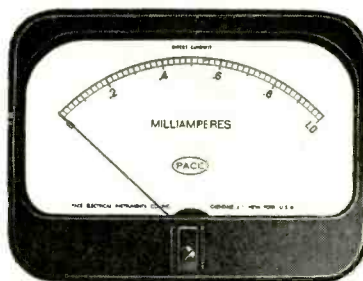

**METERS!**  
2" TO 7" SIZES

Expanded plant . . . increased staff . . . New, improved automation techniques . . . to meet the demand of electronic equipment manufacturers for custom produced panel meters, in production quantities.

**PACE** meters are manufactured under rigidly controlled climatic conditions to meet critical specifications as to sensitivity, resistance, damping, response time, illumination, scaleplate design, etc.

Send for latest illustrated catalog, available upon request. Write, wire or phone for applications engineering, consultation and assistance!



a Division of Precision Apparatus Co., Inc.  
70-31 84th Street, Glendale 27, L.I., N.Y.  
Export: Morhan Exporting Corp., 458 Broadway, N.Y. 13, N.Y.

Little Mag says . . .

"DID YOU KNOW THAT  
**MAGNATRON** IS HELPING  
'BUILD A FENCE  
AROUND YOUR BACKYARD?'"

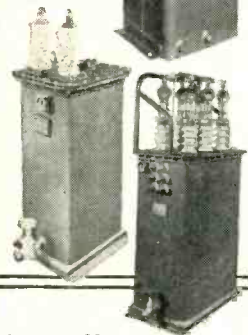

The Distant Early Warning (DEW) radar picket line is that safety fence. Its performance must be absolutely dependable.

Magnatran heavy duty components including unitized rectifiers, are the "standard" power supplies in the vital transmitters completing the system.

Whenever you require reliability and dependability you too can use.

Magnatran transformers.



**MAGNATRON** incorporated

P.O. Box 211 KEARNY, NEW JERSEY, U.S.A.

See page 39  
'56 Electronic Buyers Guide

Circle 251 Readers Service Card

## AUGAT'S NEW TRANSISTOR CLIPS

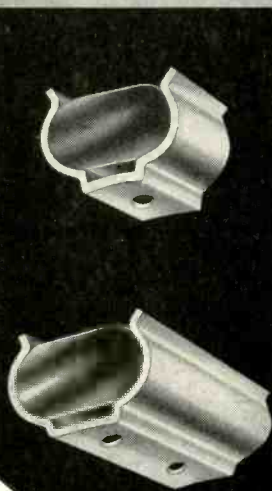

Augat Brothers have developed a new line of clips for the retention of transistors, crystals, diodes, etc.

Now available in all standard sizes, they are the answer to the engineers' layout problems in regards to shock and vibration. Made of either 1065 spring steel or 25 alloy beryllium copper to retain shape, a minimum of clamping action is lost in use.

If your requirements are not listed in our catalog, write us for information on clips made to your specifications.

**AUGAT BROS. INC.**  
31 PERRY AVENUE • ATTLEBORO, MASS.

Circle 252 Readers Service Card

manufacture of semiconductors has been completed at Millbrook Trading Estate, Southampton, England.

Occupying 75,000 sq ft, this first section is only one-third of the total plant. The plant eventually will employ 1,500 to 2,000, with a planned annual output of several million semiconductor devices by 1958.

The new factory is a self-contained center containing research, development and application laboratories as well as manufacturing facilities, although basic research into transistor problems will still be carried out at the central Mullard Research Laboratories located elsewhere in the south of England.

### Del Electronics Names New Executive



Hugo J. Di Giovanni

HUGO J. DI GIOVANNI has joined Del Electronics Corp., Mt. Vernon, N. Y., in the capacity of vice-president and chief engineer. He was formerly director of the Technical Liaison Division of the New York Office of the Atomic Energy Commission.

Di Giovanni was chief engineer at the X-Ray Division of North American Philips Co., Inc. At Del Electronics Corp. he will be responsible for the development of new products.

### Ram Moves to Larger Quarters

IN RESPONSE to increasing military and industrial demand for engi-



## D-B broad band gas-filled cavity wavemeters

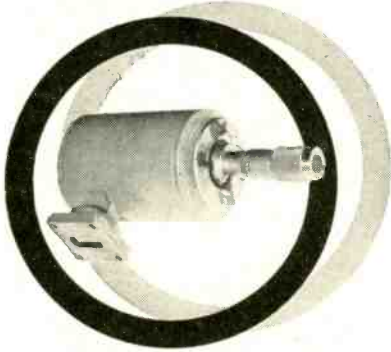

Each instrument covers a wide segment of the total range. Only 11 sizes serve from 2.6 KMC to 90 KMC. Accuracy is so high they may be used as secondary standards. Nitrogen filled and sealed for long life and high Q. Bi-metallic structure provides high degree of thermal compensation. Write for literature.



780 South Arroyo Pkwy. • Pasadena, Calif.  
Circle 253 Readers Service Card



## SPADE BOLTS

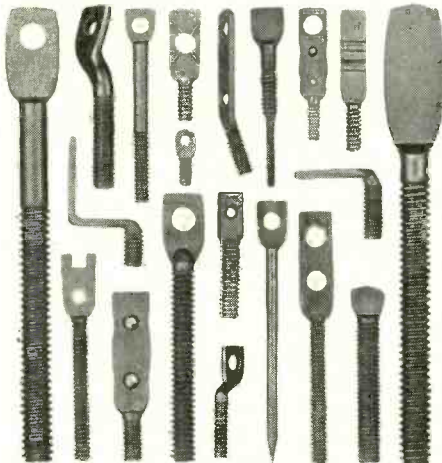

Specialists in designing and manufacturing of all-purpose fasteners and wire forms. Tooling to produce over 1000 styles in any screw size, material, finish, quantity, to your specifications.

Serving Industry for Thirty-Five Years  
— OTHER PRODUCTS —

## Simplex WIRE STRIPPERS & CUTTERS

• TOOLS • DIES • STAMPINGS

Bulletins on complete line on request

**WENCO MANUFACTURING CO.**  
1133 W. Hubbard St., Chicago 22, Ill., U.S.A.

Circle 254 Readers Service Card

ELECTRONICS — August 1, 1957

PLANTS AND PEOPLE

(continued)

neering and production know-how for inductors of all kinds—as well as greater service industry demand for the company's tv sweep components—Ram Electronics has expanded its engineering and production facilities and has moved to new and larger quarters at 600 Industrial Ave., Paramus, N. J.

The new plant is 22,000 sq ft on one level, on a 3½ acre plot. It accommodates 250 employees and is easily expandable as the necessity arises.

## Varo Starts New Division



Fred P. Granger

ESTABLISHMENT of a transformer division with Fred P. Granger as general manager was recently announced by Varo Mfg. Co., Inc., Garland, Texas.

The new division will provide an integrated engineering and manufacturing facility for magnetic components. It is equipped to design and build transformer chokes, saturable reactors and magnetic amplifiers to specific requirements in addition to offering standard designs now in manufacture.

Mr. Granger is in addition vice-president in charge of customer relations for Varo. He has been with the company since 1949.

## Universal Transistor Products Takes Larger Plant

A FIVE-HUNDRED percent sales increase in two years has resulted in the acquisition of a new air-conditioned 12,500-sq ft plant for Uni-

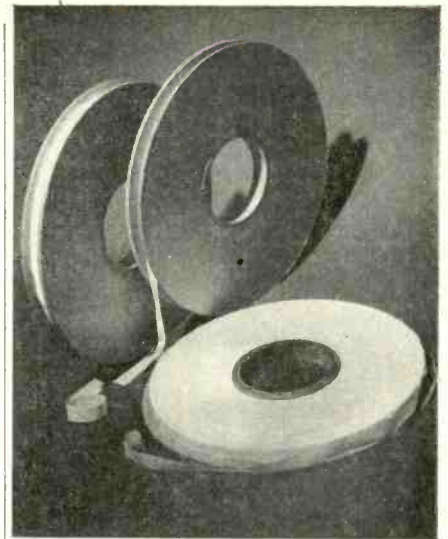

Dore'

**TAPE of  
TEFLON\***

**HAS 4**

**GREAT**

## ADVANTAGES:

- ① All tape spark tested to ASTM D149-55T
- ② Maximum Elasticity
- ③ Packaged to your specifications in continuous length rolls of maximum diameters handled by your wire wrapping machines.
- ④ Uniform Density

\*DuPont's Tetrafluoroethylene Resin

*John L. Dore', Co.*

5406 SCHULER • P. O. BOX 7772  
HOUSTON 7, TEXAS

• • • • •  
SALES AGENTS IN U.S.A.

**FOR JOHN L. DORE, INC.**

DuPont's Teflon • Hi Quality Nylon

Circle 255 Readers Service Card



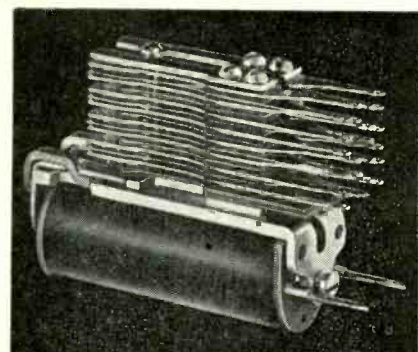

## New "E" Relay interchangeable with many other makes

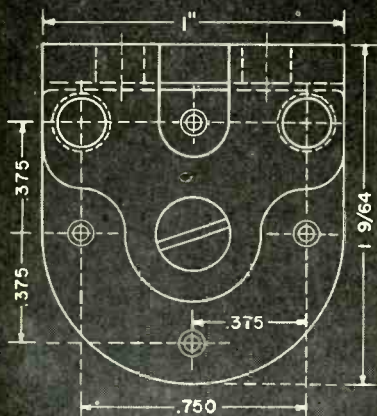

Stromberg-Carlson's new type "E" relay combines the time-proven characteristics of the type "A" relay with a mounting arrangement common to many other makes.

As the sketch above shows, our new frame mounting holes and coil terminal spacing allow you to specify these relays—of "telephone quality"—interchangeably with brands you have been using. Costs are competitive and expanded production means *prompt delivery*.

Welcome engineering features of the new "E" relay are—

- ★ Contact spring assembly: maximum of 20 Form A, 18 B, 10 C per relay.
- ★ Coil: single or double wound, with taper tab or solder type terminals at back of relay.
- ★ Operating voltage: 200 volts DC maximum.

You may order individual can covers in a choice of 3 sizes for the new relay, as well as for our type "A" and "C" relays.

For complete details and specifications on the "E" relay and other Stromberg-Carlson relays, send for your free copy of Catalog T-5000R.

## STROMBERG-CARLSON

A DIVISION OF GENERAL DYNAMICS CORPORATION  
TELECOMMUNICATION INDUSTRIAL SALES  
114 CARLSON ROAD, ROCHESTER 3, N. Y.

Circle 258 Readers Service Card

versal Transistor Products Corp. at 36 Sylvester St., Westbury, L. I., N. Y.

The company manufactures a wide variety of commercial and military transistorized power supplies ranging from low-power consuming units for radios and radiation detectors to high power units for rockets, missiles, microwave stoves and electronic flash units.

## Honeywell Appoints Semiconductor Manager



William W. Martenis

APPOINTMENT of William W. Martenis as manager of the semiconductor activities of Minneapolis-Honeywell Regulator Co. has been announced.

For a number of years, Martenis has been manager of Honeywell's new product extension activities. He will continue to handle these duties, in addition to being in charge of engineering, development, production and sales of the company's power-type transistors.

## Research Instrument Moves to Larger Quarters

THE RESEARCH INSTRUMENT Co., of Portland, Ore., has moved its operations to new and larger quarters at 7962 S. E. Powell Blvd., Portland 6, Ore. The new facilities provide an increase in working area of 400 percent including space for addi-

## WHEN ELECTRONIC PRODUCTION CALLS DANO COILS ANSWER!

Day after day, year after year, Dano has been continuously answering production's call for coils to customer specifications; . . .

"Can you make a series of specially treated coils to these specifications . . ."

"We need a quantity of vacuum impregnated coils to our detailed specifications enclosed . . ."

"Enclosed is our order for 10,000 coils to be made to our high temperature specifications . . ."

"Our production department must have encapsulated coils for a new electrical device . . . Please quote per enclosed blueprint."

Each a different coil requirement . . . and each answered by Dano with the exact type of coil needed.

If you need coils, try Dano for Bobbin, Form Wound, Paper Interleave, High Temp and Encapsulated Coils.

Transformers Made To Order.



Circle 257 Readers Service Card

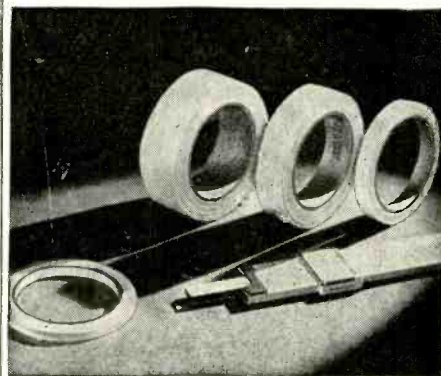

## TEMP-R-TAPE PRESSURE-SENSITIVE TEFLON TAPE

TEFLON tape with a silicone polymer adhesive backing. An easy-to-apply Class H insulation for slot lining, bundling, splicing, wrapping. Excellent adhesion, elongation and dielectric over entire -100°F to 400°F temperature range. 6 mil and 13 mil thick in rolls and sheets.

FREE SAMPLE and data sheet.

Write direct or use magazine inquiry card.

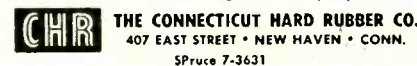

Circle 258 Readers Service Card

August 1, 1957 — ELECTRONICS



tional expansion. Plans call for continued expansion as new models of instruments and components are introduced to the field.

The new quarters will also house facilities for production of the new line of series 100 single turn precision potentiometers recently announced.

### Ford Instrument Names Two to Key Posts



Edward C. Wagner



Michael A. Moscarello

EDWARD C. WAGNER has been appointed to the new post of assistant to the vice president for engineering at Ford Instrument Co., Divi-

*Specialists in the Unusual*

## Anodized Aluminum Wire

To fill a need for high temperature insulation in a high conductivity wire. Precision drawn to close resistance control in the smaller sizes.

*Write for List of Products*

.0008" TO .030" DIAM. ←  
INSULATION AT 800° F. ←  
HIGH DIELECTRIC COATING ←

**SIGMUND COHN CORP.**  
121 SOUTH COLUMBUS AVE., MOUNT VERNON, N. Y.

Circle 259 Readers Service Card

## NEW IN-LINE DISPLAY

**WITH One-Plane Presentation**

Here is a new type of In-Line Display which incorporates several features never before available in units of this type. One outstanding feature is the one-plane presentation. All numbers and/or characters appear on the front surface of the display unit. Numbers are of uniform size and intensity, and excellent readability is insured from any angle of viewing.

The In-Line Display is available as a single unit, but may be assembled in groups of two, three, four, etc., as desired. The viewing screen, which measures 1½" wide and 2" high, extends the full width of the unit, so that the final assembly presents a continuous surface.

*Write for complete detailed specifications today.*

PRICE PER UNIT

**\$12.50**

QUANTITY PRICES ON REQUEST

The above illustration shows the In-Line Display when panel mounted. Notice the easy-to-read, one-plane presentation of the digits. Note also how the viewing screen affords a continuous surface for faster, easier reading.

**INDUSTRIAL ELECTRONIC ENGINEERS**  
*Engineers and Manufacturers of Fully Automatic Systems and Machines*  
3973 Lankershim Blvd. • North Hollywood, California

# MANDREL *x-y recorder*

**NEW** in design... the ER-90 x-y recorder draws curves in Cartesian coordinates. The pen moves on the x and y axes in accordance with DC millivolt signals applied to the x or y input terminals.

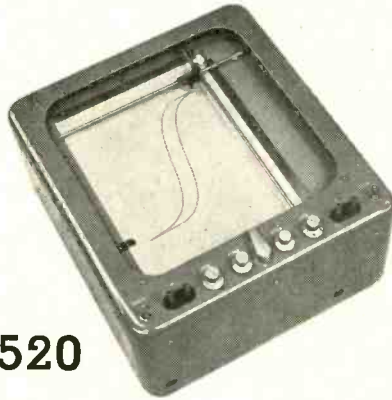

**\$520**

**useful for:**

- computer readout
- hysteresis curves
- semi-conductor and tube characteristics
- filter characteristics
- stress/strain; temperature/pressure, etc.

**DESCRIPTION:**

Servo type x-y recorder, employing conventional chopper amplifiers, 2 phase motors and potentiometer rebalance.

**FEATURES:**

Flat bed—full chart visibility. Simple, efficient design. Moderate cost.

**SPECIFICATIONS:**

*(Each axis. Axes are electrically independent.)*

SENSITIVITY	10 MV. per inch
INPUT RESISTANCE	10,000 ohms
PEN SPEED	7.5 inches per second—1 sec. Full Scale on y Axis
LIMIT OF ERROR	.75%
REPEATABILITY	.5%
CHART SIZE	Standard 8½x11 graph paper.

**MANDREL INDUSTRIES INC.**

**INSTRUMENTS DIVISION**  
5134 Glenmont Drive • Houston, Texas

Circle 261 Readers Service Card

sion of Sperry Rand Corp.

At the same time, Michael A. Moscarello was named engineering director for marine equipment.

## Schaner Joins The Daven Co.



**Frederick A. Schaner**

RECENTLY announced by The Daven Co., Livingston, N. J., is the appointment of Frederick A. Schaner as chief engineer. Previously employed as manager, receiver engineering, Research and Development Division of Air Associates, Inc., he was responsible for research and development of subminiature, automatically and fixed tuned receivers for aircraft and missile data link systems.

## New Rheem Plant Established

RHEEM Electronics Division is now fully established in its new facility at 7777 Industry Ave., Rivera, Calif. The new plant is devoted exclusively to electronics and provides space for research, development and fabrication of test equipment as well as design and production of airborne and laboratory electronic instrumentation units.

## Chipp Joins FTL

APPOINTMENT of Rodney D. Chipp as manager of systems engineering for the radio communication laboratory of Federal Telecommunication Laboratories, Nutley,

August 1, 1957 — ELECTRONICS

**What's new in Precision "POTS"?**



MULTITURN



ROTARY



LINEAR



GANG



SECTOR

**send for new Precision Potentiometer catalog**

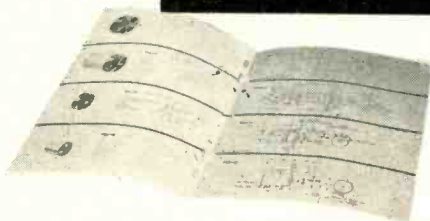

For 25 years a supplier of mechanical and electro-mechanical controls for home, industry and the military.



**GENERAL CONTROLS POTENTIOMETER DIVISION**  
801 ALLEN AVENUE, GLENDALE 1, CALIFORNIA

Circle 262 Readers Service Card



## MEGACYCLE METER

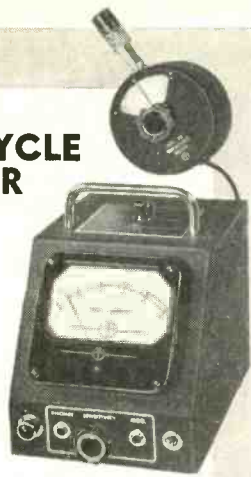

For determining the resonant frequency of tuned circuits, antennas, transmission lines, by-pass condensers, chokes, etc. For measuring inductance and capacitance. May also be used as an auxiliary signal generator, and in many other applications.

Available in the following frequency ranges:

Model 59-LF	0.1 to 4.5 Mc
Model 59	2.2 to 420 Mc
Model 59-UHF	420 to 940 Mc

*Laboratory Standards* 

**MEASUREMENTS CORPORATION**

BOONTON • NEW JERSEY

Circle 263 Readers Service Card

# COSMIC

ELECTROLYTIC & PAPER  
TUBULAR

## Condensers

35 YEARS OF  
"PROVEN  
DEPENDABILITY"

COSMIC CONDENSER CO.  
853 Whittier St., Bronx, N. Y.  
PHONE  
LUdlow 9-3360

Circle 264 Readers Service Card

ELECTRONICS — August 1, 1957



Rodney D. Chipp

N. J., has been announced.

He will be in charge of advanced planning in the radio communication laboratory, which will require liaison with both military and commercial communication agencies. In addition, he will coordinate the system engineering of the various radio communication projects. He was formerly director of engineering for the manufacturing divisions of Allen B. DuMont Laboratories, Inc.

### Kansas Company Incorporates

CAL-OHM Laboratories, manufacturer of precision electronic components, recently announced incorporation of the company under a State of Kansas charter.

The company presently is in production on precision wire-wound resistors, trimming and 10-turn potentiometers, Wheatstone bridges and decade resistance boxes. It also offers research and development for the solving of specific electronic instrumentation problems, or production to specifications of electronic components.

General offices and main plant of the company are in Sterling, Kansas.

### Nichols Named Chief Engineer for Taylor Instrument

A FORMER director of research for Taylor Instrument Companies,



GUDEBROD  
BROTHERS  
ARE  
PIONEERS  
IN FLAT  
& BRAIDED  
TAPES OF  
NYLON,  
DACRON,  
TEFLON.

WAX-COATED,  
FUNGUS-PROOF,  
HEAT-RESISTANT.

Gudebrod flat braided lacing tapes hold harness securely—no bite-through or slip, yet are easy on the hands. Some resist high temperature, some are color-coded . . . and they come wax-coated or wax-free . . . rubber-coated . . . or with special coating. Gudebrod makes many tapes for many purposes, including defense work. Send us your lacing problems or your specifications . . . we can supply the answer to both.

**GUDELACE • GUDE-NYLACE  
GUDELACE H • TEFLACE**

**GUDEBROD BROS. SILK CO., INC.**

**ELECTRONICS DIVISION**

225 W. 34th St., New York 1, N. Y.

**EXECUTIVE OFFICES**

12 South 12th St., Philadelphia 7, Pa.

Circle 265 Readers Service Card

**End Printed Circuit bugaboos!**  
with ALPHA #346 Flux



**ALPHA**  
printed circuit  
**FLUXES**

*maximum activity — flux purity . . .*  
solves major dip soldering problems

Pressing and costly problems such as partly soldered joints, low insulation resistance, limited reliability — which threaten finished product performance, are now being solved with Alpha Printed Circuit Fluxes made of pure water white rosin and solvents featuring effective activating agents. Alpha printed circuit fluxes exceed Federal Specs. QQ-S-571b and MIL S-6872.

These fluxes have been specially developed for printed circuit work where instant wetting and excellent capillary action, combined with a moderate drying rate is necessary.

Technical Bulletin #2 has complete story.  
Send for it today. Write Dept. CT.



IN CHICAGO, ILLINOIS  
ALPHA-LOY CORP.

**OTHER ALPHA PRODUCTS**

Cored and Solid Wire Solders  
High Purity Metals . . . Soft Solder Preforms

Circle 266 Readers Service Card

Rochester, N. Y., has rejoined the organization after an absence of several years. He is Nathaniel B. Nichols, newly appointed to the position of chief engineer. He succeeds Ralph E. Clarridge, who has been appointed to the president's staff as specialist for new product lines.

Nichols left the Rochester company to become professor of electrical engineering at the U. of Minnesota. He subsequently joined Raytheon as assistant v-p and manager of commercial engineering. During the war he worked with MIT.

**Mack Electronics Names  
Director of Engineering**



Wendell E. Phillips

APPOINTMENT of Wendell E. Phillips as director of engineering for Mack Electronics Div., Inc., of Plainfield, N. J., has been announced. Before joining Mack Electronics, Phillips served as engineering section manager of Air Associates, Teterboro, N. J., for the past 6 years. Prior to that he held engineering positions with the Lavoie Laboratories and the Federal Television and Radio Corp.

**Bendix Computer Div.  
Doubles Plant Size**

THE nation's fourth largest manufacturer of electronic computers, Bendix Computer Div., Bendix Aviation Corp., recently completed



**It's new!**  
**NICOTE Metallized  
Ceramic  
Coating**

• Now for the first time you can successfully use a *single* metallic coating for refractory ceramic bodies which provides a surface for applying *either hard or soft* solders with melting points between 275° and 1600°. With NICOTE, no expensive preliminary processing is necessary. It's ideal for hermetic and mechanical seals and vacuum applications. Bulletin 155 contains complete details. Write for a copy.

**frenchtown**

**PORCELAIN COMPANY**

86 Muirhead Avenue • Trenton 9, N. J.  
National Representatives: Lunday Associates  
694 Maia St., Waltham 51, Massachusetts  
Circle 267 Readers Service Card

**Lepel**

**HIGH FREQUENCY**  
*Induction*

**HEATING UNITS**



**BRAZING  
ANNEALING  
HARDENING  
SOLDERING  
MELTING**

LEPEL Electronic Tube  
GENERATORS—1 KW; 2½ KW;  
5 KW; 10 KW; 20 KW; 30 KW; 50 KW;  
75 KW; 100 KW  
LEPEL Spark Gap Converter  
2 KW; 4 KW; 7½ KW; 15 KW; 30 KW.

WRITE FOR THE NEW LEPEL CATALOG . . . 36 illustrated pages  
packed with valuable information.

All Lepel equipment is certified to comply with the  
requirements of the Federal Communications Commission.

**LEPEL HIGH FREQUENCY  
LABORATORIES, INC.**

55th STREET and 37th AVENUE, WOODSIDE 77,  
NEW YORK CITY, N. Y.

Circle 268 Readers Service Card

August 1, 1957 — ELECTRONICS



doubling the size of its main plant at 5630 Arbor Vitae St., Los Angeles, Calif. The additional provides space for expanded administrative, marketing, engineering and production facilities.

A feature of the new addition will be an enlarged computer center, equipped with two Bendix G-15D general purpose computers and two Bendix DA-1 digital differential analyzers to be available to firms on a rental basis.

### Servomechanisms Gets New Components Division

A NEW component division for Servomechanisms, Inc., has been announced. Known as the Vacuum Film Products Division, it is located in El Segundo, Calif., and occupies 5,500 sq ft.

The new division will be responsible for the development and manufacture of electronic components utilizing vacuum deposition techniques. The application of this technique will stress the development of high temperature miniaturized electronic circuit components.

### Raytheon Names Division Manager

HARVEY J. FINISON has been appointed manager of Raytheon



Harvey J. Finison

# TELREX LABORATORIES

Designers and Manufacturers of

## COMMERCIAL SERVICE "BEAMED-POWER" ARRAYS

Calibrated for the commercial 13 to 14 mc. band. Other frequencies available.

Model Illustrated No. CX-13-14

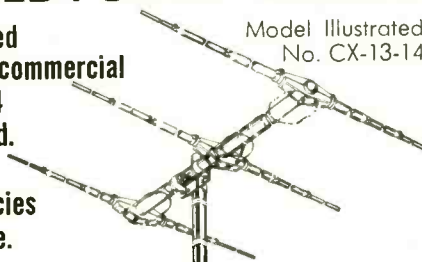

Precision Tuned, Matched and Calibrated for easy assembly and repetition of our Specifications at your site, providing optimum gain per element and hi-signal-to-noise, hi-signal-to-interference "Balanced Pattern."

Electrical Specifications: Gain 8 db, F/B ratio 28 db, V/S/W/R 1.2/1 or better! Impedance, 52 ohm thru coaxial halfwave "Balun" (supplied). Power capacity 5 KW - Higher power models available at extra cost.

Mechanical Specifications: Wt. 60 lbs., 3" OD x 26 ft. boom, taper swaged elements, tapering from 1 3/8" OD to 1/2" OD, incorporating stainless steel hardware, "Borg-Warner" Cycolac moldings, 1/4-20 S.S. junction terminals and heavily cadmium plated mounting plate. Wind surface area: 7 sq. ft. Wind load at 100 mph: 210 lbs.

Price \$338.00 f.o.b. Asbury Park, New Jersey Available three (3) days after receipt of order. Descriptive literature on request.

Telrex is equipped to design and supply to our specifications or yours, Broad-band or single frequency, fixed or rotary arrays for communications, FM, TV, scatter-propagation, etc.

Consultants and suppliers to communication firms, universities, propagation laboratories and the Armed Forces.



ASBURY PARK 25  
NEW JERSEY, U.S.A.  
Tel. PRospect 5-7252

Circle 269 Readers Service Card

## BEST BY DESIGN

### Not by Chance

Constant attention to the wants and needs of users, has been worked into the finished recorder by trained designers, who devote their entire effort to producing the best in direct-writing recorders. *E-A Recorders are designed to be the best.* Performance has proved their superiority.

Ask for Catalog 657



PRODUCT REPRESENTATIVES IN MOST PRINCIPAL CITIES

## The ESTERLINE-ANGUS Company, Inc.

Pioneers in the Manufacture of Graphic Instruments

Dept. E5, P. O. Box 596, INDIANAPOLIS 6, INDIANA

# PHILLIPS HERMETIC SEALS

The Man from Phillips is the man to see for glass-to-metal seals — any type, any size, any quantity, standard or custom-engineered. Exceptionally fast delivery. Write for catalog.

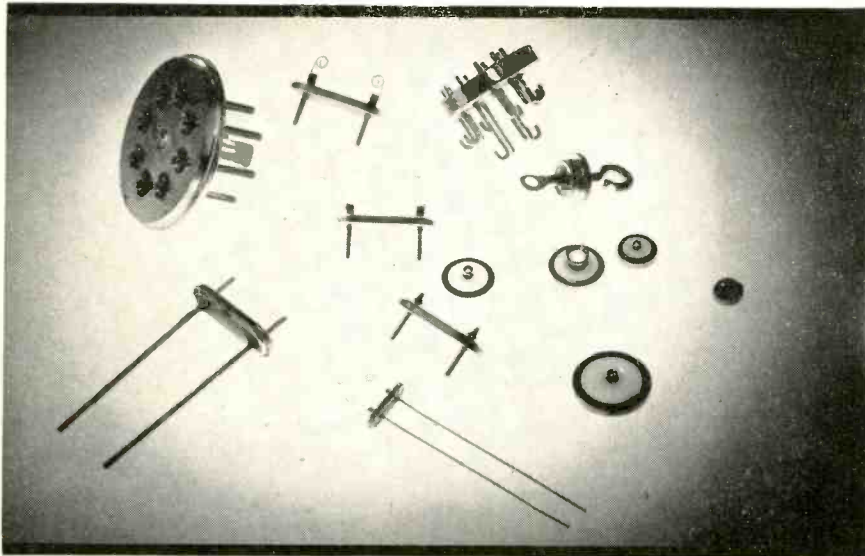

**Phillips Control Corporation, Joliet, Illinois** — AN ALLIED PAPER CORPORATION  
SUBSIDIARY — SALES OFFICES: NEW YORK - PHILADELPHIA - BOSTON - SAN FRANCISCO - DENVER - SANTA MONICA - WASHINGTON - WINSTON SALEM - CLEVELAND - DALLAS - SEATTLE - KANSAS CITY - ST. LOUIS - DETROIT  
Circle 271 Readers Service Card

# YOKE

**SPECIALISTS**

**COMPLETE LINE for every Military and Special purpose.**

- Yokes for 7/8", 1-1/8", 1-1/2", 2-1/8" neck diameter CR tubes.
- Rotating and fixed coil designs.
- Core material to suit your requirements.

Special test instruments can establish your yoke deflection parameters to an accuracy of  $\pm 0.1\%$ .



Series aiding field and parallel (bucking) field designs.

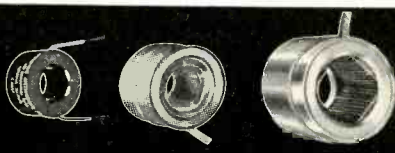
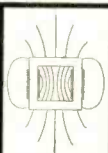

Consult Dr. Henry Marcy on your new applications today.

*syntronic*

**INSTRUMENTS, INC.**

170 Industrial Road • Addison, Ill. • Phone: Terrace 4-6103

62-8511

Manufacturing Company's semiconductor division. He will direct division activities at the firm's two plants in Newton and a third in Brighton, Mass. He reports directly to N. B. Krim, vice-president of the firm's receiving and cathode-ray tube operations.

Before joining Raytheon, Finison served as business consultant to the management services division of the Arthur D. Little, Inc., and as director of engineering and executive vice president of the National Pneumatic Co. and Holtzer-Cabot divisions of Boston.

## M-H Aero Guidance Engineers Move

MINNEAPOLIS-HONEYWELL has completed the transfer of most of its inertial guidance engineering effort to the firm's new Aeronautical Division facility at St. Petersburg, Fla.

The staff in Florida now numbers more than 300, and is scheduled to reach more than 500 by the end of the year. Construction of the 90,000-sq ft engineering facility was begun last fall. It is the first phase of a proposed \$4-million plant that will be devoted solely to design and manufacture of inertial guidance systems and components.

## Electromation Co. Names Chief Engineer

APPOINTMENT of Glen E. McClure as chief engineer of Electromation Co., Santa Monica, Calif., was recently announced.

Associated for several years with Hoffman Laboratories, McClure was instrumental in the design of numerous military electronic devices marketed by Hoffman. He is also credited with design of a 250-tube electronic memory device for Standard Coil Products Co., Los Angeles.

McClure won recognition for his design of r-f elements of the TACAN portable beacon simulator for Hoffman Labs. Earlier, he served as chief electrical engineer for Schwein Engineering Co.



## New Books

### VHF Television Tuners

By D. H. FISHER  
*Philosophical Library Inc., New York,*  
 1957, 133 p, \$6.00.

IN the young and rapidly advancing field of television tuners, this is the first book ever published which covers design considerations as well as production and servicing problems. Mr. Fisher has put together a coherent and readable account of the theoretical and practical aspects of the subject in a relatively small book.

► **Standards**—Although the proposed performance criteria and general specification of vhf television tuners are pertinent to the British standards, they apply equally well to the American standards in a broad sense. As a matter of fact, the basic philosophy of tuner design in Europe, according to this book, has been faithfully following the American practice with only minor deviations.

Mr. Fisher logically divided the tuner into three parts—signal-frequency amplification, frequency converters and oscillators. In connection with signal-frequency amplification, he presents an excellent treatise on shot and thermal noises at very high frequencies.

However, the author fails to emphasize the importance of matching between antenna and signal-frequency amplifier under all signal conditions and at any frequency within the signal passband. This has been a profound design criterion of tuners for use in color television receivers.

► **Cosmic Noise**—Furthermore, the problem of cosmic or galactic noise is only superficially mentioned. Its effect on design considerations of recent American vhf television tuners is missing. For instance, at channel 1 of Band I in England or channel 2 in this country, the galactic noise is of such a magnitude, at all times, that the noise factor of the television tuner is relatively unimportant unless it exceeds 10 db. Therefore, the best tuner design at lower vhf is not to secure the lowest noise factor, but

rather to maintain a condition of optimum signal transmission from the aerial to the television tuner.

The author's treatment on frequency converters is more or less conventional, aiming at the best conversion gain and noise factor. The critical property of harmonic formation in frequency converters is again missing.

Finally, the discussion on frequency stability of local oscillators is inadequate since analytical approaches to this vital problem have been published in the American literature. These inadequacies, however, are made up quite sufficiently by the systematic and complete description of production and servicing techniques.

The chief criticism of this book, in the reviewer's opinion, is that the references given are insufficient to satisfy most readers.

In general, Mr. Fisher's book is well organized and clearly written. The material is carefully arranged and integrated. The complicated problem of a television tuner is described in simple language with the aid of little mathematics. For these reasons, it is extremely easy to read and is an excellent choice for readers seeking a broad knowledge of vhf television tuners. On the other hand, it will not fulfill the needs of those who are looking for advancements in this field.—  
 WEN YUAN PAN, *RCA Victor TV Division, Cherry Hill, N. J.*

### Automation In Business And Industry

By EUGENE M. GRABBE  
*John Wiley & Sons Inc., New York,*  
 1957, 611 p, \$10.00.

THE University of California offered a course in the spring of 1955 which consisted of a series of lectures by prominent engineers and scientists covering the most recent developments in the field of automation and their applications. This volume is the publication of these lectures and represents the efforts of 21 authors.

The usual advantages and disadvantages of a book written by many

**PRECISION  
 ATTENUATION  
 to 3000 mc!**

**SINGLE "in-the-line"  
 ATTENUATOR PADS  
 and 50 ohm COAXIAL  
 TERMINATIONS**



PROTECTED UNDER STODDART PATENTS

This new group of pads and terminations features the popular Types C and N connectors, and permits any conceivable combination of the two styles.

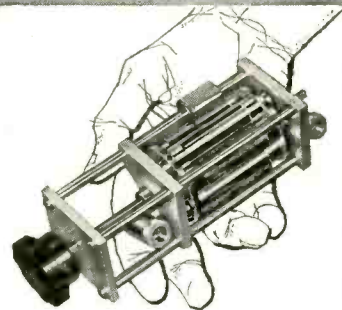

PROTECTED UNDER STODDART PATENTS

*six-position*  
**TURRET ATTENUATOR**

- Frequency Range: dc to 3000 mc.
- Characteristic Impedance: 50 ohms.
- Available Attenuation: Any value from 1 db to 60 db.
- Accuracy:  $\pm 0.5$  db.
- Power Rating: One watt sine wave power dissipation.

**STODDART**

*Aircraft Radio Co., Inc.*  
 6644-A SANTA MONICA BLVD.  
 HOLLYWOOD 38, CALIF. • HO 4-9294

Circle 273 Readers Service Card

Revolutionary, New

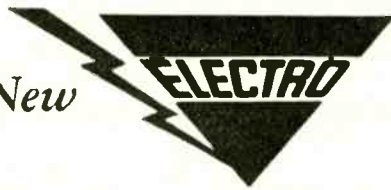

Epoxy Resin Potted  
PERMANENTIZED TRANSFORMERS

custom built to your specifications

GOOD OVERLOAD FACTORS

EXTREMELY RUGGED

GOOD LOOKING

INEXPENSIVE

LOW LOSSES

HIGHLY RELIABLE

LOW TEMPERATURE RISE

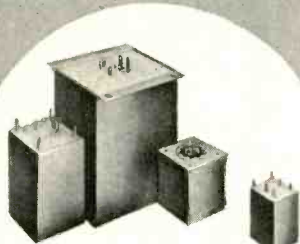

New formula developed by Electro makes possible *reduced size* and more *rugged* construction in resin-potted transformers. New potting material welds core, coil, case, and terminals, with permanent bonding to case. Built to withstand 170° C.

May be qualified under MIL-T-27A, grades 1, 2, 4, or 5 in class R, S, or T, as well as commercial specifications.

**ELECTRO ENGINEERING WORKS, INC.**

401 Preda St., San Leandro, Calif. • In Metropolitan Oakland area

ON DISPLAY IN WESCON BOOTH 1717

Circle 274 Readers Service Card

**NEW GENERAL PURPOSE RELAY**  
(SERIES 130 RELAY)  
THE MOST USEFUL RELAY FOR INDUSTRIAL APPLICATION

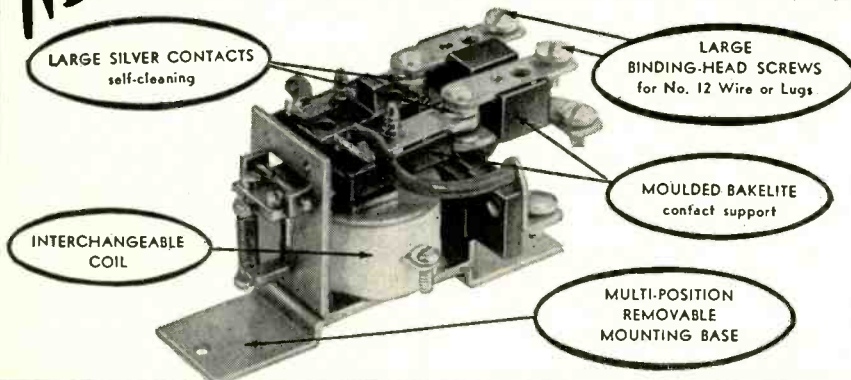

**NO OTHER RELAY IS SO VERSATILE**

**SPECIFICATIONS**

CONTACTS	RATINGS	COILS	MOUNTING BASE
Single-and-double pole	20 amp. at 115 V	AC & DC to 230 V	Metal strap or bakelite.
Single-and-double throw	60 Cy. AC or 24 V DC	(Interchangeable)	Base can be rotated 90 degrees either direction for mounting convenience.
Aux. DT contacts available	U.L. Approved	Power—2 watts	

**DIMENSIONS** Base—1" x 3 7/8"  
Request complete data on Series 130 Relay.

*Wheelock* SIGNALS  
INC.

RELAYS



LONG BRANCH, N. J.

authors can be found here. For example, the coverage is quite broad; included are such diverse subjects as Nyquist's stability criteria and the social impact of automation. However, there is much repetition of introductory material and the technical level is quite variable throughout.

The large field of coverage and the rather general treatment gives the book the appearance of a handbook on automation; because of this, it should make a very good reference for engineers and managers, especially for those who are contemplating the first giant steps towards the introduction of automation techniques or systems into their particular fields of endeavor.

Very few readers will find the entire volume of interest, but very many readers both from engineering and management should find various sections of the book to be helpful. Which sections will depend upon the reader's technical background and his particular interest in this young but vast subject.

► **Past and Future**—The book opens with some historical background and presents the implications of the future introduction of more automation upon our society and our technology. Next follows a series of general definitions of terms used in the field and an introduction to the language of automation. The section on feedback control systems is more technical than the preceding sections and includes a fairly extensive discussion of such topics as various stability criteria, transient response of control systems and examples of automation in industry today.

A very informative presentation of instrumentation controls is contained in Chapter 5 followed by a chapter which introduces analog computers to the reader. The section on digital computers is quite comprehensive and serves to introduce the chapter on data processing which discusses the uses of digital computers as well as the requirements of data processing equipment for various applications.

A section on analog-to-digital conversion units is followed by a brief account of input-output equipment and associated peri-



**NEW CHRISTIE**  
**SILICON**  
**POWER RECTIFIERS**



**For Top Reliability**

- A standard line from 30 to 1000 amps
- Closely regulated by magnetic control
- Voltages: 8-16-32-36
- Stationary or Mobile Types
- For Missile, Aircraft, Lab & Factory

Write for Latest Bulletins on  
 Silicon & Selenium Power Rectifiers

**CHRISTIE ELECTRIC CORP.**  
 Dept. EL, 3410 W. 67th St., Los Angeles 43  
 Over a Quarter Century of  
 Rectifier Manufacturing

Circle 276 Readers Service Card

pheral off-line equipment. The solutions to some large volume information-handling problems using large-scale digital computers are considered in Chapter 11. The application of control systems to the automatic control of flight, the subject matter of Chapter 12, serves as a good illustration of the capabilities of automation techniques. The reader is also introduced to some typical sensing and actuating elements at this point.

The mechanization of the fabrication of electronic assemblies is used to exemplify the potentialities of automation for the fabrication industries. It is pointed out that the fabrication industries have lagged behind the processing industries in applying automation techniques.

After presenting the role of analog computers in industrial control systems and the use of digital control of machine tools, the authors offer additional examples of automatic production systems used in today's manufacturing industries.

► **Management Aspects**—In Chapter 17 the reader is led away from the technical aspects of automation by a discussion of some of the problems facing management and engineering due to the introduction of automation. The next chapter is devoted to a discussion of the economics of the application of automation in industry along with a consideration of some of the effects of automation upon management, industry and society in general. Although automatic control methods have been technically developed, some very important factors in our society have retarded the use of automation. Those discussed here include lack of industrial capital, ignorance of the availability of new devices, and plain management inertia. The wise industrialist will examine this presentation carefully.

► **Future**—Certainly one of the most interesting and original contributions of this work is its last chapter entitled "The Future of Automation". Here the author quite convincingly shows the superiority of the overall systems ap-

**Tough**  
**Heyco Nylon**  
**STRAIN**  
**RELIEF**  
**BUSHINGS**

Insulate and anchor the  
 power supply cord to  
 your housing . . .

no need for grommets,  
 wire knots or costly  
 labor.

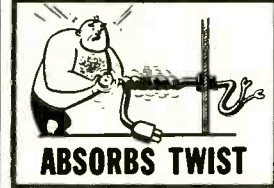

Send for samples to fit your wire, today!

**HEYMAN**  
**MANUFACTURING COMPANY**  
 KENILWORTH 2, NEW JERSEY

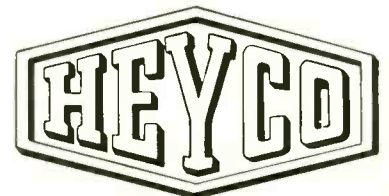

**HEY MAN!**  
 ...SAY HEYMAN

Circle 278 Readers Service Card

**Earn Extra Income**  
 in **MOBILE-RADIO**  
**MAINTENANCE!**



It's now a big business (650,000 installations) . . . fast-growing (70% increase just last year) . . . specialized . . . and high-paying!

Learn how to turn this opportunity into cash—write today for free booklet "HOW TO MAKE MONEY IN MOBILE-RADIO MAINTENANCE!" It's published as a service to radio engineers by Lampkin Laboratories, Inc., manufacturers of the well-known 105-B Micrometer Frequency Meter and 205-A FM Modulation Meter.



105-B      205-A

**LAMPKIN LABORATORIES, INC.**  
 Instruments Div., Bradenton, Fla.

At no obligation to me please send "HOW TO MAKE MONEY IN MOBILE-RADIO MAINTENANCE."  
 Name \_\_\_\_\_  
 Address \_\_\_\_\_  
 City \_\_\_\_\_ State \_\_\_\_\_

Circle 277 Readers Service Card

**ARE YOUR  
COMPONENTS  
TEMPERATURE-  
CRITICAL?**

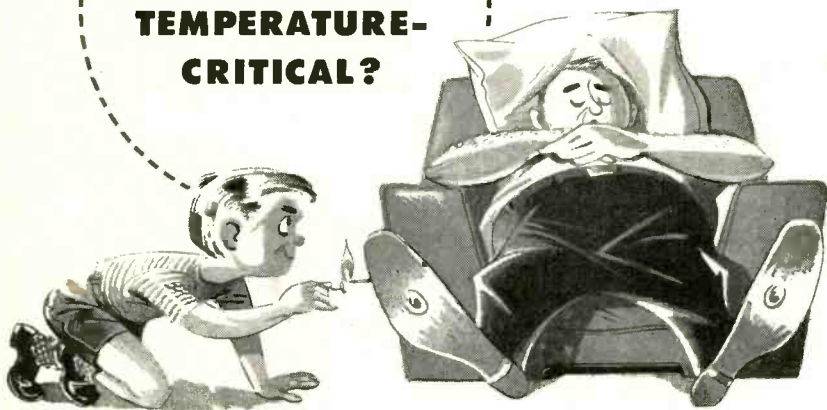

**SOLVE YOUR PROBLEMS  
WITH MONITOR  
COMPONENT  
OVENS**

Quality ovens in ranges of temperature stability from  $\pm 5^{\circ}\text{C}$  to  $\pm .01^{\circ}\text{C}$ . For use in ground or airborne equipment. Can be used to house thermocouples, transistors, standard cells, crystals, potentiometers and other critical components.

*Write, wire or phone us, today!*

**MONITOR**



**PRODUCTS COMPANY**

SOUTH PASADENA, CALIFORNIA • RYan 1-1174  
Circle 279 Readers Service Card

# RIBBONS • STRIPS

★ PURE TUNGSTEN  
★ MOLYBDENUM

★ THORIATED TUNGSTEN  
★ SPECIAL ALLOYS

and OTHER METALS  
IN

**ULTRA THIN SIZES**

to  
TOLERANCES CLOSER THAN COMMERCIAL STANDARDS  
by

## OUR SPECIAL ROLLING TECHNIQUE

Note: for highly engineered applications—strips of TUNGSTEN and some other metals can be supplied

**ROLLED DOWN TO .0003 THICKNESS**

- Finish: Roll Finish—Black or Cleaned
- Ribbons may be supplied in Mg. weights if required

**For HIGHLY ENGINEERED APPLICATIONS**

DEVELOPED AND MANUFACTURED BY

**H. CROSS CO.**

15 BEEKMAN ST., N. Y. 38, N. Y.  
TELEPHONE: WOrth 2-2044  
COrtlandt 7-0470

proach to the development of automation basing his remarks on an analogy between automation in business and industry and military electronics. He points out the inevitability of the importance of automation in the future of industry and the steps which business and industry must take to gain the major benefits of automation within the next eight to ten years.—  
D. E. ROSENHEIM, *IBM Watson Laboratory at Columbia University, New York, N. Y.*

## Les Semiconducteurs

BY G. GOUDET and C. MEULEAU  
*Eyrolles, Paris, France, 1957, 436 p, 5,720 fr.*

MUCH has been written about the transistor since its invention in 1948 by Dr. Shockley and his associates at the Bell Telephone Laboratories. It is difficult to conceive of a discovery that has attracted more widespread interest or immediate application.

Development of new types and applications of various semiconductor devices have occurred so rapidly as to make it difficult to follow. The present work satisfies a number of requirements. It is at once a highly theoretical treatment of the solid state physical properties of semiconductors, a well developed exposition of the characteristics of their behavior as determined by their internal and surface chemical constitution and a timely summary of the most recent applications in various circuits and under diverse physical influences.

► **Crystal Properties**—The theoretical study of crystal properties, the effects of impurities, the preparation of various combinations of germanium, silicon, selenium, etc., the velocity of surface recombination, crystallization by alloying, fusing or zone melting and by growing, preparation of *pn*, *npn* and other more complex junctions—these are but a few of the aspects of semiconductors treated.

As the title implies the work is truly a study of all forms of semiconductors such as diodes, triodes,





## All business is specialized

...and nothing specializes  
on your business like your  
business paper

This profit-wise peddler looks for the wettest crowds. His business is specialized. Like yours.

And like your business, this business paper of yours specializes, too. It packs into one place the current facts you want. It scouts out, sorts out, reports and interprets the specific news and information you need to keep posted and keep ahead in your field. Cover to cover, editorials and ads, it concentrates on bringing you specialized help you can't get anywhere else. Read it thoroughly ... and put it to work.

This business paper in your hand has a plus for you, because it's a member of the Associated Business Publications. It's a paid circulation paper that must earn its readership by its quality ... And it's one of a leadership group of business papers that work together to add new values, new usefulness, new ways to make the time you give to your business paper still more profitable time.

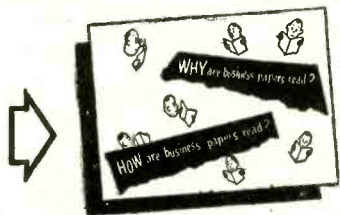

A copy of this quick-reading, 8-page booklet is yours for the asking. It contains many facts on the benefits derived from your business paper and tips on how to read more profitably. Write for the "WHY and HOW booklet." Room 2710.

**McGraw-Hill Publishing Company**  
330 W. 42nd St., New York 36, N. Y.

One of a series of ads prepared by  
THE ASSOCIATED BUSINESS PUBLICATIONS



tetrodes, varistors, gyrators, thermistors, power meters, infrared-ray modulators, etc. Additionally the development of the equivalent circuit both in grounded-base and grounded-emitter connections is covered.

There is also a very comprehensive bibliography which details on an international scale all publications relating to each chapter. This includes references from an early contribution in 1918 to the first part of 1956.

It is felt that for one desiring a single book in French which covers electron theory and practice this is a worthwhile title.—RALPH C. KENNEDY, *Adjunct Associate Professor of Physics, Hofstra College.*

## Modern Mathematics For the Engineer

By EDWIN F. BECKENBACH.  
*McGraw-Hill Book Co., New York,*  
1956, 514 p., \$7.50.

A SERIES of lectures on various mathematical topics, which have extensive application to engineering, was presented recently by the University of California. Each separate topic was delivered by a person prominent in that field. The resulting lectures have been incorporated into this book.

► **First Part**—The subjects covered are organized into three parts. The first emphasizes the various techniques for formulating solutions and constructing mathematical models. Thus its subject matter tends to include more of the classical methods of mathematics. In particular, problems involving linear and nonlinear differential equations, ballistics, the calculus of variations and the boundary value problems associated with partial differential equations are discussed.

► **Statistical Procedures**—The second part is mainly concerned with statistical procedures. Thus this section starts off with a presentation of N. Wiener's theory of prediction. This is followed by the theory of games, the various techniques of operations research and

quality ...  
uniformity ...  
service ...

**GLASS** for

HERMETIC SEALING

• EPOXY PREFORMS

• PRESSED  
CERAMICS

**mansol**  
CERAMICS CO.

140 LITTLE ST. • BELLEVILLE • NEW JERSEY  
THORNTON HEATH • SURREY • ENGLAND

Circle 286 Readers Service Card



Mc GRAW-HILL  
DIRECT MAIL LIST SERVICE

McGraw-Hill Mailing Lists  
Will Help You

- Merchandise your advertising
- Conduct surveys
- Get inquiries and leads for your salesmen
- Pin-point geographical or functional groups
- Sell direct
- Build up weak territories
- Aid dealer relations

Direct Mail is a necessary supplement to a well rounded Business Paper advertising program.

Most progressive companies allocate a portion of their ad budgets to this second medium at the same time as they concentrate on the best business publications. 600,000 of the top buying influences in the fields covered by the McGraw-Hill publications make up our 150 mailing lists. Pick YOUR prospects out of our Industrial Direct Mail catalogue.

Write for your free copy.  
It contains complete information.

to keep ahead,  
the leaders rely on leaders



Trio Model D  
AC VTVM in  
Packard-Bell's  
Missile Tester  
Console

**PACKARD BELL ELECTRONICS**  
designs-in with **trio**  
panel-mounting miniature  
electronic instruments

Write for **FREE ENGINEERING GUIDE**  
on Trio's complete line to Dept. E-8  
Trio Laboratories, Inc., Seaford, N. Y.

when ordinary instruments are  
too big or  
inadequate . . .

**trio**

Circle 281 Readers Service Card

## Electrical Coil Windings

For 40 years . . . specializing in all types of coils to customers' specifications. Design or engineering assistance available on request.

# COTO-COIL CO., INC.

SINCE 1917

65 Pavilion Avenue Providence 5, Rhode Island

Circle 282 Readers Service Card

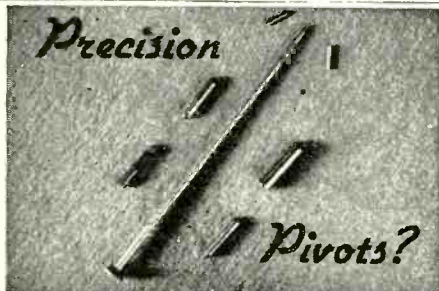

The "spike" in the center is a common pin.  
The others are VK precision pivots.

## Call VK

Steel, chromium plated, or carbide precision pivots to .013" diameter, 1 RMS or finer surface finish. Diameter tolerance to .000010". Chamfers, radii, lapped ends, etc.

Also volume production lapping of flat or round production parts.

Send us your specifications.

**The VAN KEUREN COMPANY**  
176-D WALTHAM ST. WATERTOWN, MASS.

Circle 283 Readers Service Card

dynamic programming and the Monte Carlo methods.

► **Computational Techniques**—The third part deals with the computational techniques that have had such great importance in modern engineering research and development. These include a discussion of matrices, integral transforms, conformal mapping, numerical methods of solving systems of differential equations and finally a description of analogue and digital computing systems.

This book suffers from the same fault that most books do which have a different author for each chapter. That is, it lacks continuity and a unified approach. Some chapters such as the one on dynamic programming by Richard Bellman are quite detailed and represent a comparatively thorough presentation of their subject matter. Other chapters in the book are somewhat cursory having very little development and illustration of the presented theory.

Moreover, the various authors presume different amounts of mathematical preparation on the part of the reader. For instance the first chapter on linear and non-linear oscillations by Solomon Lefschetz requires no more than a knowledge of the elementary theory of ordinary differential equations. On the other hand, Norbert Wiener presupposes a knowledge of the Lebesgue integral when discussing his theory of prediction. This is very unlikely if the reader is an engineer even though this is the type of person for which the book has ostensibly been written.

► **Unidentified Terms** — On page 76, Magnus R. Hestenes in discussing the calculus of variations mentions the positive definite quadratic form without stating just what this is. It is doubtful if the average engineer will have come across such a concept.

There are also instances of repetition in the material presented in different chapters.

Most of these flaws are due simply to the fact that the book has nineteen authors and they are perhaps inevitable.

The book has many well pre-



## How To Get Things Done Better And Faster

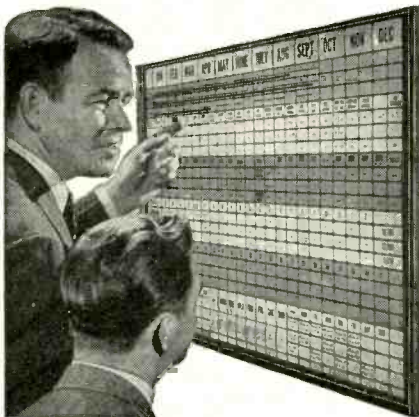

### BOARDMASTER VISUAL CONTROL

- ☆ Gives Graphic Picture—Saves Time, Saves Money, Prevents Errors
- ☆ Simple to operate — Type or Write on Cards, Snap in Grooves
- ☆ Ideal for Production, Traffic, Inventory, Scheduling, Sales, Etc.
- ☆ Made of Metal Compact and Attractive. Over 150,000 in Use

Full price **\$4950** with cards

**FREE**

24-PAGE BOOKLET NO. C-20

Without Obligation

Write for Your Copy Today

**GRAPHIC SYSTEMS**

55 West 42nd Street • New York 36, N. Y.

Circle 284 Readers Service Card

*Ideal for*  
**ANTENNA CONNECTIONS**  
**PHOTO-CELL WORK**  
**MICROPHONE CONNECTIONS**

# JONES

**SHIELDED TYPE**  
**PLUGS & SOCKETS**

P-101-1/4  
 S-101

LOW LOSS PLUGS AND SOCKETS FOR HIGH FREQUENCY CONNECTIONS. SUPPLIED IN 1 AND 2 CONTACT TYPES:

101 Series can be furnished with 1/4", .290", 5/16", 3/8" or 1/2" ferrule or cable entrance. Knurled nut securely fastens unit together. Plugs have ceramic insulation and sockets have bakelite. Quality construction. Fine finish. Assembly meets Navy specifications. For full details and engineering data ask for Jones Catalog No. CS-21

**JONES MEANS Proven QUALITY**

See us at the WESCON SHOW Booths 2703-04

**Howard B. Jones Division**  
 CINCINNATI MANUFACTURING CORPORATION  
 CHICAGO 24, ILLINOIS  
 SUBSIDIARY OF UNITED-CARR FASTENER CORP.

Circle 285 Readers Service Card

ELECTRONICS — August 1, 1957

NEW BOOKS

(continued)

sented sections on the various mathematical topics of interest to the engineer. When taken separately, they represent very good introductions to these topics considering their limited length. This is notably true, for instance, in the excellent chapter on matrices by Louis A. Pipes. His development is more thorough and has more examples than the similar chapter on matrices in his own book on applied mathematics for engineers and physicists. In short, the entire book is not suitable as a textbook for a course on engineering mathematics but it is very good as a reference for introductory material on any particular topic in it.—ARMEN H. ZEMANIAN, *College of Engineering, New York University.*

### Photoconductivity Conference

BY R. G. BRECKENRIDGE, B. R. RUSSELL and E. E. HAHN  
*John Wiley & Sons, Inc., New York, 1956, 653 p, \$13.50.*

THIS book presents the papers delivered at the Photoconductivity Conference at Atlantic City. In addition to the papers, some of the discussions are also included.

As is true of all books of this type, this collection is most valuable for those engaged in research in the field and it is not intended for those unfamiliar or only slightly familiar with the subject. It deals with the fundamental processes involved in photoconductivity and not with applications. There is no doubt in the mind of this reviewer that this book will be as useful to the man who applies photoconductivity to practical ends as to the research scientist, since it not only gives a thorough insight into the processes involved but also an excellent survey of the present state of scientific knowledge in the field and of the problems and materials which are currently in the foreground of interest.

Of course, all topics are not equally well discussed because all branches are not equally well represented at a meeting. This is the more so since the field of photo-

## To Exceptional Engineers ... Investigate the Exceptional Openings At Westinghouse BALTIMORE

Westinghouse-Baltimore, long the leader in the electronics field, has permanent career positions now open to the exceptional engineer. These are selective opportunities for superior engineers who have the qualifications in education and experience to accept the responsibility of advanced work. It may well be worth your while to investigate these special creative engineering openings. Why not write today for pertinent details—and arrange for a confidential interview.

Send for the Engineer's Career Book ... "NEW DIMENSIONS"

Here's an exciting new brochure that gives you a picturesque introduction to Baltimore and a behind-the-scenes tour of the Westinghouse-Baltimore operation.

Write to Dr. J. A. Medwin, Dept. 694, Westinghouse Electric Corporation, P.O. Box 746, Baltimore 3, Md. Please indicate your degree, year of graduation and field of interest. For a confidential interview please include a resume of your education and experience.

## Westinghouse BALTIMORE



Advanced Electronics Systems, Ordnance, X-Ray, Carrier Microwave, and Induction Heating Equipment for Military, Industrial, and Commercial Purposes.

An Engineer's Company





**RESEARCH**

# Electronic Engineers

**CAREER FULFILLMENT IS A MAXSON TRADITION**

Too often ability and ambition go unrecognized simply because an engineer is associated with an organization whose scope is too shallow to permit complete expression. We sincerely believe that the currently expanding activities of The W. L. Maxson Corporation offer the creative engineer a limitless range of assignments for career fulfillment.

**DEVELOPMENT**

Responsible positions now available in the fields of research and development. Kindly send resume and salary requirements to:

Mr. L. W. Albright  
Technical Placement Manager

**THE W. L. MAXSON CORPORATION**

460 W. 34th St.,  
New York 1, N. Y.

## PRECISION PLASTIC CAPACITORS AT COMPETITIVE PRICES!

**POLYSTYRENE and MYLAR\***

Capacitance	From .001 mfd to any value
Voltage	From 50 V.D.C. to 30 KV
Tolerance	Polystyrene From $\pm 0.1\%$ to $\pm 5\%$ Mylar* From $\pm 1\%$ to $\pm 10\%$

**SMALLEST CASE SIZES**  
**TUBULAR—BATHTUB—RECTANGULAR**

Very Good Deliveries \*DuPont T.M.

**PRECISION CAPACITORS, INC.**  
150 W. Cypress Ave. Burbank, Calif.

Circle 287 Readers Service Card

for complete selection of Basic Requirements for your Coil Winding needs it's ...

## Coil Winding Equipment Co.

write for complete technical literature

**COIL WINDING EQUIPMENT CO., Oyster Bay, New York**

Circle 288 Readers Service Card

conductivity has tremendously expanded, as becomes evident upon glancing through this book.

► **Major Sections**—The editors have skillfully arranged the subject into five major sections.

The first section gives an introduction into the phenomenological treatment of photoconductivity and a description of the limit of sensitivity and rate of information of photoconductive devices. The second and third parts deal with the optical and electronic elementary processes occurring in photoconductors. Whereas the optical part is mostly concerned with special problems, the electronic part begins with a comprehensive treatment of the basic photoconductivity equation by S. Rittner. The fourth part is devoted to the various photoconductive materials and their properties and the fifth treats special processes and effects.

On reading this book, it becomes quite obvious that photoconductivity has almost developed into a science in itself; thus one finds that many subjects are treated in a very detailed way while others are only treated as a side line or not mentioned at all. One finds, for example, only very short mention of the Zinc Cadmium sulfides as photoconductors, although they certainly belong to one of the outstanding groups of available photoconductors. The original classic material in photoconductivity, selenium, is not mentioned even once. These are natural drawbacks in this type of book, but they are minor considering the tremendous amount of information the book makes available which otherwise could be gathered only from many dispersed sources.—H. KALLMANN, *Professor of Physics, New York University, New York, N. Y.*

### Thumbnail Review

**Transistor Manual.** General Electric Co., Semiconductor Products, 1224 W. Genesee St., Syracuse, N. Y., 61 p., \$50. Basic transistor theory, construction techniques and principles of circuit design for technicians,



hobbyists and experimenters. Specifications are given for all transistors registered with RETMA as of Dec. 1956.

**Numerical Integration of Differential Equations.** By A. A. Bennett, Wm. E. Milne, and H. Bateman, Dover Publications, Inc., 1956, 108 p, \$1.35. Treatment of several new methods of numerically solving differential equations. Methods dealing with the integration of ordinary differential equations involve interpolation procedures by use of polynomials, successive approximations and step-by-step methods of integration.

**Currents, Fields and Particles.** By Francis Bitter, John Wiley and Sons, Inc., New York, 1956, 599 p, \$8.50. A second year textbook in physics based on atomic physics. Contents include basic electromagnetic field theory, electromagnetic radiation, physical optics, wave mechanics and nuclear physics.

**Arcs in Inert Atmospheres and Vacuum.** Edited by W. E. Kuhn, John Wiley & Sons, Inc., New York, 1956, 188 p, \$7.50. Papers presented at symposium on "The Electric Arc in Inert Atmospheres and Vacuum" held at spring meeting of Electrochemical Society, Inc., in San Francisco.

**Printed Circuit Bibliography.** Television Society of Great Britain, London, 1956, 79 p. Compilation of published and some unpublished articles on printed circuits and allied techniques.

**Arithmetic Operations in Digital Computers.** By R. K. Richards, Van Nostrand Co., Inc., Princeton, N. J., 1955, 397 p, \$8.00. Introduction to mathematics necessary to understand digital computers including: Boolean Algebra, binary and decimal adding, subtracting, multiplying; decimal-to-binary and binary-to-decimal conversion.

**British Broadcasting: Radio and Television in the United Kingdom.** By Burton Paulu, University of Minnesota Press, Minneapolis, 1956, 457 p, \$6.00. Description and appraisal of nontechnical aspects of British broadcasting.

**English-Russian, Russian-English Electronics Dictionary.** Dpt. of the Army Technical Manual TM30-545. Superintendent of Documents, Government Printing Office, Washington, D. C., 1956, 944 p, \$3.50. Collection of about 22,000 Russian terms and abbreviations used in electronics and telecommunications. In addition to sources published in the U. S., U.S.S.R. and U.K., terms obtained from Soviet factories, research institutions and individual scientists are included.

**Dictionnaire francais-anglais des termes relatifs à l'électrotechnique et à l'électronique.** By H. Piraux, Editions Eyrolles, 61 Boulevard Saint-Germain, Paris, France, 1956, 168 p,



he's working  
for you

**THIS FELLOW IS TRAINED IN YOUR BUSINESS.** His main duty is to travel the country — and world — penetrating the plants, laboratories and management councils . . . reporting back to you every significant innovation in technology, selling tactics, management strategy. He functions as your all-seeing, all-hearing, all-reporting business communications system.

**THE MAN WE MEAN IS A COMPOSITE** of the editorial staff of this magazine. For, obviously, no one individual could ever accomplish such a vast business news job. It's the result of many qualified men of diversified and specialized talents.

**AND, THERE'S ANOTHER SIDE TO THIS "COMPOSITE MAN,"** another complete news service which complements the editorial section of this magazine — the advertising pages. It's been said that in a business publication the editorial pages tell "how they do it" — "they" being all the industry's front line of innovators and improvers — and the advertising pages tell "with what." Each issue unfolds an industrial exposition before you — giving a ready panorama of up-to-date tools, materials, equipment.

**SUCH A "MAN" IS ON YOUR PAYROLL.** Be sure to "listen" regularly and carefully to the practical business information he gathers.



**McGRAW-HILL PUBLICATIONS**

the specs are the proof . . .  
**the BEST BUYS are EICO®**  
 for COLOR & Monochrome TV servicing



**NEW COLOR**  
 and Monochrome  
 DC to 5 MC LAB & TV  
 5" OSCILLOSCOPE

#460  
 Factory-wired  
 and tested \$129<sup>50</sup>  
 Also available as kit \$79<sup>95</sup>

• Features DC Amplifiers!

Flat from DC-4.5 mc, usable to 10 mc.  
**VERT. AMPL.:** sens. 25 rms mv/in; input Z 3  
 megs; direct-coupled & push-pull thruout;  
 K-follower coupling bet. stages; 4-step freq-  
 compensated attenuator up to 1000:1.  
**SWEEP:** perfectly linear 10 cps-100 kc (ext.  
 cap. for range to 1 cps); pre-set TV V & H  
 positions auto, sync. ampl. & lim. **PLUS:**  
 direct or cap. coupling; bal. or unbal. inputs;  
 edge-lit engraved lucite graph screen; dim-  
 mer; filter; bezel fits std. photo equip. High  
 intensity trace CRT. 0.06 usec rise time. Push-  
 pull hor. ampl., flat to 400 kc, sens. 0.6 rms  
 mv/in. Built-in volt. calib. Z-axis mod. Saw-  
 tooth & 60 cps outputs. Astig. control. Re-  
 trace blanking. Phasing control.



**NEW TV-FM**  
**SWEEP GENERATOR**  
**& MARKER**

#368  
 Factory-wired  
 and tested \$119<sup>95</sup>  
 Also available \$69<sup>95</sup>  
 as kit

Entirely electronic sweep circuit (no mech-  
 anical devices) with accurately-biased in-  
 creduitor for excellent linearity. **Extremely**  
 flat RF output; new **AGC circuit** automati-  
 cally adjusts osc. for max. output on each band  
 with min. ampl. variations. **Exceptional tun-**  
**ing accuracy**; edge-lit hairlines eliminate  
 parallax. Swept Osc. Range 3-216 mc in 5  
 fund. bands. Variable Marker Range 2-75 mc  
 in 3 fund. bands; 60-225 mc on harmonic  
 band. 4.5 mc Xtal Marker Osc., xtal supplied.  
 Ext. Marker provision. Sweep Width 0-3 mc  
 lowest max. deviation to 0-30 mc highest max.  
 dev. 2-way blanking. Narrow range phasing.  
 Attenuators: Marker Size, RF Fine, RF Coarse  
 (4-step decade). Cables: output, 'scope horiz.,  
 scope vertical.

**NEW DYNAMIC**  
**CONDUCTANCE**  
**Tube &**  
**Transistor Tester**

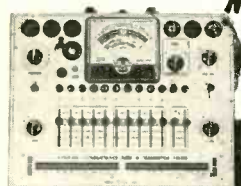

#666  
 Factory-wired  
 and tested \$109<sup>95</sup>  
 Also available \$69<sup>95</sup>  
 as kit

COMPLETE with steel cover and handle.

**SPEED, ease, unexcelled accuracy & thor-**  
**oughness. Tests all receiving tubes** (and  
 picture tubes with adapter). **Composite indi-**  
**cation of Gm, Gp & peak emission. Simulta-**  
**neous sel of any 1 of 4 combinations of 3 plate**  
**voltages, 3 screen voltages, 3 ranges of con-**  
**tinuously variable grid voltage** (with 5% ac-  
 curate pot). **New series-string voltages:** for  
 600, 450, 300 ma types. **Sensitive 200 ua**  
**meter. 5 ranges meter sensitivity** (1% shunts  
 & 5% pot.) **10 SIX-position lever switches:**  
 free point connection of each tube pin. **10**  
**push-buttons rapid insert of any tube element**  
**in leakage test circuit & speedy sel. of**  
**individual sections of multi-section tubes in**  
**merit tests. Direct-reading of inter-element**  
**leakage in ohms. New gear-driven rollchart.**  
**Checks n-p-n & p-n-p transistors; separate**  
**meter readings of collector leakage current &**  
**Beta using internal dc power supply. CRA**  
**Adapter \$4.50**

See the 50 EICO models IN  
 STOCK at your neighbor-  
 hood distributor. Write for  
 FREE Catalog E-8

Prices 5%  
 higher on  
 West Coast

**EICO® 33-00 NORTHERN BLVD.,**  
**LONG ISLAND CITY 1, N. Y.**

Circle 289 Readers Service Card

NEW BOOKS

(continued)

960 fr. English equivalent of ap-  
 proximately 10,000 French technical  
 terms related to electronics and as-  
 sociated fields.

**Dictionnaire anglais-français des**  
**termes relatifs à l'électrotechnique et**  
**à l'électronique.** By H. Piraux, Edi-  
 tions Eyrolles, Paris, France, 1956,  
 296 p, 1,850 fr. English-French com-  
 panion volume to French-English dic-  
 tionary listed above. Included in this  
 volume are conversion tables for units  
 of length, volume, weight, photometry,  
 colorimetry, etc.

**Electricity and Magnetism.** By J.  
 Newton, Philosophical Library, New  
 York, 1957, 613 p, \$10.00. Introduc-  
 tory text for engineering students  
 thoroughly covers basic material.  
 This British text includes material not  
 usually found in American texts on  
 the same level.

**Auto Radio Service Manual, Vol. 6.**  
 Howard W. Sams & Co., Inc., India-  
 napolis, Indiana, 1957, 240 p, \$3.95.  
 Servicing information on 45 auto-radio  
 chassis produced during 1956 and late  
 1955.

**Essential Characteristics.** Electronic  
 Components Division, General Elec-  
 tric, Schenectady, N. Y., 1957, 228 p,  
 \$.75. Seventh edition of tube handbook  
 has data on 1,593 tube types. New  
 material includes plate dissipation  
 ratings and page of basic data on  
 loudspeaker enclosure dimensions.

**Auto Radio Removal—1955.** Howard  
 W. Sams & Co., Inc., Indianapolis,  
 1957, 104 p, \$2.95. Initial manual of  
 series covers instructions for removal  
 of radios, power-supply units and  
 loudspeakers from 1955 automobiles.

**Automation: Its Purpose & Future.**  
 By Magnus Pyke, Philosophical Li-  
 brary, New York, 1957, 191 p, \$10.00.  
 Nontechnical discussion of application  
 of electronic computers in mass-pro-  
 duction industries and business. Fac-  
 tors are considered which will effect  
 the rapidity of spread of automatic  
 control in different countries.

**Analysis of Bistable Multivibrator**  
**Operation: The Eccles Jordan Flip-**  
**Flop Circuit.** By P. A. Neetson,  
 Philip's Technical Library, Eindhoven,  
 Holland, 1956, 82 p, \$2.15. A detailed  
 analysis of the transient behavior of  
 a bistable multivibrator with many  
 simplifying assumptions that was the  
 author's doctoral dissertation at the  
 Technical University of Delft, Hol-  
 land.

**Metallic Rectifiers — Principles and**  
**Applications.** By Leonard R. Crow,  
 Howard W. Sams & Co., Inc., Indian-  
 apolis, 1957, 280 p. \$3.00 (paper).  
 Copper-oxide, selenium, magnesium-  
 oxide and silicon rectifiers are covered  
 with respect to characteristics and cir-  
 cuit applications. A glossary of  
 electrical and metallic rectifier termi-  
 nology, a list of sources and a classi-  
 fied bibliography are included as ap-  
 pendices.

**Pinpoint TV Troubles in 10 Minutes.**  
 By Coyne Electrical Schools, Howard  
 W. Sams & Co., Inc., Indianapolis,  
 1957, 310 p, \$3.00 (paper). A prac-

**ELECTRONIC &**  
**COMMUNICATIONS**  
**ENGINEERS**

**pioneer**  
**with page**

**WORLD LEADER**

**IN SCATTER**

**COMMUNICATIONS**

As pioneers in scatter and other  
 advanced types of radio communi-  
 cations systems PAGE has earned  
 an international reputation. Mem-  
 bers of our organization work  
 closely with representatives of  
 the U. S. and foreign governments  
 and industries in the development  
 of multimillion-dollar tele-com-  
 munications networks. Challeng-  
 ing assignments take our engi-  
 neers to many corners of the  
 globe.

Due to the increased demand for  
 PAGE-designed, installed, tested  
 and operated systems, we now  
 offer a few high-salaried positions  
 in our Washington, D. C., office  
 as well as overseas (Europe,  
 Pacific, Near East). We require  
 engineers with a minimum of 3  
 years experience in installation,  
 adjustment and maintenance of  
 communication receivers and as-  
 sociated terminal equipment, as  
 well as engineers experienced in  
 high-powered transmitters, an-  
 tennas and transmission lines.

Engineers who locate in the  
 Washington, D. C., area find that  
 it offers outstanding educational,  
 cultural and recreational facili-  
 ties. As a center of Government-  
 sponsored engineering and  
 research laboratories, it is particu-  
 larly interesting to the engineer  
 desirous of pursuing advanced  
 studies.

New, attractive housing in all  
 price ranges is readily available  
 in the city's beautiful suburbs,  
 within easy reach of our main  
 offices in the heart of the capital.

We'll send you full information  
 upon receipt of your inquiry.

Write: J. P. Gaines, Director of  
 Personnel

**page**

**Communications Engineers, Inc.**

**710-B 14th St., N. W.**

**Washington 5, D. C.**





## All business is specialized

...and nothing specializes on your business like your business paper

Here's a smart business man. He spends his time where every sitzmark parks a prospect at his feet. It's simple sense: He *specializes* . . . and it *pays!*

Your business is specialized, too . . . and so is your business paper. The time you spend with it pays . . . for its editors are experts in your specialty. They scout the field . . . report what's good that's new . . . find ideas that worked . . . suggest methods to keep you a leap ahead of competition.

The ad pages are as specialized as the editing. They, too, tend strictly to business . . . your business. They bring you data on new products, new materials . . . gather in one place a raft of ideas on where-to-buy-what, or how to make (or save) a dollar.

That's help you can't find concentrated into such quick reading time *anywhere* else! It's help that puts many a man out front in his field, as a specialist who knows what's what today . . . sees what's coming tomorrow. It's simple sense to read every page, every issue.

This business paper in your hand has a plus for you, because it's a member of the Associated Business Publications. It's a paid circulation paper that must earn its readership by its quality . . . And it's one of a leadership group of business papers that work together to add new values, new usefulness, new ways to make the time you give to your business paper still more profitable time.

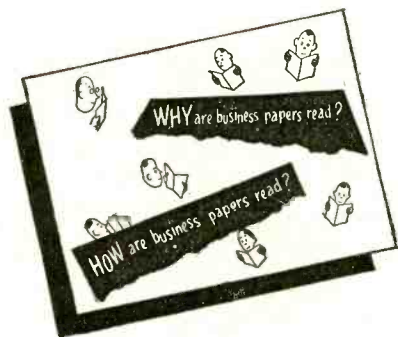

A copy of this quick-reading, 8-page booklet is yours for the asking. It contains many facts on the benefits derived from your business paper and tips on how to read more profitably. Write for the "WHY and HOW booklet." Room 2710.

**McGraw-Hill Publishing Company**  
330 West 42nd St., New York 36, N. Y.



One of a series of advertisements prepared by THE ASSOCIATED BUSINESS PUBLICATIONS

**IMMEDIATE DELIVERY**

(Small Quantity)

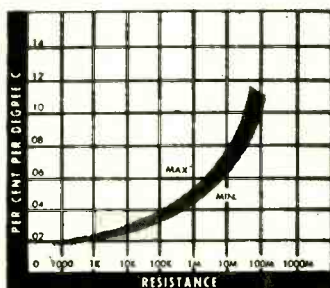
**P**RECISION **C**ARBON **D**EPOSITED **R**ESISTORS

Typical temperature coefficient characteristics

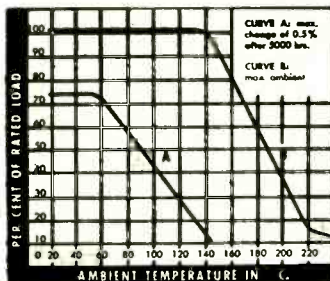

Typical derating curve for 1 watt

STANDARD RESISTORS  $\pm 1\%$  TOLERANCE IN 10% RMA  
VALUES FROM 10 OHMS TO 2.7 MEGOHMS

APST— $\frac{1}{2}$  WATT=SALES OFFICES & DISTRIBUTORS  
APXT— $\frac{1}{2}$  WATT AND APCT—1 WATT=DISTRIBUTORS

Factory Delivery: 4-5 Weeks  
1/10, 1/5, 1/4, 1/2, 1, 2 and 5 Watt

**ALLIES' PRODUCTS CORPORATION**  
P. O. Box 188, Kendall Branch, Miami, Florida

BROCHURE SUPPLIED UPON REQUEST.

Circle 301 Readers Service Card

**IF THIS IS YOUR PROBLEM**

If you need effective, highly readable, smartly illustrated company literature (booklets, pamphlets, manuals) to display your products, inform the public of your operations, attract key personnel to your plant, train employees, and perform any of the other communicative functions that are vital to your business . . .

**THIS IS YOUR ANSWER**

The McGraw-Hill TECHNICAL WRITING SERVICE has a staff of more than 150 highly-trained writers, editors, and illustration specialists whose job it is to create technical and general literature for industry. We write, illustrate, design, and print Equipment Manuals, Product Bulletins, Handbooks, Company Histories, Annual Reports, and other specialized material. Save money and time. Let our staff be your staff for Technical and Business publications.

*This service is available through ad agencies.*

Write • Phone

**TECHNICAL WRITING SERVICE**  
McGraw-Hill Book Co., Inc.  
330 W. 42nd St., N. Y. 36, N. Y.  
LOngaire 4-3000

tical, quick-answer, tv troubleshooting reference book for service technicians.

**Statistical Analysis of Stationary Time Series.** By U. Grenander and M. Rosenblatt, John Wiley & Sons, Inc, 1957, 300 p, \$11.00. A rigorous treatment of the theory of stationary time series that unifies the methods of analysis and presents them on a level suitable for statisticians and physicists.

**Scatter Propagation Theory and Practice.** By Ira Kamen and George Doundoulakis, Howard W. Sams & Company, Inc., Indianapolis, 1956, 196 p, \$3.00. With a minimum of math, this book attempts to familiarize technicians and engineers with the principles and practices involved in installing, operating and maintaining scatter systems. Both ionospheric and tropospheric forms of propagation are discussed and many examples of existing equipment including that in the northern DEW line and other scatter lines are given.

**Audio Amplifiers and Associated Equipment (Vol. 8).** Howard W. Sams & Co., Inc., Indianapolis, 1957, 226 p, \$3.95. This volume covers late 1955 and early 1956 models of audio amplifiers, preamplifiers and a-m f-m custom tuners and is intended for service technicians, audio engineers and experimenters.

**Frequency-Modulated Radio.** By K. R. Sturley, The Macmillan Co., New York, 1957, 120 p, \$3.00. General introduction to principles, theory, design, construction and servicing of f-m equipment for the engineering student, amateur and service technician.

**Low-Power Telecasting—A Handbook for Station Owners and Operators.** By Harold E. Enne, Howard W. Sams, Inc., Indianapolis, 1957, 106 p, \$2.95 (paper). Survey of basic considerations in planning low-power installation. Antennas, propagation, transmitters and vidicon camera chains, both live and film, are also covered.

**Symposium on Minimum Property Values of Electrical Insulating Materials.** American Society for Testing Materials, 1916 Race St., Philadelphia, 1957, 48 p, \$1. Collection of seven papers presented at Feb. 14, 1956 meeting of committee D-9.

**Supervision of Scientific and Engineering Personnel.** Compiled by John T. Lloyd and Robert D. Gray, Industrial Relations Section, California Institute of Technology, Pasadena, Calif., 1956, 82 p, \$8.75. Outline of results of series of conferences and meetings on characteristics and development of professional employees, building and maintaining a good technical team, appraisal of performance, supervisors role in professional development, salary administration policies, benefit plans, complaint and grievance handling, unionization of professional employees, communications, professional work group organization, and what professional workers expect of their supervisors.





## How to keep informed on the “with what” part of your business

AT YOUR FINGER TIPS, issue after issue, is one of your richest veins of job information – advertising. You might call it the “with what” type – which dovetails the “how” of the editorial pages. Easy to read, talking your language, geared specifically to the betterment of your business, this is the kind of practical data which may well help you do a job quicker, better – save your company money.

Each advertiser is obviously doing his level best to give you helpful information. By showing, through the advertising pages, how his product or service can benefit *you* and *your* company, he is taking *his* most efficient way toward a sale.

Add up all the advertisers and you’ve got a gold mine of current, on-the-job information. Yours for the reading are a wealth of data and facts on the very latest in products, services, tools . . . product developments, materials, processes, methods.

You, too, have a big stake in the advertising pages. Read them regularly, carefully to keep job-informed on the “with what” part of your business.



**McGraw-Hill PUBLICATIONS**

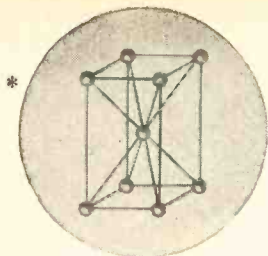

+



\*PURE TIN plated on Somers Thin Strip.

Somers engineers have developed a special hot tin plate process which now will provide the smooth surface, solderability, adherence and complete absence of slag so essential to manufacturers of:

## PRINTED CIRCUITS CAPACITORS CABLE WRAPPING

Tin coatings of .00002 to .00008 and .0002 to .0003 are available on brass, copper, bronze and other Thin Strip metals in gauges from .012 down to .002, widths from 1/8" to 6" and wider.

And, of course, Somers exacting standards for tolerance, tensile strength and other physical properties are rigidly maintained,

Whatever your requirements for tin plated thin strip, you can depend on Somers long experience and modern equipment for a quality product.

Write for further information and confidential data blank. Somers will gladly analyze your problem without obligation.



**Somers Brass Company, Inc.,**  
112 BALDWIN AVE., WATERBURY, CONN.

Circle 231 Readers Service Card

## Backtalk

### Ultrasonic Control

DEAR SIRs:

I WAS happy to see the article on our Space Command (Ultrasonic Gong Controls TV Sets, p. 156, March 1957) and I have heard some favorable comments about the way you set it up optically, the use of photographs and the general readability.

But there never seem to be any roses without thorns. The caption under Fig. 4 is correct in its first sentence, but the second sentence is a lost sheep which has strayed from Fig. 3.

The caption for Fig. 2 should read as follows:

Single-tune button steps tuner switch in one direction, a skip-stop mechanism provides stopping only on desired channels.

ROBERT ADLER

Research Department  
Zenith Radio Corporation  
Chicago, Illinois

### Visual, Not VHF

DEAR SIRs:

A NUMBER of times I have noticed an error in *ELECTRONICS* magazine and thought you might not mind being corrected on it.

In the air navigational system commonly called VOR, the letters VOR stand for visual omnidirectional range, rather than for vhf omnidirectional range. Reference: Air Force technical orders and other documents covering the system.

CLAUD N. AUSTIN  
Austin Motivator Laboratories  
Seattle, Washington

### 3-D Printed Wiring

DEAR SIRs:

WE HAVE received several letters (from as far away as London) from manufacturers interested in the application of techniques described in the article, "Three-Dimensional Printed Wiring," which appeared in your June issue, page 160.

The research reported was supported jointly by the Army, Navy, and Air Force under contract with the Massachusetts Institute of Technology.

F. P. HAZEL

Lincoln Laboratory  
Massachusetts Institute of Technology  
Lexington, Massachusetts

## mercury vapor detector

tells instantly when a hazard exists  
in plant or lab atmospheres

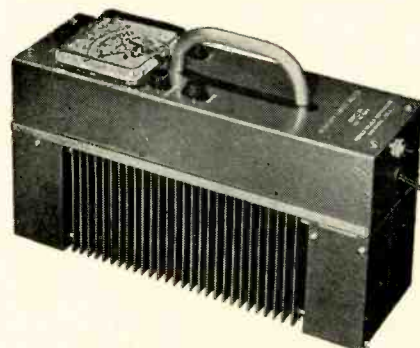

Meter is calibrated in mercury concentrations for quick indication. The toxic limit is a full-scale reading on the high sensitivity scale of Model 23, illustrated. Wt.: 7 lbs.; size 13" x 8 1/2" x 4 1/2". Three models for varying ranges.

Write for bibliography on the mercury vapor hazard, and literature on Kruger Mercury Vapor Meters.

**HAROLD KRUGER**  
**INSTRUMENTS**

BOX 164 • SAN GABRIEL, CALIF.

Circle 232 Readers Service Card

For consistently high purity...

**"LINDE" M.S.C. RARE GASES**  
Trade-Mark  
(Mass Spectrometer Controlled)

- Helium
- Argon
- Neon
- Krypton
- Xenon

In radar electronic equipment, nuclear radiation counters, cosmic ray cloud chambers, and thyratrons, where the purest rare gases are demanded, LINDE M.S.C. Grade gases meet the specifications. They are produced under continuous mass spectrometer control to assure you of gases of known purity and consistently high quality. LINDE, the world's largest producer of gases from the atmosphere, can meet your individual needs of volume, mixture, and container.

For information on the physical, chemical, and electrical properties of these gases, send for the booklet, "LINDE Rare Gases."



### LINDE COMPANY

Division of  
Union Carbide Corporation  
30 E. 42nd Street **ucc** New York 17, N.Y.

In Canada:  
LINDE COMPANY, Division of Union Carbide  
Canada Limited, Toronto

The term "Linde" is a registered trade-mark of Union Carbide Corporation.

Circle 233 Readers Service Card

August 1, 1957 — *ELECTRONICS*



# PROFESSIONAL SERVICES

## The BOSTICK LABORATORY, INC.

Pulse Transformers—Inductors  
Complete Service—Consulting,  
Design, Development;  
Also Production Orders  
Main Plant  
Tynnesboro,  
Mass. Business Office  
P. O. Box 167  
Chester, N. J.

## ERCO RADIO LABORATORIES, INC.

*Radio Communications Equipment*  
Engineering - Design - Development - Production  
Our 27th Year in Air to Ground  
Communications and Radio Beacons  
Garden City • Long Island • New York

## ALBERT PREISMAN

*Consulting Engineer*  
Television, Pulse Techniques, Video  
Amplifiers, Patent technical consultation.  
616 St. Andrews Lane, Silver Spring, Maryland

## BRIGGS ASSOCIATES, INC.

*Engineering Services*  
ELECTRONICS MECHANICAL  
Development — Manufacturing — Consulting  
Special Machines — Instrumentation — Automation  
Electron Tube Design, Materials, Reliability  
10 DeKalb St. Broadway 9-2120 Norristown, Pa.

## McCann Engineering Company

*Consulting Mechanical Engineer*  
Design and Development of Test Equipment  
for Synchros, Potentiometers, Gyros, Etc.  
Redesign of Products—Trouble Shooting  
Production—Automatic Machinery.  
Special Machines with Sequence, Form  
Recognition, Dimension Decision and  
Special Environment Features.  
9210 So. Vermont Los Angeles 44, Calif.

## TELECHROME MFG. CORP.

*Electronic Design Specialists*  
COLOR TELEVISION EQUIPMENT  
Flying Spot Scanners, Color Synthesizers, Keyers,  
Monitors, Oscilloscopes and Related Apparatus,  
Telemetering for Guided Missiles.  
J. R. Popkin-Churman, Pres. & Div. of Eng.  
28 Ranick Dr. Amityville, L. I., N. Y.

## CROSBY LABORATORIES, INC.

*Murray G. Crosby & Staff*  
Radio - Electronics  
Research Development & Manufacturing  
Communications, FM & TV  
Robbins Lane, Hicksville, N. Y.  
WEliS 1-3191

## Measurements Corporation

*Research & Manufacturing Engineers*  
HARRY W. HOUCK MARTIAL A. HONNELL  
Specialists in the Design and  
Development of Electronic Test Instruments  
Boonton, New Jersey

## WHEELER LABORATORIES, INC.

Radio and Electronics  
Consulting — Research — Development  
R-F Circuits — Lines — Antennas  
Microwave Components — Test Equipment  
Harold A. Wheeler and Engineering Staff  
Great Neck, N. Y. HUnter 2-7876

## DELAWARE PRODUCTS CO.

Analog Voltage to Digital Conversion  
Digital Voltage Recording Systems  
*Design-Development-Manufacturing*  
300 Broadway Camden 3, N. J.

## NIAGARA ELECTRON LABORATORIES

CONSULTATION - DESIGN - CONSTRUCTION  
MFG. THE THERMOCAP RELAY  
Specializing in solution of problems of electronic  
and electro-physical instrumentation for the re-  
search or analytical laboratory. Industrial plant  
problems also invited  
Andover, New York Cable Address: NITRONLAB

## YARDNEY LABORATORIES

*Research-Design-Development*  
Electro-Chemical Generators of Energy  
40-48 Leonard Street Worth 6-3100  
New York 13, N. Y.

## ELECTRONIC RESEARCH ASSOCIATES, INC.

"TRANSISTORIZE" YOUR PRODUCT!  
Complete Service in consulting, research, develop-  
ment, and production on Transistor circuitry,  
products and instrumentation.  
67 East Centre Street Nutley, N. J.  
NUTley 2-5410

## PICARD & BURNS, INC.

*Consulting Electronic Engineers*  
Analysis and Evaluation  
of Radio Systems  
Research Development and Production  
of Special Electronic Equipment  
240 Highland Ave. Needham 94, Mass.

# • CONTACTS •

## MANUFACTURERS' REPRESENTATIVES IN THE ELECTRONIC INDUSTRY

**HORMAN  
ASSOCIATES, INC.**  
2017 "S" STREET, N.W.  
WASHINGTON 9, D. C.  
DECATUR 2-5705

SERVING  
DELAWARE, MARYLAND,  
DISTRICT OF COLUMBIA,  
ARLINGTON AND FAIRFAX  
COUNTIES IN VIRGINIA

TELETYPE NO. WA-559

### REPRESENTING —

HEWETT-PACKARD CO.  
SORENSEN & COMPANY INC.  
VARIAN ASSOCIATES  
BETA ELECTRIC CORP.  
ELECTRO-MEASUREMENTS INC.  
GERTSCH PRODUCTS INC.

SENSITIVE RESEARCH INST. CORP.  
SANBORN COMPANY  
KINTEL (formerly KAY LAB)  
JOHN FLUKE MANUFACTURING CO.  
BUDD STANLEY COMPANY, INC.  
WEINSCHEL ENGINEERING CO.

Complete Recalibration Laboratory

## SAMUEL K. MACDONALD, INC.

manufacturers representatives over 25 years  
1531 SPRUCE STREET, PHILA. 2, PA.

Territory: Pennsylvania • New Jersey  
Delaware • Maryland  
Virginia • West Virginia  
District of Columbia  
Other Offices:  
Pittsburgh  
Baltimore  
Washington, D.C.

## 160,000 prospects!

In *Electronics* magazine the advertiser talks  
to 46,000 paid subscribers, plus 3 or 4  
interested potential customers receiving each  
copy for pass-along reading . . . approxi-  
mately 160,000 prospects



**RHEOSTATS  
RESISTORS**

**TOROIDAL  
CORE  
WINDING  
MACHINES**

**REX RHEOSTAT CO.**  
BALDWIN, N. Y.

## CRCA SERIES "200" RESISTORS

.01% accurate, .003% stable. 5 ppm/°C  
Temp. Coeff. Epoxy Encapsulated to MIL  
specs. Hundreds of sizes, terminal types.  
48 hrs. special delivery service.

CONSOLIDATED RESISTANCE  
COMPANY OF AMERICA, INC.  
44 Prospect St., Yonkers, N. Y.

## IDENTIFICATION NAME PLATES

For controls and panels—precision engraved on  
bakelite or black anodized alum.—any titles—  
quick service by mail on large or small jobs—send  
for sample and prices.

ATLANTIC ENGRAVERS, INC.  
52 Ocean Ave. Amityville, N. Y.



# TO THE **ONE MAN IN THREE**

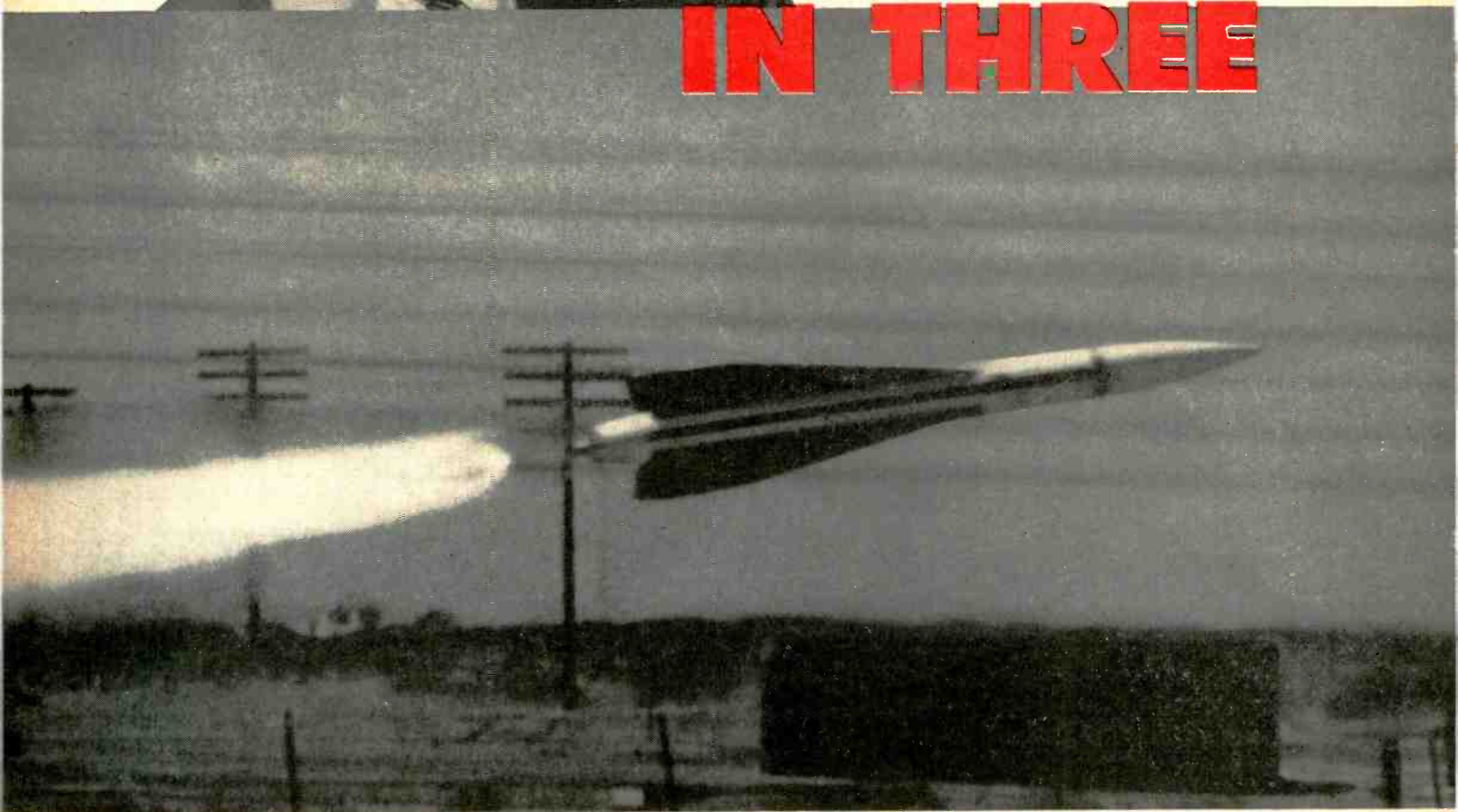

OFFICIAL U. S. ARMY PHOTOGRAPH

**ARMY'S HAWK MISSILE**, recently revealed, destroys attackers flying at even the lowest altitudes and in the blind zone of conventional radars. Raytheon is prime contractor with complete systems responsibility for HAWK—and for the Navy's new air-to-air Sparrow III.

To the one man in three who will qualify as a Raytheon engineer:

our small, versatile project groups are staffed with extremely capable engineers. This policy pays off exceedingly well for energetic, imaginative men who are looking for individual recognition with the challenge of responsibility and ready opportunity for advancement.

PLAN TO VISIT RAYTHEON DURING YOUR NEW ENGLAND VACATION — Contact Ed Herlin at above address or telephone TWinbrook 4-7735.



Which of these interesting Situations with a Future is right for you?

As one of the world's fastest growing electronics companies with a record for history-making achievements, Raytheon is continually expanding. Interesting, rewarding openings for all types of engineers now exist in:

**COMMUNICATIONS (Commercial and Military)**—scatter, microwave relay, multiplex, mobile transistorized equipment.

**COUNTERMEASURES**—radar countermeasures equipment, advanced study projects.

**RADAR (Pulse and CW Systems)**—search, fire control, bombing, navigation, air traffic control, weather and commercial marine.

**MARINE EQUIPMENT**—submarine, ship, and airborne sonar, depth sounders, direction finders.

**GUIDED MISSILES**—prime contracts: Navy Sparrow III (air-to-air), Army Hawk (ground-to-air).

**MICROWAVE TUBES**—amplitrons, magnetrons, klystrons, traveling wave tubes, storage tubes.

**ELECTRON TUBES, SEMICONDUCTOR DEVICES, MAGNETIC COMPONENTS • MICROWAVE COOKING OVENS, ELECTRONIC INDUSTRIAL EQUIPMENT, ELECTRONIC MEDICAL EQUIPMENT**

Raytheon plants are ideally situated for delightful suburban living in New England, California and Tennessee.

*See us during the Wescon Show.* Members of our engineering staff will be available for interviews during the Wescon Show. Get in touch with us in San Francisco.

If you can't see us at Wescon, contact us for full information, including helpful answers to your questions. Please write to E. H. Herlin at the address below.

**RAYTHEON MANUFACTURING COMPANY**  
WALTHAM 54, MASSACHUSETTS

Are you the  
**ONE MAN IN THREE?**

Excellence  
in Electronics



**MICROWAVE & POWER TUBE** engineers check operation of Raytheon microwave tubes in Air Force jet.



**WAYLAND LABORATORY** engineers developed this 40-foot L-band antenna to extend the range of radar.



**MAYNARD LABORATORY** engineers design and flight test airborne navigational and guidance systems.



**MISSILE SYSTEMS DIVISION** facilities include observation tower with radar tracking equipment.

**ENGINEERS:** *Electronic & Mechanical, PHYSICISTS*

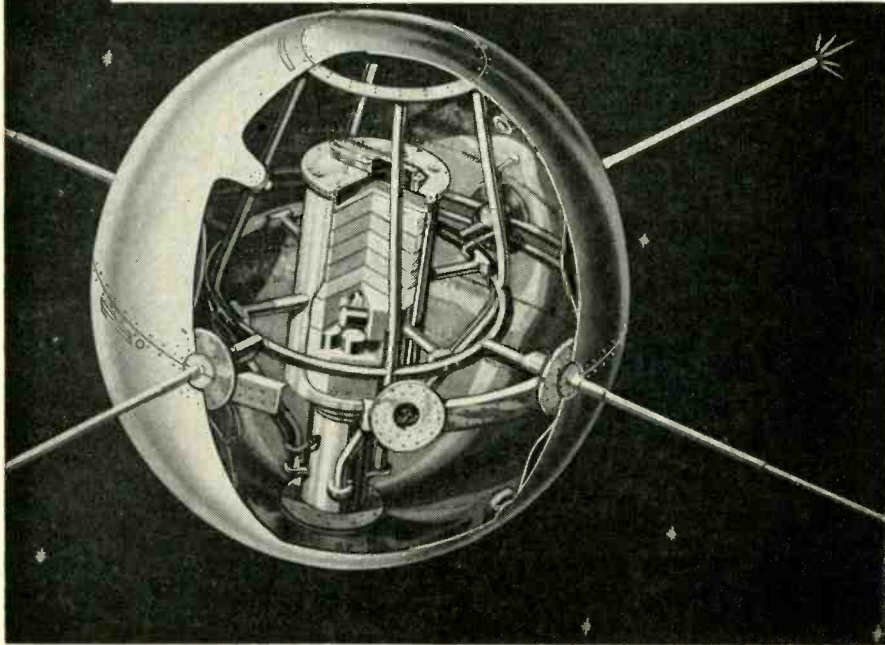

Melpar's work on the earth satellite is one of many diversified projects.

**Melpar's more than 90 projects give wider scope to men of talent**

At Melpar the problems posed by our more than 90 current projects allow you to work in the area of your choice and make contributions on advanced levels.

Our dynamic growth (we've doubled in size every 24 months for the past 11 years) constantly creates new middle and top level openings; our policy of *individual recognition* allows you to compete for them *strictly* on merit, and to receive financial compensation limited only by your ability.

As a member of a Melpar project group you'll enjoy freedom and a team spirit found only in a young organization of our size. Each project group is charged with responsibility for solving problems from conception to prototype. This means that you gain invaluable experience in inter-related spheres, essential to eventual directorship responsibility.

Living is relaxed and good in the Washington, D. C. area with its mellow climate and spacious suburbs. Our new air-conditioned laboratory is well-instrumented with an eye to future needs and is situated on a wooded 44-acre tract.

**DUE TO OUR DIVERSIFICATION, OPENINGS EXIST IN PRACTICALLY EVERY PHASE OF ELECTRONIC RESEARCH & DEVELOPMENT**

Qualified engineers will be invited to visit Melpar at company expense:

For detailed information on openings, the laboratory, and the industry-free area in which we're located, write:



Technical Personnel Representative

**MELPAR** *Incorporated*  
 A Subsidiary of Westinghouse Air Brake Company  
 3253 Arlington Boulevard  
 Falls Church, Virginia

**Engineers:**  
*What's your solution of effective handling of 50 complex projects simultaneously?*

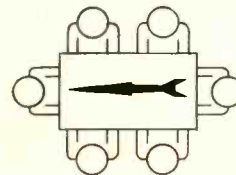

**SEE HOW ARMA'S PROJECT TEAM SYSTEM BENEFITS THE INDIVIDUAL ENGINEER AND THE COMPANY**

Science and technology are becoming increasingly complex. So also are the solutions to the advanced engineering problems which ARMA is called upon to resolve, such as developmental aspects of the Inertial Guidance System for ICBM Titan and the Fire Control System for B-52 tail defense.

To make sure that each project receives expert guidance at every phase—research, design, development—ARMA entrusts each engineering contract to a group of engineers known as a "Project Team."

Composed of key personnel drawn from the major departments of the Engineering Division, a Project Team must see its project through, from conception to completion. Each engineer represents his department and carries equal responsibility for the success of the operation.

*To the Individual Engineer*, the value of the system is immeasurable. He gains an overall view of company operations, diversifies his professional knowledge and acquires a specialist's know-how in his field.

*If Professional Engineering of this Calibre* is what you are looking for—and you have had 2 to 5 years experience in precision instrumentation or electronic devices and systems or inertial navigation systems—we will welcome your inquiries at ARMA.

Current openings are at all levels and in various phases of design, development, analysis, evaluation and test operations.

Please forward your confidential resume to Robert Burchell. No reference contact without your permission. Our reply will include two brochures with detailed information about ARMA and its location on suburban Long Island.

Technical Personnel Dept. E-674

**ARMA**  
**DIVISION OF AMERICAN BOSCH ARMA CORPORATION**  
 Roosevelt Field, Garden City, Long Island, N. Y.



TI  
**ENGINEERS,  
 PHYSICISTS**

**BUILD**



## TRANSISTOR 'STOP-WATCHES' FOR INDUSTRY\*

*accuracies to a 50 millionth | intervals from microseconds to months*

Experienced graduate engineers and physicists are invited to join one of the many expanding programs at engineer-managed Texas Instruments... where recognition of individual achievement has contributed to TI's fifteenfold growth in the last ten years — to a current \$45 million volume. Advanced personnel policies include company-sponsored educational assistance, profit sharing, insurance, and retirement programs.

Texas Instruments plants are within Dallas, yet away from downtown traffic... within 5 minutes of fine residential areas, churches, and public and private schools. Your home will be within 15 minutes of year-around recreational, amusement and cultural activities.

**SEMICONDUCTORS & OTHER COMPONENTS** — Transistors, transistor circuits, diodes, rectifiers, transformers, resistors, panel meters, test equipment. *Write W. C. Spaller.*

**ELECTRONIC & ELECTROMECHANICAL APPARATUS** — Radar, sonar, infrared, navigation, magnetics, telemetering, communications, computers. *Write R. E. Houston.*

**RESEARCH** — PhD level for research: semiconductor materials and devices, ferromagnetics, infrared, high speed data reduction, etc. **ADMINISTRATION** — Engineers for: production, planning, purchasing, cost analysis, etc. *Write W. D. Coursey.*

\* Texas Instruments engineers are building portable electronic timing devices to uncanny accuracies with interval variations to infinity. They allow applications never before practical because of previous size, weight, power drain, and maintenance limitations... particularly in airborne installations. Essentially binary counting and storage devices, these TI timers present an entirely new concept in time measurement... a result of the new design freedom allowed by transistors... of which TI is also the world's largest commercial manufacturer.



**TEXAS INSTRUMENTS**  
 INCORPORATED

6000 LEMMON AVENUE DALLAS 9, TEXAS

ENGINEERS & PHYSICISTS *Electronics*

Information manual  
about APL and its  
current programs  
now available

The Applied Physics Laboratory (APL) of The Johns Hopkins University is unique in that we are neither an industrial nor an academic organization, but rather a composite, having drawn freely from the methodologies of each.

For thirteen years APL has pioneered in guided missiles. Today we are engaged in a broad program of R & D for the Navy; in addition, we are responsible for technical direction of industrial and academic contractors in developing the Terrier, Talos and other major weapons and weapons systems. Our staff members enjoy not only the stimulus of association with their immediate colleagues at APL, but also with those in other organizations of considerable stature.

NEW 30-PAGE PUBLICATION

A few positions for senior engineers and scientists are now open. Information on our accomplishments and goals is available in a new 30-page publication, just off the press.

In it staff leaders representing each of the various disciplines and fields outline the nature of their programs. Information on our new laboratory in Howard County, Md. (equidistant between Baltimore and Washington) is also included, together with facts on the outstanding communities in which our staff members live.

*Quantity is somewhat limited. May we suggest you send now to:  
Professional Staff Appointments.*

The Johns Hopkins University  
Applied Physics Laboratory

8609 Georgia Avenue

Silver Spring, Md.

**ENGINEERS**

**PARTS APPLICATION  
(Reliability)**

ME or EE degree with design experience and/or application experience. Job will be to recommend types of parts to be used and how these parts shall be used.

Qualified men will become a vital part of a Reliability Group.

**GM  
INERTIAL GUIDANCE  
SYSTEM PROGRAM**

**• ELECTRONICS DIV.,  
Milwaukee 2, Wis.  
Flint 2, Mich.**

Enjoy Challenging Opportunities in the most versatile Laboratories in the country. Work with the top men in the field and with the finest test, research and development facilities. We are in the process of a Major, Permanent, Expansion Program. New Plant facilities being added in suburban Milwaukee area.

To aid you in your professional advancement AC will provide financial assistance toward your Master's degree. A Graduate Program is available evenings at the University of Wisconsin, Milwaukee.

GM's Electronics Division aggressive position in the field of manufacture and GM's long-standing policy of decentralization creates individual opportunity and recognition for each Engineer hired.

**Recent EE,ME  
Graduate Inquiries  
Also Invited**

Milwaukee offers ideal family living in a progressive neighborly community in cool, southern Wisconsin where swimming, boating, big league baseball and every shopping and cultural advantage is yours for the taking.

To arrange personal, confidential interview in your locality send full facts about yourself today to

**Mr. Cecil E. Sundeen  
Supervisor of Technical Employment**

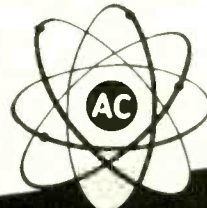

**Electronics Div.  
General Motors Corp.  
FLINT 2, MICHIGAN  
MILWAUKEE 2, WISCONSIN**





Project Engineer Robert J. Cantwell uses a system of gimbals to describe navigational problem in the analysis of a new system design.

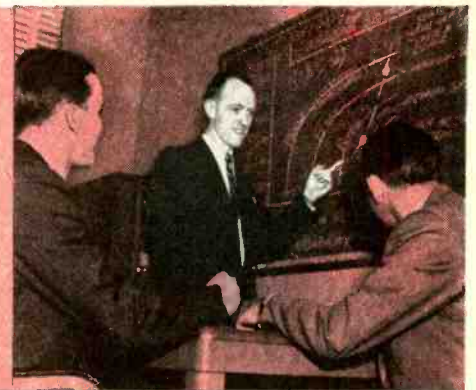

Development Engineer J. Robert Holmes computes, with other systems reliability analysts, the operational worth of a bombing system.

You'll find a  
new  
challenge  
**DEVELOPING**  
airborne  
computers  
at



Staff Engineer William Howard reviews gearing accuracy requirements of test equipment with electronic circuit designers.



Circuit Development Group Leader Ralph Wolcott considers future changes in computer output unit for bombing-navigational systems.

The design and development of BRANE (Bombing Radar Navigation Equipment), now being installed in B-52 aircraft, offer stimulating new challenges to creative engineers at IBM Owego.

Projects currently in process include: Inertial guidance . . . display equipment . . . radar data presentation . . . digital and analog systems . . . transistor circuit packaging . . . test equipment . . . installation.

If you are an electrical or mechanical engineer, a mathematician or a physicist — and want to do development work — you owe it to yourself to investigate the exciting possibilities that airborne computers offer you at IBM Owego.



Development Engineer John Walsh discusses the use of a recording storage tube at IBM's Airborne Computer Laboratories, Owego, N. Y.

**FOR DETAILS,**  
just write, outlining background and interests, to:  
Mr. R. A. Whitehorne, Dept. 408  
Mgr. of Engineering Recruitment  
International Business Machines Corp.  
590 Madison Ave., New York 22, N. Y.

- DATA PROCESSING
- ELECTRIC TYPEWRITERS
- MILITARY PRODUCTS
- SPECIAL ENGINEERING PRODUCTS
- SUPPLIES
- TIME EQUIPMENT



Plants and laboratories: Endicott, Kingston, Owego, Poughkeepsie, N. Y.; Lexington, Ky.; Rochester, Minn.; San Jose, Calif.



## BENDIX OFFERS THE FINEST GUIDED MISSILE OPPORTUNITIES IN THE MIDDLE WEST

It isn't often that you can combine ideal living conditions with outstanding advancement opportunities. At Bendix Guided Missiles we sincerely believe we can offer you both.

We are sure that you would enjoy living in an attractive community convenient to metropolitan centers and recreational areas.

And, we are equally confident that as prime contractor for the important and successful Talos Missile, no one can offer a greater variety of interesting and challenging job opportunities in the guided missile field.

If you would like proof of these strong

statements, why not fill out the coupon and send for a copy of our thirty-six-page booklet "Your Future in Guided Missiles". It not only gives a detailed story of guided missile operations, but it also presents interesting facts about living conditions in the area, the many special employee benefits, and the wide range of specific job opportunities we have to offer.

Send for your copy of "Your Future in Guided Missiles" today.

**Bendix** — prime contractor  
for the **TALOS MISSILE**

Bendix Products Division—Missiles  
403 J, Bendix Drive, South Bend, Indiana  
Gentlemen: I would like more information concerning opportunities in guided missiles. Please send me the booklet "Your Future In Guided Missiles".

NAME \_\_\_\_\_  
ADDRESS \_\_\_\_\_  
CITY \_\_\_\_\_ STATE \_\_\_\_\_



P  
H  
O  
E  
N  
I  
X

At the crossroads of opportunity  
for men with vision in  
Electronic Engineering

**GOODYEAR  
AIRCRAFT  
CORPORATION**  
ELECTRONIC LABORATORY

Arizona Division  
Litchfield Park, Arizona

A Subsidiary of the  
**GOODYEAR TIRE & RUBBER CO**

**WE HAVE OPENINGS  
IN OUR MODERN  
LABORATORIES FOR  
ADVANCED ENGINEERS  
IN ELECTRONIC RESEARCH**

Long range research and  
development projects

University of Arizona graduate  
studies available under company  
financed evening courses.

*Leisure Living At Its Best  
"In the Valley of the Sun"*

Modern Inexpensive Housing

Send resume to: A. E. Manning

Engineering and Scientific Personnel

**GOODYEAR AIRCRAFT**  
LITCHFIELD PARK  
PHOENIX, ARIZONA

Similar opportunities available in  
our  
Akron, Ohio Laboratory



**ENGINEERS—SCIENTISTS****GENERAL ELECTRIC SELECTED TO DEVELOP GUIDANCE AND FIRE CONTROL SYSTEMS FOR NEW NAVY MISSILE, POLARIS**

**New Group Forming as Missile & Ordnance Systems Department of G.E. Adds Navy Project to Nose Cone Development Program.**

**P**OLARIS is the most challenging development undertaken by industry for the Navy since the nuclear propulsion program. It is an Intermediate Range Ballistic Missile, whose specifications call for launching capability from both surface vessels and submarines.

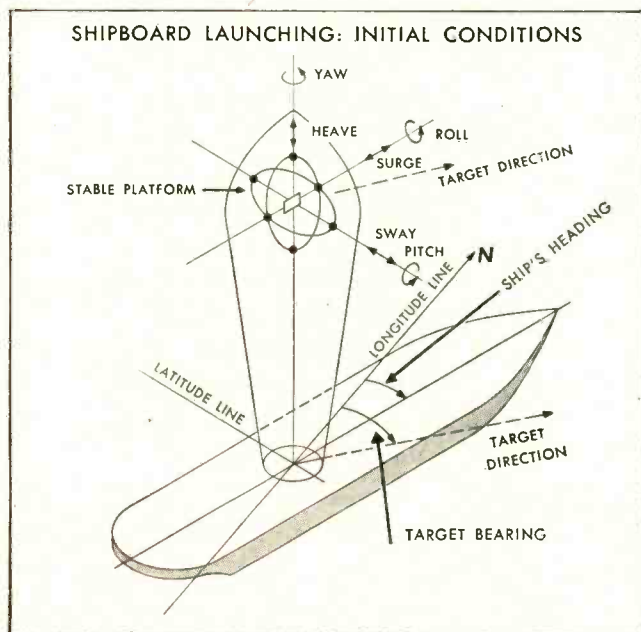
**PROBLEMS UNIQUE IN MISSILE TECHNOLOGY**

The diagram above presents the primary parameters involved in shipboard launching of a ballistic missile in its simplest form.

For Polaris, MOSD must not only surmount these initial conditions but solve fire control problems more complex than heretofore encountered. Pinpoint accuracy in missile guidance is an impressive accomplishment under the most favorable conditions. But how do you achieve it with a missile hurled from a moving platform and aimed at an object approximately 1,500 nautical miles away?

In addition, the Polaris guidance and fire control systems must also operate effectively under the difficult conditions created by submarine launching.

**HOW IS MOSD EQUIPPED TO SOLVE THESE PROBLEMS?**

As prime contractor for IRBM and ICBM Nose Cone Development, MOSD can draw on a reservoir of top level experience and skill. This G-E department also has a backlog of significant experience in the development and manufacture of Naval Fire Control Equipment, such as range-finders, computers and radar antennas.

**NEW OPPORTUNITIES FOR ENGINEERS  
WITH EXPERIENCE IN THE DEVELOPMENT  
OF GUIDANCE & FIRE CONTROL SYSTEMS**

A new group is now being formed to work on Polaris Missile Sub-Systems at MOSD. It will be located at Pittsfield, Mass. in the heart of the Berkshire resort and vacation area. Openings are at all levels for men with experience in:

**GUIDANCE & ELECTRO-MECHANICAL COMPONENTS**

Design, evaluation of guidance and fire control equipment  
Design, development of electro-mechanical components and servomechanisms

Design, development, evaluation of inertial components, synchros, pick-offs, accelerometers, stable platforms, platform gimbals, verticals, etc.

Design, development, fabrication of analog computers for guidance and fire control systems

**GUIDANCE & CONTROL SYSTEMS**

Mathematical analysis; feasibility study of control systems and techniques

Synthesis, design, evaluation of guidance and fire control systems  
Laboratory development, testing, modification of control systems

**ELECTRICAL & ELECTRONIC COMPONENTS**

Development of amplifiers and associated circuitry

Development, packing of electronic, magnetic, transistor servo type circuits and components

Reliability, evaluation, analysis of electronic circuits and components

Design, development of fire control consoles

Systems integration, design of electrical and electronic components

Development of electronic and solid state devices, semi-conductors, new transistor applications

**OPPORTUNITIES OPEN ON OTHER MISSILE PROGRAMS**

Engineers and Scientists with experience in other areas of Electrical Engineering, Aeronautical Engineering, Aerodynamics, Mechanical Engineering, Physics or Mathematics should inquire about positions on other missile programs at Missile and Ordnance Systems Department.

**AN INVITATION**

If you would like to contribute to any of the advanced missile development programs at MOSD, you are invited to send a resume of your education and experience. Or write us for a convenient application form. All resumes will be carefully reviewed by the MANAGERS of our various technical components. You will be invited to visit our offices and discuss work we are doing directly with the Manager with whom you will be working. Communications will be entirely confidential.

Please send resume to Mr. John Watt,

Room 595-13

**MISSILE & ORDNANCE SYSTEMS DEPARTMENT**

**GENERAL ELECTRIC**

1617 Pennsylvania Blvd., Philadelphia 3, Penna.

# ENGINEERS!

**ARE YOU  
LOOKING FOR  
DIVERSITY?**

You can work in these fields

at **Bendix**

in Southern California

Telemetering

Servo Valves

Airborne Radar

Miniature Electric Motors

Missile Guidance

Underwater Sonar

Industrial Sonics

Aircraft Hydraulics

Bendix-Pacific offers you this broad cross section of absorbing tasks.

Here, in Southern California, you will find excellent positions open for electronic, hydraulic and mechanical engineers at all levels. At Bendix-Pacific the diversity of work never traps you in the monotony of a one-product job.

Write us today or mail the handy coupon for complete information.

W. C. Walker, Engineering Employment Mgr.  
Pacific Division, Bendix Aviation Corp.  
11608 Sherman Way, North Hollywood, Calif.

I am interested in this engineering field\_\_\_\_  
I am a graduate engineer with \_\_\_\_ degree.  
I am not a graduate engineer but have \_\_\_\_  
years experience.

Name \_\_\_\_\_  
Address \_\_\_\_\_  
City \_\_\_\_\_  
Zone \_\_\_\_\_ State \_\_\_\_\_

ENGINEERS • PHYSICISTS

*Big things  
are happening*

in

**MOTOROLA's**

Chicago Civilian Research  
and Development Laboratories

- Industrial Communications Equipment
- Consumer Products

Here is opportunity *unlimited* for men who like challenges and the rewards that go with accomplishment in non-military engineering assignments. This is your opportunity to advance your career while working in well instrumented laboratories and enjoying the benefits from association with men of the highest technical competence. There are many liberal employee benefits, including an attractive profit sharing plan.

You'll like living in one of the beautiful suburbs of the playground of the midwest, where there are endless social, cultural, and educational activities to choose from the year-round. Exciting life or quiet life—Chicago offers either.

Salary levels are open and commensurate with ability. Directly related engineering experience is *not* needed.

**POSITIONS AVAILABLE IN:**

- Two-way communications • Portable communications • Radio & TV (color)
- Component engineering • Transistor research and application • Microwave systems • Servo-mechanisms • Field engineering • Communications Sales Engineering • Field service engineering

For full discussion of these opportunities — Write:

Mr. L. B. Wrenn, Dept. A

MOTOROLA, INC.

4501 Augusta Blvd., Chicago 51, Ill.



**MOTOROLA**



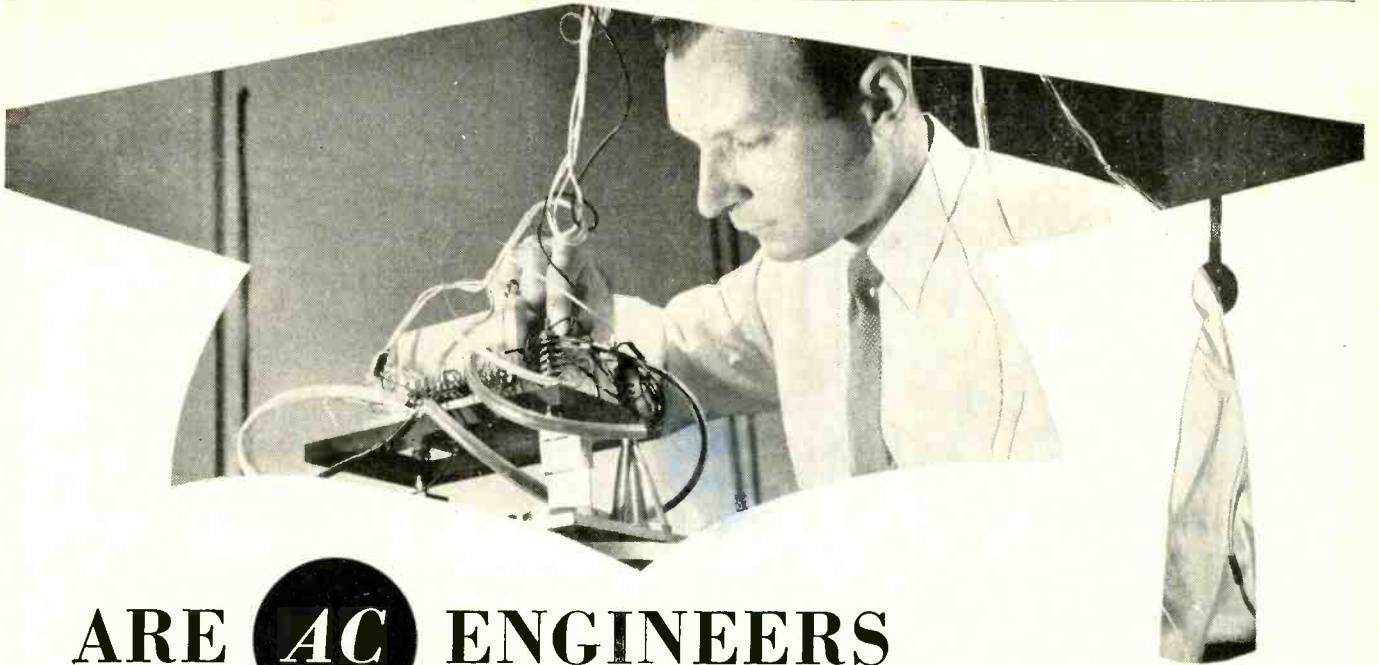

# ARE **AC** ENGINEERS really smarter?

Many are the absolute top men in their respective fields.

Currently, we are actively engaged in the fields of Avionics, Missile Guidance, (IRBM), Computers (Digital and Analog), Jet Engine Fuel Controls, Land to Air—Shore-to-Ship Communication Equipment, etc.

We are permanently dedicated to RESEARCH and DEVELOPMENT in every conceivable field of ELECTRONICS.

Opportunities for your personal development are unlimited. G.M.'s policy of decentralization creates exceptional opportunity for individual advancement. Starting wages are high, you work with the finest of equipment on challenging problems. Construction is already under way for an additional plant (225,000 square feet) in an exclusive Milwaukee suburb.

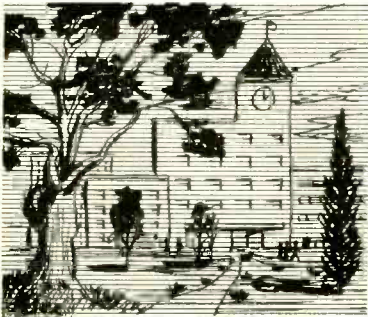

## MASTER'S DEGREE GRADUATE PROGRAM

AC has worked out a Master's Degree Graduate Program (evenings) at the University of Wisconsin, Milwaukee. AC pays all tuition fees for this program.

Undergraduate programs are also available at Wisconsin, Marquette and Milwaukee School of Engineering.

For your future's sake, you too be smart—send for complete facts and employment application form to Mr. Cecil E. Sundeen, Supervisor of Technical Employment.

**AC THE ELECTRONICS DIVISION**  
**GENERAL MOTORS CORP.**

Milwaukee 2, Wis.

Flint 2, Mich.

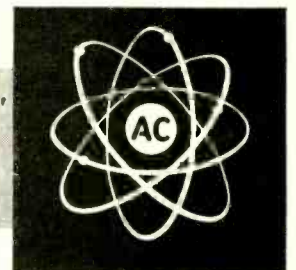

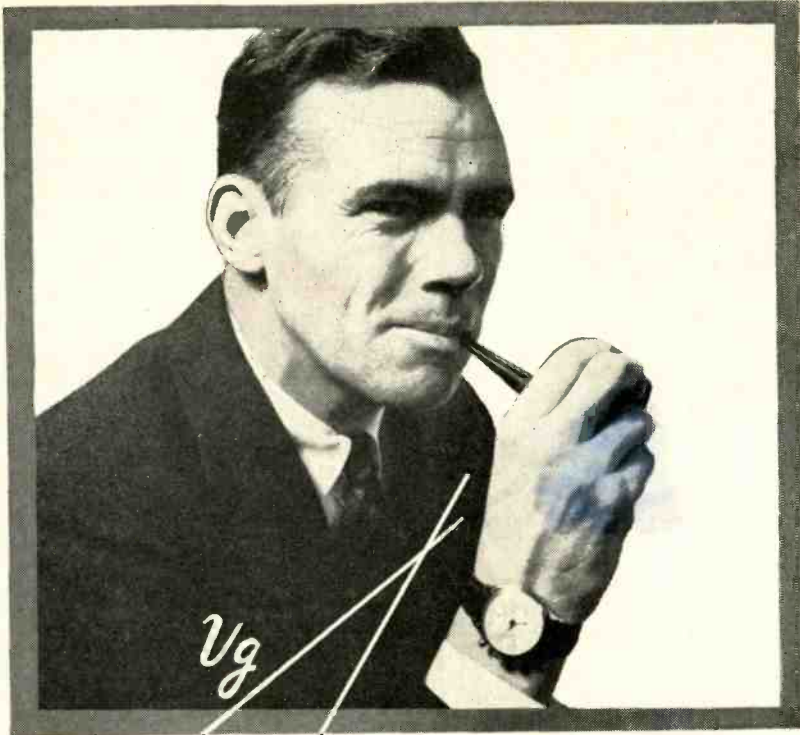

**drift zero**

One of the remarkable achievements of the revolutionary GPL Doppler air navigation systems is that they reduce drift to zero. We believe that GPL can reduce your personal "career drift" to zero, too.

GPL was formed in 1945 with a nucleus of 25 engineers from MIT's famed wartime Radiation Laboratory. Today GPL employs 2,000 people, most of whom work at our beautiful 69-acre estate at Pleasantville, just 35 miles north of New York City.

With two new engineering buildings under construction, a hefty backlog of orders, recognized leadership in several

fields of electronics and research going on into many new ones, the future of GPL is extremely bright.

Besides the top pay and beautiful suburban environment, GPL engineers enjoy many other benefits: a professional atmosphere, small working groups that ensure individual recognition, and the finest facilities that money can buy. They benefit, too, from GPL membership in the nationwide GPE Group.

If you are interested in a "drift-free" career—a career that keeps moving ahead along a straight line of accomplishment—why not call or write to us today?

We have openings in the following categories:

**re: DOPPLER & INERTIAL Air Navigation and Guidance Systems**

**Radar:**

Project Engineering,  
Research, Design  
**Field Engineering**  
at Military Sites and  
Airframe Mfrs' Plants

Research • Design • Development • Applications  
Systems Analysis • Systems Test  
Mechanical Design • Test Engineering  
Microwave Techniques • Servos  
Magnetic Amplifiers • IF Amplifiers  
Pulse Circuitry • Transistorization

For interviews call Mr. Richard E. Höffman,  
ROgers 9-5000 (ext. 435)  
or write:



**General Precision Laboratory Incorporated**

63 Bedford Road, Pleasantville, New York

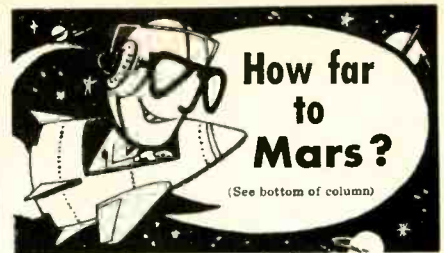

Electronic Engineers  
Mechanical Engineers  
*Advancement... Security*  
*...Responsibility*

Professional personnel needed at all levels to fill responsible openings at this steadily expanding Division of Bendix Aviation Corporation. It's your chance to get specific assignments at the peak of the art in ELECTRONICS and MICRO-WAVE DEVELOPMENT and DESIGN. Good salaries, all employee benefits, ideal suburban living conditions. Whether you be a Department Chief or a Junior Engineer with less than one year's experience, we have the opening and the shoes for you to fill.

Address: Chief Engineer Dept. H

**Bendix**  
AVIATION CORPORATION  
**York**  
DIVISION

York, Penna. York 47-2611

Travelling at Mach 10 it would take about 7 months to reach Mars... but we understand that the Martians are prejudiced against hiring foreign engineers, so why bother. Here at ASCOP there are more opportunities for capable men than there are miles to Mars. If you can qualify in the fields listed below, call or write our Technical Personnel Manager.

**ELECTRONIC ENGINEERS**  
Skilled In  
Data Acquisition  
Data Handling  
RF Techniques  
Circuit Design  
Transistor Applications  
Technical Writing

**ASCOP**  
APPLIED SCIENCE CORP.  
OF PRINCETON

16 Wallace Rd., Princeton, N.J.  
Phone PLainsboro 3-4141  
Dept. H, 15551 Cabrito Road  
Van Nuys, Calif.  
Phone State 2-7030



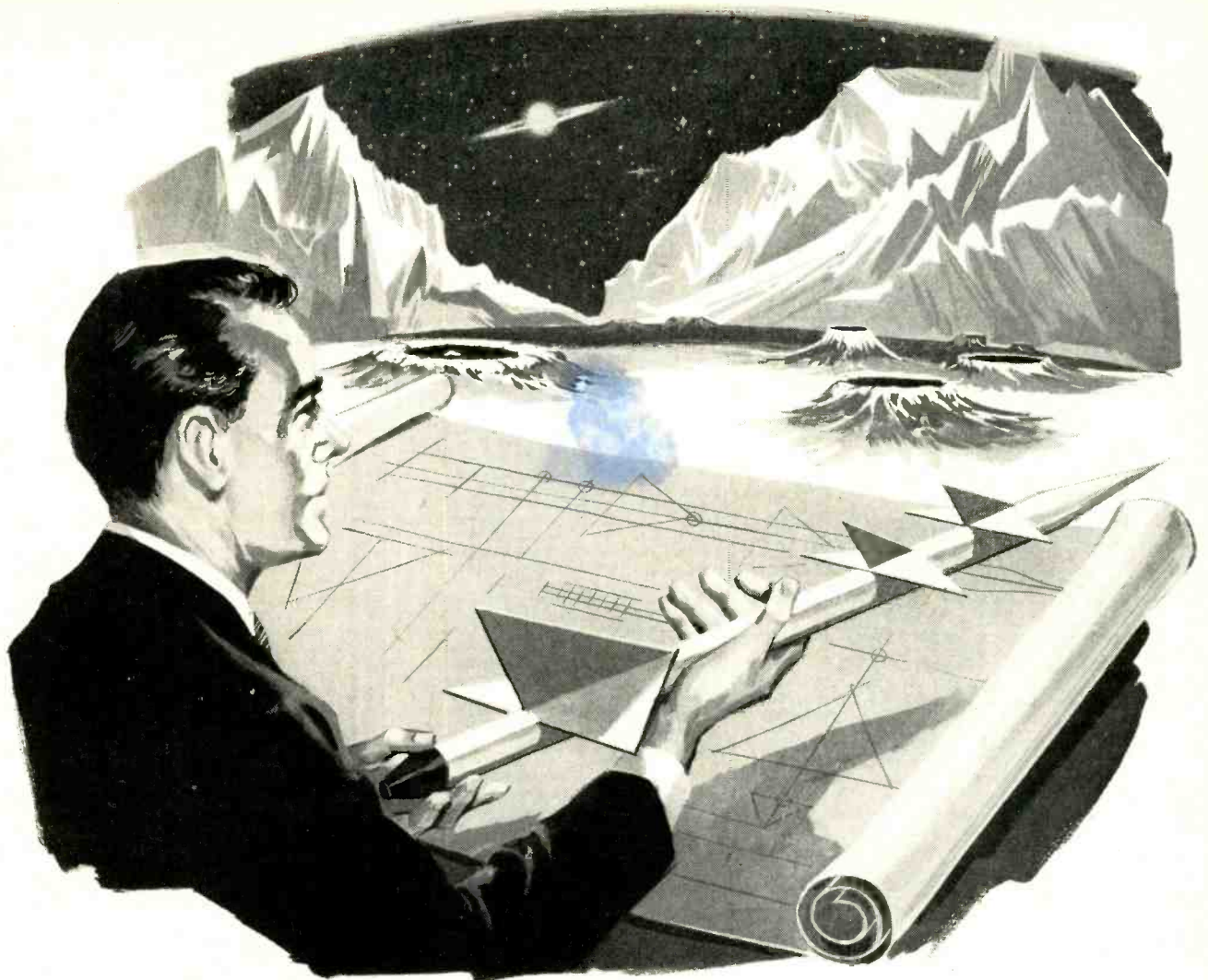

## How to put *Wings* on ideas

**Y**OU'RE an idea man—as are all creative engineers. And like other thoughtful young men, you're eager to lend wings to your visions.

Here at Goodyear Aircraft, we offer an unlimited ceiling for soaring imaginations. Here wait boundless opportunities in your chosen field—whether it be airships, structural materials, electronic equipment, plastics, missile components—or countless other exciting and challenging activities.

Here, too, is an atmosphere in which ideas can gain altitude. For there exist no barriers to individual thought and expression, no height which your inspiration cannot attain. And in fulfillment of their dreams, Goodyear Aircraft engineers can utilize the most modern facilities, including one of the largest computer

laboratories in the world.

If you have faith in your ideas and confidence in your ability to make them work, a rewarding career can be yours at Goodyear Aircraft. Our continued growth and diversification have required expansion of our engineering staffs in all specialties at both Akron, Ohio, and Litchfield Park, Arizona.

Salaries and benefits are, of course, liberal. And if you wish to continue your academic studies, company-paid tuition courses leading to advanced degrees are available at nearby colleges.

For further information on your career opportunities at Goodyear Aircraft, write: Mr. C. G. Jones, Personnel Dept., Goodyear Aircraft Corporation, Akron 15, Ohio.

They're doing big things at **GOODYEAR AIRCRAFT**

*The Team To Team With in Aeronautics*



BURROUGHS RESEARCH CENTER NEEDS *Good* ENGINEERS

**ALL THINGS  
ARE BORN  
IN THE MIND  
OF MAN**

*... it is the responsibility of the engineer to develop these thoughts for practical, profitable use.*

All ideas are but a result of what has gone before and man's ability to adapt his vast store of acquired fact to reason. His mind, when used efficiently, is the most prolific of all computers — it can think, remember, reason and store information better than any man-made machine. This deep reservoir of conscious and unconscious knowledge residing within the thinking individual is a scarcely tapped source of a whole torrent of ideas.

As these new ideas unfold, it will be the responsibility of the engineer and scientist to apply his practical experience and trained reasoning to these new concepts . . . to develop them for the most practical and beneficial use.

That is *just* what we are doing at the Burroughs Research Center. If you want to be a part of these exciting discoveries in the field of electronic computing, why not look into the Burroughs story today?

*Inquiries are invited from those qualified as*

- ELECTRICAL ENGINEERS
- ELECTROMECHANICAL ENGINEERS
- PHYSICISTS • MATHEMATICIANS
- MECHANICAL DESIGN ENGINEERS
- MECHANICAL ENGINEERS



*Write or Telephone*

**M. E. JENKINS, PLACEMENT MANAGER • PAOLI 4700**  
*For Interview at Your Convenience*

**BURROUGHS CORPORATION**  
*Research Center*

PAOLI, PA. • On Philadelphia's Main Line Near Historic Valley Forge

ENGINEERS

FOR A  
BETTER CAREER

You want the best professional help in any career move. When you rely on Abbott's, you get more than professional help—you get a PERSONAL AGENT, using 33 years' experience, wide resources and a distinguished clientele to make sure your move is the right one.

**CHIEF MISSILES ENGINEER**—research & development

**SUPERVISORY ENGINEERS**—Ph.D. level—electronics research, nuclear energy, aircraft & missile propulsion and propellants.

**PROJECT ENGINEERS**—EE, design & development electronic equipment, radar, fire control, gyros, servos, microwave, control instruments.

**PROJECT SUPERVISOR**—electromechanical instrumentation, experience in ring bearings & optics.

**CONTROL SYSTEMS ENGINEERS**—NUCLEAR REACTORS—feedback systems, components test, control circuitry, instrument systems.

**SALARIES—\$10,000 to \$20,000**

Of course, your reply will be held strictly confidential, and our client companies will assume all expenses and our service charges. Please send 3 copies of your resume to Mr. George R. Sandel, Director.



EMPLOYMENT SPECIALISTS  
233 Washington Street, Boston 8, Mass.

**QUICK SOLUTION  
to  
MAN POWER  
PROBLEMS**

through the EMPLOYMENT OPPORTUNITIES SECTION of this publication. The market place for those offering or wanting the services of men on engineering, technical and executive level.

This section offers a quick, effective solution to your man power problems. Because its readership is confined to just the type of men you need, waste circulation is avoided . . . You reach only the men you want.

**CLASSIFIED ADVERTISING  
DIVISION**

**ELECTRONICS**  
330 WEST 42ND ST.  
NEW YORK 36, N. Y.



**HERE  
IS A  
BIG  
JOB...**

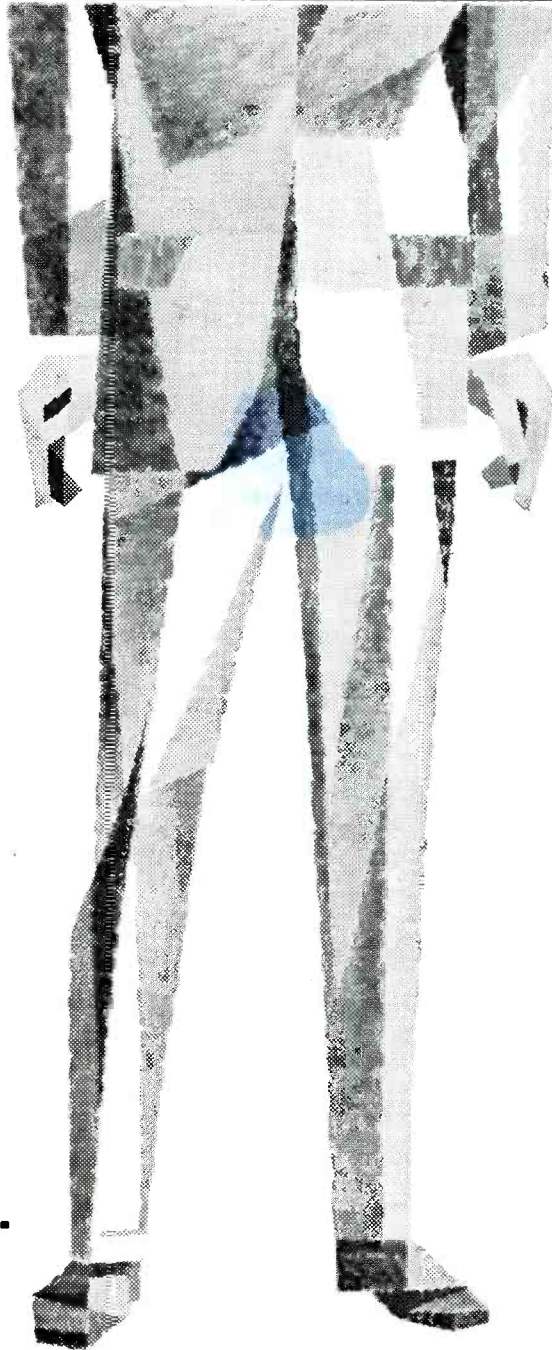

How "big" are you?

Years of experience are not the only yardstick . . . some men grow faster in a year than others in a whole career.

You should have an engineering degree, either electrical or mechanical . . . or a degree in physics.

You will work on projects of electronics . . . embracing instrumentation, automation, and nuclear science.

Brown Instruments Division is the world's leading designer and builder in this field . . . and a job here offers every-

thing in salary, superior personnel policies, and extra benefits that you would expect of a leader . . . plus advancement opportunities limited only by your own capacity.

Ask yourself whether you qualify. Our standards are very high . . . if yours are too, we think you'd be happy here.

To inquire, just write your name, address and home telephone number on a card, send it in . . . address it, please, to Mr. Dan Garvey . . . we'll get in touch with you.



**Good Company** — at Brown, you'll work with such men as John Metzger, B.E.E., Villanova University. With Brown 5 years, John is Assistant Section Head of Information Center—Application Engineering Division.



**Honeywell** BROWN INSTRUMENTS DIVISION

Wayne & Windrim Avenues • Philadelphia 44, Pa.

*First in Controls*

# SERVO DESIGN and SYSTEM ENGINEERS

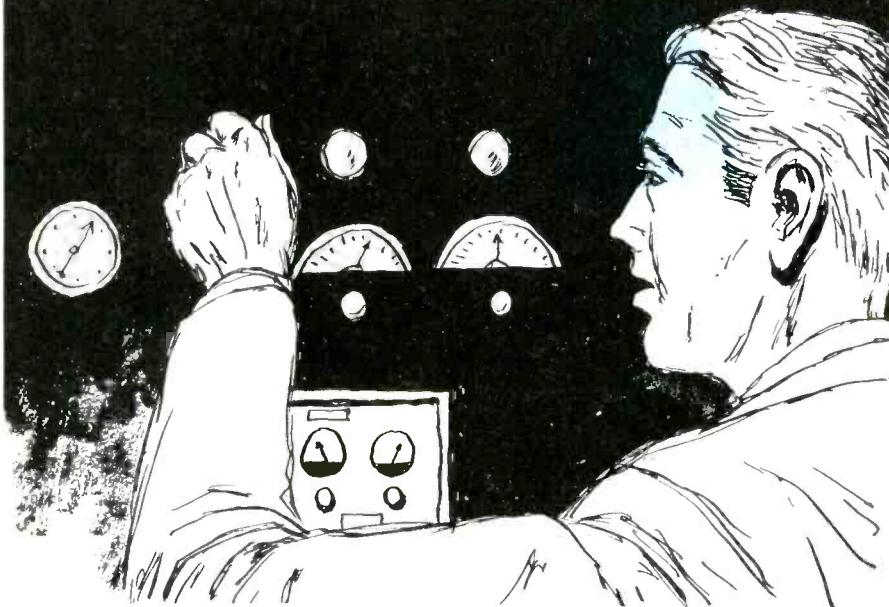

We need an experienced servo design engineer to assume a prime responsibility in a new systems activity. Other attractive engineering opportunities are also available in this new program.

Enjoy challenging opportunities in the analysis and design of electro-mechanical servo loops, including laboratory experimentation and system development.

Work with the top men in the field and with the finest test, research and development facilities. New plant being added in suburban Milwaukee as a part of Major, Permanent, Expansion Program.

AC will provide financial assistance towards your Master's Degree. A Graduate Program is available evenings at the University of Wisconsin—Milwaukee.

GM's long-standing policy of decentralization creates individual opportunity and recognition for each Engineer hired.

You will enjoy, as will your family, Milwaukee's "small town" friendliness and metropolitan shopping and cultural advantages.



For immediate, confidential interview in your area or an invitation to visit Milwaukee—see our plant—talk with our engineering heads and discuss your possibilities, contact:

Mr. Cecil F. Sundeen,  
Supervisor of Technical Employment

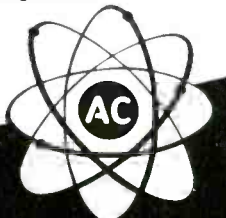

**AC the Electronics Division**  
**GENERAL MOTORS Corporation**

Flint 2, Mich.

Milwaukee 2, Wis.

## FIELD ENGINEERS

### Sylvania's Expansion Creates New Opportunities In U. S. & Overseas

Become part of our field operations team. Assignments involve installation of Sylvania equipment in the field, engineering tests of our electronic systems, field training of military personnel and technical assistance with field problems. These are challenging opportunities with Sylvania - developed electronic equipment.

Field assignments are open now in communications and electronic countermeasure systems, both in the U. S. and at Overseas sites. Duration in the field varies from one month to over a year.

Excellent salaries plus extra compensation and expense account while in the field. Additional compensation for Overseas assignments.

Advancement and salary review based on merit; group insurance and retirement programs. Extra insurance coverage while in the field.

Applicants should have BS/EE degree and experience in radar and communications equipment, preferably military equipment.

*For more detailed information on these opportunities, please send your complete resume to:*

Paul F. Kent

*Electronic Defense Laboratory*



*Box 205—Mountain View, California*

## SYSTEMS SALES REPS

Electronics Instrumentation and data processing systems manufacturer wants sales representation in major government and industrial areas. Retainer and/or commission. Send details of experience, contacts and territory to:

**RW-5587, Electronics,**  
Class. Adv. Div., P.O. Box 12 N.Y. 36, N.Y.

## NEED ENGINEERS?

An employment advertisement in this EMPLOYMENT OPPORTUNITIES section will help you find the engineers you need. It's an inexpensive, time saving method of selecting competent personnel for every engineering job in the electronics field. The selective circulation of ELECTRONICS offers you an opportunity to choose the best qualified men available.



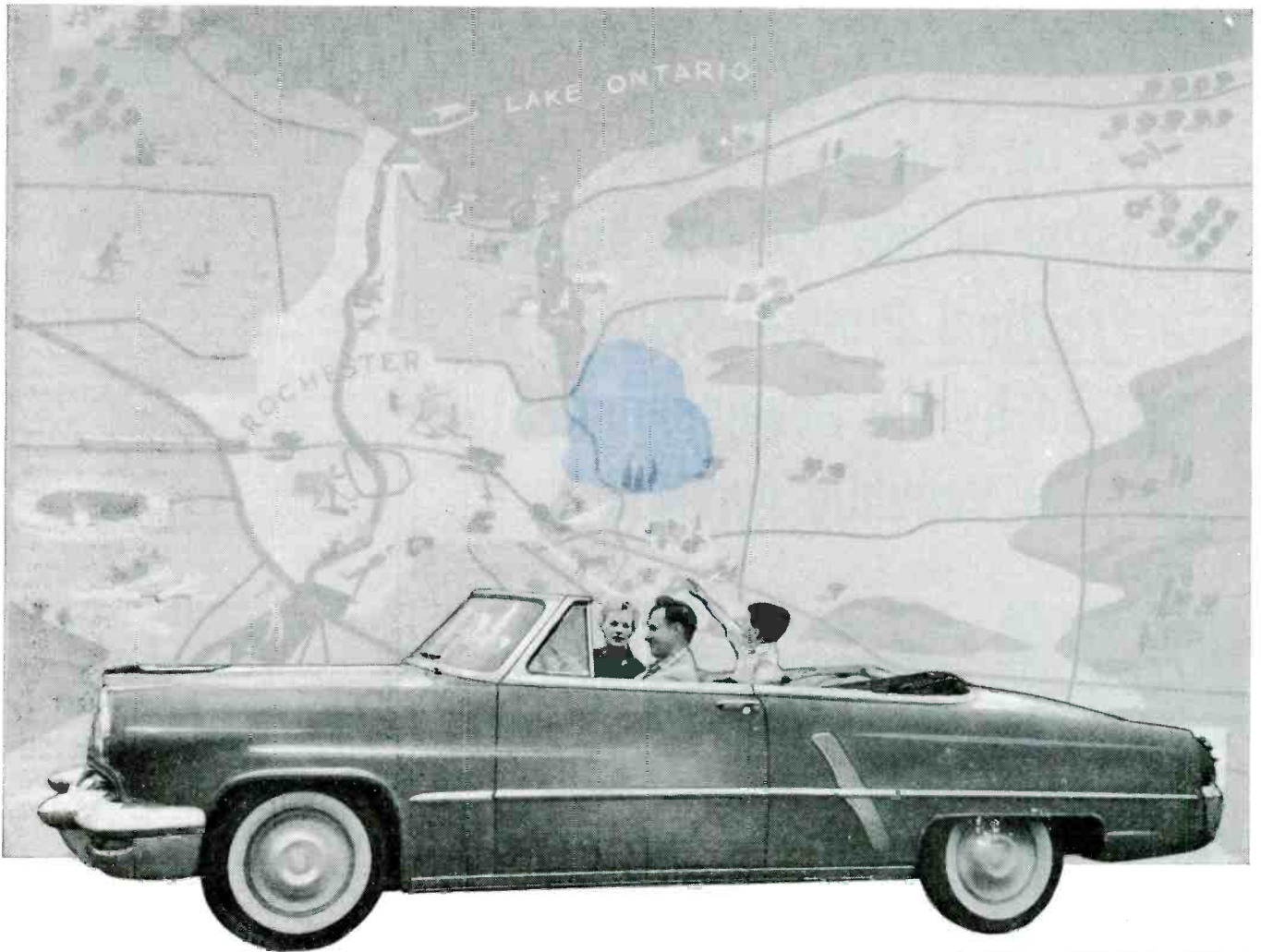

## ELECTRONICS ENGINEERS...

*Vacationing upstate...or passing through?*

### COME IN AND SEE US ABOUT YOUR FUTURE

Whether you're headed for one of upstate New York's many beautiful vacation spots—or just passing through this area—please stop and be our guest!

We'd like to show you and your family our facilities and have you meet some of our people. We want to tell you what the future can hold for you at Stromberg-Carlson. We'll be happy to pay your expenses the day you're visiting us.

What about your future here? First, you can be sure of getting the *recognition* you deserve as a professional en-

gineer. You'll be equally sure of rapid personal growth in a company which is in the midst of a planned threefold expansion.

You'll be assured of excellent starting salary and quick advancement... fully subsidized graduate study... ideal living conditions in a city of beautiful homes, outstanding schools, and vast facilities for culture and recreation.

Check the list at the right to see where your future lies. To arrange a visit when you're in our area, phone or write:

ARTHUR N. PAUL, *Director of Technical Personnel*

**STROMBERG-CARLSON**

A DIVISION OF GENERAL DYNAMICS CORPORATION

1458 N. Goodman Street • Rochester 21, New York



Electronic Communication Systems

Telecommunications  
Switching Circuits  
Carrier Circuits  
Equipment Engineering  
Equipment Design  
Apparatus Design

Data Processing  
Solid State Digital  
Computer Systems

Electroacoustics  
Mathematicians—  
Operations Research

Physical Chemistry  
Electromechanical Design  
Radar and Countermeasures  
Missile Guidance Systems  
Production

Microwave Circuits  
Navigation Systems  
System Test Equipment

Technical Writers  
Test Equipment Design  
Quality Control  
Industrial Engineers  
Sales Engineers

**NEW POSITIONS FOR  
ENGINEERS AND SCIENTISTS**

**Interested in the Holistic Approach  
to Practical Problem Solving as  
Practiced by the Development Staff  
of Republic Aviation**

**COMBAT  
OPERATIONS  
ANALYSIS**

*Work involves analysis of advanced weapons systems, prediction of weapons effectiveness in various countermeasure environments, penetration tactics analysis and associated studies.*

**ELECTRONICS**

*To conceive, analyze and develop new systems for detecting and neutralizing military targets using electronic techniques available in any part of the electromagnetic spectrum.*

**Problems in both areas have application from zero velocity of VTOL craft to ballistic and hypersonic glide vehicles and weapons.**

Men able to take the holistic approach—and able, as well, to keep practical objectives always in mind—will discover these staff openings offer excellent reward and opportunity for continued professional growth with the creators of the XF-103 and the F-105B Thunderchief...most powerful supersonic fighter-bomber — designed and built under the Weapons System Concept. Graduate engineers with various ranges of experience will find work levels commensurate with training and ability.

*Salaries are highly competitive, benefits advanced and comprehensive. The location is Long Island, prime area on the Atlantic seaboard for working, living, relaxing.*

Send a comprehensive resume today to  
**MR. GEORGE R. HICKMAN, ENGINEERING EMPLOYMENT MANAGER**  
*You will receive a prompt, personal reply.*



**REPUBLIC AVIATION**

Farmingdale 10, Long Island, New York

**UNDERWATER ORDNANCE  
MISSILE SYSTEMS**

**Research and Development**

Design electronic and mechanical control circuits for use in underwater acoustic homing devices and systems such as torpedoes, targets and decoys.

We have openings for engineers with either advanced or limited experience. There are openings in both Cleveland, Ohio and Key West, Florida.

Clevite Research Center develops new principles and new products for other units of Clevite Corporation. The Research Center provides the ideal environment for the engineer because it has been supplied with the facilities, equipment and library to provide new knowledge and new products for Clevite Corporation, a company whose entire product line is in the growth fields of electronics, semiconductors and automotive and aircraft power plants.

**WRITE E. A. GENTRY or**

**CALL Ulster 1-5500 COLLECT**

**GLEVITE RESEARCH CENTER**

540 East 105th Street  
Cleveland 8, Ohio

**UNIVERSITY OF MIAMI  
MARINE LABORATORY**

Electrical Engineers or Physicists with suitable interests and experience are needed for research in underwater acoustics, sonar, and instrumentation. Address: Director.

The Marine Laboratory  
University of Miami  
Coral Gables, Florida

**GLASS  
ENGINEER**

Experienced in the vacuum tube industry on both hard and soft glass. Knowledge required of automatic sealing and stem-making machines.

Capable of aiding in the solution of production glass problems as they arise. Excellent opportunity with one of America's fast growing electronics companies.

*Write, sending resume, or call for interview*

**CHATHAM ELECTRONICS**

(Div. of TUNG-SOL ELECTRIC, INC.)

LIVINGSTON, NEW JERSEY  
LI 6-1100



ENGINEERS AND SCIENTISTS: EE's, ME's, Physicists

anyone can  
make claims,  
but here's  
proof

number 3 of a series of six

## GENERAL ELECTRIC'S HEAVY MILITARY ELECTRONIC EQUIPMENT DEPARTMENT

*offers a basic challenge  
to your ability*

Are you looking for a challenge? Please don't consider this as the usual cliché. We mean a definite, basic challenge to your abilities!

can you  
meet  
challenges  
like these?

Here is an antenna so large that to rotate it (by actual calculation) would require two 2500 hp locomotives running on a circular track 300 feet in diameter at 60 mph. Could you devise a more practical way?

MTI separates, supposedly, moving targets from stationary or slow moving backgrounds. Now we want to pick off—with high resolution—stationary targets from stationary backgrounds. What ideas can you add to ours?

Here is a ballistics missile. It is only as good as its guidance system. Could you "groove" it so as to be on target at the end of an inter-continental flight?

Could you combine the functions of two modern radar systems into one system which would—

1. Double the range? 2. Treble the height capabilities?
3. Speed the data rate? 4. Increase the accuracy?

Could you conceive the system necessary for complete, automatic detection and direction of all air traffic in a given volume of space—with all its attendant requirements of data gathering, data processing, 3-dimensional data display, data link?

If you can, HMEE needs you as much as you need us! We need you because people like you are hard to find. It's that simple.

And you need us because these typify the challenges to be found at Heavy Military.

Of course there are other advantages to be found at HMEE. Our proved long-range stability...our 3-way program for professional development, including our 100% Tuition Refund plan for advanced study at Syracuse University...life, accident and medical insurance...and many other benefits.

*At the present time, we have more than 75 unfilled assignments in:*

MARINE AND ORDNANCE RADAR • GROUND RADAR • SONAR • COMMUNICATIONS AND DATA HANDLING • MISSILE GUIDANCE AND CONTROL AIRBORNE EQUIPMENTS

**Interested?** Then take a few minutes to write us about your background...education...experience...and, most important, your interests. We'll respond promptly.

Write in complete confidence to: Mr. George B. Callender, Dept. 27-H

HEAVY MILITARY ELECTRONIC EQUIPMENT DEPT.

GENERAL  ELECTRIC

Court Street, Syracuse, New York

**NU**  
**U of C**  
**IIT**

Complete your training at  
Chicago's top technical centers

**Admiral**<sup>®</sup>

College tuition refund plan

Match your  
interests to this check list of  
**ENGINEERING OPPORTUNITIES**  
with  
**Admiral**<sup>®</sup>

Research and development projects, now in progress, have gained for Admiral a commanding lead in certain broad areas of military and civilian electronics. A number of challenging opportunities exist, and one of them may closely match your special interests and past experience. Examine the following check list.

**COMMUNICATIONS**—Design of airborne, automatic tuned communication systems. FM, AM and SSB considerations are involved. Transistor applications in power, audio and control circuits.

**COUNTERMEASURES**—Receiver and transmitter design throughout the communications, navigation and radar frequencies. Antenna, servo, pulse generators and transistor applications work available in a wide range of techniques.

**RADAR**—X band fire control. Design engineers with experience in IF systems, doppler techniques and micro-wave signal generation and detection.

**L band identification.** Development of equipment using pulse train systems of advanced coding requirements. Design of standard power measuring systems and radar test sets. Thermal control in tightly packaged equipment.

**MILITARY TELEVISION**—Transmitter design through VHF and UHF range. Camera design and transistor application throughout the video and synchronizing sections of airborne equipment.

**PALO ALTO RESEARCH**—Development of new technologies opens door on a program of advanced research in aeronautical electronics. Experienced and intermediate level engineers send resume and salary requirements to R. M. Jones, Admiral Corporation, 901 California Ave., Palo Alto, Cal. . . for California openings only.

Current openings offer excellent income and opportunity for rapid advancement. Complete employee benefit program includes retirement plan, paid group insurance, college tuition refund plan and ideal working conditions. On-the-job training for junior and intermediate engineers. Write, summarizing your education and experience to John Harlan, Personnel Division.

**Admiral Corporation**

3801 W. ARMITAGE AVE., CHICAGO 47, ILL.

**FOR RATES  
OR INFORMATION**

About Classified  
Advertising,

Contact

*The McGraw-Hill  
Office Nearest You.*

ATLANTA, 3  
1301 Rhodes-Haverty Bldg.  
JACKSON 3-6951  
R. POWELL

BOSTON, 16  
350 Park Square  
HUBBARD 2-7160

CHICAGO, 11  
520 No. Michigan Ave.  
MOHAWK 4-5800  
W. HIGGINS  
J. BRENNAN

CINCINNATI, 37  
1825 Yorktown Road  
Swifton Village, Apt. 2  
G. MILLER

CLEVELAND, 15  
1510 Hanna Bldg.  
SUPERIOR 1-7000  
W. SULLIVAN

DALLAS, 2  
901 Vaughan Bldg.,  
RIVERSIDE 7-5117  
G. JONES  
E. SHIRMER

DETROIT, 26  
856 Penobscot Bldg.  
WOODWARD 2-1793  
W. STONE

LOS ANGELES, 17  
1125 W. 6 St.  
MADISON 6-9351  
C. DYSINGER  
D. McMILLAN

NEW YORK, 36  
500 Fifth Ave.  
OXFORD 5-5959  
S. HENRY  
D. COSTER  
R. LAWLESS

PHILADELPHIA, 3  
17th & Sansom St.  
RITTENHOUSE 6-0670  
H. BOZARTH  
R. EDSALL

ST. LOUIS, 8  
3615 Olive St.  
JEFFERSON 5-4867  
W. HIGGINS

SAN FRANCISCO, 4  
68 Post St.  
DOUGLAS 2-4600  
R. ALCORN



ELECTRONICS &amp; COMMUNICATIONS ENGINEERS



NATIONAL



BOSTON



## VACATIONING IN NEW ENGLAND?

Be our  
Guest  
for a day!

Whether it's the landlocked salmon down east, the sun and surf of the Cape, or the Tanglewood sessions in the Berkshires that you're heading for —why not plan on spending a day as National's guest while you're in New England?

We'd like to show you our facilities, have you meet some of our men, sit down and talk over what is doing at National and what it can really mean for you.

**Just call us collect at Malden 2-7950.** Ask for Mr. F. M. Swope. We will make complete arrangements for interviews.

Or, if you prefer, drop us a line now. Tell us when you expect to be near Boston—we'll arrange a day at National for you.

If you are an electronics, communications or radio engineer, or physicist, with more than ordinary qualifications, you'll find excellent positions at National in:

**FREQUENCY STANDARD DEVELOPMENT\* • MULTI-PATH TRANSMISSION TECHNIQUES • TROPOSPHERIC & IONOSPHERIC FORWARD PROPAGATION SCATTER SYSTEMS • SINGLE SIDEBAND EQUIPMENTS • MOLECULAR BEAM TECHNIQUES • CODING & SIGNAL PROCESSING EQUIPMENT • FREQUENCY SYNTHESIZED STABLE COMMUNICATION EQUIPMENTS**

Salaries are fully commensurate with ability and training. Benefits are broad and include opportunities for advanced degree work at some of the nation's top engineering schools.

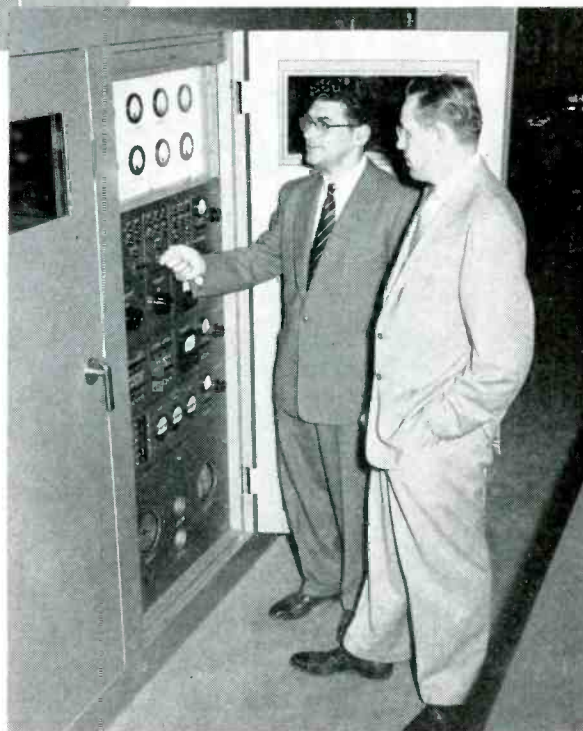

**National**  
EST. 1914

**NATIONAL COMPANY, INC.**  
61 Sherman Street, Malden, Massachusetts

\*National's engineers have produced the Atomichron frequency standard. Based on cesium resonance, it has accuracy of 1 in 10<sup>10</sup>—equivalent to 1 second in 300 years.

# We're next door to a Great Educational Institution

The rapidly expanding Bendix Systems Division of Bendix Aviation Corporation was formed to integrate Bendix skills and facilities and serve as a focal point for systems planning, development and management.

After very careful study of many locations, it was decided that 56 acres adjacent to the new North Campus of the University of Michigan in Ann Arbor offered the best combination of optimum living conditions and professional environment. Our staff members are encouraged and assisted in advancing their education, and because of our proximity to the University our people are able to attend daytime classes.

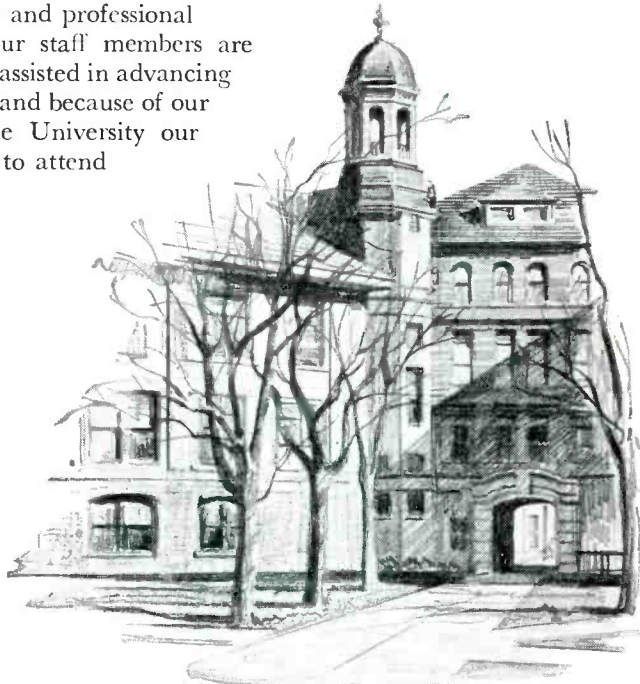

West Engineering Arch—University of Michigan

In addition, of course, Ann Arbor is noted for its world-famed University of Michigan Medical Center. Its new \$7,500,000 high school is regarded as one of the most elaborate and modern in this country.

Our current needs are for experienced men in:

- SURVEILLANCE & RECONNAISSANCE:** radar, infrared, acoustics
- WEAPONS:** missiles, aircraft subsystems, guidance and control
- DATA PROCESSING:** analog and digital computers, displays
- NUCLEAR:** reactors, propulsion, special weapons
- COMMUNICATIONS:** radio, digital, data links
- NAVIGATION:** radio, inertial, ground-controlled
- COUNTERMEASURES:** ECM, electronic warfare
- OPERATIONS ANALYSIS.**

For an interview, write Dept. B8, or call NORMandy 5-6111.

Attention WESCON visitors! Contact Tony Procassini or Bob Forman at the Sheraton-Palace. Telephone EXbrook 2-8699.

**Systems Division**  
ANN ARBOR, MICHIGAN



For your immediate use  
the 6 most vital assets  
to insure your

## EXECUTIVE SUCCESS



**SUCCESSFUL** executives will tell you this simple fact: certain *key abilities* practically allow a man to write his own pay-check. And one doesn't have to be born with these proven executive qualities—they can be self-developed to a degree you may never have thought possible—easily, and *without* long years of study. You can help yourself acquire them with this specially selected Library of practical executive techniques.

The six books comprising this Library have been selected by successful executive as the ones most useful in developing the six qualities of executive success.

Helps you develop these 6 success qualities:

- Handling People
- Managing Yourself
- Speaking Forcefully
- Writing Clearly
- Working Efficiently
- Thinking Straight

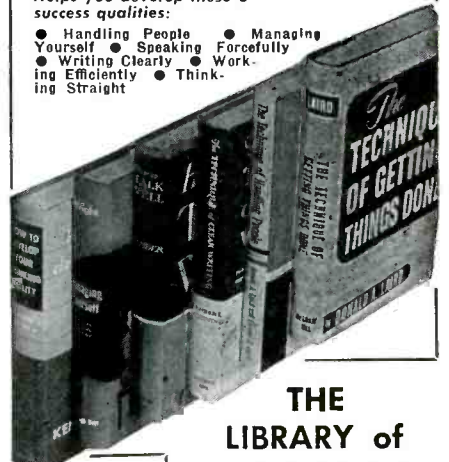

## THE LIBRARY of PRACTICAL EXECUTIVE TECHNIQUES

Library contains these books:

- Managing Yourself by Wright
- The Technique of Getting Things Done by the Lairds
- How to Develop Your Thinking Ability by Keyes
- The Technique of Clear Writing by Gunning
- How to Talk Well by Bender
- The Technique of Handling People by the Lairds

- 6 volumes ● 1633 pages
- \$20.00 — payable \$4.00 in 10 days, then \$4.00 a month

You'll find here the best thinking on a variety of important executive techniques... like getting the best out of your associates, putting you thoughts down clearly and forcefully on paper, speaking with authority in front of people, thinking a job through logically, and getting it done most efficiently. All in all, you have a storehouse of information on doing *best* every job the successful executive must know how to handle.

**SAVE \$4.00.** Bought one at a time, the total price of these books would be \$24.00. Under this special offer, the complete Library is available for only \$20.00—a cash saving of \$4.00. And you also have the privilege of paying for the books on easy terms, while you use them.

## SEE THIS LIBRARY 10 DAYS FREE

McGraw-Hill Book Co., Dept. FL-8/1/57  
327 W. 41st St., N. Y. C. 36

Send me the Library of Practical Executive Techniques for 10 days' examination on approval. In 10 days I will send \$4, then \$4 monthly until \$20 is paid. Otherwise I will return books postpaid.

PRINT  
Name .....

Address .....

City ..... Zone..... State.....

Company .....

Position .....

For price and terms outside U. S., write McGraw-Hill Int'l., N. Y. C. FL-8-1-57



# AN INVITATION TO JOIN ORO

## *Pioneer In Operations Research*

Operations Research is a young science, earning recognition rapidly as a significant aid to decision-making. It employs the services of mathematicians, physicists, economists, engineers, political scientists, psychologists, and others working on teams to synthesize all phases of a problem.

At ORO, a civilian and non-governmental organization, you will become one of a team assigned to vital military problems in the area of tactics, strategy, logistics, weapons systems analysis and communications.

No other Operations Research organization has the broad experience of ORO. Founded in 1948 by Dr. Ellis A. Johnson, pioneer of U. S. Opsearch, ORO's research findings have influenced decision-making on the highest military levels.

Our computer laboratory is equipped with the 1103-A Univac, the "Cadillac" of computers. Encompassing 1200 sq. ft., it is leased at a cost of \$40,000 per month. ORO's professional atmosphere encourages those with initiative and imagination to broaden their scientific capabilities. For example, staff members are taught to "program" their own material for the Univac computer so that they can use its services at any time they so desire.

ORO starting salaries are competitive with those of industry and other private research organizations. Promotions are based solely on merit. The "fringe" benefits offered are ahead of those given by many companies.

The cultural and historical features which attract visitors to Washington, D. C. are but a short drive from the pleasant Chevy Chase suburb in which ORO is located. Attractive homes and apartments are within walking distance and readily available in all price ranges. Schools are excellent.

For further information write:  
Professional Appointments

## OPERATIONS RESEARCH OFFICE **ORO**

The Johns Hopkins University  
7100 CONNECTICUT AVENUE  
CHEVY CHASE, MARYLAND



Your Future Limited?  
Not in missile testing  
as an **RCA ENGINEER**  
at **PATRICK**  
**AIR FORCE BASE**  
in **FLORIDA**



Today, RCA electronic and optical engineers are creating and constantly improving systems to acquire and analyze flight test data on missiles of all capabilities. They provide similar support for the earth satellite, soon to be launched as a feature of International Geophysical Year.

You will find permanent positions in systems development, application and analysis in radar and optical tracking devices, telemetry, communications and data processing equipment.

These are long-range programs . . . filled with opportunity for professional growth with RCA . . . all taking place in Florida's climate that's so appealing year 'round.

Send resume and receive our brochure "You and MTP." Our Engineering Managers will arrange a confidential interview at your convenience.

Mr. H. Storz, Mgr.  
Technical Employment, Dept. N-10H  
RCA Service Co., Inc.  
Missile Test Project  
Mail Unit 114  
Patrick Air Force Base, Florida



**RCA SERVICE COMPANY, INC.**

# TEST ENGINEERS

## WILL YOU REACH YOUR MAXIMUM POTENTIAL?

No matter what your ability, you MUST HAVE the job opportunity and the BEST of TOOLS and FACILITIES to develop your talents to the fullest.

Investigate the Environment created at AC for its Advanced Development Programs on Missile Guidance and Aircraft Fire Control Systems.

### OUR ENVIRONMENTAL LABORATORY

is one of the most versatile laboratories in the country and we are in the process of a Major, Permanent Expansion. 225,000 square feet plant being added in suburban Milwaukee.

Our men enjoy working with the finest of test equipment and lab facilities and with the top men in the field.

We are currently engaged in the following types of Test Activities.

- VIBRATION TESTING
- COMPLEX WAVE ANALYSIS
- LOW TEMPERATURE-ALTITUDE
- HIGH TEMPERATURE
- RELIABILITY EVALUATION
- INSTRUMENTATION

Mr. Cecil E. Sundeen, Supervisor of Technical Employment

THE ELECTRONICS DIVISION

**GENERAL MOTORS Corporation**  
FLINT 2, MICH. MILWAUKEE 2, WIS.

## FREE - \$1,000

—worth of professional service, because you are an electronics engineer

CADILLAC, for thirty years the nation's largest Executive and Professional Placement Service, represents every "Blue Book" Electronics firm in America. Their BEST jobs, at salaries from \$6,000 to \$75,000, appear monthly in our Electronics Opportunities Bulletin. Because you are an Electronics Engineer, BOTH the Bulletin and our COMPLETELY CONFIDENTIAL Placement Service are available to you absolutely FREE OF CHARGE.

For your free Bulletin, each month listing America's BEST Electronics jobs, send your name and address to:

EUGENE B. SHEA  
Electronics Division  
**CADILLAC ASSOCIATES, INC.**  
220 S. State St.—Dept. E1  
Chicago 4, Ill.

### S.E.E. GIVES To ENGINEERS

Free Service in providing contacts for choice positions available now.

### To EMPLOYERS

Automatic access to a wide variety of desirable talent—now and regularly—from wide geographical locations.

Let us demonstrate immediate effectiveness.

SCIENTISTS, ENGINEERS & EXECUTIVES, Inc.  
1026 Seventeenth St., N.W.  
Washington 6, D. C. — METropolitan 8-2749

### ENGINEERS

If you have been looking for an Employment Agency that is skilled in the STATE OF THE ART of Technical Recruitment and RELIABILITY OF INFORMATION concerning positions, why not communicate with us at once! ALL POSITIONS FEE PAID.

FIDELITY PERSONNEL SERVICE  
1218 Chestnut St. Phila. 7, Pa.  
Specialist in Aviation, Electronics and Nuclear

### ELECTRONICS ENGINEER

\$14 to \$18,000 Yr.

Well known company seeks Supervisory Engineers with experience in Computer & Analytical devices. Should have Executive ability, & Technical background.

For Confidential & Prompt Service

Send resume to:

J. COOPER  
202 S. State—Suite 1116 Phone: Harrison 7-6337  
Chicago, Illinois

### ASSISTANT CHIEF ENGINEER

\$13,000 Plus

This is a position not a job. Midwestern Company employing 400 people all phases of electro mechanical development, production, liaison and sales. Company assumes all expenses your confidence respected.

MONARCH PERSONNEL

28 E. Jackson Blvd. Chicago 4, Ill.

### POSITION VACANT

**Electronic Circuit Design Engineers**—Several years experience and graduate training desirable (but not required) for challenging circuit design problems. Ability to work in small, outstanding group on varied high caliber design projects i.e. computer techniques application, data accumulation and reduction pulse, amplifier and discriminator design. Phillips Petroleum Company, Atomic Energy Division, P. O. Box 1259-BH, Idaho Falls, Idaho.

**Personnel Managers**—Need experienced Engineers and Technicians? We offer a booklet especially prepared to help you solve this problem. Write for your "free" copy of "Reservoir of Engineers and Technical Men". Electronics, P. O. Box 12, New York 36, N. Y.

Your engineering ability deserves a future...

# AND HERE'S WHERE YOU WILL FIND IT!

Look ahead to tomorrow and beyond... as engineers always do, always will. Use your ability to the utmost with a world-acclaimed pioneer and leader in commercial electronics. You'll work with and for creative-minded engineers in small groups. You'll know recognized ability is rewarded financially, professionally.

As one of us, you enjoy the best view of electronic frontiers, for they're all around you. Among today's altogether new and stimulating design and development projects, there are these very desirable openings in:

- |  |                           |
|--|---------------------------|
| Advanced Circuit Design                    | Transistors & Magnetics   |
| Electron Microscopes & Diffraction Cameras | Computer Logic            |
| Automatic Control & Inspection Techniques  | Electronic Test Equipment |
| Broadcast Transmitters & Antennas          |                           |

If you are opposed to applying your energies and ability on work beneath your fullest capacity... if you have Senior or Junior qualifications in electrical or mechanical engineering or physics... send complete resume to

P-5311, Electronics,  
Class Adv. Div., P. O. Box 12, N. Y. 36, N. Y.



ENGINEERS

**PUT YOURSELF IN  
A BETTER POSITION  
TO GET AHEAD**

Make Abbott's your PERSONAL AGENT, and open the door to positions of outstanding reward and satisfaction.

**CHIEF ENGINEER**—motors and generators.

**CHIEF COMPUTER ENGINEER**—programming and data processing.

**CHIEF ENGINEER**—controls-instrumentation.

**SEMI-CONDUCTOR ENGINEERING MANAGER**—advanced development.

**MAGNETRON ENGINEER**—design and development.

**PRODUCTION ENGINEER**—special glass tubes.

**MICROWAVE TUBE SALES ENGINEER**

**SEMI-CONDUCTOR SALES ENGINEER**

Partial Listing

**SALARIES to \$15,000**

Thirty-three years of confidential service, nationally recognized by leading companies as the personnel representative for engineering, scientific and administrative people.

OUR CLIENT COMPANIES WILL ASSUME OUR SERVICE CHARGES. Please send 3 copies of your resume to Mr. George S. Sandel, Director.



EMPLOYMENT SPECIALISTS  
333 Washington Street, Boston 8, Mass.

**RATES . . . . .**

**"Employment Opportunities"**

**Displayed**—The advertising inch is \$25.25 per inch for all advertising appearing on other than a contract basis. Contract rates quoted on request.

An advertising inch is measured 7/8" vertically on a column—3 columns—30 inches to a page.

Subject to Agency Commission.

**Undisplayed**—\$2.40 per line, minimum 3 lines. To figure advance payment count 5 average words as a line.

Discount of 10% if full payment is made in advance for 4 consecutive insertions.

Not subject to Agency Commission.

Send NEW ADS to ELECTRONICS, Class. Adv. Div., P. O. Box 12, New York 36, N. Y., for September Issue Closing August 2nd.

**IT'S A  
Great life  
IN PHOENIX!**

*... and career opportunities at Motorola in Phoenix are second to none!*

Pay is excellent, advancement is rapid, the attitude is friendly and helpful. Other advantages: no commuting problems; nearby colleges that offer advanced study; remarkably low home costs.

And think of the pure pleasure of living in a famed resort area with sunny, dry, shirtsleeve winters... year-round golfing, swimming, picnicking... and seashore and Mexico within a day's drive!

Expanding Phoenix is a vitally important electronics center. Motorola is expanding, too. Grow with Motorola in Phoenix... where it's fun to live!

*Can you fill one of these openings? Write today!*

<p><b>WESTERN MILITARY ELECTRONICS CENTER</b></p> <p>Newest, most complete electronics development laboratories in the country.</p> <p><b>ELECTRONIC ENGINEERS, MECHANICAL ENGINEERS, PHYSICISTS</b></p> <table border="0"> <tr> <td>Transistor Applications</td> <td>Radar Systems Design</td> </tr> <tr> <td>Microwave Techniques</td> <td>Systems Test and Analysis</td> </tr> <tr> <td>Pulse and Video Circuitry</td> <td>R-F and I-F Circuit Design</td> </tr> <tr> <td colspan="2">Servo Mechanisms</td> </tr> </table> <p><i>For above positions write:</i> Mr. William Beardsley Motorola, Inc. - Dept. A-8 Western Military Electronics Center 8201 E. McDowell Road Phoenix, Arizona</p>	Transistor Applications	Radar Systems Design	Microwave Techniques	Systems Test and Analysis	Pulse and Video Circuitry	R-F and I-F Circuit Design	Servo Mechanisms		<p><b>SEMI-CONDUCTOR DIVISION</b></p> <p>A separate division developing, producing and selling semi-conductor devices:</p> <p><b>ELECTRONIC ENGINEERS, MECHANICAL ENGINEERS, CHEMICAL ENGINEERS, PHYSICISTS, METALLURGISTS</b></p> <table border="0"> <tr> <td>Transistor Applications</td> <td>Physical Chemistry</td> </tr> <tr> <td>Transistor Device Development</td> <td>Metallurgical Engineering</td> </tr> <tr> <td>Solid State Physics</td> <td>Production Engineering</td> </tr> </table> <p><b>SALES PERSONNEL</b></p> <p>Field Sales Engineers    Sales Administration</p> <p><i>For above positions write:</i> Mr. Vernon Sorenson Motorola, Inc. - Dept. E-8 5005 E. McDowell Road Phoenix, Arizona</p>	Transistor Applications	Physical Chemistry	Transistor Device Development	Metallurgical Engineering	Solid State Physics	Production Engineering
Transistor Applications	Radar Systems Design														
Microwave Techniques	Systems Test and Analysis														
Pulse and Video Circuitry	R-F and I-F Circuit Design														
Servo Mechanisms															
Transistor Applications	Physical Chemistry														
Transistor Device Development	Metallurgical Engineering														
Solid State Physics	Production Engineering														

Engineering positions also available at Motorola, Inc. in Chicago, Illinois and Riverside, California.

**MOTOROLA, INC.**

## electronic engineers

- DESIGN • DEVELOPMENT
- FIELD ENGINEERING

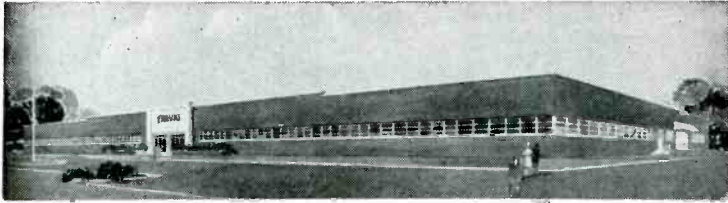

STAVID is engaged in design, development, modification, installation, testing and evaluation of military electronic and electro-mechanical equipment.

STAVID ENGINEERS possess an enviable reputation and are noted for their competence and diversification. You can fulfill your professional ambitions at STAVID.

(New Plant now under construction — 65,000 square feet)

STAVID offers challenging permanent field assignments in New Jersey, the Boston, Mass. area, and other desirable locations throughout the U. S.

Call for interview arrangement or send complete resume to: Personnel Dept.

*Opportunities available in the following fields for those persons with EE or ME degree with minimum of 3 years' experience or equivalent:*

- Fire Control Radar
- Missile Electronics
- Coils, Transformers
- Transistors
- Filter Networks
- Instrumentation
- Microwave
- Servos
- Antennas
- Computers
- Simulators
- Telemetry
- Navigation Systems



## STAVID ENGINEERING, INC.

Route 22, Plainfield, N. J. Plainfield 7-1600

ENGINEERS for GUIDANCE and NAVIGATION SYSTEMS



is the force that overcomes resistance to a solid body or, in the realm of thought, a new idea. At Sanders, it operates irresistibly whenever a new engineering concept encounters outmoded, textbook thinking.

Please address inquiries to D. H. Johnson.



**SANDERS ASSOCIATES, INC.**  
NASHUA NEW HAMPSHIRE

## ARE YOU IN NEED OF ENGINEERS or of HIGHLY TRAINED TECHNICIANS for your Personnel Program?

We offer a free booklet especially prepared to help you solve this problem. It is called the "RESERVOIR of ENGINEERS and TECHNICAL MEN."

This booklet shows, through a listing of the major job titles held by readers of McGraw-Hill Publications, how these men are gathered in convenient, compact groups that you can economically reach with your advertising. Here are no huge, swollen circulations, with expensive price tags where maybe not one reader in a thousand would have the necessary job qualifications.

In a recent advertisement one of the leading aircraft manufacturers restated a well known, but seldom practiced principle:

*A trained, experienced engineer in one specialty can be retrained in almost any other engineering specialty with a minimum of time and effort expended.*

It is one of the purposes of this booklet to show how you can best reach men specifically trained for your needs or technicians who can be easily and quickly retrained.

For your free copy of this booklet write us on your letterhead. You are under no obligation whatsoever. There is a limited supply so write us now.

## McGraw-Hill Publishing Co., Inc.

Classified  
Advertising  
Division

P. O. Box 12  
New York 36, N. Y.



# SENIOR RESEARCH PHYSICIST SENIOR ELECTRONICS ENGINEER

The new Central Research Laboratory of Continental Can Company has several opportunities for versatile scientists and engineers with advanced degrees and industrial experience to pioneer in the application of acoustics, optics, mathematical physics, electronics, rheology, solid state physics, and other fundamental fields to long-range industrial problems in such areas as energy conversion, automatic controls, instrumentation, and communications.

The wide variety of materials manufactured or fabricated at high speeds by Continental includes metals, glass, plastics, paper, fiber, and combinations of these, and provides opportunities for advancing knowledge in many new fields. Research facilities of the Company's new Chicago laboratories are believed second to none, and are located so as to allow staff members to live in some of the finest western and southern suburbs of the city. Proximity to the John Crerar Library, Armour Research Foundation, the University of Chicago, Argonne National Laboratory, and many leading manufacturers of scientific and technical equipment enhances professional development and expedites accomplishment in chosen fields.

Staff members will be granted the full degree of individual recognition attainable in a total staff of 100 covering the fields of chemistry, metallurgy, engineering, and physics, and will have the opportunity to work closely with scientists and engineers in the other fields. Salaries and other benefits meet the highest industrial standards.

Please write, giving a brief resume of qualifications, to Director Physics Research, Central Research and Engineering Division, Continental Can Co, 7622 S. Racine Avenue, Chicago 20, Illinois.

## ENGINEERS

*Find out  
the  
full scope  
of  
opportunities  
in  
Electronics  
at*

Practically any professional interest an electronics engineer may have will find a creative outlet at General Electric's Electronics Park, as you will see by the fields in the coupon on the right. But no mere listing can give you a complete picture of the scope of work at our operation here.

Electronics Park is a birthplace of new concepts and ideas in electronics. Engineers here are continually working on new problems... creating new components, systems, equipment... from which whole new product lines are developed. And as new lines are created, new independent G-E departments are formed. The nucleus of such new departments are often drawn from the development staff at Electronics Park... and the engineer may either follow his "brain-child" or begin anew on the spark of another idea.

Why not check your special professional interest on the coupon and send it to us at Electronics Park. A bachelor's or advanced degree in Electrical or Mechanical Engineering or Physics, and/or experience in electronics is necessary to qualify for current openings here.

**GENERAL  ELECTRIC**

### TO GENERAL ELECTRIC

Electronics Park  
Syracuse, N. Y.

ATT.: Technical Personnel Dept.

### I AM INTERESTED IN

- ... Advanced Development
- ... Design
- ... Field Service
- ... Technical Writing
- ... Sales

### IN THE FIELD OF...

- ... Military Radio & Radar
- ... Multiplex Microwave
- ... Mobile Communications
- ... Semiconductors
- ... Electronic Components
- ... Computers
- ... Tubes
- ... Television Receivers
- ... Industrial Television
- ... Antennae

FROM:

NAME \_\_\_\_\_

ADDRESS \_\_\_\_\_

DEGREE \_\_\_\_\_

8-7-E



## CAREER OPPORTUNITIES

With a company making premium grade electronic equipment for aircraft for almost 30 years. Located in the beautiful lake region of Northern New Jersey, less than 35 miles from New York City.

Navigation Systems

Communication Systems

Servos

Transistors

Transmitters

Receivers

Antennas

- TRANSISTOR CIRCUIT PROJECT ENGINEER
- SERVO AND INSTRUMENT ENGINEERS
- GYRO DESIGN ENGINEER
- TECHNICAL WRITERS
- TRANSMITTER DESIGN ENGINEERS
- CHIEF ENGINEER TO HEAD SERVO AND INSTRUMENT DEPARTMENT

Enjoy the pleasure of working in a new laboratory in a company whose products are known as the highest quality in the industry.

Write or call collect: Personnel Manager

### AIRCRAFT RADIO CORPORATION

Boonton, N. J. DE 4-1800—Ext. 238

## Facts on Careers in Electronics with Otis Elevator Co.

1. The full resources of the 105-year-old Otis Elevator Company are available for expansion of its new Electronic Division.
2. Current prime contracts are on basic development work in the most advanced areas of bombing navigation systems, radar systems and missile launching test equipment. And Otis expects to fully explore the potential for commercial developments as well.
3. This means, to the engineer, ground floor opportunity now . . . with unlimited future in an interesting and rapidly broadening field.

Electronic and Mechanical Engineering Knowledge is required in Servomechanisms, Analog Computers, Pulse & Sweep Generators, Micro-waves

If you are interested in a high level career in electronics . . . with promotions waiting to be earned . . . send your resume now to William B. D Francis. All inquiries in strict confidence.



Electronic Division

OTIS ELEVATOR COMPANY

35 Ryerson St., Brooklyn 5, N. Y.

## Over 400 electronic control circuits

now available  
for quick, easy  
reference

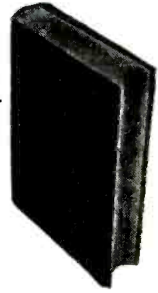

Here are the circuits you need for sorting, timing, measuring, and counting; for sweep control, triggering, temperature and motor control, and hundreds of other industrial uses—each with concise description, performance characteristics, component values, and practical applications. Save hours, even days, of search and preliminary work to find basic circuit ideas for a particular application—consult this big, handy collection of tested circuits—selected from recent issues of *Electronics* and classified and indexed for quick use.

### Handbook of INDUSTRIAL ELECTRONIC CONTROL CIRCUITS

By John MARKUS and Vin ZELUFF  
*Electronics Magazine*  
352 pages, 412 diagrams, \$8.75

Following each description is a reference to the original source where you can get more details on related mechanical problems or study graphs of performance characteristics. In the index, each circuit is cross-indexed as many as a dozen times, to permit locating specific circuits quickly when they are known by a variety of names.

a companion volume . . .

### Handbook of INDUSTRIAL ELECTRONIC CIRCUITS

By Markus and Zeluff

Contains 433 different industrial electronic circuits for immediate practical use. For each circuit there is a clearly-drawn diagram along with a brief yet comprehensive description. 272 pages. 433 diagrams \$7.50.

10 DAYS' FREE TRIAL

McGraw-Hill Book Co., Inc. Dept. FL-8/1/57  
327 W. 41st St., N. Y. 36

Send me book(s) checked below for 10 days' examination on approval. In 10 days I will remit for book(s) I keep, plus few cents for delivery costs, and return unwanted book(s) postpaid. (We pay delivery costs if you remit with this coupon—same return privilege.)

Markus & Zeluff—Indust. Elect. Control Circ.—\$8.75

Markus & Zeluff—Indust. Elect. Circ.—\$7.50

(PRINT)

Name .....

Address .....

City ..... Zone ..... State .....

Company .....

Position .....

For price and terms outside U.S. .... FL-8/1/57  
McGraw-Hill Book Co., Inc.



## project engineers

MECHANICAL, ELECTRICAL OR PHYSICIST

For engineering and development of advanced airborne navigation systems and related test equipment.

## product engineers

1. To supervise test equipment assembly and repair groups.
2. For design of production test equipment for electro-mechanical systems.

In Kollsman you find a company that is small enough to provide quick recognition and reward, yet large enough to assure stability now and in the future. You can take pride in working for the organization which designs America's finest aircraft instruments.

Please send resumes to T. A. DeLuca. Confidential interviews will be arranged.



**kollsman** INSTRUMENT CORPORATION

80-08 45th AVENUE, ELMHURST, NEW YORK • SUBSIDIARY OF Standard COIL PRODUCTS CO. INC.

## SEARCHLIGHT SECTION

(Classified Advertising)

BUSINESS OPPORTUNITIES

EQUIPMENT - USED or RESALE

### DISPLAYED RATE

The advertising rate is \$21.75 per inch for all advertising appearing on other than a contract basis. Contract rates quoted on request. AN ADVERTISING INCH is measured 7/8 inch vertically on one column, 3 columns—30 inches—to a page.

EQUIPMENT WANTED or FOR SALE ADVERTISEMENTS acceptable only in Displayed Style.

### UNDISPLAYED RATE

\$2.40 a line, minimum 3 lines. To figure advance payment count 5 average words as a line.

PROPOSALS, \$2.40 a line an insertion. BOX NUMBERS count as one line additional in undisplayed ads.

DISCOUNT of 10% if full payment is made in advance for four consecutive insertions of undisplayed ads (not including proposals).

REPLIES (Box No.): Address to office nearest you c/o This publication Classified Adv. Div.

NEW YORK: P. O. Box 12 (36)

CHICAGO: 520 N. Michigan Ave. (11)

SAN FRANCISCO: 68 Post St. (4)

### SPECIAL SERVICE

Two graduate engineers with established shop wish to represent manufacturer of electronic or electro-mechanical equipment as service representative in the Boston area. SS-5429, Electronics.

## WANTED

## SALES ENGINEER

with a BS in Electronic Engineering or its equivalent in practical experience to work as applications engineer for leading manufacturer of electronic component parts in the Boston area. Must be capable of working in field and at home office with company representatives and engineering personnel. Short time travelling required. Up to \$10,000.00. Age 25-40. Reply in detail and be prepared to complete a talent survey at our expense. Write

P-5584, Electronics,

Class Adv. Div., P. O. Box 12, N. Y. 36, N. Y.

## ENGINEERING DEGREES

IN E.E.

Major Electronics Under & Postgraduate

May be earned by HOME STUDY or residence work  
5719-G Santa Monica Blvd.  
Hollywood 38, California



## WANTED

(Additional Wanted advertising on page 422)

## CASH PAID!

Sell your surplus electronic tubes. Want unused, clean transmitting, special purpose, receiving, TV types, magnetrons, Klystrons, Broadcast, etc. Also want military & commercial lab test and communications gear. We swap too, for tubes or choice equipment. Send specific details in first letter. For a fair deal write, wire or telephone: WALKER 5-7000

Barry, 512 Broadway, New York 12, N. Y.

## ELECTRONIC ENGINEERS

### LIVE IN THE MIDWEST

Enjoy the advantages of a smaller mid-west city. Give your family a break. Get away from the traffic and rush. Outstanding school system.

Challenging opportunities in design and development work in Audio, TV or High Frequency, AM Broadcast Transmitters, and Communications.

Advancement. Complete benefits. Send details and photo to Personnel Director.

**GATES RADIO COMPANY**  
Quincy, Illinois

## COMMUNICATION ENGINEER

Large Class I Railroad. Unparalleled opportunity for engineer with ideas and initiative to grow with an expanding organization and assume substantial management functions. Report to head of department and assume responsibility for design and specification of system communications, including development of policies, directing activities of subordinate engineers, supervisors and technicians. Graduate to age 40. Experience in VHF and/or microwave radio, plus telephone and carrier practice. RR communication experience desirable. Location Midwest. Salary commensurate with experience. Send resume, transcript of college record, recent photo, and salary requirements with first letter. All replies confidential.

P-5469, Electronics

520 N. Michigan Ave., Chicago 11, Ill.

### WANTED

ART-13/T47A Transmitters .....	\$175.00	BC-348 Rec'r Unmodi- fied Q and R Models	\$50.00
ART-13/T47 Transmitters .....	\$125.00	A R C - I Tranceiver	\$225.00
BC-788C Ait. ....	\$175.00	Complete	
A R C - 3 Transceiver		BC-342 Rec'r .....	\$ 50.00
R5/ARN-7 Radio Compass .....	\$160.00	BC-312 Rec'r .....	\$ 40.00

Ship via Express C.O.D. Subject to Inspection to H. FINNEGAN, 49 Washington Ave. Little Ferry, N.J.

### WILL BUY TUBES

Magnetrons . . . Rectifiers . . . Ruggedized  
Klystrons . . . Regulators . . . 5,000 Series  
Thyratrons . . . Lighthouse . . . Receiving  
Photo Tube . . . Cathode Ray . . . Transmitting

**METRO ELECTRONICS CORP.**  
172 WASHINGTON ST., N.Y. 7, N.Y.  
TELEPHONE BEEKMAN 3-4245



# TUBES

★ NEW ★ NAME BRANDS ★ IMMEDIATE DELIVERY  
★ LOW PRICES ★ UNCONDITIONAL GUARANTEE

1108 Venice Boulevard • Los Angeles 15, California  
Richmond 9-7644  
Cable Address: JASHELEC      Telegraph: FAX

OA2	50.60	3K33	100.00	6BM6	27.50
OA5	3.50	2K33A	50.00	6BM6A	29.00
OB2	.60	2K34	85.00	6C21	15.00
OB2WA	2.50	2K41	100.00	6D4	1.50
OC3/VR105	.50	2K42	110.00	6J4	1.25
OD3	.50	2K43	100.00	6J4WA	2.00
1AD4	1.00	2K44	110.00	6J5WGT	2.00
ELC1B	1.00	2K45	30.00	6J6W	.85
CIK/B	7.50	2K46	175.00	6K4	2.00
1B22	1.10	2K47	75.00	6L6WGA	3.50
1B23	2.00	2K48	50.00	6L6WGB	3.00
1B24	5.00	2K50	125.00	6L6Y	2.00
1B24A	12.50	2K54	5.00	6SK7W	.85
1B25	1.25	2K56	50.00	6SU7GT	2.00
1B26	1.25	2X2A	.75	6V6GT	1.00
1B27	10.00	3AP1	1.25	6X4W	1.00
1B29	2.50	3B22	1.45	6X4WA	2.00
1B32	1.00	3E24	.75	6X5W	1.00
1B35	3.25	3B24W	4.50	6X5WGT	1.25
1B36	3.75	3B24WA	7.50	7UP7	20.00
1B37	6.00	3B26	2.75	7Y2P	75.00
1B40	3.00	3B29	5.50	5RC-12	150.00
1B42	12.00	3C22	57.50	12AT7WA	2.75
1B44	16.50	3C23	3.25	12AY7	1.75
1B45	22.50	3C31	1.00	12DP7	15.00
1B47	4.00	3C33	6.00	12GP7	15.00
1B51	6.75	3C45	5.00	12SP7B	25.00
1B58	60.00	3DP1-52	5.00	X-13	150.00
1B62	4.00	3DP11A	6.00	BL-15	Q
1B63A	16.50	3DP21A	3.90	BL-16	Q
1N21B	1.00	3E29	8.00	PJ22	Q
1N23B	.80	3FP7A	2.50	HK24	3.00
1N23BM	2.50	3JP1	7.50	26A7GT	3.00
1N25	2.00	3J30	25.00	26E6WG	2.50
1N26	1.00	3J31	3.50	26D7W	2.00
1N28	6.00	3K22	150.00	RK29D	Q
1N31	1.75	3K23	150.00	VR33	30.00
1N32	9.00	3K30	95.00	D-42	40.00
1N38A	.60	3W5000A3	95.00	RK47	3.00
1N40	4.75	4-65A	13.50	V-50	75.00
1N42	8.00	4-125A	19.00	V-50R	75.00
1N46	.40	4A1	2.00	HK-54	2.00
1N52	.65	4B23	4.00	QK-57	Q
1N63	1.40	4B26	7.50	QK-59	20.00
1N69	.40	4C28	19.75	QK-60	20.00
1P21	30.00	4D21	19.50	RK-60/1641	1.25
1P22	5.00	4E27	7.00	QK-61	20.00
1P24	1.50	4J22	35.00	RK-61	2.50
1P25	45.00	4J26-30	50.00	QK-62	20.00
1P28	7.50	4J32	45.00	HY-65	1.00
1P30	1.35	4J34	25.00	HY-69	2.25
1Q22	40.00	4J42	25.00	RKR-72	5.00
1W5	.75	4J50	95.00	RKR-73	.50
1Z2	2.50	4J52	50.00	FG-95	14.00
2AP1	2.00	4J63	40.00	WE101D	3.00
2A515	4.50	4J64	40.00	WE101F	3.00
2B91	3.75	4R60A	3.75	FG-105	11.00
2B22	1.90	4X150A	18.00	FG-123A	2.50
2B24	.80	4X150D	25.00	FG-128A	7.00
2C33	.75	4X250M	35.00	FG-154	10.00
2C36/846B	25.00	5ABP1	20.00	VT158	9.75
2C39A	10.00	5ADP1	20.00	FG-166	6.75
2C40	6.00	5B	1.00	FG-172	15.00
2C42	8.50	5BP2A	2.95	QK172	200.00
2C43	8.00	5BDP7	25.00	FG178	10.00
2C46	5.00	5CP1	1.95	QK-181	12.50
2C50	6.00	5CP1A	7.50	HF-200	10.00
2C51	3.05	5CP2	6.00	WL-200	50.00
2C52	2.25	5CP7A	8.00	QK202	165.00
2C53	9.75	5CP11A	9.50	203A	2.50
2D21W	.80	5C22	20.00	204A	25.00
2D29	.80	5JP1	8.00	205F	6.00
2E22	2.50	5JP1A	22.50	207	75.00
2E24	2.50	5JP2	5.00	211/VT4C	4.00
2E25	3.75	5JP4	3.50	212E	15.00
2E27	.60	5JP5	6.50	WL-218	15.00
2E32	1.00	5JP11A	7.50	CEP220	4.00
2E41	1.50	5LP1A	20.00	QK221	150.00
2H21	49.50	5MP1	2.95	RX231A	75
2J31	12.25	5NP1	2.00	QK-243	40.00
2J32	10.00	5R4G	1.25	QK246	200.00
2J34	10.00	5R4WA	4.00	QK249	150.00
2J36	29.50	5R4WG	2.50	WE245A	6.00
2J39	25.00	5SP1	45.00	249B	2.50
2J48	25.00	5SP7	40.00	249C	2.50
2J49	35.00	5Y3WGT	1.40	250-R	4.50
2J50	35.00	5Y3WGTA	3.75	250TH	21.00
2J51	150.00	5ZP16	60.00	250-TL	12.50
2J54	25.00	6C1	12.00	250R	3.50
2J55	50.00	6AC7A	.75	WE-251A	45.00
2J56	40.00	6AC7W	.75	WE-252A	7.50
2J61	12.50	6AK5W	1.00	QK253	150.00
2J61A	40.00	6ANS	2.25	X-481D	2.25
2J62	4.00	6ANSWA	4.75	FG-254A	75.00
2J62A	40.00	6AR6	1.35	WE-258B	5.00
2K22	13.50	6AS6W/5725	2.70	259A	10.00
2K23	12.50	6AS7G	2.50	V-260/VA6310	75.00
2K25	10.00	6AU6WA	2.25	527	75.00
2K26	32.50	6BL6	24.00	FP265	18.00
				WE-269A	6.00

FG-271	22.00	CUE578	8.50	927	.75	5829	.85
271A	5.00	579B	Q	935	4.00	5829WA	3.75
WE-274B	.75	583	2.00	957	.95	5837	50.00
FG-280	27.50	KU-610	3.50	958A	.35	5840	3.00
WE-282A	2.00	KU-627	7.50	959	1.15	5840A	4.50
WE-282B	4.00	KU-628	7.50	991	.35	5841	4.25
WE283A	3.25	WL-652	20.00	CK-1005	.35	5842/417A	12.00
QK283A	150.00	HK-654	17.50	CK-1006	2.25	5844	1.50
		GL-672	20.00	CK-1007	4.45	5847/404A	12.00
		Q WE-701A	1.50	K1253P7	29.50	5851	3.50
		WE-703A	1.25	HY1269	3.25	5852/TE5	6.00
		WE-704A	.60	1603	3.50	5853	60.00
		WE-705A	.75	1614	1.50	5855	35.00
		705AY-GY	10.00	1620	3.75	5876	5.00
		707B	2.00	1622	2.00	5879	1.25
		WE-708A	.75	1623	1.25	5893	9.00
		WE-709A	1.50	1624	1.15	5896	3.00
		714A	7.50	1625	.30	5899	3.50
		715A	1.75	1626	.25	5902	4.00
		715B	2.50	1631	1.00	5902A	5.50
		715C	10.00	1636	.75	5902A (CL)	2.50
		717A	.50	1641	1.35	5903	12.50
		720AY-EY	35.00	1945	65.00	5904	8.50
		721A	.50	2000T	150.00	5905	7.75
		721B	7.00	2050	1.00	5906	8.50
		722A	.75	2051	.65	5907	8.50
		723A/B	7.00	HK3054	100.00	5910	.50
		725A	2.50	ZB3200	75.00	5915	.50
		726A	4.25	4210	Q	5916	8.50
		726B	10.00	R-4330	9.00	5932	3.25
		726C	10.00	RK4340	9.00	5933/807W	1.25
		730A	7.50	5116	5.00	5948/175A	150.00
				5117	1.00	5956	35.00
				5531	200.00	5962/BS101	4.00
				5544	15.00	5964	.80
				5545	25.00	5965	1.00
				5551/FG271	25.00	5967	10.00
				5553/FG258A	75.00	5977A	3.00
				5559/FG57	8.00	5981	50.00
				5560/FG95	14.00	5982	149.50
				5561/FG104	29.50	5987	9.50
				5586	110.00	5992	9.00
				5588	75.00	5993/TE-10	5.00
				5606	125.00	6005/6AQ5W	1.70
				5611	40.00	6019	300.00
				5634	5.00	6021	3.00
				5636	2.50	6021-A	4.50
				5639	5.00	6029/408A	2.00
				5639A	6.00	6037/QK243	49.00
				5641	4.50	6038	7.50
				5643	4.00	6046	.75
				5644	5.75	CK-6050	2.00
				5645	5.00	6073	1.50
				5646	3.75	6074	3.00
				5647	4.00	6080	3.50
				5647A	10.00	6080WA	6.00
				5650/5981	50.00	6081/ATR407	22.50
				5651	1.25	6082	3.00
				5652	1.25	6088	3.00
				5654/6AK5W/6096	3.00	6095	2.00
				5656	4.00	6096	1.30
				5657	100.00	6097	1.50
				5663	.95	6099	1.40
				5665	35.00	6100/6C4WA	2.00
				5667	100.00	6102/6J6WA	2.25
				5670	1.00	6106	9.00
				5670A	4.25	6110	5.50
				5672	1.25	6111	4.00
				5676	.75	6112	4.50
				5683	1.25	6116	90.00
				5686	1.10	6117	60.00
				5687	1.25	6130	5.00
				5687A	2.25	6134	3.50
				5693	4.25	6136	2.50
				5696A	5.00	6147	3.00
				5703	1.25	6159	3.00
				5702WA	4.25	6161	42.50
				5703	.85	6169	Q
				5703A	4.00	6177	75.00
				5704	1.25	6184	9.00
				5718	1.75	6186/6AG5WA	2.25
				5719A	2.00	6189/12AU7WA	3.00
				5721	1.30	6197	1.25
				5725/6AS6W	2.75	6199	27.50
				5725/6AS6W/6187	4.00	6201/12AT7WA	3.00
				5726/6ALS	.70	6203	2.75
				5726/6ALS/6097	3.00	6205	4.50
				5727/2D21W	1.25	6211	1.00
				5749/6BA6W	1.00	6263	10.00
				5750	2.25	6264	10.00
				5751	2.00	VA-6310/V260	75.00
				5751WA	3.50	6329	20.00
				5755/420A	6.50	6363	75.00
				5763	1.00	6406/QK428	200.00



## COMMUNICATIONS EQUIPMENT CO.

## PULSE TRANSFORMERS

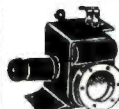
 352-7150. Primary 50 ohms. Secondary 1000 ohms, 12,000V, 12.0 Amp. Pulse: 1 or 2 usec. at .001 duty ratio. Fitted with magnetron well and bifilar winding for filament supply. \$22.50

**MAGNETRON PULSE TRANS. #964:** Prim. imp. 30 ohms, 1600 v. pulse. Secondary imp. is 1250 ohms, 12 KV pulse. Turns ratio sec:pri. is 7.5:1. Duty ratio is 0.001 at 1.2 usec. Bifilar winding 1.2A. \$8.50

**RAYTHEON WX 4298E:** Primary 4KV., 1.0 USEC. SEC. 16K-16 AMP DUTY RATIO: 001 400 CYCLE PUL. TRANS. "BUILT-IN" \$17.50

**GE #K-2499A:** Primary: 9.33 KV, 50 ohms imp. Secondary: 28 KV, 450 ohms. Pulse length: 1.05/5 usec @ 635/120 PPS. PK Power Out: 1,740 KW Bifilar: 1.5 amps \$62.50

**GE #K-2748-A:** 0.5 usec @ 2000 Pps. Pk. Pwr. out is 32 KW impedance 40:100 ohm output. Pri. volts 2.3 KV Pk. Sec. volts 11.5 KV Pk. Bifilar rated at 1.3 Amp. Fitted with magnetron well. \$24.50

**K-2745:** Primary: 3½.8 KV. 50 ohms Z Secondary: 14/12.6 KV 1025 ohms Z. Pulse length: 0.25/1.0 usec @ 600/600 PPS. Pk. Power 200/150 KW. Bifilar: 1-3 Amp. Has "built-in" magnetron well. \$32.50 (All Primaries 115V. 400 Cycles)

## 400 CYCLE TRANSFORMERS

(All Primaries 115V. 400 Cycles)

RA6405-1	800VCT/65MA, 5VCT/3A	\$3.69
T-48852	700VCT/806MA, 5V/3A, 6V/1.75A	4.25
352-7098	2500V/6MA, 300VTC/135MA	5.95
K-59336	110V/50MA, TAPPED 625V 2.5V/5A	3.95
M-7474319	6.3V/2.7A, 6.3V/66A, 6.3VTC/21A	4.25
KS80984	27V/4.3A, 6.3V/2.9A, 1.25V/.02A	2.95
52C080	650VCT/50MA, 6.3VCT/2A, 5VCT/2A	3.75
32332	400VCT/35MA, 6.4V/2.5A, 6.4V/1.5A	3.95
68G631	1150-0-1150V 2MA	2.75
80G198	6VCT/0.0006 KVA	1.75
302433A	6.3V/9.1A, 6.3VCT/6.5A, 2.5V/3.5A, 2.5/3.5A	4.85
KS9445	592VCT/118MA, 6.3V/8.1A, 5V/2A	5.39
KS9685	6.4V/5A, 6.4V/3.6A, 6.4/2.5A	4.79
M7474318	2100V/027A	4.95
70G30G1	600VCT/56MA	2.65
352-7069	2-2.5V Wdgs at 2.5A, Each Lo-Cap., 22Kv Test	5.95
352-7096	2.5V/1.79A, 5V/1.3A, 6.5V/6A, 6.5V/3A, D/D B800	4.95
352-7099	360VCT/20MA, 1500V/1MA, 2.5V/1.75A, 6.3V/2.5A, 6.3V/6A, P/O VC929	6.45

MICROWAVE PLUMBING  
X-BAND—RG, 52/U WAVE GUIDE

**PARABOLOID DISH, 18" diam.** Spun Aluminum 8" Focus. For AN/APS-6 \$4.50

**3 CM. DIPOLE and Feed Assembly** (May be used with above dish.) 8 inches long. \$5.00

**FLEXIBLE SECTION** 9 in. long. Cover-to-Cover \$5.50

**ROTARY JOINT (A/S-6)** Sperry PT #658275, 180 deg. rotation, choke to choke. Has "Built-in" Di-Coupler. 20 DB, with "N" Takeoff. \$17.50

**3 CM. DIPOLE FEED, 15" L** for APS-15. \$14.50

**MITRED ELBOW, Cast aluminum, 1¼" x ¾" W.G. W. E. Flanges, "E" Plane.** \$3.50

**3 CM. ANTENNA ASSEMBLY:** Uses 17" paraboloid dish, operating from 24 vdc motor. Beam pattern: 5 deg. in both Azimuth and elevation. Sector Scan: over 160 deg. at 35 scans per minute. Elevation Scan: over 2 deg. Tilt. Over 24 deg. \$35.00

**Cross-Guide Directional Coupler, UG-40** output flange. Main Guide is 6" Long, with 90 Deg. "E" Plane bend at one end, and is fitted with Std. UG 39/UG 40 flanges. Coupling figure: 20 db Nominal. \$22.50

**Bulkhead Feed-thru Assembly.** \$12.00

**Pressure Gauge Section** with 15 lb. gauge. \$10.00

**Directional Coupler, UG 40/U take off 20db.** \$15.00

**MAGNET AND STABILIZER CAVITY** For 2J41 Magnetron. \$24.50

**90 degree elbows, "E" Plane 2½" radius.** \$8.50

**Beacon/receiver unit, Complete** with dual klystron mount, TR/ATR section, duplexer, and 30 mc IF/Mixer unit. Originally designed for 9000 mc receiving using 723A/B. New, less tubes. \$22.50

**Klystron mount for 723A/B.** Front end of microwave receiver (SO-3), with balanced mixer crystal mt. and iris coupling for AFC. less tube. \$15.00

## 10 CM.—RG48/U Waveguide

**Waveguide to Coax, adapter.** Matches RG48/U. waveguide to RG 44/U rigid coax. Complete with flanges, "V" match. \$15.00

**10CM ECHO BOX:** Tunable from 3200-3333 Mc. For checking out radar transmitters, for spectrum analysis, etc. Complete with pickup antenna and coupling devices \$17.50

**POWER SPLITTER** for use with type 726 or any 10 CM Shepherd Klystron. Energy is fed from Klystron antenna through dual pick-up system to 2 type "N" connectors. \$12.50

**LHTR. LIGHTHOUSE ASSEMBLY.** Parts of RT39 APG 5 & APG 15. Receiver and Trans. Cavities w/ assoc. Tr. Cavity and Type N CPIO. To Recv. Uses 2C40, 2C43, 1B27, Tunable APX 2400-2700 MCS. Silver Plated. \$15.00

**McNally Klystron cavity** for 2K28 or 707H, tunes 2700-2910 mc. Complete with tuning vanes. \$5.00

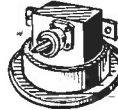

## 3000 MC WAVEMETER

Mfd. by G.E. for Armed Services 3000-3700 MC. Comes furnished with variable attenuator, coax adapter cord, Cal. chart and pickup antenna. Has output jack for external meter or other monitor device. Resonance indicator is 3½ 20 microamp meter. Brand new, in portable wooden carrying case. \$75.00



## TEST EQUIPMENT

**TS 102 Radar Range calibrator.** Rep. rates are 400/800/1600/2000 PPS. Operates from 115, 60-1600 cy. Used, exc. \$95.00

**RCA WR 39A TV Calibrator.** 20-240mc. with crystal on 2.5 or .25 mc. Used, exc. \$65.00

**RCA WR 53A. F M Sweep Generator** covers 88-108 mc and 8.5-10.7 mc. \$49.00

**108 mc and 8.5-10.7 mc.** \$49.00

**RCA WR 67A. Test oscillator.** 100kc-30 mc. internal or external mod. \$43.00

**RCA 710A Signal Generator.** 380-560 mc. \$70.00

**Kay Marka-Sweep, Model RF-P.** TV alignment generator, channels 1-12, plus LF freq. Markers at pix and audio. Output 0.5v across 70 ohms. \$125.00

**P4E Synchroscope.** 4 mc. bandwidth with a gain of 100. 5-inch display, includes 2-stage video amplifier. Writing speeds 0.04/0.166/0.5/2 in. per microsec. \$75.00

**TS/28/UPM Synchroscope.** Uses 5CP1 tube, and may be used as a regular scope with repetitive sweeps. Signal gain is 100 with a bandwidth of 5mc. Triggered sweeps range from 1 to 6 microsec. per inch. \$135.00

## PULSE EQUIPMENT

**MIT. MOD. 3 HARD TUBE PULSER:** Output Pulse Power 144 KW (12 KV at 12 Amp). Duty Ratio: .001 max. Pulse duration: 0.5, 1.0, 2.0 microsec. Input voltage: 115 v. 400 to 2400 cps. Uses: 1-715B, 1-82911, 3-72's, 1-73. New. Complete with pressurized housing. \$135

## 10 CM R.F. HEAD

**Complete R.F. Head and Modulator** delivers 50 K.W. Peak R.F. at 3000 MC. Pulser delivers 12KV pulse at 12 Amp. to magnetron of .5, 1 or 2 microsec. duration at duty cycle of .001. Unit requires 115V. 400-2400 Cycles, 1 phase @ 8.5A. Also 24-28 VDC @ 2A. External sync. Pulse of 120 V. Reqd. Brand New. Complete with magnetron, magnet, plumbing and all tubes. \$275

343 Canal St., New York 13, N.Y. Dept. E-8 Chas. Rosen Phone: Canal 6-4882

# GOVERNMENT ELECTRONICS BULLETIN!

## From Disposal Office, Dayton Air Force Depot, Dayton, Ohio

More and more electronics equipment is being received daily at Dayton Air Force Depot. This means that the selection for you, the bidder, is getting better and better.

**THE COMPLETE SYSTEM SALES POLICY** is shortly going into effect. This is important to you, the buyer of electronic equipment! YOU WILL BE ABLE TO PURCHASE COMPLETE SYSTEMS WHENEVER POSSIBLE. As in the past, you may also purchase the separate component parts.

**For Example: SCR-274N Radio Set**, composed of the following components: Ant. Relay Unit BC-442, 3 Dynamotors DM-32-A, 1 Dynamotor DM-33-A, 1 Modulator Control Unit BC-456-A, 1 Radio Control Box BC-451-A, 1 ea. Radio Receivers BC-453-A, BC-454-A, BC-455-A, and 3 transmitters, BC-457-A, BC-458-A, BC-459-A, plus Racks and Tubes.

**NOTE:** this SCR-274N is used here only as an illustration of the new sales policy for future sales. When such equipment is available as a complete system, you will be notified by means of "Invitations to Bid" forms, which are mailed out over our bidders list. For complete bidding details, refer to our ad on page 423 of the April 1, 1957 issue of ELECTRONICS.

We are now processing equipment for a large October Sale. Bidders list will receive notification of exact dates.

IF YOU ARE NOT ALREADY ON THE BIDDER'S LIST, WRITE NOW

DISPOSAL AGENT (MDSPM)  
DAYTON AIR FORCE DEPOT

BOX 1659  
GENTILE AIR FORCE STATION  
DAYTON 10, OHIO

**SAVE UP TO 70%  
OF  
WHOLESALE COST**

**ALL COMPONENTS  
1ST QUALITY AND  
100% GUARANTEED**

**WE INVITE YOUR  
INQUIRIES FOR ALL YOUR  
ELECTRONIC NEEDS**

**FROM ONE OF THE  
LARGEST INVENTORIES  
IN THE U.S.A.**

**SYNCHROS**

COMPLETE LINE OF COMMERCIAL ARMY AND NAVY TYPES

1CT	\$37.50	5N	\$22.50
1DG	37.50	5SDG	12.50
1HCT	42.50	5SF	29.50
1F	37.50	5SG	29.50
1G	37.50	6G	34.50
3D	62.50	6DG	27.50
3HCT	62.50	6HG	42.50
5B	22.50	7G	42.50
5CT	34.50	7DG	42.50
5HCT	42.50	23CX6	45.00
5F	34.50	21H1	4.95
5G	34.50	21G1	3.95

MANY OTHER TYPES IN STOCK QUOTATIONS ON REQUEST

**POLYSTYRENE CAPACITORS**  
1% Tolerance

Hermetically Sealed 200VDCW-500VDC  
0.5 MFD. \$7.50 Ea.  
1 MFD. \$12.10 Ea.  
MFD by Western Electric... Brand New

**IMMEDIATE  
DELIVERY**

**TEFLON and KEL-F  
INSULATED HOOK-UP WIRE**  
in Stock for Immediate Delivery  
VARIOUS COLORS and SIZES  
Inquire For Complete Listing  
At Money Saving Prices

**TYPE "J" POTENTIOMETERS**  
2 Watt Carbon

Full Range of Values Available From Stock for Immediate Delivery  
Single Type J Units..... \$ .95 Ea.  
Dual Type JJ Units..... 2.95 Ea.  
Triple Type JJJ Units..... \$3.95 Ea.  
SEND FOR COMPLETE LISTING

**FREQUENCY METER**

125KC to 20 MC—Heterodyne Freq. Meter—Crystal Calibrated—Accur.—.02% to 2MC; .01% from 2-20 MC—Modulated—Battery Oper.—w/Calibration Books—Exc. Cond.—checked out—Gtd. Ea. \$79.50

**MEGGER**

Winslow 50-1000—Insulation Resistance Test Set—Range 0-1000 Megohms at 500VDC—complete with Leads & Carrying Case Brand New—\$129.50

**HEWLETT-PACKARD**

**WAVE GUIDE TEST EQUIP'T.**

G-370B Fixed Attenuator 1" x 2"	\$45.00
—8DB	
G-370D Fixed Attenuator—1" x 2"	45.00
—20DB	
J-370C Fixed Attenuator 3/4" x 1 1/2"	45.00
—10DB	
J-370D Fixed Attenuator 3/4" x 1 1/2"	45.00
—20DB	
S-370D Fixed Attenuator 1 1/2" x 3"	52.50
—6DB	
S-370D Fixed Attenuator 1 1/2" x 3"	52.50
—20DB	
G-870A Slide Screw Tuner 1" x 2"	95.00
3.95 to 5.85 KMC.	
J-870A Slide Screw Tuner 3/4" x 1 1/2"	95.00
5.85 to 8.20 KMC.	
AC-24 WAVE GUIDE STAND	2.50
S-25 Wave Guide Clamp 3/4" x 1 1/2"	1.25
G-25 Wave Guide Clamp 2" x 1"	1.25

**KOLLSMAN SERVO MOTORS  
WITH TACH GENERATOR**

TYPE 890-0160-40-MOTOR-115V-60 Cy. 2Ph. 3350 RPM-5 Watts Output. GEN. 6.5V/2000 RPM—\$59.50 Ea.  
TYPE 1623B-0410120-Motor-25V-400 Cy.-2Ph. 6500 RPM-.045 Watts Output GEN. 0.34V/1000 RPM \$42.50 Ea.

Terms: 20% cash with order, bal. C.O.D. unless rated. All prices net F.O.B. our warehouse Phila., Pa., subject to change without notice.  
Special Discounts on Quantity Purchases

**TEST EQUIPMENT**

**GENERAL RADIO**

GR 106M-1 Hy. Std. Inductance	\$32.00
GR 107N—Variable Inductor	\$50.00
GR 219K Decade Condenser	\$110.00
GR 419A Wavemeter 20-300 Mc.	\$75.00
GR 434B Audio Freq. Meter	\$95.00
GR 475-B82 Frequency Monitor AND	\$300.00
GR 681-A82 Frequency Dev. Meter	\$71.50
GR 713B Beat Freq. Osc.	7.50
GR 820A Het. Freq. Meter	\$345.00
GR 700P1 Voltage Divider	27.50
GR 715A DC Amplifier	250.00
GR 720A Het. Freq. Meter	275.00
GR 723C VT Fork ILC	\$89.50
GR 724B Precision Wavemeter	180.00
GR 728A V.I.V.M.	\$65.00
GR 727A V.T.V.M. (Battery Oper)	\$105.00
GR 814-P2 Filter	\$15.00
GR 820A Low Pass Filter	\$20.00
GR 1110A Freq. Standard with	\$475.00
GR 1110P1 Multivibrator	\$170.00
GR 1170A Freq. Meter 25-60 000 cy.	\$170.00
GR 1838B Contractor	\$75.00
GR 1861A Megohmmeter	\$180.00
Boonton 207A Inverter	\$180.00
Boonton 110A QX Checker	\$185.00
Boonton 152A EM Signal Gen. 20-28	\$57.50
MC & J-5 MC W/150R Pwr Supply	\$89.50
Dumont 185 Electronic Switch	\$375.00
Dumont 208 Oscilloscope	
Dumont 248 Oscilloscope	
Esterline Angus-20 Pen Operation Re-	320.00
border Portable type	
Hewlett-Packard 423B Distortion Ana-	\$220.00
lyzer	
Hewlett-Packard 3371F FM Monitor	\$465.00
25-175 MC.	
Kay Megawatt 50KC-1000MC	\$200.00
Lawrie Lm-239A Oscilloscope	\$80.00
Measurements 62 V.T.V.M.	99.50
Measurements 78E Std. Signal Gen.	115.00
80-75 KC.	165.00
Measurements 70B Pulse Gen.	85.00
Rubicon 1168 Resis. Std. .001 ohms	150.00
Serry Microline Model 291A Cavity	
Freq. Meter 2575-3780 MC—Accur.	\$395.00
0.1% MC.	

**TEST EQUIPMENT**

Victoreen *247 AV Radiation Survey	\$1115.00
Meter 0-2.5/25/250 milliroent-	
gens/hr.	
Weston Model I Direct Reading Ohm-	120.00
star 0-2.5/25/50 ohms 1/4 %	
Weston 45 DC Voltmeter 0-15V-1/4	\$35.00
Acc.	30.00
Weston 695 Power Level Meter	\$50.00
Weston 785 Industrial Circuit Tester	\$42.00
Weston 796 Megohmmeter 0-20/200	
megohms 500V. Battery Operated.	
AN/UPM-2 Wavemeter 40-1220 Mc	\$97.50
Accur. 1 MC.	9.95
AT-48/UP-3 GM Pickup Horn Antenna	12.95
AT-105/AP/K Bard Pick-up Horn Ant.	\$115.00
BC-231 Frequency Meter 125 KC-	
90 000 KC—Accur. .05%	
I-126 Signal Generator 15-25 MC &	115.00
I-195-225 MC-Int. Mod.	\$125.00
I-138A 100MC Signal Generator 2700-	
2900 MC	
LAE-1 UHF Signal Generator 510-	\$225.00
1300 MC Accur. 1%	
LAF VHF Signal Generator 90-600	\$325.00
MC. Accur. 1%	
LHA Audio Oscillator 20-20,000 cy.	\$85.00
Mfd. by Hewlett-Packard	
LF Std. Signal Generator 9.5 KC-50	\$375.00
MC-2V. Output	\$60.00
ME-114/U. R.F. Wattmeter	
TS-32/AP 3 CM Frequency Meter	\$145.00
3700-9500 MC Accur. .03%	
TS-34/AP Oscilloscope 30cps-1 Mc	\$195.00
Portable	
TS-46/AP Wave Meter 3000 MC.	49.50
TS-100/AP Oscilloscope-A. J. R. & X	
Indiation-Freq. video to 3 MC.	89.00
TS-174/U Freq. Meter 20-230 MC	385.00
Accur. .05%	
TS-311A/UP/Precision Echo Box 3730	
to 500 MC—Measures frequency,	
power, spectrum analysis. Incl.	\$225.00
Crystal mixer tester.	
STODDART TS-587/U Noise and	1200.00
Field Intensity Meter 15-400 MC	
TS-588A/U Std. Signal Generator	
3 KC-50MC 2V. output	390.00

Note—All items new except where noted\* Excellent Used—Checked out & Guaranteed

**WRITE FOR  
A COMPLETE  
LIST OF SURPLUS  
EQUIPMENT**

**ELECTRONIC  
RESEARCH LABORATORIES**

715-19 Arch St., Phila. 6, Pa. \* Market 7-6771  
Cable Address: ELECTRONIC, Philadelphia

**CALVERT  
ELECTRONICS,  
INC.**

**TUBES**

Over one million tubes in stock

RCA • KEN-RAD • SYLVANIA • CBS • WESTINGHOUSE • W.E.

Type	Price	Type	Price	Type	Price	Type	Price	Type	Price	Type	Price
OA2	.65	2J33	20.00	5BP4	2.50	28D7	1.00	21E	17.50	QK389	15.00
OB2	.50	2J34	15.00	5B21	1.25	FG32	3.50	215A W.E.	2.00	394A	2.75
OC3	.50	2J38	10.00	5C22	17.50	RK34	.50	217C	1.75	402A W.E.	12.50
OD3	.45	2J49	25.00	5CP7	2.50	L040CT	2.00	220B	90.00	404A W.E.	12.50
1B26	1.00	2K26	35.00	5D21	5.00	UH50	5.00	221A	100.00	416B W.E.	Q
1B32	.25	2K28	24.00	5D23	10.00	HK54	4.00	222A W.E.	100.00	417A W.E.	12.50
1B35	3.25	2K37	100.00	5D24	15.00	Q1C59	100.00	249B	2.65	429A W.E.	6.00
1B38	25.00	2K48	45.00	5J22	5.00	RK59	1.25	253A W.E.	2.00	421A W.E.	3.75
1B62	2.75	2K56	50.00	5MP1	2.75	RK60	1.25	254A W.E.	2.50	422A W.E.	7.50
1L24	18.00	2X2	.15	5R4WG	2.50	QK61	20.00	259B W.E.	5.00	429A	12.00
1L33	22.00	EL-3C	3.45	5SP7	45.00	RK72	.25	262B W.E.	5.00	446B	1.00
1N21	.25	3A5	.50	5SP11	45.00	RK73	.25	267B W.E.	5.50	464A	2.00
1N22	.50	3B27	3.25	5Y3WGT	1.50	CV88	2.00	274A W.E.	2.50	WL468	12.50
1N23	.50	3C37	20.00	6AC7W	1.00	101D W.E.	2.50	285A W.E.	5.00	H500	35.00
1N23B	.90	3CP1	2.50	6AJ5	1.25	101F W.E.	2.50	304TH	10.00	CK502AX	1.00
1N38A	.50	3CP151	2.00	65N7WGT	1.25	VU1115	.75	304TL	10.00	CK503AX	1.00
1N43	.25	3DP152A	7.50	65L7WGT	1.25	114B	.50	310A W.E.	3.75	CK505AX	1.25
1N70	1.00	3D21A	3.00	7AC19	100.00	RX-120	20.00	323A	7.50	CK506AX	1.00
1P23	1.75	3E29	8.45	7BP7	3.75	V-123A	6.75	332A	25.00	CK507AX	1.25
1P41	2.50	3FP7A	2.50	7C29	65.00	VT-127	2.50	348A W.E.	4.75	CK522AX	1.25
1P42	5.00	3GP1	2.00	7MP7	7.50	F127A	15.00	350B W.E.	2.00	WL532A	.25
2C22	.35	3HP14	1.75	9CP7	10.00	F-128A	7.50	356B W.E.	3.00	705A W.E.	.65
2C26	.25	3J21	50.00	12DP7	10.00	GL-152	10.00	359A W.E.	1.75	706AY	15.00
2C26A	.35	3J27	3.45	12DP7A	20.00	FG-154	10.00	368A W.E.	2.00	707B	2.50
2C27	5.00	3KP1	7.50	12SP11	45.00	203A	2.00	374A W.E.	1.75	713A	.25
2C33	.50	4AP10	4.50	12SP11	45.00	204A	25.00	375A W.E.	10.00	715A	2.00
2C34	.25	4-125A	23.00	RX21A	9.00	AV209	5.00	387A W.E.	3.75	717A	.35
2C40	6.50	4-250A	33.00								
2C43	10.00	4B22/EL5B	3.75								
2C46	5.00	4J25	25.00								
2C53	10.00	4J26	25.00								
2E22	2.75	4J27	25.00								
2E24	2.25	4J29	50.00								
2E25	2.50	4J30	40.00								
2E25A	2.85	4J31	100.00								
2E36	1.35	4J33	75.00								
2J21	2.50	4J51	35.00								
2J22	2.50	4PR60A	25.00								
2J29	50.00	4X150A	20.00								
2J31	10.00	5AP1	2.75								

Type	Price	Type	Price
718CY	25.00	1631	1.00
720BY	35.00	1632	.20
721A	.75	1680	1.00
722A	.75	1846	50.00
723AB	8.50	5517	1.25
724B	.50	5517	1.25
725A	5.00	5518	275.00
730A	5.00	5528/C6L	5.00
801A	.25	5637	5.00
803	2.00	5650	50.00
805	4.50	5651	1.25
806	7.50	5651	1.25
811	2.65	5676	.75
813	9.50	5693	4.50
829B	8.45	5703	.90
832A	7.75	5718	1.50
836	1.25	5719	1.50
838	.29	5726	.75
841	.29	5726	.75
843	.35	5744	1.00
845	4.00	5803	3.75
851	6.50	5814	1.00
861	10.00	5825	6.25
872A	1.00	5827X	5.00
876	.75	5838	5.00
884	1.00	5933	1.50
891	55.00	6035	10.00
955	.25	6038	5.00
991	.30	6073	1.75
K-1001	50.00	6098CT	2.00
Dumont	50.00	6099	1.00
K-1051	50.00	6130	4.75
Dumont	50.00	8008	3.00
1616	.35	8012	1.00
1619	.25	8013A	3.50
1625	.25	9002	.50
1626	.25	9002	.50
1629	.15	D178461 W.E.	75.00

Partial list, many additional types in stock, write for our catalog.  
Export Facilities.

**CALVERT ELECTRONICS, Inc.**

Cable Address: Calverton, N. Y. Telephone CA. 6-7400  
DEPT. S, 536 BROADWAY NEW YORK 12, N. Y., U. S. A.



# ELECTRONIC

WAR TERMINATION INVENTORIES

WRITE OR WIRE FOR INFORMATION ON OUR COMPLETE LINE OF SURPLUS ELECTRONIC COMPONENTS. ALL PRICES NET F.O.B. PASADENA, CALIFORNIA

# C&H SALES CO.

2176-E East Colorado St.  
Pasadena 8, California  
RYan 1-7393

## INVERTERS

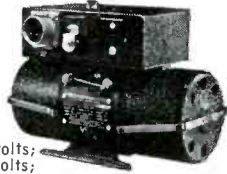

- 10042-1-A Bendix  
DC Input 14 volts;  
output: 115 volts;  
400 cycles. 1-phase; 50 watt **\$35.00**
- 12116-2-A Bendix  
Output: 115 VAC; 400 cyc; single phase; .45 amp. Input: 24 VDC, 5 amps. **\$35.00**
- 12117 Bendix  
Output: 6 volts; 400 cycles, 6 volt amperes, 1 phase. Input: 24 VDC; 1 amp. **\$15.00**
- 12121 Bendix  
Input: 24 volt D.C. 18 amp. 12000 r.p.m.  
Output: 115 volts, 400 cycle, 3-phase, 250 volt amp, 7 pf. **\$49.50**
- 12123 Bendix  
Output: 115 V; 3 phase; 400 cycle; amps. .5; Input: 24 VDC; 12 amp. **\$49.50**
- 12126-2-A Bendix  
Output: 26 volts; 3 phase; 400 cycle; 10 VA; 6 PF. Input: 27.5 volts DC; 1.25 amps. **\$24.50**
- 12130-3-B Bendix  
Output: 125.5 VAC; 1.5 amps. 400 cycles single phase, 141 VA. Input: 20-30 VDC. 18-12 amps. Voltage and frequency regulated. **\$49.50**
- 12137 Bendix  
Output 250 VA, 115 volts, 3 phase, 400 cycle, 1.25 amp., 0.8 pf. Input 27.5 volt DC, 20 amp. **\$59.50**
- 12142-1-A Bendix  
Output: 115 volts, 3 phase, 400 cycle, 250 VA. Input: 27.5 VDC, 22 amps. Voltage and frequency regulated. **\$99.50**
- 12147-1 Pioneer  
Output: 115 VAC, 400 cycles; single phase. Input: 24-30 VDC; 8 amps. **Price \$39.50 each**
- 778 Bendix  
Output: 115 volt, 400 cycle; 190 VA; single phase and 26 volt, 400 cycle, 60 VA, single phase. Input: 24 VDC. **\$37.50**
- 10285 Leland  
Output: 115 volts AC; 750 VA, 3 phase, 400 cycle, .90 pf and 26 volts. 50 VA single phase, 400 cycle, .40 pf. Input: 27.5 VDC 60 amps. cont. duty, 6000 rpm. Voltage and frequency regulated. **\$59.50**
- 10339 Leland  
Output: 115 volts; 190 VA; single phase; 400 cycle, .90 pf and 26 volts; 60 VA; 400 cycle, .40 pf. Input: 27.5 volts DC, 18 amps. cont. duty, voltage and freq. regulated. **\$49.50**
- 10486 Leland  
Output: 115 VAC; 400 cycles; 3-phase; 175 VA; .80 pf. Input: 27.5 DC; 12.5 amps.; cont. duty. **\$70.00**
- 10563 Leland  
Output: 115 VAC; 400 cycle; 3-phase; 115 VA; 75 pf. Input: 28.5 VAC; 12 amps. **\$35.00**
- PE109 Leland  
Output: 115 VAC, 400 cyc.; single phase; 1.53 amp.; 8000 rpm. Input: 13.5 VDC; 29 amp. **\$50.00**
- PE218 Leland  
Output: 115 VAC; single phase pf. 90; 380/500 cycle; 1500 VA. Input: 25-28 VDC; 92 amps.; 8000 rmps.; Exc. Volts 27.5. BRAND NEW **\$30.00**
- MG149F Holtzer-Cabot  
Output: 26 VAC @ 250 VA; 115 V. @ 500 VA; single phase; 400 cycle. Input: 24 VDC @ .36 amps. **\$40.00**
- MG153 Holtzer-Cabot  
Input: 24 VDC; 52 amps. Output: 115 volts —400 cycles, 3-phase, 750 VA. Voltage and frequency regulated. **\$95.00**
- DMF2506M Continental Electric  
24-30 volts input; 5.5-45 amps.; cont. duty. Output: 115 volts; .44 amps.; 400 cyc.; 1 phase; pf. 1.0; 50 watts. **\$39.50**
- AN 3499 Eicor, Class "A"  
Input: 27.5 volts at 9.2 amps. AC. Output: 115 volts, 400 cycles; 3 phase, 100 voltamp; continuous duty. **Price \$39.50 each**

## POTTER & BRUMFIELD RELAY

#SM515 SPDT 8,000 ohm 11/16" dia. x 1 11/16" long. Approx. weight 1 oz. Hermetically sealed. Standard 7-pin miniature base.

Price **\$3.00** each

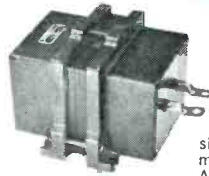

## S14940 TRANSFORMER

Mfgd. by Kenyon. Output: 5 volts, 115 amps. Input: 105/125 volts, 60 cycle, single phase. Overall dimensions: 10" x 7" x 6". Approx. weight: 30 lbs. **\$15.00**

## SELSYNS-SYNCHROS



- ICT Cont. Trans. 90/55V 60 cy. **\$37.50**
- IDG Diff. Gen. 90/90V 60 cy. **37.50**
- IF Sym. Mtr. 115/90V 60 cy. **37.50**
- IG Gen. 115V 60 cy. **37.50**
- ISF Svn. Mtr. 115/90V 400 cy. **12.50**
- 2J1F1 Gen. 115/57.5V 400 cy. **7.50**
- 2J1F3 Gen. 115/57.5V 400 cy. **10.00**
- 2J1FA Gen. 115/57.5V 400 cy. **7.50**
- 2J1G1 57.5/57.5V 400 cy. **5.00**
- 2J1H1 Diff. Gen. 57 5V 400 cy. **7.50**
- 2J5D1 Cont. Trans. 105/55V 60 cy. **17.50**
- 2J5F1 Cont. Trans. 105/55V 60 cy. **17.50**
- 2J5H1 Gen. 115/105V 60 cy. **17.50**
- 2J15M1 Gen. 115/57.5V 400 cy. **17.50**
- 5CT Cont. Trans. 90/55V 60 cy. **34.50**
- 5D DiF. Mtr. 90/90V 60 cy. **34.50**
- 50DG Diff. Gen. 90/90V 60 cy. **34.50**
- 5F Syn. Mtr. 115/90VAC 60 cy. **34.50**
- 5G Sym. Gen. 115/90VAC 60 cy. **34.50**
- 5HCT Cont. Trans. 90/55V 60 cy. **42.50**
- 5SDG Diff. Gen. 90/90V 60 cy. **12.50**
- 6DG Diff. Gen. 90/90V 60 cy. **25.00**
- 6G Sym. Gen. 115/90VAC 60 cy. **34.50**
- 7G Sym. Gen. 115/90VAC 60 cy. **42.50**
- R110-2A Kearfott Cont. Mtr. 115V 400 cy. **17.50**
- R200-F Kearfott Cont. Trans. 26/ 1.8V 400 cy. **15.00**
- R210-1-A Kearfott Trans. 26/ 1 8V 400 cy. **20.00**
- R220-T-A Kearfott Receiver 26/ 1.8V 400 cy. **20.00**
- R235-1A Kearfott Resolver 26/ 1 8V 400 cy. **22.50**
- C5670 Type 11-4 Rep. 115V 60 cy. **20.00**
- C69405-2 Type 1-1 Transm. 115V 60 cy. **20.00**
- C69406 Syn. Transm. 115V 60 cy. **20.00**
- C69406-1 Type 11-2 Rep. 115V 60 cy. **20.00**
- C76166 Volt. Rec. 115V 60 cy. **10.00**
- C78248 Syn. Transm. 115V 60 cy. **12.50**
- C78249 Syn. Diff. 115V 60 cy. **5.00**
- C78863 Repeater 115V 60 cy. **7.50**
- C7933 Transm. Type 1-4 115V 60 cy. **20.00**
- 851 Bendix Autosyn Mtr. 22V 60 cy. **7.50**
- 403 Kellsman Autosyn. Mtr. 32V 60 cy. **7.50**
- FPE-25-11 Diehl Servo Mfr. 75/ 15V 60 cy. **19.50**
- FPE-43-1 Resolver 400 cy. **25.00**
- FJE-43-9 Resolver 115V 400 cy. **19.50**
- 999-0411 Kollsman 26V 400 cy. **15.00**
- 13770410 Kollsman 26V 400 cy. **10.00**
- 1515B-0410 Kollsman 26V 400 cy. **20.00**
- 10047-2A Bendix 26V 400 cy. **12.50**
- 2900 Transicoil 115V 400 cy. **15.00**
- 15CX4a Synchro Transmitter MK 22 /MOD 1 **15.00 ea.**

## INFRA-RED RECEIVER

(SNOOPERSCOPE) TYPE A1

Contains elaborate optical system with many-coated lenses. Unit is very lightweight complete with carrying case. Receiver is 8 1/2" long with 2 1/2" Schmidt Ultra high speed approximately +0.5 object lens.



**\$19.95 ea.**

## DIFFERENTIAL



Size 2-11/16" long 1-11/16" dia. 1-1 reverse ratio. 1/4" shaft on each end; one shaft 25/32" long, one shaft 15/32" long. Input and output gear 1-23/32" dia. 53 teeth.

**\$3.50 ea.**

Stock No. 150

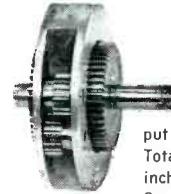

## SIMPLE DIFFERENTIAL

1 to 1 reverse ratio; 48 teeth on input and output gear, 1-1/32 inch diameter. Total outside diameter 1-25/32 inches. Shaft size is 1/4 inch. One shaft is 9/16" long; other shaft is 3/16" long. **\$5.00**

Stock No. 151

## 3800 CYCLE INVERTER

Mfgd. by Eclipse-Pioneer #12144-1-A. Input: 24-30 volts DC, 10 amps AC. Output: 115 volts, .95 amps, 3800 cycle, single phase. Approx. weight 2 1/2 lbs. **Priced at \$39.95**

Forward & Reverse 2 1/4-0-2 1/4. Input shaft spline gear 12 teeth 9/32" dia. 3/8" long. Output shaft 15/64" dia. x 15/32" long. Control shaft 11/32" x 3/8" long. Cast aluminum construction. Approx. size 3" x 3" x 2 3/4".



**No. 145 \$17.50 ea.**

(All Shafts on Both Ball Bearing Supported)

## SMALL DC MOTORS



(approx. size overall 3 3/4" x 1 1/4" dia.)

- 5067126 Delco PM, 27 VDC, 125 RPM, Governor Controlled **\$15.00 ea.**
- 5069600 Delco PM 27.5 VDC 250 rpm **12.50**
- 5069230 Delco PM 27.5 VDC 145 rpm **15.00**
- 5068750 Delco 27.5 VDC 160 rpm w. brake **6.50**
- 5068571 Delco PM 27.5 VDC 10,000 rpm (1x1x2") **5.00**
- 5069790 Delco PM, 27 VDC, 100 RPM, Governor Controlled **15.00 ea.**
- 5BA10A118 GE 24 VDC 110 rpm **10.00**
- 5BA10AJ37 GE 27 VDC 250 rpm reversible **10.00**
- 5BA10AJ52 27 VDC 145 rpm reversible **12.50**
- 5BA10AJ50, G.E., 12 VDC, 140 R.P.M. **15.00**
- 206-1001 PM Planetary Gear Reduced. Motor with Magnetic Brake. Mfgd. by Air Equipment 26 volts 600 ma 145 rpm **17.50**
- 5BA10FJ33, G.E., 12 VDC, 56 R.P.M., reversible **15.00**
- 806069 Oster series reversible 1/50 h.p. 10,000 rpm. 27.5 VDC 1 5/8" x 3 1/2" **5.00**
- C-28P-1A 27 VDC 1/100 h.p. 7,000 rpm **3.00**
- 7100-B-PM Hansen 24 VDC 160 rpm **7.50**
- SSFD-6-1 Diehl PM 27.5 VDC 10,000 rpm **4.00**
- 6-volt PM motor mfgd. by Hansen 5,000 rpm 1 1/4" in dia., 2" long overall **4.00**

**RADAR**

**P.P.I. REMOTE REPEATERS**

VD-7" Upright  
VE-7" Table Type  
VF-5" "B" Scope "5" P.P.I.  
VG-24" Plotting Table  
VJ-12" Upright  
VK-12" Upright  
VL-12" Upright R.H.I. IND.  
All indicators are 110v 60 eye.

**AN/APR-4**

**38-4000 MC RECEIVER**



**RDO**

**NAVY SEARCH RECEIVER**

The RDO is a very elaborate radar search receiver greatly improved over the APR-4. The set uses APR-4 tuning units, but is much more versatile, having input metering, D.B. output meter, automatic noise limiter and greater selectivity and sensitivity. The RDO is recommended when only the very best will do. Input 110v 60 eye.



**AN/ASQ-1 AIRBORNE MAGNETOMETER**

This is an airborne chart recording magnetometer. The set consists of an amplifier, oscillator, detector head, chart profile recorder, power supply. The equipment has a sensitivity of 2 gamma. The AN/ASQ-1 records on an Esterline angus recorder disturbance in the earth's magnetic field. An indicator is provided that gives a bearing on a magnetic disturbance. Input is 28v DC. Weight about 130 lbs.

**SHORAN**

**AN/APN-3-AN/CPN-2**

The AN/APN-3 and AN-CPN-2 are Precision distance measuring installations. This equipment operates on 225 mc. The range is 250 miles with an accuracy of 25 feet. This equipment is widely used by geological companies for prospecting and mapping. Power input is 110v 400eye and 28v DC.

**RADALAB INC.**

87-17 124th St., Richmond Hill 18, New York, N. Y.

Phone Virginia 9-8181-2-3

OVERSEAS CUSTOMERS CALL US DIRECTLY BY TELEX OVERSEAS TELETYPE TWX N. Y. \*4-4361

**AN/GSQ-1 SPEECH SCRAMBLER**

This is a unit designed to be attached to either a radio or telephone circuit to scramble speech or code. This equipment utilizes coded cards in each terminal equipment. Unless the properly numbered card is inserted on the receiving end the speech can not be unscrambled. This provides an excellent privacy system. 24 VDC input. Mfg. Western Electric.

**COUNTER MEASURES EQUIPMENT**

**SEARCH DETECTION**

AN/APR-4 38-4000 MC  
AN/APR-2 300-1000 MC  
AN/APR-5 1000-3100 MC  
AN/APR-6 1,000-10,000 MC

**DIRECTION FINDING**

AN/APA-17 300-10,000 MC  
AN/APA-24 100-750 MC  
AN/APA-48 140-300 MC

**PANORAMIC AND PULSE ANALYZING**

AN/APA-6 Pulse Analyzing  
AN/APA-11 Pulse Analyzing  
AN/APA-10 Panadaptor  
AN/AP-1-38 Panadaptor  
AN/APQ-5 18-80 MC Receiver Indicator  
AN/APQ-8 25-105 MC Barrage Rec-Trans Indicator  
AN/ARQ-10 1.5 MC-50 MC Receiver-Trans. Jammer Indicator  
AN/ARQ-1 Thru 12 also avail.  
AN/APA-23 Signal and Time Recorder

**NOISE GENERATORS**

AN/URA-T1  
AN/URA-2T  
MD-4/URA  
Shot-Noise, Bagpipes, Tone, Random Keying, Output. These units will key any transmitter.

**JAMMER TRANSMITTERS**

AN/APT-1 Thru 10 25-3,000 MC  
AN/APQ-1 thru 20  
AN/SPT-Series  
SCR-596 1.5-30 MC Barrage Rec.-Trans.  
TDY, MRQ, SPT, SPQ-TPQ-1AN/UPT-T1-T3, T4  
Many other countermeasures equipments avail, both hi and low power. These equipments can be used to test new radar and computer systems for susceptibility to jamming and other countermeasures. We can supply complete setups covering any freq. from 100 KC-10,000 MC, with power supplies for mobile operation.

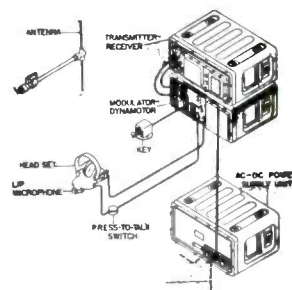

**MAR POINT TO POINT RADIO SET**

Portable 225-398 mc point to point 10 chan. crystal controlled voice and new radio set. This is a very late radio set used for point to point and ground to air communication. The transmitter output is 8 watts on 10 pre-set crystal controlled channels instantly selected by a band switch. The RFC is also crys. controlled on the trans. freq. The set is inclosed in 3 water proof shock proof cabinets that may be set up in a few minutes on location. This equipment is ideal where a reliable radio link easily transported is needed. Power input is either 24 VDC 115/230V AC or DC. Complete sets avail. Write

**GROUND INSTRUMENT LANDING SYSTEM**

This set consists of an AN/GRN-10 localizer and a AN/GRN-2 glide path ground station. This equipment can be set up at an airport to provide a complete I.L.S. that will operate with the AN/ARN-5 and RC-103 airborne I.L.S. system to provide blind approach facilities. This system can be installed permanently or transported. Each station has complete monitoring facility. Input power is 110V 60 eye.

**AN/TRC-1-3-4**

100 MC RADIO-RELAY EQUIPMENT  
The AN/TRC series is a mobile portable set for duplex or simplex radio telephone point to point communication. This set will operate with the CF series carrier systems to provide multi channel operation. The TRC operates on 100 MC with an output of 10-50 watts. The set is crystal controlled. Complete sets avail. Input 110v 60 eye.

**SCR-399-499**

Mobile and fixed station high power radio sets: the SCR-399 is mounted in a HO-17 shelter. The SCR-499 is transported in carrying cases to be set up for field operation. Freq. of the sets is 2-18 mc. pwr output is 350w. Phone and C.W. 2 communication receivers are provided. Input is 110v 60 eye.

for the sweetest buys in the book

**TRY CANDEE!**

Here is part of our current inventory—ready to ship!

ARC-1 Transceiver R-268B Recvr.  
ART-13 Transmitter ARC-27 Transcvr.  
BC-348Q Recvr. & Parts  
RSA/ARN7 APS-15

**TEST EQUIPMENT**  
Hewlett-Packard 624-B Test Set  
APR-4 TEST SET. Complete with all tuning units. Spare tuning units also available.

TS-175/U BC-221 LM FREQ.  
TS-173/U TS-34A METER

**DOMESTIC AND FOREIGN BUYERS:**  
Write today regarding your current needs. We have been selling since 1945 and can save you money. Prompt action assured.

**J. J. CANDEE CO.**  
Dept. E.  
4002 W. Burbank Blvd. Burbank, Cal.  
PHONE: Victoria 9-2411

SQUARE D ALLEN BRADLEY

KURM BUTLER HAMMER  
STEVEN HAMMER ALLIED  
ARNO GENERAL ELECTRIC  
WESTO CLARE  
PHILLI SIGMA  
CONTR OOMATIC  
DORME ELECTRIC  
WESTER LEACH  
ELECTR RUTHERS  
AMPERT DUNN  
POTTER NORTH  
BRUMFIE ELECTRIC  
LEDEX ADVANCE  
GUARD ELECTRIC  
WARD LEONARD

**LARGEST STOCK OF RELAYS IN THE WORLD**

Send for our latest bulletin

**Universal RELAY CORP.**  
Formerly Universal General Corp.

42 WHITE ST., NEW YORK 13, N. Y. • WALKER 5-9642

Save your money!  
Don't buy anything till you get our ...

**NEW FREE SALES BULLETIN!**

It is loaded with bargains in ALL departments

Tubes Test Equip.  
Meters Mikes  
Headsets Transmitters  
Receivers Capacitors  
Transformers Etc., etc., etc.,

SEND FOR BULLETIN TODAY!  
You'll be glad you did!

**ARROW SALES, INC. Dept. E.**  
7460 Varna Ave. No. Hollywood, Cal.

PREMIUM QUALITY  
**SILICON RECTIFIERS**  
BOGUE TYPE IN318  
Rated 250 ma, 200 piv, at 100 C.  
New, Prime, Surplus  
Priced far below original cost:  
1-9 @ \$2. 10-99 @ \$1.75,  
100 or more @ \$1.40 each

M. Conrad 7208 Germantown Ave.  
CH-8 2700 Philadelphia 19, Pa.



## AN/APT-5 TRANSMITTERS

Make excellent power signal generators for the range 300-1625MC., rated at 58 watts CW RF at 500MC. Contains blower-cooled 3C22 in re-entrant cavity with precision cathode, plate and loading controls, plus 6 tube AM MODULATOR and amplifier flat from 50KC to 3MC. (easily converted to audio) with phototube noise generator. 115 volt 60 cycle filament supply. New, in export packing, with matching special plugs, lecher line, alternate feedback assembly, manual, audio conversion instructions and technical data, at \$250.00. Limited stock.

## AN/APR-4 RECEIVERS

With all five Tuning Units covering 38 to 4,000MC; versatile, accurate and compact, the aristocrat of lab receivers in this range. Complete with wideband disccone antenna, wavetraps, 100 page manual, plugs, cables and mobile accessories as required.

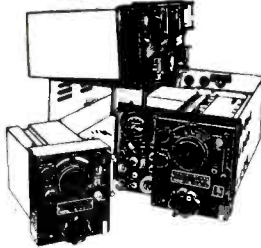

The AN/APR-4 has been our specialty for over ten years. Over 40 hours of laboratory time is invested in each complete set immediately prior to shipment, so that we can not only guarantee it to pass A-N specifications, but to have the inevitable mass-production irregularities corrected and the latest improvements added. We maintain a complete stock of spare parts and expect to service our customers' sets indefinitely. Write for data sheet and quotation.

## TEST EQUIPMENT

Of highest quality, new and reconditioned, military surplus and top commercial brands in stock at money-saving prices. Let us quote to your requirements.

## ENGINEERING ASSOCIATES

434 Patterson Road Dayton 9, Ohio

## NEED METERS? STANDARD or SPECIALS

ANY QUANTITY—NEW—MILITARY

FOR ELECTRONIC—MILITARY  
AIRCRAFT—HAMS

ALL MAKES—MODELS  
RANGES—SIZES

METERS REPAIRED  
RESCALED  
RECALIBRATED

WRITE - PHONE - WIRE

## INSTRUMENT SERVICE

76-14 Woodside Ave.

Elmhurst 73, N. Y.

CAA No. 4264 Ltd. HA 9-2925

# SPECIAL PURPOSE TUBES

OA2	.60	4C27	7.00	FP-54	50.00	723A/B	6.00	5886	1.75
OA2WA	2.50	4C33	100.00	HK-54	2.00	725A	2.25	5887	2.25
OA3/VR-75	.90	4C35	14.00	VX-55	4.00	726A	4.00	5687WA	4.00
OA4G	.75	4D32	23.00	FG-57	7.50	726B	9.50	5691	4.25
OA5	3.50	4E27	7.00	RK-61	2.25	726C	7.50	5692	4.50
OB2	.60	4J45	35.00	RK-65/5D23	6.50	750TL	30.00	5693	3.75
OB2WA	2.50	4J46	35.00	FG-67	7.50	802	2.00	5702	1.40
OB3/VR-90	.80	4J52	50.00	HY-69	2.00	804	7.00	5703	.85
OC3/VR-105	.50	4J61	125.00	FG-81A	8.50	805	3.00	5704	1.15
OC3W	2.50	4PR60A	27.50	FG-95	14.00	807	1.10	5719	1.35
OD3/VR-150	.50	4X150A	17.50	100TH	5.00	807W	1.25	5720	15.00
OD3W	2.50	4X500F	42.50	102L	2.50	807WA	5.00	5725	2.00
EL-C1A	6.00	5A6	2.00	121A	2.50	810	10.00	5726	.75
1AD4	.90	5AP1	5.00	122A	2.50	811	3.00	5727	1.25
1AE4	1.00	EL-5B	4.00	123A	2.50	812	2.50	5728	7.50
1AF4	2.50	5BP1	2.50	124A	2.50	813	10.00	5734	12.00
1AG5	2.00	5BP1A	7.50	VT-127A	2.00	814	1.25	5740	50.00
1B24	5.00	5BP2A	3.00	FG-172	15.00	815	1.25	5749	1.15
1B35	3.25	5C22	25.00	FG-190	10.00	816	1.35	5750	2.00
1B35A	7.50	5CP1	2.00	CE-203	5.00	826	.75	5751	2.00
1B63A	15.00	5CP1A	7.50	203A	2.50	828	8.00	5755	6.50
1B83	7.50	5CP7A	8.00	CE-235A	5.00	829B	8.50	5763	1.00
1P21	29.50	5CP12	10.00	FG-235A	55.00	832A	4.85	5771	250.00
1P22	5.00	5FP14	5.00	242C	10.00	835	2.50	5783	3.50
1P25	25.00	5HP1A	7.50	QK-243	40.00	836	1.20	5784	4.50
1P28	7.50	5JP1	7.50	244A	5.00	837	1.25	5787WA	6.00
1Y2	5.00	5JP2A	5.00	245A	6.00	845	2.50	5796	10.00
2AC15	4.50	5JP4	3.50	249B	3.00	850	7.50	5798	15.00
2AP1	2.00	5JP5A	7.50	249C	2.50	866A	1.15	5801	5.00
2AP1A	4.00	5JP11A	7.50	250R	4.00	866 JR	1.35	5803	5.00
2AS15	4.50	5LP1	12.50	251A	42.50	868/PJ-23	1.50	5814	.75
2BP1	3.00	5LP2A	7.50	252A	7.50	869B	50.00	5814A	1.50
2C36	35.00	5R4GY	1.25	253A	2.00	872A	1.00	5814WA	3.00
2C39	5.00	5R4WGY	2.25	254A	2.25	874	.75	5819	25.00
2C39A	10.00	5RP1A	17.50	257A	10.00	884	.95	5827	4.00
2C39B	29.00	5RP11A	75.00	FG-258A	75.00	885	.65	5828	6.00
2C40	6.50	5S1	40.00	259A	10.00	913	17.50	5829	.85
2C40A	26.00	5SP7	40.00	262B	5.00	917	1.40	5830	85.00
2C42	8.00	5UP7	12.50	FP-265	15.00	918	1.50	5836	93.00
2C43	7.50	5X3	2.00	267B	3.50	920	2.00	5840	3.00
2C44	.25	5XP1	50.00	268A	5.00	922	1.75	5842	12.00
2C46	5.00	5XP11	50.00	271A	5.00	923	1.25	5847	12.00
2C50	6.00	EL-C6J	10.00	272A	6.00	927	1.00	5854	.85
2C52	2.75	EL-C6L	5.00	274B	5.00	929	1.00	5876	5.00
2D21	.75	6AC7W	.50	275A	3.50	931A	4.00	5881	3.00
2D21W	.85	6W-6AK5	1.25	276A	10.00	959	1.15	5886	2.75
2E22	2.00	6AK5W	1.00	279A	150.00	CK-1006	2.25	5894	15.00
2E24	2.00	6ALSW	.75	282A	2.00	1237	4.50	5899	3.50
2E26	3.25	6AN5	2.25	282B	3.75	HY-1269	3.00	5902	4.00
2J47	50.00	6AQ5W	1.75	283A	3.25	1274	2.50	5902A	5.00
2J51	150.00	6AR6	1.35	285A	4.50	1619	.50	5915	.50
2J52	50.00	6AR6WA	6.00	286A	3.25	1620	3.50	5932	3.25
2J54	25.00	6AS6	1.25	287A	2.00	1624	1.10	5933	1.25
2J59	50.00	6AS6W	2.00	293A	8.00	1846	50.00	5933WA	5.00
2J61	8.50	6AS7G	2.50	300B	6.00	2050	1.00	5948/1754	100.00
2J62	3.00	6AU6WA	2.00	304TH	10.00	2050W	3.00	5949/1907	75.00
2J64	75.00	6BA6W	1.25	304TL	12.50	ZB-3200	75.00	5962	4.00
2K25	10.00	6BE6W	2.00	310A	3.50	5528	5.00	5963	1.25
2K26	32.50	6BL6	22.50	311A	3.50	5550	30.00	5964	.85
2K28	30.00	6C4W	4.00	313C	2.50	5552	55.00	5975	3.00
2K29	30.00	6C21	15.00	316A	.50	5553	75.00	5977	2.50
2K30	75.00	6F4	2.25	323A	7.50	5556	10.00	5979	7.50
2K33A	50.00	6J4	1.25	323B	5.00	5557	4.00	5980	6.50
2K34	100.00	6J4WA	2.00	328A	3.50	5558	5.50	5981/5650	50.00
2K35	150.00	6J6W	.85	336A	3.50	5559	7.50	5998	4.50
2K41	85.00	6K4	2.00	338A	3.50	5560	14.00	6005	1.75
2K45	30.00	6K4A	2.50	339A	9.50	5584	3.00	6012	3.50
2K48	50.00	6L4	2.00	347A	2.50	5591	2.75	6021A	4.00
2V3G	.85	6L6WGA	3.25	350A	2.50	5610	1.00	6028	2.00
3ABP1	50.00	6L6WGB	3.50	350B	2.00	5633	5.00	6037	50.00
3AP1	2.00	6Q5G	2.25	352A	15.00	5634	5.00	6038	7.50
3AP11A	5.00	6S17WGT	2.00	354A	8.50	5635	5.00	6073	1.25
3B24	.75	6SK7W	.85	355A	8.50	5636	2.50	6080	3.50
3B24W	4.50	6SK7WA	2.00	388A	1.00	5636A	3.00	6087	4.00
3B24WA	7.50	6SL7WGT	1.25	393A	3.50	5637	3.50	6098	6.00
3B25	3.50	6SN7WGT	.75	394A	2.50	5638	3.00	6100	2.00
3B26	2.75	6SU7GTY	2.00	403A	1.35	5639	5.00	6130	5.00
3B28	4.00	6X4WA	2.00	403B	2.75	5639A	6.00	6134	3.50
3B29	5.00	6X5WGT	1.00	404A	12.00	5640	5.00	6136	2.00
3BP1	2.00	7FMP7	1.50	407A	3.00	5641	4.50	6137	2.00
EL-3C	4.00	7MP7	15.00	408A	2.00	5642	.90	6146	4.40
EL-C3JA	10.00	VX-10	4.00	409A	4.25	5643	4.00	6189	2.50
3C23	3.00	12AT7WA	2.75	417A	12.00	5644	5.75	6199	27.50
3C24	2.00	12AU7WA	2.50	418A	15.00	5645	5.00	6201	2.85
3C33	6.00	12DP7A	25.00	420A	6.50	5646	3.00	6236	185.00
3C45	5.00	FG-17	4.00	421A	4.50	5647	4.00	6263	10.00
3D22	9.50	HK-24	2.00	429A	8.00	5650	50.00	6264	10.00
3E22	4.00	HK-24G	2.00	446A	.50	5651	1.25	6322	8.50
3E29	10.00	26A7GT	3.00	446B	1.00	5651WA	3.00	6328	4.85
3GP1	2.00	26C6	1.10	450TH	38.50	5654	1.25	6626	2.50
3J21	50.00	26D6	1.50	450TL	38.50	5656	4.00	6627	2.50
3J31	35.00	26Z5W	2.25	464A	1.75	5663	.95	6655	35.00
3JP1	7.50	26Z5W	3.00	575A	10.00	5667	100.00	8005	4.50
3JP7	10.00	FG-27A	10.00	631-P1	5.00	5670	2.00	8012A	3.50
3JP12	10.00	FG-32	5.50	701A	1.50	5670WA	4.00	8013A	4.50
3KP1	7.50	FG-33	15.00	707B	2.00	5672	1.00	8020	1.25
3X2500A3	150.00	BX-33A	5.00	715C	10.00	5675	6.85	9001	.50
4-65A	13.50	35T	3.00	719A	10.00	5676	.75	9002	.50
4B31	20.00	35TG	2.50	721A	.50	5678	.75	9003	1.00
4B32	7.50	VX-41	5.00	721B	7.50	5685	10.00	9005	2.00

ALL TUBES ARE NEW, INDIVIDUALLY CARTONED, FULLY GUARANTEED

## western engineers

ELK GROVE, CALIFORNIA  
SUPPLIERS OF TUBES SINCE 1932

Prices are F O B  
shipping point

Orders for less than  
\$10 cannot be  
processed

**SUBMINIATURE RELAYS HERMETICALLY-SEALED**



**'DIAMOND H' Relays**  
Mfg. By  
**HART MANUFACTURING CO.**  
The "Diamond H" series R Hermetically sealed Relays will match or surpass USAF Spec. MIL-R-5757B.  
26.5 V.D.C. Coil Res. 150 ohms  
4PDT (4C) Contacts rated 2A @ 30 V.D.C.  
Hart #R115BIP-1 Plug-In type  
Dim. 1-1/16" dia. x 1 3/4" High. R115BIP-1 **\$1.75**

Hermetically Sealed

15 Pin SOCKET for above Relay. R101PS Each 25¢



Fig. 1 Fig. 2 Fig. 3

**STRUTHERS-DUNN RELAYS**

4PST Norm. open (4A) 28v. D.C. Coil 280 ohm. Will operate on 18v. D.C. Hermetically Sealed. Size 2 1/2" x 1 1/2" x 2 3/4". Contacts 10 amp. at 30v. D.C. or 115v. A.C. non-ind.



Struthers-Dunn  
#182DXX107  
**\$1.75**

**STRUTHERS-DUNN Sub-Miniature RELAYS**

Size 1 1/4" dia. X 1 1/4" high. Mounting centers 1 3/8" except fig. #3 3/8" mtg. Studs. 26.5 V.D.C. 150 ohms.

Fig. 1 Dunco #220XCX310 3PDT (3C) R103  
Fig. 2 Dunco #220XDX310 4PDT (4C) R104  
Fig. 3 Dunco #220XDX301 4PDT (4C) R105

Net each **\$1.75**

**K1097-P19 (7ACP-19) THREE BEAM CATHODE RAY TUBE**

The Type 7ACP19 is a 6 3/4" diagonal, rectangular face, three beam, post accelerator, electrostatic deflection and focus Cathode Ray Tube. Each beam is independently controlled except for Heater, Cathode and Accelerating voltages. The Deflection Electrodes of each beam are electrostatically shielded from each other. The Gun Structures are designed so as to give no appreciable Focus Voltage Current.



K1097-P19 (7ACP-19)

**SPECIAL PRICE \$35.00**

Special Discounts on Quantity Purchases. Production Quantities Write for Engineering Data Bulletin

**C & B ELECTRONICS • 1949 W. ERIE ST. • CHICAGO 22, ILL. • TA. 9-8580**

**DUMONT HIGH VOLTAGE POWER SUPPLIES**

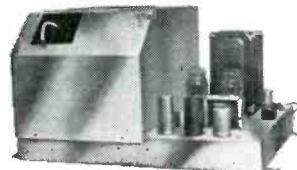

Delivers 23 kv. fully regulated and adjustable

- RADAR
- SNOOPERSCOPIES
- COLOR AND PROJECTION TV
- HIGH VOLTAGE TESTING, ETC.

Made by Dumont for RA119, 30 inch TV. Pulse Type H.V. generator and voltage-doubler with 8 tube voltage-regulator. Contains sweep protection circuits to disable the H.V. upon sweep failures. Low voltage also regulated by use of Sola Power Transformer with matching capacitor (cost over \$30). Contains 13 tubes and 3 relays. Input 117 V. AC 60 cycles. Schematic diagram included. Original cost over \$150.

NEW ..... **\$49.95 ea F.O.B. BROOKLYN**

**WE HAVE LARGE QUANTITIES:**

2AF4A	5639	5899	6101
6J4	5718	5902	6111
6J4 WA	5719	5977	6112
6J6 WA	5840	6021	

**WE NEED:**

- R-30-U
- W.E. 187 A
- W.E. 251 A
- W.E. 111 C
- W.E. 94 E
- 2X13
- 2X7
- Ear Phones
- Capacitors
- Retard Coils
- Inductors
- Resist Coils
- Crystals—FT 241
- FT 243

**SEG ELECTRONICS CO. INC.**

1778 Flatbush Ave. Brooklyn 10, N. Y. CL 2-6333

Terms: Check with order. Well-rated firms net 10 days

**NEW MAHOGANY CABINETS**

Suitable for V.H.F. Converters do-it-yourself radio kits, etc. 9 1/2 x 39 1/4 x 6 1/4—samples sent on request—no reasonable offer refused.

**HASSETT STORAGE**

4906 Madison Street Chicago 44, Illinois

**WANTED**

(Continued from page 415)



**KOILED KORDS** 3 wires \$1.26  
22 inches long stretches to 9 ft.

Only a Few More Left  
**GONIOMETER**  
TYPE CFT-47372 — 250 to 1500 K.C.

**nightlighter** — Automatic lightswitch. Darkness throws the switch — turns lights on at dusk... off at dawn. Fools burglars who watch for signs of an empty house. Same as your city buys for \$45 on top of street lamp posts.

**\$15.95**

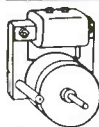

**TELECHRON Motors**

2 RPM	\$2.90	1 RPM	3.95
3 RPM	3.90	3 R.P. Hr.	2.85
4 RPM	3.90	1 R.P. 2Hr.	2.80
4 RPM	2.90	1 R.P. 12Hr.	3.25
3, 6 RPM	3.15	60 RPM	4.85
1 RPM	50 Cycles	51.85	

Laboratory Special 1 of Each Motor \$25

PLEASE INCLUDE POSTAGE

**BLAN** EST. 1922

64 R Dey St.  
New York 7.  
N. Y.

General Radio **VARIACS** in stock. Special Sale on a few 200-B (1 amp.) removed from equip't. \$8.95

**HAND WOUND 10 Sec. to 24 Min. TIMER SWITCH \$1.35**

6 Watt Most **POWERFUL TELECHRON MOTOR** 110v 60 Cy  
6 RPM reversible..... 10.00  
1 RPM .....\$6.50



**HAYDON TIMING MOTORS**

110v 60 cycle 30 RPM.	\$2.60
110v 60 cycle 1 RPM.	2.60
230v 52 RPM	\$1.00
60 cy/1 RPM	\$1.00
<b>HANSEN Synchron 4 rpm</b>	\$4.24
<b>CRAMER 4 rpm</b>	\$4.65

**DIEHL-DELCO**

P.M. motors. Made for 24 volts. Will work at lower speed at 12v. or 6v. Battery or Rectifier. Size 1"x1"x2" **\$3.75**



**APR-4 RECEIVERS**

Tuning units covering 38 to 4,000 MC.

**ALLTRONICS-HOWARD CO.**

Box 19, Boston 1, Mass. Richmond 2-0048

**BEARINGS —**

Miniatures; Precision; Stainless Steel; Special Sizes, Tolerance & Construction.

**RAWAY BEARING CO.**

4-8 Forsythe St. Walker 5-8150 N. Y. C. 2, N. Y.

**a TERRIFIC BARGAIN in a**

**SOLA CONSTANT-VOLTAGE TRANSFORMER**  
Ends fluctuating line voltage!

**Big Discount Off . . .**

the factory price at a 1. input 2,000 VA unit! And here's another bonus! This Air Forces 2,000 VA overstock, Sola Cat. No. 30768, has 4 inputs! 90-125 V., 190-250 V., 60 cy. or 50 cy. Isolated secondary is constant 115.0 V., -1% from no-load to full-load of 17.4 amp. So, if you choose, use it as a 220:115 V. step-down. And slash \$97.50 off the factory 1-innet price!



Brand new in original wood box. 4 cu. ft. Ship. wt. 254 lbs. F.O.B. Pasco, Wash. Only **\$147.50**

**THE M. R. COMPANY**  
P. O. Box 1220-B Beverly Hills, Calif.

**PREMIUM GRADE TUBULAR CAPACITORS**

- ★ leading make
- ★ Vitamin Q
- ★ 125 deg C
- ★ 5% tolerance
- ★ Glass-sealed, both ends insulated
- ★ Copies of certification supplied
- ★ Substantial quantities, stock delivery,

VERY LOW PRICES

write or phone **J. N. FINEBERG**  
1314 Market St. — RI-6-2130 — Phila. 3, Pa.

for the sweet taste of money

**TRY CANDEE!**  
We urgently need good gear!  
Since 1945, we've been buying:  
ARN-6                      ARN-7  
APN-9                      ART-13  
BC-224                     BC-348  
AS-313B Loops         Mil. & Comm.  
                                  Test Equip.  
"Selling to Candee is dandy!"  
WE PAY TOPS!  
**J. J. CANDEE CO.**  
4002 W. Burbank Blvd. Burbank, Calif.



## COMMUNICATIONS & TEST EQUIPMENT

Top quality communications and test equipment at low prices.

Here are a few leaders

- AN/TRC-1,2,3—Radio Telephone Repeater Sets
- ARC-1 & ARC-27—Transmitter Receivers
- ARN-6 & -14C—Radio Compass Receivers
- AS-313—Loop Antennas for ARN-6
- R-5/ARN-7—Compass Receivers
- ES-396—75 Meg. Marker Beacon Antenna
- R122A/ARN-12—Marker Beacon Receiver
- RCH—Navy Receiver
- RC-266—Antenna for SCR-717
- SCR-508—Mobile FM Radio Sets Complete
- TS-15A—Flux Meter 1200-9600 Gauss
- TS-125/AP—Power Output Meter
- TS-155A/UP—Signal Generators
- TS-323/UR—Frequency Meter Precision
- TS-452A/U Signal Generator
- RAL-8 Receives 1.5-30 MC (new W/Spares)
- Modulator Carrier Control System W.E.

Prices on request only  
Send us your requirements

We buy clean communications and test equipment unmodified. Top prices.

**MONTGOMERY EQUIPMENT CO.**  
14315 Bessemer St.  
Van Nuys, California  
Telephone: STate 6-4657  
Telegraph Station YHV  
Cable Address MONTEQUIP

### ENVIRONMENTAL

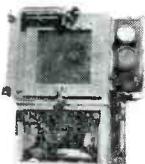

### TEST CHAMBER

Altitude: to 70,000 Ft  
Temperature: -70 to +200 F  
HUMIDITY

Good Used Condition

Priced far below original cost

For Details, Inspection:  
M. CONRAD 7208 Germantown Ave.  
CH 8-2700 Philadelphia 19, Pa.

# ELECTRON TUBES

CONSISTENTLY HIGH QUALITY — AT SENSIBLE PRICES!

SPECIALISTS IN JAN, W.E., SUBMINIATURE, 5000/6000 SERIES AND RECEIVING TYPES

GUARANTEED • UNUSED • BOXED • 1st QUALITY • WRITE FOR COMPLETE LIST

1AD4	\$.10	3B28	3.75	12AT7WA/	2.75	601A/5590	2.75	1626	1.15
1B24	5.00	3B29	4.75	6201	3.00	403A/6AK5	1.60	1635	1.60
1B24A	15.00	3C23	3.95	FG-27A	8.00	(WE)	.90	1654	2.00
1B32	.25	3C24/24G	1.70	FG-32	4.25	403B/5591	2.90	1850A	Write
1B35	3.35	3C45	6.75	35TG(surp)	2.00	404A/5847	12.50	5517	1.35
1B40	2.00	3E29	8.00	VC50/32 (cap)	8.00	408A	2.75	5528/C6L	5.00
1B63A	19.00	3J30	25.00	QK60	20.00	412A	3.50	5559/FG57	8.50
1N21	.10	3K20000LK	Write	QK61	21.50	416B	30.00	5638	2.75
1N23B	.65	4-65A(Surp)	15.00	RK65/5D23	7.50	417A/5842	12.00	5639	5.75
1N34	.45	4-125A	30.25	FG-81A	3.10	421A/5998	4.00	5642	1.00
1N65	.85	4-250A	35.00	100TH (surp)	6.25	GL434A	5.00	5721	125.00
1N70	1.50	4B24/EL3C	4.50	100TL (surp)	11.00	UE578	7.00	5725	1.50
1P23	1.75	4C35	15.00	FG-105	10.80	Z666/5J30	5.00	5726/6AL5W	.65
1P37	3.50	4J21	75.00	F-123A	6.75	GL-673	12.50	WL5736	110.00
1P41	2.50	4J36	70.00	F-128A	10.00	Z66A	5.00	5744	1.00
1Z2	1.25	4J37	70.00	VXR-130	1.00	Z66B	14.00	5787WA	5.00
CE2C	2.00	4PR60A	30.00	FG-166	12.00	Z66C	12.00	5802	4.50
CL-2	10.00	4X150A(surp)	19.00	FG-172	13.50	750TL (surp)	30.00	5812	1.00
23P1	3.95	4X500A(surp)	45.00	QK-181	12.50	805	4.00	5814	1.00
2C39A	10.00	4X500F	40.00	QK202/5721	125.00	807W/5933	1.50	5819	23.95
2C43	7.50	EL5B/4B22	5.50	249B	2.75	809	2.50	5829WA	3.00
2C51/396A	2.75	5BPA	3.00	HK253	5.00	814	2.50	5840CA	4.50
2C53	9.75	5C22	24.00	HK-257B/4E27	7.40	826	.50	5876	7.00
2D21W	.95	5CP1A	6.50	287A	2.20	829B	8.00	5879	1.20
2E24	2.25	5D21	5.50	304TL	12.50	832A	6.75	5998/421A	4.00
2E25	3.50	5D23/RK65	7.50	307A	.60	833A	36.00	6021	3.00
2E26	2.95	5J30/Z666	4.00	311A	5.50	837	1.25	6096	1.40
2E35	1.80	5JP2	3.50	313C	2.50	869B	Write	6100/6C4WA	2.00
2J21A	3.50	5JP5	5.50	313CD	2.50	872-A	.90	6130/3C45	4.75
2J22	3.50	5R4WG	3.00	QK319	100.00	872-A (GE)	2.75	6187	4.00
2J37	9.00	5Y3WGT	1.50	328A	3.50	902P1	2.00	6211	1.10
2J54	25.00	6AK5W	1.00	338A	3.75	918	1.10	6264	10.00
2K25	13.50	6BA6W/5749	1.25	350B	2.35	927	.95	6278/C5F14	20.00
2K30/410R	115.00	6BM6	30.00	354A	2.25	954	.10	6292	
2K45	35.00	6C4W	4.00	355A	10.00	958/958A	.35	(Dumont)	Write
2V3G	.65	C6L/5528	5.00	371B/VTT166	.75	CK1007	.45	6485	1.30
3824	1.50	6C21/450TL	13.50	375A	10.00	CK1026	2.35	8005	Write
3824WA	10.50	6SN7WGT	1.75	393A	4.50	R1130B	10.50	8008/872A	3.25
3825	5.00	8D21	Write	396A/2C51	3.00	HY-1269	3.35	8020	1.00
3826	3.95					1622	1.60	AX9903/5894	17.50

INDUSTRIAL XFMRS • VERY LARGE QUANTITY BRAND NEW, HIGH QUALITY COMM. TYPES • SPECIAL LOW PRICES • WRITE FOR LATEST LIST, FREE!

## TUBE CARTONS • STACKERS

Super gloss red & black, or plain glossy white. Both types with new safety partition that meets U. S. government specifications! Specify white or colored when ordering.

SIZE	FOR TUBE TYPE	PRICES		
		Quantity per case	Per case	Per 100
Miniature red & black 1" x 1" x 3"	6AU6, 6AL5, etc.	3000	\$27.00	\$1.00
Miniature glossy white		3000	27.00	1.00
GT red & black 1 1/4" x 1 1/2" x 3 1/2"	6SN7GT, 6W4GT, etc.	2000	22.50	1.25
GT glossy white		2000	22.50	1.25
Large GT red & black 1 1/2" x 1 1/2" x 4 1/2"	1B3, 6BQ6GT, etc.	1500	20.25	1.50
Large GT white		1500	20.25	1.50
G red & black 2" x 2" x 6"	5U4G, 6B6G, etc.	1000	18.00	2.00
G white		1000	18.00	2.00
Small Jumbo, white 3" x 3" x 7 1/2"	809, 866A, etc.	550	41.25	7.50
Large Jumbo, white 4" x 4" x 10"	813, 872A, etc.	300	27.00	10.00
Ministackers, white (holds 10 mintubes)		1000	13.50	1.50
GT stackers, white (holds 10 GT tubes)		1000	18.00	2.00
Lead sheaths for crystal diodes		Carton		
		Per Lot		
		Carton		
		Each		
		144	12.90	10



TERMS: 25% Deposit with Order. Balance C.O.D.—or Send Full Remittance with Order. Well Rated (D&B) Firms, Net 10. All Items Subject to Stock Depletion and Price Variation Without Prior Notice. All Merchandise Fully Guaranteed for Cost of Merchandise Only. Minimum Order \$10.00.

Walker 5-7000 - 24 Hour Phone Service

Cable: Barrylect, NY  
Teleg: am: Barry, Fax, NYC  
Tw: NY 1-3731-U

# BARRY ELECTRONICS CORP.

512 BROADWAY N.Y. 12, N.Y.

# AN CONNECTORS

**FAST DELIVERY**

**FROM STOCK**

**LOW PRICES**

Let us quote on your requirements.

All comply with government specifications

*Wilgreen Industries*  
99 MURRAY ST., NEW YORK 7, N. Y.  
Worth 4-2490-1-2

Cadmium or olive drab finish.



PRECISION POTENTIOMETERS
HELIPOT, G.R. MULTIPOT, MICROPOT
FAIRCHILD, BOURNS, DEJUR.

SINCE 1945
CERTIFIED
TUBE TESTING
AGEING &
RETEST FACILITIES
WRITE!

TUBES
INSPECTED
"TAB" TESTED
GUARANTEED!!!
WRITE FOR COMPLETE TUBE LIST

"TAB" THAT'S A BUY

450 MA CHOKE S3 @ Qlys. 10
W.E. Mfg. for U.S.N. Rated 4-Hy
450ma/3K/27 ohms Hermetic
Sealed & Cased 4 1/2 x 3 1/4 x 1 1/4
Lbs. #CHI001 SPECIAL \$4.00

Table of tube types and prices: 6AG5, 6AR5, 6BE6, 6BE7, 6BE8, 6BE9, 6BE9A, 6BE9B, 6BE9C, 6BE9D, 6BE9E, 6BE9F, 6BE9G, 6BE9H, 6BE9I, 6BE9J, 6BE9K, 6BE9L, 6BE9M, 6BE9N, 6BE9O, 6BE9P, 6BE9Q, 6BE9R, 6BE9S, 6BE9T, 6BE9U, 6BE9V, 6BE9W, 6BE9X, 6BE9Y, 6BE9Z, 6BE9AA, 6BE9AB, 6BE9AC, 6BE9AD, 6BE9AE, 6BE9AF, 6BE9AG, 6BE9AH, 6BE9AI, 6BE9AJ, 6BE9AK, 6BE9AL, 6BE9AM, 6BE9AN, 6BE9AO, 6BE9AP, 6BE9AQ, 6BE9AR, 6BE9AS, 6BE9AT, 6BE9AU, 6BE9AV, 6BE9AW, 6BE9AX, 6BE9AY, 6BE9AZ, 6BE9BA, 6BE9BB, 6BE9BC, 6BE9BD, 6BE9BE, 6BE9BF, 6BE9BG, 6BE9BH, 6BE9BI, 6BE9BJ, 6BE9BK, 6BE9BL, 6BE9BM, 6BE9BN, 6BE9BO, 6BE9BP, 6BE9BQ, 6BE9BR, 6BE9BS, 6BE9BT, 6BE9BU, 6BE9BV, 6BE9BW, 6BE9BX, 6BE9BY, 6BE9BZ, 6BE9CA, 6BE9CB, 6BE9CC, 6BE9CD, 6BE9CE, 6BE9CF, 6BE9CG, 6BE9CH, 6BE9CI, 6BE9CJ, 6BE9CK, 6BE9CL, 6BE9CM, 6BE9CN, 6BE9CO, 6BE9CP, 6BE9CQ, 6BE9CR, 6BE9CS, 6BE9CT, 6BE9CU, 6BE9CV, 6BE9CW, 6BE9CX, 6BE9CY, 6BE9CZ, 6BE9DA, 6BE9DB, 6BE9DC, 6BE9DD, 6BE9DE, 6BE9DF, 6BE9DG, 6BE9DH, 6BE9DI, 6BE9DJ, 6BE9DK, 6BE9DL, 6BE9DM, 6BE9DN, 6BE9DO, 6BE9DP, 6BE9DQ, 6BE9DR, 6BE9DS, 6BE9DT, 6BE9DU, 6BE9DV, 6BE9DW, 6BE9DX, 6BE9DY, 6BE9DZ, 6BE9EA, 6BE9EB, 6BE9EC, 6BE9ED, 6BE9EE, 6BE9EF, 6BE9EG, 6BE9EH, 6BE9EI, 6BE9EJ, 6BE9EK, 6BE9EL, 6BE9EM, 6BE9EN, 6BE9EO, 6BE9EP, 6BE9EQ, 6BE9ER, 6BE9ES, 6BE9ET, 6BE9EU, 6BE9EV, 6BE9EW, 6BE9EX, 6BE9EY, 6BE9EZ, 6BE9FA, 6BE9FB, 6BE9FC, 6BE9FD, 6BE9FE, 6BE9FF, 6BE9FG, 6BE9FH, 6BE9FI, 6BE9FJ, 6BE9FK, 6BE9FL, 6BE9FM, 6BE9FN, 6BE9FO, 6BE9FP, 6BE9FQ, 6BE9FR, 6BE9FS, 6BE9FT, 6BE9FU, 6BE9FV, 6BE9FW, 6BE9FX, 6BE9FY, 6BE9FZ, 6BE9GA, 6BE9GB, 6BE9GC, 6BE9GD, 6BE9GE, 6BE9GF, 6BE9GG, 6BE9GH, 6BE9GI, 6BE9GJ, 6BE9GK, 6BE9GL, 6BE9GM, 6BE9GN, 6BE9GO, 6BE9GP, 6BE9GQ, 6BE9GR, 6BE9GS, 6BE9GT, 6BE9GU, 6BE9GV, 6BE9GW, 6BE9GX, 6BE9GY, 6BE9GZ, 6BE9HA, 6BE9HB, 6BE9HC, 6BE9HD, 6BE9HE, 6BE9HF, 6BE9HG, 6BE9HH, 6BE9HI, 6BE9HJ, 6BE9HK, 6BE9HL, 6BE9HM, 6BE9HN, 6BE9HO, 6BE9HP, 6BE9HQ, 6BE9HR, 6BE9HS, 6BE9HT, 6BE9HU, 6BE9HV, 6BE9HW, 6BE9HX, 6BE9HY, 6BE9HZ, 6BE9IA, 6BE9IB, 6BE9IC, 6BE9ID, 6BE9IE, 6BE9IF, 6BE9IG, 6BE9IH, 6BE9II, 6BE9IJ, 6BE9IK, 6BE9IL, 6BE9IM, 6BE9IN, 6BE9IO, 6BE9IP, 6BE9IQ, 6BE9IR, 6BE9IS, 6BE9IT, 6BE9IU, 6BE9IV, 6BE9IW, 6BE9IX, 6BE9IY, 6BE9IZ, 6BE9JA, 6BE9JB, 6BE9JC, 6BE9JD, 6BE9JE, 6BE9JF, 6BE9JG, 6BE9JH, 6BE9JI, 6BE9JJ, 6BE9JK, 6BE9JL, 6BE9JM, 6BE9JN, 6BE9JO, 6BE9JP, 6BE9JQ, 6BE9JR, 6BE9JS, 6BE9JT, 6BE9JU, 6BE9JV, 6BE9JW, 6BE9JX, 6BE9JY, 6BE9JZ, 6BE9KA, 6BE9KB, 6BE9KC, 6BE9KD, 6BE9KE, 6BE9KF, 6BE9KG, 6BE9KH, 6BE9KI, 6BE9KJ, 6BE9KL, 6BE9KM, 6BE9KN, 6BE9KO, 6BE9KP, 6BE9KQ, 6BE9KR, 6BE9KS, 6BE9KT, 6BE9KU, 6BE9KV, 6BE9KW, 6BE9KX, 6BE9KY, 6BE9KZ, 6BE9LA, 6BE9LB, 6BE9LC, 6BE9LD, 6BE9LE, 6BE9LF, 6BE9LG, 6BE9LH, 6BE9LI, 6BE9LJ, 6BE9LK, 6BE9LL, 6BE9LM, 6BE9LN, 6BE9LO, 6BE9LP, 6BE9LQ, 6BE9LR, 6BE9LS, 6BE9LT, 6BE9LU, 6BE9LV, 6BE9LW, 6BE9LX, 6BE9LY, 6BE9LZ, 6BE9MA, 6BE9MB, 6BE9MC, 6BE9MD, 6BE9ME, 6BE9MF, 6BE9MG, 6BE9MH, 6BE9MI, 6BE9MJ, 6BE9MK, 6BE9ML, 6BE9MM, 6BE9MN, 6BE9MO, 6BE9MP, 6BE9MQ, 6BE9MR, 6BE9MS, 6BE9MT, 6BE9MU, 6BE9MV, 6BE9MW, 6BE9MX, 6BE9MY, 6BE9MZ, 6BE9NA, 6BE9NB, 6BE9NC, 6BE9ND, 6BE9NE, 6BE9NF, 6BE9NG, 6BE9NH, 6BE9NI, 6BE9NJ, 6BE9NK, 6BE9NL, 6BE9NM, 6BE9NN, 6BE9NO, 6BE9NP, 6BE9NQ, 6BE9NR, 6BE9NS, 6BE9NT, 6BE9NU, 6BE9NV, 6BE9NW, 6BE9NX, 6BE9NY, 6BE9NZ, 6BE9OA, 6BE9OB, 6BE9OC, 6BE9OD, 6BE9OE, 6BE9OF, 6BE9OG, 6BE9OH, 6BE9OI, 6BE9OJ, 6BE9OK, 6BE9OL, 6BE9OM, 6BE9ON, 6BE9OO, 6BE9OP, 6BE9OQ, 6BE9OR, 6BE9OS, 6BE9OT, 6BE9OU, 6BE9OV, 6BE9OW, 6BE9OX, 6BE9OY, 6BE9OZ, 6BE9PA, 6BE9PB, 6BE9PC, 6BE9PD, 6BE9PE, 6BE9PF, 6BE9PG, 6BE9PH, 6BE9PI, 6BE9PJ, 6BE9PK, 6BE9PL, 6BE9PM, 6BE9PN, 6BE9PO, 6BE9PP, 6BE9PQ, 6BE9PR, 6BE9PS, 6BE9PT, 6BE9PU, 6BE9PV, 6BE9PW, 6BE9PX, 6BE9PY, 6BE9PZ, 6BE9QA, 6BE9QB, 6BE9QC, 6BE9QD, 6BE9QE, 6BE9QF, 6BE9QG, 6BE9QH, 6BE9QI, 6BE9QJ, 6BE9QK, 6BE9QL, 6BE9QM, 6BE9QN, 6BE9QO, 6BE9QP, 6BE9QQ, 6BE9QR, 6BE9QS, 6BE9QT, 6BE9QU, 6BE9QV, 6BE9QW, 6BE9QX, 6BE9QY, 6BE9QZ, 6BE9RA, 6BE9RB, 6BE9RC, 6BE9RD, 6BE9RE, 6BE9RF, 6BE9RG, 6BE9RH, 6BE9RI, 6BE9RJ, 6BE9RK, 6BE9RL, 6BE9RM, 6BE9RN, 6BE9RO, 6BE9RP, 6BE9RQ, 6BE9RR, 6BE9RS, 6BE9RT, 6BE9RU, 6BE9RV, 6BE9RW, 6BE9RX, 6BE9RY, 6BE9RZ, 6BE9SA, 6BE9SB, 6BE9SC, 6BE9SD, 6BE9SE, 6BE9SF, 6BE9SG, 6BE9SH, 6BE9SI, 6BE9SJ, 6BE9SK, 6BE9SL, 6BE9SM, 6BE9SN, 6BE9SO, 6BE9SP, 6BE9SQ, 6BE9SR, 6BE9SS, 6BE9ST, 6BE9SU, 6BE9SV, 6BE9SW, 6BE9SX, 6BE9SY, 6BE9SZ, 6BE9TA, 6BE9TB, 6BE9TC, 6BE9TD, 6BE9TE, 6BE9TF, 6BE9TG, 6BE9TH, 6BE9TI, 6BE9TJ, 6BE9TK, 6BE9TL, 6BE9TM, 6BE9TN, 6BE9TO, 6BE9TP, 6BE9TQ, 6BE9TR, 6BE9TS, 6BE9TT, 6BE9TU, 6BE9TV, 6BE9TW, 6BE9TX, 6BE9TY, 6BE9TZ, 6BE9UA, 6BE9UB, 6BE9UC, 6BE9UD, 6BE9UE, 6BE9UF, 6BE9UG, 6BE9UH, 6BE9UI, 6BE9UJ, 6BE9UK, 6BE9UL, 6BE9UM, 6BE9UN, 6BE9UO, 6BE9UP, 6BE9UQ, 6BE9UR, 6BE9US, 6BE9UT, 6BE9UU, 6BE9UV, 6BE9UW, 6BE9UX, 6BE9UY, 6BE9UZ, 6BE9VA, 6BE9VB, 6BE9VC, 6BE9VD, 6BE9VE, 6BE9VF, 6BE9VG, 6BE9VH, 6BE9VI, 6BE9VJ, 6BE9VK, 6BE9VL, 6BE9VM, 6BE9VN, 6BE9VO, 6BE9VP, 6BE9VQ, 6BE9VR, 6BE9VS, 6BE9VT, 6BE9VU, 6BE9VV, 6BE9VW, 6BE9VX, 6BE9VY, 6BE9VZ, 6BE9WA, 6BE9WB, 6BE9WC, 6BE9WD, 6BE9WE, 6BE9WF, 6BE9WG, 6BE9WH, 6BE9WI, 6BE9WJ, 6BE9WK, 6BE9WL, 6BE9WM, 6BE9WN, 6BE9WO, 6BE9WP, 6BE9WQ, 6BE9WR, 6BE9WS, 6BE9WT, 6BE9WU, 6BE9WV, 6BE9WW, 6BE9WX, 6BE9WY, 6BE9WZ, 6BE9XA, 6BE9XB, 6BE9XC, 6BE9XD, 6BE9XE, 6BE9XF, 6BE9XG, 6BE9XH, 6BE9XI, 6BE9XJ, 6BE9XK, 6BE9XL, 6BE9XM, 6BE9XN, 6BE9XO, 6BE9XP, 6BE9XQ, 6BE9XR, 6BE9XS, 6BE9XT, 6BE9XU, 6BE9XV, 6BE9XW, 6BE9XX, 6BE9XY, 6BE9XZ, 6BE9YA, 6BE9YB, 6BE9YC, 6BE9YD, 6BE9YE, 6BE9YF, 6BE9YG, 6BE9YH, 6BE9YI, 6BE9YJ, 6BE9YK, 6BE9YL, 6BE9YM, 6BE9YN, 6BE9YO, 6BE9YP, 6BE9YQ, 6BE9YR, 6BE9YS, 6BE9YT, 6BE9YU, 6BE9YV, 6BE9YW, 6BE9YX, 6BE9YY, 6BE9YZ, 6BE9ZA, 6BE9ZB, 6BE9ZC, 6BE9ZD, 6BE9ZE, 6BE9ZF, 6BE9ZG, 6BE9ZH, 6BE9ZI, 6BE9ZJ, 6BE9ZK, 6BE9ZL, 6BE9ZM, 6BE9ZN, 6BE9ZO, 6BE9ZP, 6BE9ZQ, 6BE9ZR, 6BE9ZS, 6BE9ZT, 6BE9ZU, 6BE9ZV, 6BE9ZW, 6BE9ZX, 6BE9ZY, 6BE9ZZ

"TABTRAN" Rectifier Xfms
Sec'd Volts (DUAL) 0-9-15-28-28-0-9-15-18
Series Sec'ds 0-3-6-9-12-15-18-21-24-27-30-33-36 Volts

STEVENS ARNOLD PRECISION
DC-AC CHOPPER TYPE CH365
SPDT/COIL 26VDC/800 Ohm IMP
60Cys/830 Ohm 400Cys/1100 Ohm Use as Chopper
Rectifier, DEMODULATOR, Sq. Wave Generator
Reg. \$20.00 SPECIAL \$4.00, 3for \$11, 20for \$55

New "TEKSEL" SELENIUM RECTIFIERS\* Engineered for Automation & Industry "TAB" Distributors for "Technical Apparatus Builders" Mfgs. Industrial Power Rectifiers with "KOOLTAB" Current Collectors & Brackets. Also to Your Specs Any Current. Quick Deliveries! Replaces Our Specialty. Write for Quantity Prices.

Table of tube types and prices: 6AG5, 6AR5, 6BE6, 6BE7, 6BE8, 6BE9, 6BE9A, 6BE9B, 6BE9C, 6BE9D, 6BE9E, 6BE9F, 6BE9G, 6BE9H, 6BE9I, 6BE9J, 6BE9K, 6BE9L, 6BE9M, 6BE9N, 6BE9O, 6BE9P, 6BE9Q, 6BE9R, 6BE9S, 6BE9T, 6BE9U, 6BE9V, 6BE9W, 6BE9X, 6BE9Y, 6BE9Z, 6BE9AA, 6BE9AB, 6BE9AC, 6BE9AD, 6BE9AE, 6BE9AF, 6BE9AG, 6BE9AH, 6BE9AI, 6BE9AJ, 6BE9AK, 6BE9AL, 6BE9AM, 6BE9AN, 6BE9AO, 6BE9AP, 6BE9AQ, 6BE9AR, 6BE9AS, 6BE9AT, 6BE9AU, 6BE9AV, 6BE9AW, 6BE9AX, 6BE9AY, 6BE9AZ, 6BE9BA, 6BE9BB, 6BE9BC, 6BE9BD, 6BE9BE, 6BE9BF, 6BE9BG, 6BE9BH, 6BE9BI, 6BE9BJ, 6BE9BK, 6BE9BL, 6BE9BM, 6BE9BN, 6BE9BO, 6BE9BP, 6BE9BQ, 6BE9BR, 6BE9BS, 6BE9BT, 6BE9BU, 6BE9BV, 6BE9BW, 6BE9BX, 6BE9BY, 6BE9BZ, 6BE9CA, 6BE9CB, 6BE9CC, 6BE9CD, 6BE9CE, 6BE9CF, 6BE9CG, 6BE9CH, 6BE9CI, 6BE9CJ, 6BE9CK, 6BE9CL, 6BE9CM, 6BE9CN, 6BE9CO, 6BE9CP, 6BE9CQ, 6BE9CR, 6BE9CS, 6BE9CT, 6BE9CU, 6BE9CV, 6BE9CW, 6BE9CX, 6BE9CY, 6BE9CZ, 6BE9DA, 6BE9DB, 6BE9DC, 6BE9DD, 6BE9DE, 6BE9DF, 6BE9DG, 6BE9DH, 6BE9DI, 6BE9DJ, 6BE9DK, 6BE9DL, 6BE9DM, 6BE9DN, 6BE9DO, 6BE9DP, 6BE9DQ, 6BE9DR, 6BE9DS, 6BE9DT, 6BE9DU, 6BE9DV, 6BE9DW, 6BE9DX, 6BE9DY, 6BE9DZ, 6BE9EA, 6BE9EB, 6BE9EC, 6BE9ED, 6BE9EE, 6BE9EF, 6BE9EG, 6BE9EH, 6BE9EI, 6BE9EJ, 6BE9EK, 6BE9EL, 6BE9EM, 6BE9EN, 6BE9EO, 6BE9EP, 6BE9EQ, 6BE9ER, 6BE9ES, 6BE9ET, 6BE9EU, 6BE9EV, 6BE9EW, 6BE9EX, 6BE9EY, 6BE9EZ, 6BE9FA, 6BE9FB, 6BE9FC, 6BE9FD, 6BE9FE, 6BE9FF, 6BE9FG, 6BE9FH, 6BE9FI, 6BE9FJ, 6BE9FK, 6BE9FL, 6BE9FM, 6BE9FN, 6BE9FO, 6BE9FP, 6BE9FQ, 6BE9FR, 6BE9FS, 6BE9FT, 6BE9FU, 6BE9FV, 6BE9FW, 6BE9FX, 6BE9FY, 6BE9FZ, 6BE9GA, 6BE9GB, 6BE9GC, 6BE9GD, 6BE9GE, 6BE9GF, 6BE9GG, 6BE9GH, 6BE9GI, 6BE9GJ, 6BE9GK, 6BE9GL, 6BE9GM, 6BE9GN, 6BE9GO, 6BE9GP, 6BE9GQ, 6BE9GR, 6BE9GS, 6BE9GT, 6BE9GU, 6BE9GV, 6BE9GW, 6BE9GX, 6BE9GY, 6BE9GZ, 6BE9HA, 6BE9HB, 6BE9HC, 6BE9HD, 6BE9HE, 6BE9HF, 6BE9HG, 6BE9HH, 6BE9HI, 6BE9HJ, 6BE9HK, 6BE9HL, 6BE9HM, 6BE9HN, 6BE9HO, 6BE9HP, 6BE9HQ, 6BE9HR, 6BE9HS, 6BE9HT, 6BE9HU, 6BE9HV, 6BE9HW, 6BE9HX, 6BE9HY, 6BE9HZ, 6BE9IA, 6BE9IB, 6BE9IC, 6BE9ID, 6BE9IE, 6BE9IF, 6BE9IG, 6BE9IH, 6BE9II, 6BE9IJ, 6BE9IK, 6BE9IL, 6BE9IM, 6BE9IN, 6BE9IO, 6BE9IP, 6BE9IQ, 6BE9IR, 6BE9IS, 6BE9IT, 6BE9IU, 6BE9IV, 6BE9IW, 6BE9IX, 6BE9IY, 6BE9IZ, 6BE9JA, 6BE9JB, 6BE9JC, 6BE9JD, 6BE9JE, 6BE9JF, 6BE9JG, 6BE9JH, 6BE9JI, 6BE9JJ, 6BE9JK, 6BE9JL, 6BE9JM, 6BE9JN, 6BE9JO, 6BE9JP, 6BE9JQ, 6BE9JR, 6BE9JS, 6BE9JT, 6BE9JU, 6BE9JV, 6BE9JW, 6BE9JX, 6BE9JY, 6BE9JZ, 6BE9KA, 6BE9KB, 6BE9KC, 6BE9KD, 6BE9KE, 6BE9KF, 6BE9KG, 6BE9KH, 6BE9KI, 6BE9KJ, 6BE9KL, 6BE9KM, 6BE9KN, 6BE9KO, 6BE9KP, 6BE9KQ, 6BE9KR, 6BE9KS, 6BE9KT, 6BE9KU, 6BE9KV, 6BE9KW, 6BE9KX, 6BE9KY, 6BE9KZ, 6BE9LA, 6BE9LB, 6BE9LC, 6BE9LD, 6BE9LE, 6BE9LF, 6BE9LG, 6BE9LH, 6BE9LI, 6BE9LJ, 6BE9LK, 6BE9LL, 6BE9LM, 6BE9LN, 6BE9LO, 6BE9LP, 6BE9LQ, 6BE9LR, 6BE9LS, 6BE9LT, 6BE9LU, 6BE9LV, 6BE9LW, 6BE9LX, 6BE9LY, 6BE9LZ, 6BE9MA, 6BE9MB, 6BE9MC, 6BE9MD, 6BE9ME, 6BE9MF, 6BE9MG, 6BE9MH, 6BE9MI, 6BE9MJ, 6BE9MK, 6BE9ML, 6BE9MM, 6BE9MN, 6BE9MO, 6BE9MP, 6BE9MQ, 6BE9MR, 6BE9MS, 6BE9MT, 6BE9MU, 6BE9MV, 6BE9MW, 6BE9MX, 6BE9MY, 6BE9MZ, 6BE9NA, 6BE9NB, 6BE9NC, 6BE9ND, 6BE9NE, 6BE9NF, 6BE9NG, 6BE9NH, 6BE9NI, 6BE9NJ, 6BE9NK, 6BE9NL, 6BE9NM, 6BE9NN, 6BE9NO, 6BE9NP, 6BE9NQ, 6BE9NR, 6BE9NS, 6BE9NT, 6BE9NU, 6BE9NV, 6BE9NW, 6BE9NX, 6BE9NY, 6BE9NZ, 6BE9OA, 6BE9OB, 6BE9OC, 6BE9OD, 6BE9OE, 6BE9OF, 6BE9OG, 6BE9OH, 6BE9OI, 6BE9OJ, 6BE9OK, 6BE9OL, 6BE9OM, 6BE9ON, 6BE9OO, 6BE9OP, 6BE9OQ, 6BE9OR, 6BE9OS, 6BE9OT, 6BE9OU, 6BE9OV, 6BE9OW, 6BE9OX, 6BE9OY, 6BE9OZ, 6BE9PA, 6BE9PB, 6BE9PC, 6BE9PD, 6BE9PE, 6BE9PF, 6BE9PG, 6BE9PH, 6BE9PI, 6BE9PJ, 6BE9PK, 6BE9PL, 6BE9PM, 6BE9PN, 6BE9PO, 6BE9PP, 6BE9PQ, 6BE9PR, 6BE9PS, 6BE9PT, 6BE9PU, 6BE9PV, 6BE9PW, 6BE9PX, 6BE9PY, 6BE9PZ, 6BE9QA, 6BE9QB, 6BE9QC, 6BE9QD, 6BE9QE, 6BE9QF, 6BE9QG, 6BE9QH, 6BE9QI, 6BE9QJ, 6BE9QK, 6BE9QL, 6BE9QM, 6BE9QN, 6BE9QO, 6BE9QP, 6BE9QQ, 6BE9QR, 6BE9QS, 6BE9QT, 6BE9QU, 6BE9QV, 6BE9QW, 6BE9QX, 6BE9QY, 6BE9QZ, 6BE9RA, 6BE9RB, 6BE9RC, 6BE9RD, 6BE9RE, 6BE9RF, 6BE9RG, 6BE9RH, 6BE9RI, 6BE9RJ, 6BE9RK, 6BE9RL, 6BE9RM, 6BE9RN, 6BE9RO, 6BE9RP, 6BE9RQ, 6BE9RR, 6BE9RS, 6BE9RT, 6BE9RU, 6BE9RV, 6BE9RW, 6BE9RX, 6BE9RY, 6BE9RZ, 6BE9SA, 6BE9SB, 6BE9SC, 6BE9SD, 6BE9SE, 6BE9SF, 6BE9SG, 6BE9SH, 6BE9SI, 6BE9SJ, 6BE9SK, 6BE9SL, 6BE9SM, 6BE9SN, 6BE9SO, 6BE9SP, 6BE9SQ, 6BE9SR, 6BE9SS, 6BE9ST, 6BE9SU, 6BE9SV, 6BE9SW, 6BE9SX, 6BE9SY, 6BE9SZ, 6BE9TA, 6BE9TB, 6BE9TC, 6BE9TD, 6BE9TE, 6BE9TF, 6BE9TG, 6BE9TH, 6BE9TI, 6BE9TJ, 6BE9TK, 6BE9TL, 6BE9TM, 6BE9TN, 6BE9TO, 6BE9TP, 6BE9TQ, 6BE9TR, 6BE9TS, 6BE9TT, 6BE9TU, 6BE9TV, 6BE9TW, 6BE9TX, 6BE9TY, 6BE9TZ, 6BE9UA, 6BE9UB, 6BE9UC, 6BE9UD, 6BE9UE, 6BE9UF, 6BE9UG, 6BE9UH, 6BE9UI, 6BE9UJ, 6BE9UK, 6BE9UL, 6BE9UM, 6BE9UN, 6BE9UO, 6BE9UP, 6BE9UQ, 6BE9UR, 6BE9US, 6BE9UT, 6BE9UU, 6BE9UV, 6BE9UW, 6BE9UX, 6BE9UY, 6BE9UZ, 6BE9VA, 6BE9VB, 6BE9VC, 6BE9VD, 6BE9VE, 6BE9VF, 6BE9VG, 6BE9VH, 6BE9VI, 6BE9VJ, 6BE9VK, 6BE9VL, 6BE9VM, 6BE9VN, 6BE9VO, 6BE9VP, 6BE9VQ, 6BE9VR, 6BE9VS, 6BE9VT, 6BE9VU, 6BE9VV, 6BE9VW, 6BE9VX, 6BE9VY, 6BE9VZ, 6BE9WA, 6BE9WB, 6BE9WC, 6BE9WD, 6BE9WE, 6BE9WF, 6BE9WG, 6BE9WH, 6BE9WI, 6BE9WJ, 6BE9WK, 6BE9WL, 6BE9WM, 6BE9WN, 6BE9WO, 6BE9WP, 6BE9WQ, 6BE9WR, 6BE9WS, 6BE9WT, 6BE9WU, 6BE9WV, 6BE9WW, 6BE9WX, 6BE9WY, 6BE9WZ, 6BE9XA, 6BE9XB, 6BE9XC, 6BE9XD, 6BE9XE, 6BE9XF, 6BE9XG, 6BE9XH, 6BE9XI, 6BE9XJ, 6BE9XK, 6BE9XL, 6BE9XM, 6BE9XN, 6BE9XO, 6BE9XP, 6BE9XQ, 6BE9XR, 6BE9XS, 6BE9XT, 6BE9XU, 6BE9XV, 6BE9XW, 6BE9XX, 6BE9XY, 6BE9XZ, 6BE9YA, 6BE9YB, 6BE9YC, 6BE9YD, 6BE9YE, 6BE9YF, 6BE9YG, 6BE9YH, 6BE9YI, 6BE9YJ, 6BE9YK, 6BE9YL, 6BE9YM, 6BE9YN, 6BE9YO, 6BE9YP, 6BE9YQ, 6BE9YR, 6BE9YS, 6BE9YT, 6BE9YU, 6BE9YV, 6BE9YW, 6BE9YX, 6BE9YY, 6BE9YZ, 6BE9ZA, 6BE9ZB, 6BE9ZC, 6BE9ZD, 6BE9ZE, 6BE9ZF, 6BE9ZG, 6BE9ZH, 6BE9ZI, 6BE9ZJ, 6BE9ZK, 6BE9ZL, 6BE9ZM, 6BE9ZN, 6BE9ZO, 6BE9ZP, 6BE9ZQ, 6BE9ZR, 6BE9ZS, 6BE9ZT, 6BE9ZU, 6BE9ZV, 6BE9ZW, 6BE9ZX, 6BE9ZY, 6BE9ZZ

120 or 230 VDC AC/Transformer
For Selenium F.W.B. Rectifier
All Primaries 115 & 230V AC/Sec/10 Input
Secondary 0-125, 150, 160, 165, Nema Specs
TR4009\* @ 5 Amp Continuous Duty \$3.50
TR4010\* @ 10 Amp Continuous Duty \$7.25
TR4011\* @ 5 Amp Continuous Duty \$3.50
TR4012\* @ 10 Amp Continuous Duty \$7.25
\*Dual Pri 115 & 230VAC/60cys INPUT

"DUMONT" TV-Hi-Fi-LAB
Hi-Fi-Lab. Power Supply can
be used for Radio, Color and
Projection TV, Snooposcopes,
Hi-Fi Testing. Delivers 20 to
200 KV fully regulated & ultra
stable\* contains 3 tube voltage regulator, 3 sense
diodes & sense protection etc. 500mA 30V Regulated
Constant Voltage Hi Current Power Supply
Delivers 420VDC @ 350ma pure DC & 6.3V/0A
 filament. Includes 50 tubes: 6X4, 6X5, 6X6, 6X7, 6X8, 6X9,
2/6AL5, 2/6BD6G, 3/1B3, 4S, 6V6, 6BJ7, 6BE6, 6BE7,
17VAC/600y/10. DUMONT RA119 for 30" TV
& Diagram. \$200 value. \$25.00, 2/\$45, 5/\$100

Table of tube types and prices: 6AG5, 6AR5, 6BE6, 6BE7, 6BE8, 6BE9, 6BE9A, 6BE9B, 6BE9C, 6BE9D, 6BE9E, 6BE9F, 6BE9G, 6BE9H, 6BE9I, 6BE9J, 6BE9K, 6BE9L, 6BE9M, 6BE9N, 6BE9O, 6BE9P, 6BE9Q, 6BE9R, 6BE9S, 6BE9T, 6BE9U, 6BE9V, 6BE9W, 6BE9X, 6BE9Y, 6BE9Z, 6BE9AA, 6BE9AB, 6BE9AC, 6BE9AD, 6BE9AE, 6BE9AF, 6BE9AG, 6BE9AH, 6BE9AI, 6BE9AJ, 6BE9AK, 6BE9AL, 6BE9AM, 6BE9AN, 6BE9AO, 6BE9AP, 6BE9AQ, 6BE9AR, 6BE9AS, 6BE9AT, 6BE9AU, 6BE9AV, 6BE9AW, 6BE9AX, 6BE9AY, 6BE9AZ, 6BE9BA, 6BE9BB, 6BE9BC, 6BE9BD, 6BE9BE, 6BE9BF, 6BE9BG, 6BE9BH, 6BE9BI, 6BE9BJ, 6BE9BK, 6BE9BL, 6BE9BM, 6BE9BN, 6BE9BO, 6BE9BP, 6BE9BQ, 6BE9BR, 6BE9BS, 6BE9BT, 6BE9BU, 6BE9BV, 6BE9BW, 6BE9BX, 6BE9BY, 6BE9BZ, 6BE9CA, 6BE9CB, 6BE9CC, 6BE9CD, 6BE9CE, 6BE9CF, 6BE9CG, 6BE9CH, 6BE9CI, 6BE9CJ, 6BE9CK, 6BE9CL, 6BE9CM, 6BE9CN, 6BE9CO, 6BE9CP, 6BE9CQ, 6BE9CR, 6BE9CS, 6BE9CT, 6BE9CU, 6BE9CV, 6BE9CW, 6BE9CX, 6BE9CY, 6BE9CZ, 6BE9DA, 6BE9DB, 6BE9DC, 6BE9DD, 6BE9DE, 6BE9DF, 6BE9DG, 6BE9DH, 6BE9DI, 6BE9DJ, 6BE9DK, 6BE9DL, 6BE9DM, 6BE9DN, 6BE9DO, 6BE9DP, 6BE9DQ, 6BE9DR, 6BE9DS, 6BE9DT, 6BE9DU, 6BE9DV, 6BE9DW, 6BE9DX, 6BE9DY, 6BE9DZ, 6BE9EA, 6BE9EB, 6BE9EC, 6BE9ED, 6BE9EE, 6BE9EF, 6BE9EG, 6BE9EH, 6BE9EI, 6BE9EJ, 6BE9EK, 6BE9EL, 6BE9EM, 6BE9EN, 6BE9EO, 6BE9EP, 6BE9EQ, 6BE9ER, 6BE9ES, 6BE9ET, 6BE9EU, 6BE9EV, 6BE9EW, 6BE9EX, 6BE9EY, 6BE9EZ, 6BE9FA, 6BE9FB, 6BE9FC, 6BE9FD, 6BE9FE, 6BE9FF, 6BE9FG, 6BE9FH, 6BE9FI, 6BE9FJ, 6BE9FK, 6BE9FL, 6BE9FM, 6BE9FN, 6BE9FO, 6BE9FP, 6BE9FQ, 6BE9FR, 6BE9FS, 6BE9FT, 6BE9FU, 6BE9FV, 6BE9FW, 6BE9FX, 6BE9FY, 6BE9FZ, 6BE9GA, 6BE9GB, 6BE9GC, 6BE9GD, 6BE9GE, 6BE9GF, 6BE9GG, 6BE9GH, 6BE9GI, 6BE9GJ, 6BE9GK, 6BE9GL, 6BE9GM, 6BE9GN, 6BE9GO, 6BE9GP, 6BE9GQ, 6BE9GR, 6BE9GS, 6BE9GT, 6BE9GU, 6BE9GV, 6BE9GW, 6BE9GX, 6BE9GY, 6BE9GZ, 6BE9HA, 6BE9HB, 6BE9HC, 6BE9HD, 6BE9HE, 6BE9HF, 6BE9HG, 6BE9HH, 6BE9HI, 6BE9HJ, 6BE9HK, 6BE9HL, 6BE9HM, 6BE9HN, 6BE9HO, 6BE9HP, 6BE9HQ, 6BE9HR, 6BE9HS, 6BE9HT, 6BE9HU, 6BE9HV, 6BE9HW, 6BE9HX, 6BE9HY, 6BE9HZ, 6BE9IA, 6BE9IB, 6BE9IC, 6BE9ID, 6BE9IE, 6BE9IF, 6BE9IG, 6BE9IH, 6BE9II, 6BE9IJ, 6BE9IK, 6BE9IL, 6BE9IM, 6BE9IN, 6BE9IO, 6BE9IP, 6BE9IQ, 6BE9IR, 6BE9IS, 6BE9IT, 6BE9IU, 6BE9IV, 6BE9IW, 6BE9IX, 6BE9IY, 6BE9IZ, 6BE9JA, 6BE9JB, 6BE9JC, 6BE9JD, 6BE9JE, 6BE9JF, 6BE9JG, 6BE9JH, 6BE9JI, 6BE9JJ, 6BE9JK, 6BE9JL, 6BE9JM, 6BE9JN, 6BE9JO, 6BE9JP, 6BE9JQ, 6BE9JR, 6BE9JS, 6BE9JT, 6BE9JU, 6BE9JV, 6BE9JW, 6BE9JX, 6BE9JY, 6BE9JZ, 6BE9KA, 6BE9KB, 6BE9KC, 6BE9KD, 6BE9KE, 6BE9KF, 6BE9KG, 6BE9KH, 6BE9KI, 6BE9KJ, 6BE9KL, 6BE9KM, 6BE9KN, 6BE9KO, 6BE9KP, 6BE9KQ, 6BE9KR, 6BE9KS, 6BE9KT, 6BE9KU, 6BE9KV, 6BE9KW, 6BE9KX, 6BE9KY, 6BE9KZ, 6BE9LA, 6BE9LB, 6BE9LC, 6BE9LD, 6BE9LE, 6BE9LF, 6BE9LG, 6BE9LH, 6BE9LI, 6BE9LJ, 6BE9LK, 6BE9LL, 6BE9LM, 6BE9LN, 6BE9LO, 6BE9LP, 6BE9LQ, 6BE9LR, 6BE9LS, 6BE9LT, 6BE9LU, 6BE9LV, 6BE9LW, 6BE9LX, 6BE9LY, 6BE9LZ, 6BE9MA, 6BE9MB, 6BE9MC, 6BE9MD, 6BE9ME, 6BE9MF, 6BE9MG, 6BE9MH, 6BE9MI, 6BE9MJ, 6BE9MK, 6BE9ML, 6BE9MM, 6BE9MN, 6BE9MO, 6BE9MP, 6BE9MQ, 6BE9MR, 6BE9MS, 6BE9MT, 6BE9MU, 6BE9MV, 6BE9MW, 6BE9MX, 6BE9MY, 6BE9MZ, 6BE9NA, 6BE9NB, 6BE9NC, 6BE9ND, 6BE9NE, 6BE9NF, 6BE9NG, 6BE9NH, 6BE9NI, 6BE9NJ, 6BE9



# INDEX TO ADVERTISERS

Ace Electronics Associates.....	316	Carr Fastener Company, Div. of	
Ace Engineering & Machine Co., Inc..	36	United-Carr Fastener Corp.....	89
Aeme Wire Co.....	428	CBS-Hytron.....	265
Adams & Westlake Co.....	205	Celco-Constantine Engineering	
Adel Precision Products.....	360	Laboratories Co.....	358
Aeronautical Communications		Century Electronics & Instruments	
Equipment, Inc.....	34	Inc.....	348
Airpax Products Co.....	94	Chicago Standard Transformer Corp.	320
Allegheny Ludlum Steel Corp.....	42	Chicago Telephone Supply Corp.....	39
Allen-Bradley Co.....	132	Christie Electric Corp.....	375
Alpha Metals, Inc.....	370	Cinch Mfg. Corp.....	189
American Electronics, Inc.....	332, 333	Clare & Co., C. P.....	105
American Lava Corporation.....	95	Clarostat Mfg. Co., Inc.....	99
American Machine & Foundry Co.....	311	Cleveland Container Co.....	276
American Rondo.....	358	Cohn Corp., Sigmund.....	367
American Time Products Inc.....	293	Coil Winding Equipment Co.....	380
Amperite Co., Inc.....	355	Computer-Measurements Corp.....	234
Ampex Corp.....	61	Connecticut Hard Rubber Co.....	366
AMP Incorporated.....	197	Consolidated Electroynamics.....	127
Anaconda Wire and Cable Co.....	209	Consolidated Resistance Co. of	
Andrew Corporation.....	115	America.....	387
Arco Steel Corp.....	55	Constantin & Co., L. L.....	269
Arnold Engineering Co.....	13	Continental-Diamond Fibre Div. of the	
Artos Engineering Co.....	268	Budd Company, Inc.....	203
Atlantic Engravers, Inc.....	387	Convair, A Div. of General Dynamics	
Audio Development Co.....	334	Corp.....	27
Augat Bros., Inc.....	364	Coors Porcelain Company.....	125
Automatic Mfg. Div. of General		Cornell-Dubilier Electric Corp.....	271
Instrument Corp.....	301	Cosmic Condenser Co.....	369
Automatic Timing and Controls, Inc..	431	Cossor (Canada) Ltd.....	346
Avnet.....	329	Coto-Coil Co., Inc.....	378
		Cross Co., H.....	376
		Crucible Steel Company of America..	51

Baker & Co., Inc.....	75	Dale Products, Inc.....	249
Ballantine Laboratories, Inc.....	304	Dano Electric Co.....	366
Barry Controls, Inc.....	21	Daven Company.....	3rd Cover
Bausch & Lomb Optical Co.....	318	Daystrom Instrument, Div. of	
Beede Electrical Instrument Co., Inc..	336	Daystrom Inc.....	302
Bell Aircraft Corp.....	116	Daystrom Pacific Corp., A Subsidiary	
Bell Telephone Laboratories.....	213	of Daystrom Inc.....	314
Bendix Aviation Corp.....		De-Jur Amso Corporation.....	23
Red Bank Div.....	66	Delco Radio, Div. of General Motors..	38
Bentley Harris Mfg. Co.....	32	DeMornay-Bonardi.....	365
Berkeley Div., Beckman Instruments		Dialight Corporation.....	425
Inc.....	47, 48, 49	Diamonite Products Mfg. Co.....	230
Bird Electronic Corp.....	359	Dore' Co., John L.....	365
Boonton Radio Corp.....	233	Douglas Aircraft Co., Inc.....	237
Borg Corp., George W.....	340, 341	Dow Chemical Company.....	65
Bourns Laboratories, Inc.....	296	Dow Corning Corp.....	289
Brand & Co., William.....	67	Drakenfeld & Co., Inc., B. F.....	348
Brew, Richard D.....	361	Driver-Harris Company.....	219
Burndy Corporation.....	215	Dumont Laboratories Inc.,	
Burnell & Co., Inc.....	9	Allen B.....	122, 123, 247
Bussmann Mfg. Co.....	33	duPont de Nemours & Co. (Inc.) E. I.	
		Pigments Department.....	128

Caledonia Electronics and		Eagle Signal Corp.....	343
Transformer Corp.....	359	Eastern Industries, Inc.....	37
Cambridge Thermionic Corp.....	72, 73	Edo Corporation, The.....	40
Cannon Electric Co.....	46		
Carborundum Co.....	261		

## PRECISION ENGINEERED

# Sub-Miniature Pilot Lights

... facilitate the solution of miniaturization problems.

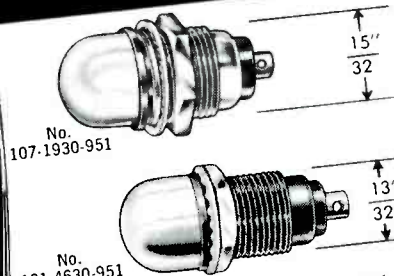

Example: Here are 2 Dialco units with but a tiny difference in o.d. of bushing: A refinement that helps to save space and weight where every fraction counts.



On your next miniaturization project, consult DIALCO for the Pilot Lights. You will quickly find the proper unit for use with either tiny *Incandescent bulbs* (T-1 $\frac{3}{4}$ ); or with *sub-miniature Neon bulbs* (NE-2D).

TWO-TERMINAL units are fully insulated. SINGLE-TERMINAL units are for use on grounded circuits. Also DIMMING or NON-DIMMING sub-miniatures for every requirement. Meet all applicable Military Specifications.

Samples for design purposes on request at once — no charge.

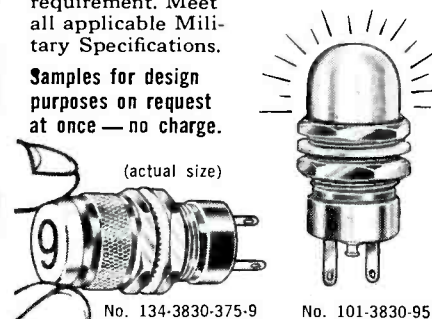

Foremost Manufacturer of Pilot Lights  
**DIALIGHT CORPORATION**

58 STEWART AVE. BROOKLYN 37, N. Y.  
HYacinth 7-7600

Dialight Corp., 58 Stewart Ave., Brooklyn 37, N. Y.

- Send brochures on Sub-Min. Pilot Lights
- Brochures on other Dialco Pilot Lights

Name \_\_\_\_\_  
Position \_\_\_\_\_  
Company \_\_\_\_\_  
Address \_\_\_\_\_

Circle 237 Readers Service Card

# NEW NYLON PARTS from GRC

Economically mass produced on fully automatic patented machines, these stock GRC nylon parts are available in many sizes and types. GRC uses single cavity techniques, molds in one automatic cycle, gets accurate, uniform parts, ready for immediate use.

These advantages, these economies, apply too on parts made to exact specifications . . . in quantities of 50,000 to many millions. Write for bulletin describing GRC's unique methods for injection molding small plastic parts or send prints for quotation. Ask about our zinc alloy die castings, too!

Maximum size:  
1 1/4" long, 0.3 oz.  
No size too small.



NYLON SCREWS



INSULATORS & BUSHINGS



COIL BOBBINS



WASHERS



## GRC NYLON SCREWS MOLDED TO CLOSE TOLERANCES

Economical . . . clean, sharp Class 2 threads . . . high strength to weight ratio . . . built-in electrical insulating properties . . . stable over a wide range of temperatures . . . resilient and elastic, conform to irregular shapes, seal, don't loosen under vibration . . . non-magnetic . . . non-corrosive . . . chemical resistant . . . in colors to order.

These unique GRC nylon screws permit radical product changes . . . improved design. Write, wire, phone TODAY for specification sheets and prices.

Available from stock.



### GRIES REPRODUCER CORP.

World's Foremost Producer of Small Die Castings  
151 Beechwood Avenue, New Rochelle, N. Y. • New Rochelle 2-8600  
Circle 290 Readers Service Card

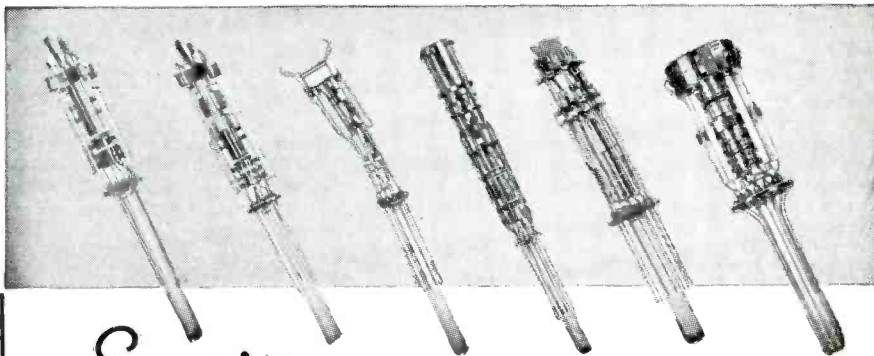

## Superior manufactures superior ELECTRONIC GUN MOUNTS!

For the CRT industry, SUPERIOR offers a full range of magnetic, electrostatic and color gun mounts including mounts for the 110° narrow neck tubes . . . all precision engineered. SUPERIOR makes a complete line of electrostatic focus and deflection guns for radar and industrial purposes including character and Vidicon-type mounts. You may order standard types or we will design and build to your specifications.

Whether your order be large or small, you will enjoy all the benefits of our rigid inspection, testing and control. For complete satisfaction based on dependable service, call or write to

## SUPERIOR ELECTRONICS CORPORATION

208-212 Piaget Ave. • GRegory 2-2500 • Clifton, N. J.

Eisler Engineering Co., Inc.	362
Eitel-McCullough, Inc.	126, 307
Electra Mfg. Co.	254
Electrical Industries	131
Electro Engineering Works, Inc.	374
Electro-Pulse, Inc.	212
Electro Tec Corporation	273
Electronics	295
Electronic Batteries, Inc.	430
Electronic Instrument Co., Inc. (EICO)	382
Electronics Division, Elgin National Watch Co.	354
Electronics Tube Div. of Burroughs Corp.	119
Ellis & Watts Products, Inc.	41
Empire Devices Products Corp.	134
Engineered Electronics Co.	328
Eric Electronics Division, Eric Resistor Corp.	206
Esterline-Angus Co., Inc.	371

Fairchild Controls Corp.	217
Fansteel Metallurgical Corp.	338, 339
Federated Metals Div. of American Smelting & Refining Co.	256
Fenwal, Inc.	68
Fenwal Electronics, Inc.	344
Filtors, Inc.	303
Filtron Co., Inc.	129
Formica Corp.	69
Freed Transformer Co., Inc.	432
Frenchtown Porcelain Co.	370

G-M Laboratories, Inc.	278
Gamewell Company	286
Garrett Corporation	124
General Ceramics Corp.	102
General Controls	368
General Electric Co. Apparatus Dept.	86, 87
Tube Department	323
Semiconductor Products Dept.	100, 101
General Electroynamics Corp.	71
General Mills	306
General Radio Co.	17
Good-All Electric Mfg. Co.	351
Graphic Systems	379
Gries Reproducer Corp.	426
Gudebrod Bros. Silk Co., Inc.	369

Halliburton, Inc.	224
Hallicrafters Company, The	218
Handy & Harmon	118
Hart Manufacturing Co.	308
Harvey Hubbell, Inc.	337
Haydon Mfg. Co., Inc.	292



Heath Company	345
Heiland, a Div. of Minneapolis-Honeywell	96
Helipot Corp., Beckman Div.	222, 223
Hermetic Seal Corporation	35
Hewlett-Packard Company	56, 57, 135
Heyman Mfg. Co.	375
Homelite, a Div. of Textron Inc.	238
Horman Associates, Inc.	387
Hughes Products, a Div. of Hughes Aircraft Co.	85, 227
Hughes Research & Development Laboratories	84
Humphrey, Inc.	262
Hunt Company, Philip A.	208
Hycor Eastern Inc.	70
Hycor Div. of International Resistance Co.	315

Indiana Steel Products Co.	58
Industrial Electronic Engineers	367
Industrial Test Equipment Co.	430
Industrial Timer Corporation	104
Inland Testing Laboratories, a Div. of Cook Electric Co.	64A, 64B, 64C, 64D
Instrument Development Laboratories Inc.	260
Interelectronics	342
International Resistance Co.	108, 109
Iron Fireman Electronics Division	93

J V M Engineering Co.	202
Johnson Company, E. F.	274
Jones Div., Howard B. Cinch Mfg. Co.	379

Kahle Engineering Co.	15
Kato Engineering Co.	428
Kay Electric Co.	29
Kearfott Co., Inc.	326
Kepeco Laboratories, Inc.	193
Kester Solder Co.	241
Kintel (Kay Lab)	76, 77
Kraeuter & Co., Inc.	198
Krueger Instruments, Harold	386

Laboratory for Electronics, Inc.	288
Lampkin Laboratories, Inc.	375
Lapp Insulator Co., Inc.	294
Leach Corporation	347
Leland Inc., G. H.	214
Lenkurt Electric Co.	349

# McCoy quartz crystals

meet  
**5**  
important  
requirements

## SIZE

... Less than 1/2" wide; please note dimensions below.

## WEIGHT

... One twenty-fifth (1/25) of an ounce.

## VIBRATION

... Withstands from 10 to 2000 c.p.s.

## SHOCK

... Withstands from 0 to 30 g.

## STABILITY

... Frequency stabilities of ±.0025% over -55° C to ±90° C possible.

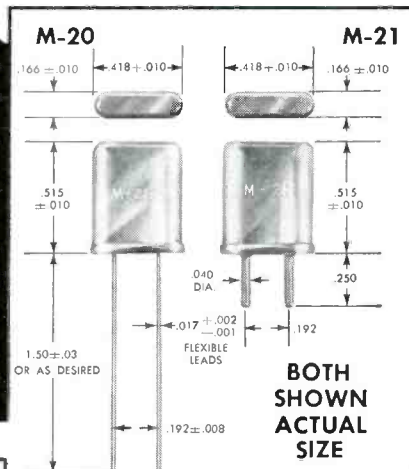

McCoy McMite lightweight quartz crystals extend the limits of electronic design. These little, hermetically sealed units are built rugged to pack regular size performance into minimum space... with no sacrifice of stability or dependability! Produced in frequencies from 3 mc to 125 mc to meet government specifications or made to your own specifications.

SEE US AT THE

"WESCON" Show

SAN FRANCISCO, CALIF.  
AUGUST 20-23, 1957  
BOOTH 2406

FREE ILLUSTRATED CATALOG ON REQUEST  
McCOY ELECTRONICS COMPANY, DEPT. E-8  
MT. HOLLY SPRINGS, PA. — PHONE 376 - 377

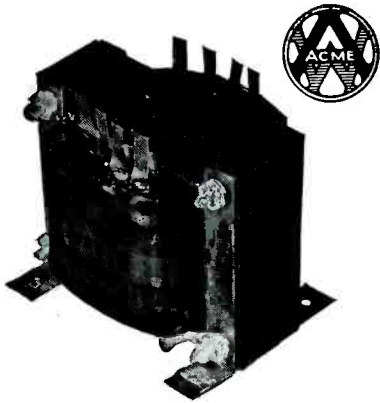

## Standardize On "ACME" UNIFORM COMPONENTS

MAGNET WIRE  
COIL WINDINGS  
VARNISHED INSULATIONS  
INSULATING VARNISHES  
COMPOUNDS

## AND BE SURE OF A BALANCED PRODUCT

For half a century, "Acme" has specialized in trouble-proof insulations. Naturally, a uniform standard of quality has always been an absolute "must" in every "Acme" product.

So, when we say to you: standardize on "Acme" Components in your product, we know you will be uniformly sure of a balanced assembly. You should then have no reject problem, and re-orders from your customers will come to you automatically.

Submit us your products for a no-obligation check-up. Our electrical and electronic engineers may be able to save you many dollars in your production. The "Acme" catalog should be in all your planning. Let us send you one.

**ACME WIRE CO.**  
NEW HAVEN, CONN.

For our complete product line  
see page 611  
Electronics '57 Buyers' Guide

Circle 292 Readers Service Card

Lebel High Frequency Laboratories, Inc. ....	370
Librascope, a Subsidiary of General Precision Equipment .....	133
Linde Company, Div. of Union Carbide Corp. ....	386
Lockheed, Missile Systems Div. Lockheed Aircraft Corp. ....	313

M B Manufacturing Company, A Division of Textron Inc. ....	216
MacDonald, Inc., Samuel K. ....	387
Magnatran, Inc. ....	364
Magnetic Amplifiers, Inc. ....	298
Magnetics, Inc. ....	199, 253
Mallory and Co., Inc., P. R. 114, 136, 191	
Mandrel Industries, Inc. ....	368
Mansel Ceramics Co. ....	377
Marconi Instruments Ltd. ....	5
Marconi Wireless Telegraph Co., Ltd. ....	30, 31
Martin Company ....	255
Maxson Corp., W. L. ....	380
McCoy Electronics Company ....	427
Measurements Corp. ....	369
Metals & Controls Corp., General Plate Div. ....	327
Millen Mfg. Co., Inc., James ....	259
Minneapolis-Honeywell Regulator Co. Davies Laboratories Div. ....	50
Industrial Division ....	130
Model Rectifier Corp. ....	244
Moloney Electric Co. ....	54
Monitor Products Co. ....	376

N J E Corporation ....	121
National Cash Register Co. ....	350
National Lead Company ....	321
Nems-Clarke, Inc. ....	361
New Hermes Engraving Machine Corp. ....	335
Niemand Bros., Inc. ....	362
Norden-Ketay Corp. ....	207
North Electric Co. ....	210
Northeastern Engineering ....	264

Oak Mfg. Co. ....	53
Ohmite Mfg. Co. ....	32A, 32B

Pace Electrical Instruments Co., Inc. ....	363
Pacific Automation Products, Inc. ....	225
Pacific Semiconductors, Inc. ....	243
Packard-Bell ....	291
Page Communications Engineers, Inc. ....	382
Panoramic Radio Products, Inc. ....	353
Perkin Engineering Corp. ....	25
Phalo Plastics Corp. ....	79
Phelps-Dodge Copper Products Corp., Inca Mfg. Div. ....	90, 91

**PRECISE  
CURRENT**  
for your  
**TESTING  
NEEDS!**

**VARIABLE FREQUENCY  
FULLY AUTOMATIC MOTOR  
GENERATOR SETS ADJUST  
360 TO 400 CPS.**

Generator mounted controls include reset buttons, limit switch. Motor and generator remain stationary. Vari-drive pulley adjustment controlled by small motor. Remote control panels available.

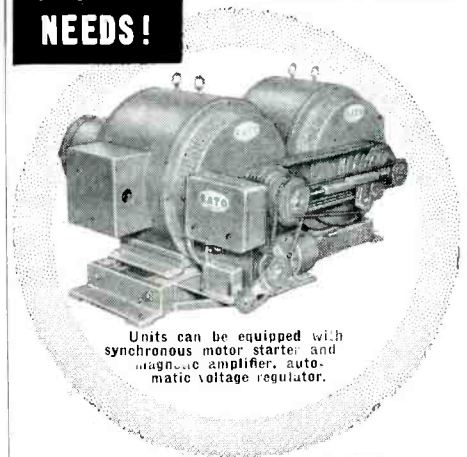

Units can be equipped with synchronous motor starter and magnetic amplifier, automatic voltage regulator.

**MANUAL ADJUSTMENT  
MOTOR GENERATOR SET  
GIVES 45 TO 60 CPS OUTPUT**

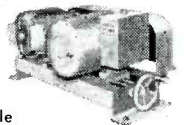

Easily adjusted by simple hand wheel controlling variable pitch pulley V-belt arrangement. Unit holds speed accurately. Frequency meter indicates output. Single phase generator speed varies from 1350 to 1950 rpm.

WRITE FOR NEW FOLDER!  
Builders of Fine Electrical Machinery Since 1928

**KATO Engineering Company**

105 MAXFIELD AVENUE, MANKATO, MINN.  
Circle 294 Readers Service Card

**If Dielectric or Corrosion Problems  
are causing Coil Trouble ...**

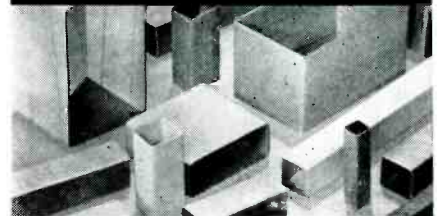

**PRECISION  
can eliminate them!**

Precision specializes in square, rectangular, round or special shaped coil forms ... kraft, fish paper, acetate, DuPont Mylar, Johns-Manville Quinterra, Resinite impregnated or combinations ... to help you solve any dielectric or corrosion problem.

Precision Paper Tubes can be made to your exact specifications in all sizes from 1/16" square to 8" square with wall thicknesses of from .010 to .125 ... in standard or patented DI-FORMED construction for greater crush resistance, tensile strength and dimensional stability.

• Write, wire or phone  
for full information

**PRECISION PAPER TUBE CO.**

2041 W. CHARLESTON ST. • CHICAGO 47, ILL.  
Plant No. 2: 1 Flower Street, Hartford, Conn.

Circle 293 Readers Service Card

August 1, 1957 — ELECTRONICS



Philamon Laboratories, Inc.	229
Philbrick Researches, Inc., George A.	310
Philco Corporation	257
Phillips Control Corp.	372
Photocircuits Corporation	252
Photographic Products, Inc.	218
Plastoid Corporation	300
Polarad Electronics Corporation	59
Potter & Brumfield, Inc.	250, 251
Potter Instrument Co., Inc.	429
Precision Capacitors, Inc.	380
Precision Paper Tube Co.	428
Pulse Engineering	226
Pyramid Electric Co.	319

RBM Division Essex Wire Corp.	64
R C A Electron Tube Division	4th Cover
Radiation Inc.	312
Radio Cores, Inc.	236
Radio Engineering Laboratories, Inc.	221
Radio Engineering Products	336
Radio Materials Corp.	235
Raybestos-Manhattan, Inc.	74
Raytheon Mfg. Company	18, 19, 277
Reeves Instrument Corp.	97
Relay Sales, Inc.	231
Resistance Products Co.	110
Rex Rheostat Co.	387

Sangamo Electric Co.	106
Sarkes Tarzian, Inc.	322
Seallectro Corp.	204
Sel-Rex Corporation	360
Shielding Inc.	211
Sierra Electronic Corp.	201
Sigma Instruments Inc.	290
Sola Electric Co.	309
Somers Brass Company, Inc.	386
Sorensen & Co., Inc.	4
South Chester Corporation	120
Southern Electronics Corp.	239
Spectrol Electronics, Div. of Carrier Corporation	299
Sperry Gyroscope Company, Division of Sperry Rand Corp.	107, 245
Sprague Electric Co.	11
Stackpole Carbon Co.	117
Stevens Arnold, Inc.	363
Stoddart Aircraft Radio Co., Inc.	373
Stromberg-Carlson Company	317, 366
Stupakoff Div. of Carborundum Co.	258
Superior Electric Company	263
Superior Electronics Corp.	426
Superior Tube Co.	78
Sylvania Electric Products, Inc.	62, 63, 325, 96A, 96B, 96C, 96D
Syntronic Instruments, Inc.	372

Taylor Fibre Co.	60
Technitrol Engineering Co.	324
Technology Instrument Corp.	228
Tektronix, Inc.	305
Telechrome, Inc.	43
Telrex Laboratories	371
Texas Instruments Incorporated	128A, 128B, 128C, 128D, 195

# Potter

## Model 905 Digital Magnetic Tape Handler

*(75 inches per second with 3 msec starts and stops)*

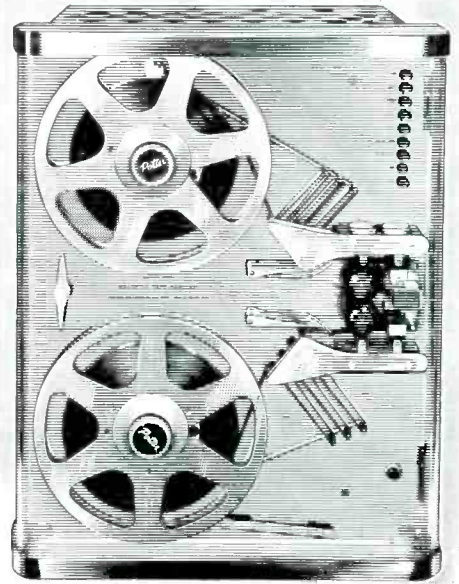

**Meets all requirements for speed and convenience in processing large quantities of digital data**

The Potter Model 905 is the result of the most extensive study of data-processing requirements. It combines high speed with complete reliability and easy accessibility to all wiring and parts. The Potter machined bronze head with precisely aligned gaps provides dimensional stability and minimizes digital drop-outs caused by oxide pickup.

**Tape widths:**

- A - ¼" (2 or 3 channels)
- B - ½" (6 or 7 channels)
- C - ¾" (up to 8 channels)
- D - ¾" (up to 10 channels)
- E - 1" (up to 13 channels)
- F - 1¼" (up to 15 channels)

**Speed combinations:**

- J - 30 and 7.5 inches per second
- K - 60 and 15 inches per second
- L - 75 and 18.75 inches per second
- X - Special (speeds up to 75 inches per second in ratios of 2 to 1, 3 to 1 and 6 to 1 are available on special order. Other speed combinations can be accommodated.)

**Start time:** 3 milliseconds  
**Stop time:** 3 milliseconds  
**Reel sizes:** 8" or 10½" standard NAB reels. Adaptors for other types can be provided.

**Control:** Front panel pushbuttons or remote control contact closure and pulses.

**Weight:** 100 pounds  
**Dimensions:** Panel, width . . . 19"; height . . . 24½"  
 Depth behind panel . . . 13½"  
 Depth in front of panel . . . 3½"

**Power Requirements:** 110 to 120 volts, 60 cps, 400 watts.

For more information, write, wire or phone your Potter representative or the factory.



**POTTER INSTRUMENT COMPANY, INC.**

115 Cutter Mill Road

Great Neck, L. I., N. Y.

WESCON BOOTH 1003; ISA BOOTH 1266





EQUIPMENT  
(Used or Surplus New)  
For Sale .....415-424

WANTED  
Equipment ..... 415

EMPLOYMENT OPPORTUNITIES  
ADVERTISERS

Abbott's Employment Specialists.....	400, 411
AC Electronics Div., General Motors Corp. ....	392, 394, 402, 410
Admiral Corp. ....	406
Aircraft Radio Corp.....	414
Applied Science Corp. of Princeton.....	398
Arma, Div. of American Bosch Arma Corp.	390
Bendix Aviation Corp. Pacific Division .....	396
Products Division—Missiles .....	394
Systems Division .....	408
York Division .....	398
Burroughs Corp., Research Center.....	400
Cadillac Associates Inc.....	410
Chatham Electronics (Div. Tung-Sol Electric) .....	404
Clevite Research Center.....	404
Cooper, J. J.....	410
Continental Can Co.....	413
Fidelity Personnel Service.....	410
Gates Radio Co.....	415
General Electric Co. Philadelphia, Pa. ....	395
Syracuse, N. Y.....	405, 413

AN OPPORTUNITY AND A CHALLENGE  
FOR COMPONENT AND SYSTEMS DESIGNERS

# SIMPLIFY AND INCREASE SYSTEM RELIABILITY

## BY DESIGNING TO CHARACTERISTICS OF LOW IMPEDANCE A-C DIFFERENTIAL TRANSFORMERS

*infinite resolution • no sliding contact nor bearings  
frictionless • unlimited life, nothing to wear out  
temperature stable • high signal to noise ratio  
small, compact, lightweight*

Recommended for hydraulic servo valve feedback, rate gyros, accelerometers, hydraulic servo motors, pressure, flow, position and level detectors, Atcotran Differential Transformers are setting the pace for improved reliability of components in existing systems by replacement of sliding contact pickups.

New systems designs incorporating the full advantage of inherent characteristics of these transducers promise outstanding benefits:

- 1) The low impedance characteristics of differential transformers can reduce or eliminate the need for filter circuits.
- 2) Ratio winding techniques and simple interconnection for algebraic functions frequently can be accomplished without intermediate components.
- 3) The reliability and precision of differential transformers makes possible a new order of performance.

### EXPERIMENTAL KIT



To enable designers to familiarize themselves with the application of differential transformers in the laboratory, the Atcotran Differential Transformer Experimental Kit has been made available. It contains seven standard coils of various characteristics, a flexure plate and clamp, a demodulator and a 32-page HANDBOOK containing theory and application data on differential transformers.

A \$324.00 value specially priced at only \$189.50 for lab investigation.

Start exploring this new opportunity now. Order your kit today.

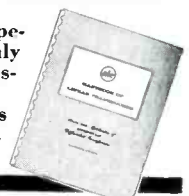



**THE WORLD'S LEADING  
DESIGNERS AND MANUFACTURERS  
OF LOW IMPEDANCE  
DIFFERENTIAL TRANSFORMERS**

**AUTOMATIC TIMING & CONTROLS, INC.**  
formerly Automatic Temperature Control Co., Inc.  
Subsidiary of Safety Industries, Inc.  
KING OF PRUSSIA 12, PA.

Please send me an Atcotran Differential Transformer Experimental Kit and invoice \$189.50 against our purchase order No. \_\_\_\_\_

NAME \_\_\_\_\_  
COMPANY \_\_\_\_\_  
ADDRESS \_\_\_\_\_  
CITY \_\_\_\_\_ STATE \_\_\_\_\_

FOREIGN SALES: ATC EXPORT DEPARTMENT, 1505 RACE ST., PHILA. 2, PA.

# FREED

**MIL-T-27A POWER AND FILAMENT TRANSFORMERS AND HERMETICALLY SEALED FILTER REACTORS**

**For Immediate Delivery From Stock**

## POWER TRANSFORMERS-STANDARD

All primaries 105/115/125 v., 60 c.p.s.

Cat. No.	Hi Volt Sec.	ct	DC Volts	DC Amps	Filament #1		Filament #2		MIL Case Size
					Volt	Amp.	Volt	Amp.	
MGP1	400/200	✓	185	.070	6.3/5	2	6.3	3	HA
MGP2	650	✓	260	.070	6.3/5	2	6.3	4	JB
MGP3	650	✓	245	.150	6.3	5	5.0	3	KB
MGP4	800	✓	318	.175	5.0	3	6.3	8	LB
MGP5	900	✓	345	.250	5.0	3	6.3	8	MB
MGP6	700	✓	255	.250					KB
MGP7	1100	✓	419	.250					LB
MGP8	1600	✓	640	.250					NB

## FILAMENT TRANSFORMERS-STANDARD

All primaries 105/115/125 v., 60 c.p.s.

Cat. No.	Secondary		Test VRMS	MIL Case
	Volt	Amp		
MGF1	2.5	3.0	2,500	EB
MGF2	2.5	10.0	2,500	GB
MGF3	5.0	3.0	2,500	FB
MGF4	5.0	10.0	2,500	HB
MGF5	6.3	2.0	2,500	FB
MGF6	6.3	5.0	2,500	GB
MGF7	6.3	10.0	2,500	JB
MGF8	6.3	20.0	2,500	KB
MGF9	2.5	10.0	10,000	JB
MGF10	5.0	10.0	10,000	KB

## HERMETICALLY SEALED FILTER REACTORS

Meet MIL-T-27A Specifications

Catalog No.	Inductance Henry	Rat. Current DC Ma.	DC Res. Ohms	Test Volt Kilovolts	Case No.
MGC 1	100	10	3,500	1.	AJ
MGC 2	4	50	230	1.	AJ
MGC 3	10	50	325	1.	EB
MGC 4	20	50	475	1.5	FA
MGC 5	30	50	650	1.5	FA
MGC 6	3	75	175	1.	AJ
MGC 7	6	75	235	1.5	EB
MGC 8	12	75	265	1.5	FA
MGC 9	3.5	100	145	1.	EB
MGC 10	8	100	180	1.5	FA
MGC 11	12	100	190	2.	GA
MGC 12	2	150	92	1.5	EB
MGC 13	4	150	115	1.5	FA
MGC 14	8	150	125	2.	GA
MGC 15	11	150	120	2.5	JB
MGC 16	2.5	200	70	1.5	FA
MGC 17	4	200	80	2.	GA
MGC 18	7	200	135	2.	HB
MGC 19	10	200	125	2.5	JA
MGC 20	2.5	300	50	2.	GA
MGC 21*	4	300	62	2.5	HB
MGC 22	6	300	85	2.5	JB
MGC 23*	8	300	65	2.5	KB
MGC 24	10	300	100	2.5	LA
MGC 25*	2	400	37	2.5	HB
MGC 26	6	400	60	2.5	KB
MGC 27*	2	500	35	2.5	JA
MGC 28	4	500	45	2.5	KB
MGC 29*	7	500	50	2.5	MB
MGC 30*	2	700	20	2.5	LB
MGC 31*	1.75	1,000	12.5	2.5	MB

\*Not stocked, available on short delivery.

Send for NEW 48 page transformer catalog. Also ask for complete laboratory test instrument catalog.

**FREED TRANSFORMER CO., INC.**

1722 Weirfield St., Brooklyn (Ridgewood) 27, N.Y.

Circle 299 Readers Service Card

General Precision Laboratory Inc.....	398	Barry Electronics Corp.....	415, 423
Goodyear Aircraft Corp. Akron, Ohio .....	399	Blan .....	422
Litchfield Park, Arizona.....	394		
International Business Machines Corp.....	393	C & B Electronics.....	422
Johns Hopkins University, The Applied Physics Laboratory.....	392	C & H Sales Co.....	419
Operations Research Office.....	409	Calvert Electronics Inc.....	418
Kollsman Instrument Corp.....	415	Candee Co., J. J.....	420, 422
		Communications Equipment Co.....	417
		Conrad, M. ....	420, 423
Marine Laboratory, The.....	404	Dayton Air Force Depot.....	417
Melpar, Inc. ....	390	Engineering Associates .....	421
Minneapolis Honeywell Regulator Co. Brown Instruments Division.....	401	Motorola Inc. Chicago, Illinois .....	396
Monarch Personnel .....	410	Phoenix, Arizona .....	411
Motorola Inc. Chicago, Illinois .....	396	Fineberg, J. N.....	422
Phoenix, Arizona .....	411	Finnegan, H. ....	415
National Co., The.....	407	Hassett Storage Warehouses.....	422
Otis Elevator Co.....	414	Instrument Service Corp.....	421
Raytheon Manufacturing Co.....	388, 389	JSH Sales Co.....	416
RCA Service Co., Inc.....	409	Republic Aviation Corp.....	404
Republic Aviation Corp.....	404	Sanders Associates, Inc.....	412
Scientists, Engineers & Executives, Inc....	410	Scientists, Engineers & Executives, Inc....	410
Stavid Engineering Inc.....	412	Stavid Engineering Inc.....	412
Stromberg-Carlson Co. ....	403	Stromberg-Carlson Co. ....	403
Sylvania Electric Products Inc.....	402	Sylvania Electric Products Inc.....	402
Texas Instruments Inc.....	391	Texas Instruments Inc.....	391
		Pacific International University.....	415
		Radalab Inc. ....	420
		Raway Bearing Co.....	422
		Seg Electronics Co., Inc.....	422
		"TAB" .....	424
		Universal Relay Corp. (formerly Universal General Corp.)....	420
		Western Engineers .....	421
		Wilgreen Industries .....	423

## SEARCHLIGHT SECTION ADVERTISERS INDEX

Alltronics-Howard Co. ....	422
Arrow Sales Inc.....	420

This index is published as a service. Every care is taken to make it accurate, but ELECTRONICS assumes no responsibility for errors or omissions.



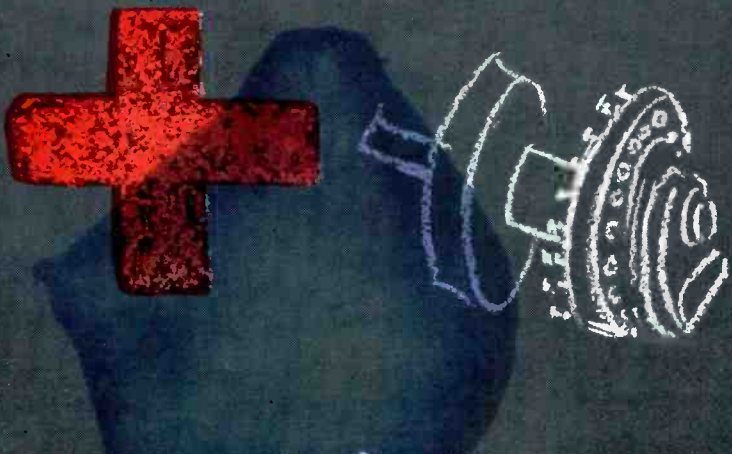
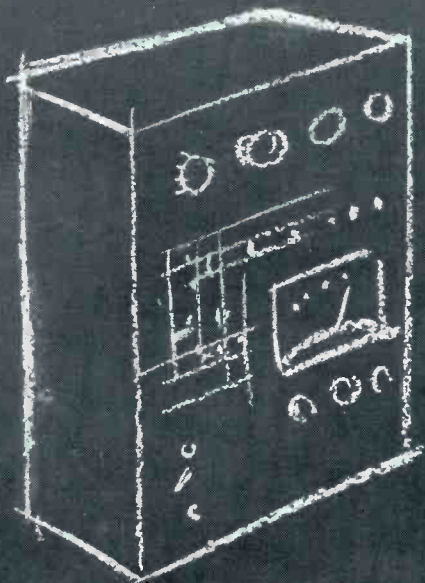

dependability, precise operation and unwavering performance



an engineering formula made famous by

# DAVEN PRECISION ROTARY STEP-TYPE SWITCHES

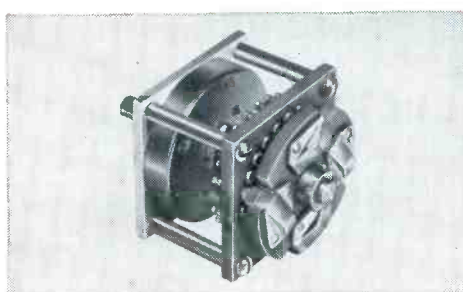

This has been established as an engineering principle: for dependable, fool-proof switching in complex control equipment and instruments, more and more engineers are specifying DAVEN Precision Rotary Step-Type Switches.

DAVEN switches, with their knee-action rotor and precious metal contacts, are

constructed to withstand continuous use over long periods of time under severest operating conditions.

Solutions to practically all rotary switch requirements . . . your requirements . . . can be found within the thousands of combinations of poles, positions and decks available in DAVEN'S complete line. When you specify a DAVEN rotary switch, you are specifying the finest.

ONLY DAVEN OFFERS THESE FEATURES:

- **Patented knee-action rotor**—assures low and uniform contact resistance and provides tamper-proof, trouble-free operation over the life of the switch.
- **One-piece combination contact and turret-type solder lug**—solid-silver alloy contacts, gold plated to resist corrosion. Turret design provides excellent electrical and mechanical connections.

• **Roller-type detent** gives positive indexing action.

• As many as **eight poles** available on each deck — important where minimum space is a factor.

Write for complete data, catalog and engineering information.

Today, more than ever,  
the DAVEN   
stands for dependability!

THE **DAVEN** CO.

LIVINGSTON, NEW JERSEY



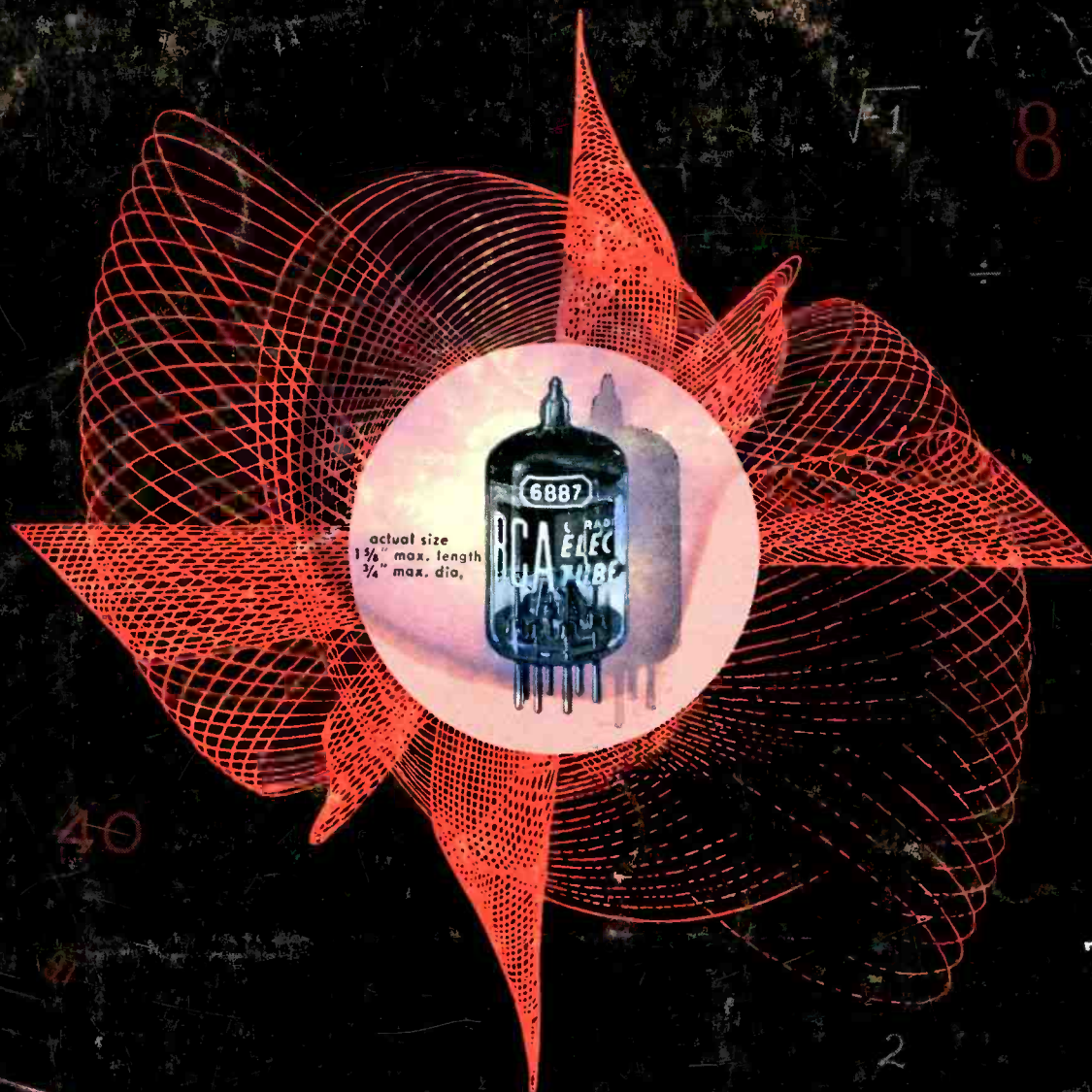

# FIRST TWIN DIODE...

Designed especially for computers

## RCA-6887 Cuts Heater Power

 Combining exceptional dependability, small size, and a low-wattage heater (1.26 watts)... the new RCA-6887 performs with high efficiency on *one third less heater power* than conventional twin diodes. This new tube offers up-to-date advantages for compact, medium-speed switching circuits.

Among the many design features of the RCA-6887 contributing to long life and high dependability are a pure-tungsten heater, special-alloy cathodes which retard interface, high-purity nickel plates, plus a protective shield to minimize interelectrode leakage. Each cathode utilizes a separate base pin to permit flexibility of circuit arrangement.

Strict production controls based on typical electronic computer conditions, extreme care in selection and inspection of materials, and rigorous tests for shorts and leakage—assure uniformity of electrical characteristics and stability initially and throughout life.

Investigate the many advantages RCA-6887 offers your medium-speed electronic computer designs. Contact your RCA Field Representative at the RCA District Office nearest you

- EAST:** Humboldt 5-3900  
744 Broad Street  
Newark 2, N. J.
- MIDWEST:** Whitehall 4-2900  
Suite 1181  
Merchandise Mart Plaza  
Chicago 54, Ill.
- WEST:** Raymond 3-8361  
6365 East Washington Blvd.  
Los Angeles 22, Calif.

 **RADIO CORPORATION OF AMERICA**  
Tube Division Harrison, N. J.

For technical data on RCA-6887, write RCA Commercial Engineering, Section H-19-Q-1, Harrison, N. J.